

FLOOREQUIPMENTPARTS.COM



3110/3120

Commercial Upright Vacuum Cleaner
Aspirateur Commercial
Aspirador Comercial

Part No.:

Single Motor Upright Vacuum Cleaner

614215 - 3110 12" 120V/60Hz

614216 - 3110 15" 120V/60Hz

Dual Motor Upright Vacuum Cleaner

614306 - 3120 12" 120V/60Hz

614217 - 3120 15" 120V/60Hz

614218 - 3120 18" 120V/60Hz

**Operator Manual
and Parts List**

**Opérateur Manuel
et Liste Des Pièces**

**Manual De Operador
Y Lista De Repuestos**



614264
Rev. 03 (06-05)

BAG HOUSING GROUP

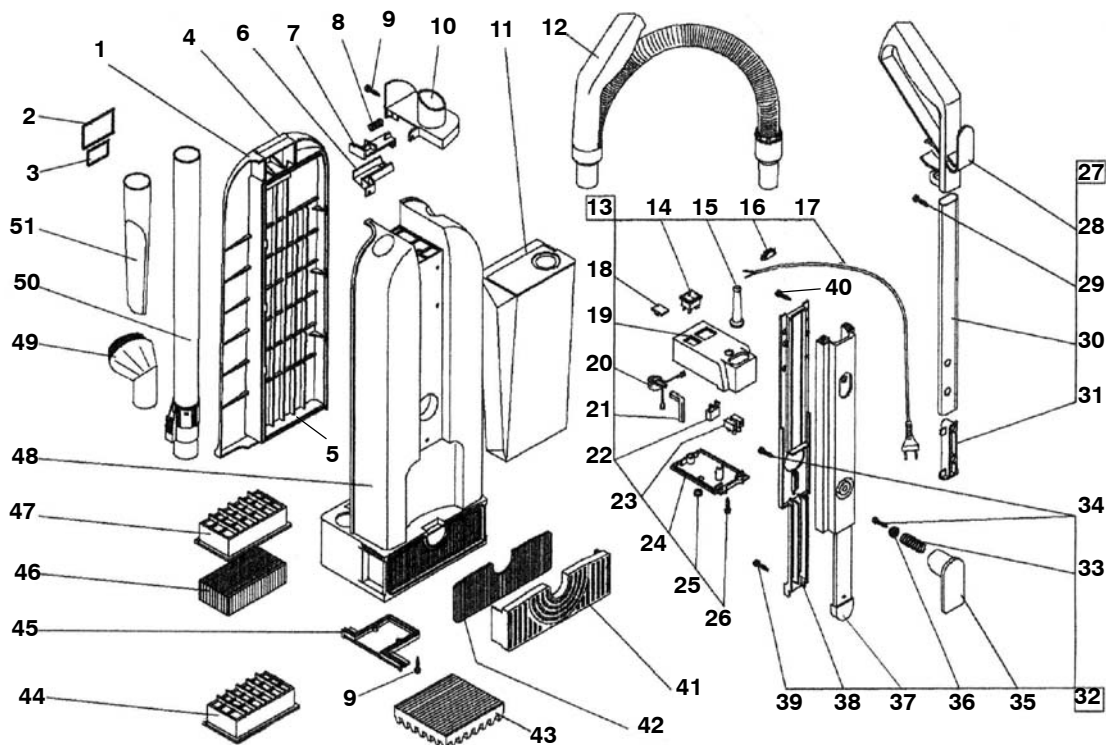

REF	PART #	DESCRIPTION	QTY.
∇	1	1015713 COVER ASM., TEAL HSG W/LBLS	1
		1025310 COVER ASM., BLK HSG W/LBLS	1
▲	2	613280 LABEL, WARNING	1
▲	3	1015715 LABEL, FILTER IMPORTANT	1
▲	4	1022847 LATCH, CVR, BAG HSNG, W/SPRNG	1
▲	5	1015716 ●GASKET, COVER, BAG HOUSING	1
	6	1015620 GUIDE, BUTTON	1
	7	1015621 BUTTON, HOLDER, BAG	1
	8	1015619 SPRING, BUTTON, BAG HOLDER	1
	9	1015719 SCREW KIT, 3.9X16, KIT=20 PCS	1
	10	1015618 ADAPTOR, BAG	1
	11	1014505 ●BAG, FLTR PCK= 8 BAGS/ 2 FLTR	1
	12	1015651 ●HOSE EXT., W/HANDLE GRIP	1
∇	13	1015600 HOUSING ASM., SWITCH	1
▲	14	1015617 ●SWITCH, MAIN, 15A	1
▲	15	1015607 STRAINRELIEF	1
▲	16	1015646 CLAMP, CORD	1
▲	17	1015647 ●CORD, POWER 17/3X15M, YEL	1
▲	18	1015616 LENS, RED, BAG FULL	1
▲	19	1015603 HOUSING, SWITCH	1
▲	20	1015615 ●SENSOR, VACUUM, W/LIGHT	1
▲	21	1015606 TUBE, SENSOR	1
▲	22	1015672 FILTER, ELECTRICAL, RFI	1
▲	23	130005 TERMINAL, BLOCK, 3 POLE	1
▲	24	1015708 COVER, HOUSING, SWITCH	1
▲	25	1015707 SEAL, ORG	1
▲	26	1015727 SCREW KIT, 3.9X32, KIT=20 PCS	1

REF	PART #	DESCRIPTION	QTY.
∇	27	1015711 HANDLE ASM.	1
▲	28	1015648 HANDLE	1
▲	29	1015726 SCREW KIT, 3.9X13, KIT=20 PCS	1
▲	30	1015649 TUBE, HANDLE, W/BUTTONS	1
▲	31	1015650 BUTTON ASM., HANDLE	1
∇	32	1015710 PANEL ASM., FRONT, ELECTRICAL	1
▲	33	1015596 SPRING	1
▲	34	1015718 SCREW KIT, 3.5X16, KIT=20 PCS	1
▲	35	1015605 HOOK CORD, LOWER	1
▲	36	1015604 CLIP, SPRING, RING	1
▲	37	1015613 HANDLE ASM., FRAME	1
▲	38	1015614 COVER, HANDLE	1
▲	39	1015724 SCREW KIT, 3.9X9.5, KIT=20 PCS	1
▲	40	1015721 SCREW KIT, 3.5X16, KIT=20 PCS	1
	41	1015608 GRILL, FILTER	1
	42	1015609 ●FILTER KIT, EXHAUST, KIT=10	1
	43	1015611 FILTER, FOAM	1
	44	1016503 FILTER, H.E.P.A. (OPTIONAL)	1
	45	1015622 CONVEYOR	1
	46	1015610 ●FILTER, MOTOR, PROTECTION	1
	47	1015668 HOUSING, FILTER	1
	48	1015598 HOUSING BAG, TEAL	1
		1025308 HOUSING, BAG, BLACK	1
	49	1015655 BRUSH, DUSTING	1
	50	1015652 ●WAND EXT., TELESCOPIC	1
	51	1015654 TOOL, CREVICE	1

∇ ASSEMBLY / ENSEMBLE / CONJUNTO ● RECOMMENDED STOCK ITEM / ÉLÉMENTS DE STOCK RECOMMANDÉS / PIEZAS RECOMENDADAS EN ALMACÉN
 ▲ INCLUDED IN ASSEMBLY / Y COMPRIS EN ENSEMBLE / INCLUIDO A CONJUNTA

SINGLE MOTOR BASE GROUP

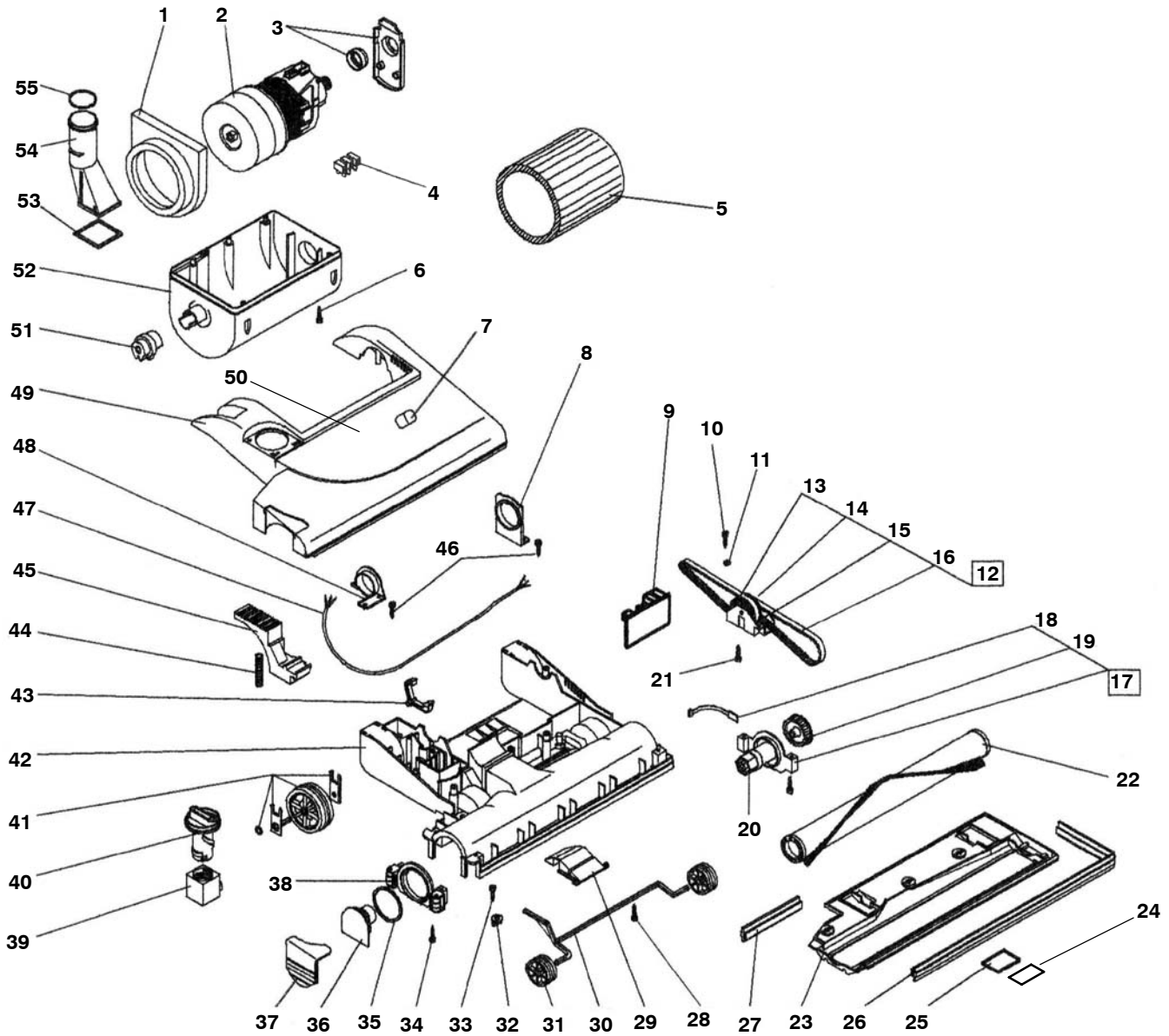

SINGLE MOTOR BASE GROUP

REF	PART #	DESCRIPTION	QTY.	
1	1015658	GASKET, MOTOR	1	
2	1015657	●MOTOR, VAC, W/PULLEY	1	
3	1015659	GASKET, MOTOR, BRH HOLDER	1	
4	1015645	TERMINAL BLOCK, 5 POLE	1	
5	1015612	FILTER, MOTOR	1	
6	1015727	SCREW KIT, 3.9X32, KIT=20 PCS	1	
7	1015602	LENS KIT, RED/GREEN, KIT=2 PCS	1	
8	1015671	SUPPORT, LEFT	1	
9	1026063	●CIRCUITBOARD, SMU	1	
10	1015718	SCREW KIT, 3.5X16, KIT=20 PCS	1	
11	1015717	WASHER KIT, 3.5, KIT=20 PCS	1	
▽	12	1015681	●TRANS ASM., BELTS, PULLEYS	1
▲	13	1015660	PULLEY ASM., DBL W/BEARINGS	1
▲	14	1015706	PIN 5X28	1
▲	15	1015661	SUPPORT PULLEY	1
▲	16	1015662	●BELT, TIMING, 276 6MM, SMU	2
▽	17	1015709	●SUPPORT ASM., BRUSH W/PULLEY & SENSOR	1
▲	18	N/A	SPEED SENSOR	1
▲	19	1015682	PULLEY, BSH, W/METAL INSERT	1
20	1015728	CLUTCH KIT, DRIVE	1	
21	1015735	SCREW KIT, 3.9X1.3 TG, KIT=20 PCS	1	
22	1015729	●BRUSH, 12" MODEL, ROLLER	1	
	1015730	●BRUSH, 15" MODEL, ROLLER	1	
▽	23	1015700	SHOE, 12" MODEL, SMU W/LBLS	1
	1016388	SHOE, 15" MODEL, SMU W/LBLS	1	
▲	24	1016350	LABEL, SHOE, IMPORTANT	1
▲	25	1016348	LABEL, SHOE, WARNING	1
26	1015703	BUMPER, 12" MODEL, FRONT	1	
	1015704	BUMPER, 15" MODEL, FRONT	1	
27	1015702	BUMPER, 15" MODEL, BACK	1	
28	1015723	SCREW KIT, 4.8X13 TG, KIT=20 PCS	1	

REF	PART #	DESCRIPTION	QTY.	
29	1016387	COVER, CHANNEL SMU	1	
30	1015757	AXLE, FRONT	1	
31	1015697	WHEEL, FRONT	2	
32	1015696	CLIP KIT, COVER, KIT=20 PCS	1	
33	1015720	SCREW KIT, 3.5X9.5 TG, KIT=20 PCS	1	
34	1015722	SCREW KIT, 3.9X25, KIT=20 PCS	1	
35	1015694	SEAL, O-RING	1	
36	1015693	SUPPORT, BRUSH	1	
37	1015737	COVER, SIDE	1	
38	1015695	SUPPORT ASM., SIDE W/WHEELS	1	
39	1015691	BLOCK, BRUSH, ADJUSTER	1	
40	1015690	KNOB, ADJUSTING	1	
41	1015683	●WHEEL ASM., REAR	2	
42	1015687	BASE, SINGLE MTR, 12" MODEL	1	
	1015644	BASE, SINGLE MTR, 15" MODEL	1	
43	1015686	LEVER, LIFT, BASE	1	
▽	614404	PEDAL KIT, W/SPRG 12-15" MODEL	1	
▲	44	1015685	SPRING, PEDAL 12"-15" MODEL	1
▲	45	1015684	PEDAL, FOOT	1
46	1015725	SCREW KIT, 3.9X19, KIT=20 PCS	1	
47	1015680	CORD, BASE	1	
48	1015670	SUPPORT, RIGHT	1	
49	1015675	COVER, 12", TEAL, W/LENS & LBL	1	
	1025305	COVER, 12", BLK, W/LENS & LBL	1	
	1016386	COVER, 15", TEAL, W/LENS & LBL	1	
50	614273	LABEL, TENNANT 3110	1	
51	1015669	PIVOT, LATCH	1	
52	1015666	HOUSING, MOTOR	1	
53	1015667	GASKET, CONVEYOR	1	
54	1015664	TUBE, CONVEYOR	1	
55	1015663	SEAL, O-RING	1	

● RECOMMENDED STOCK ITEM / ÉLÉMENTS DE STOCK RECOMMANDÉS / PIEZAS RECOMENDADAS EN ALMACÉN

▽ ASSEMBLY / ENSEMBLE / CONJUNTO
 ▲ INCLUDED IN ASSEMBLY / Y COMPRIS EN ENSEMBLE / INCLUIDO A CONJUNTA

SINGLE MOTOR ELECTRICAL DIAGRAM (120V)

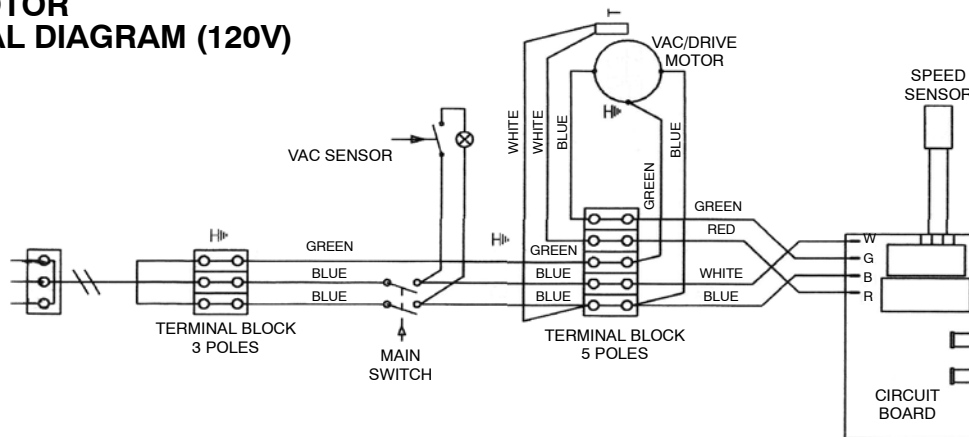

DUAL MOTOR BASE GROUP

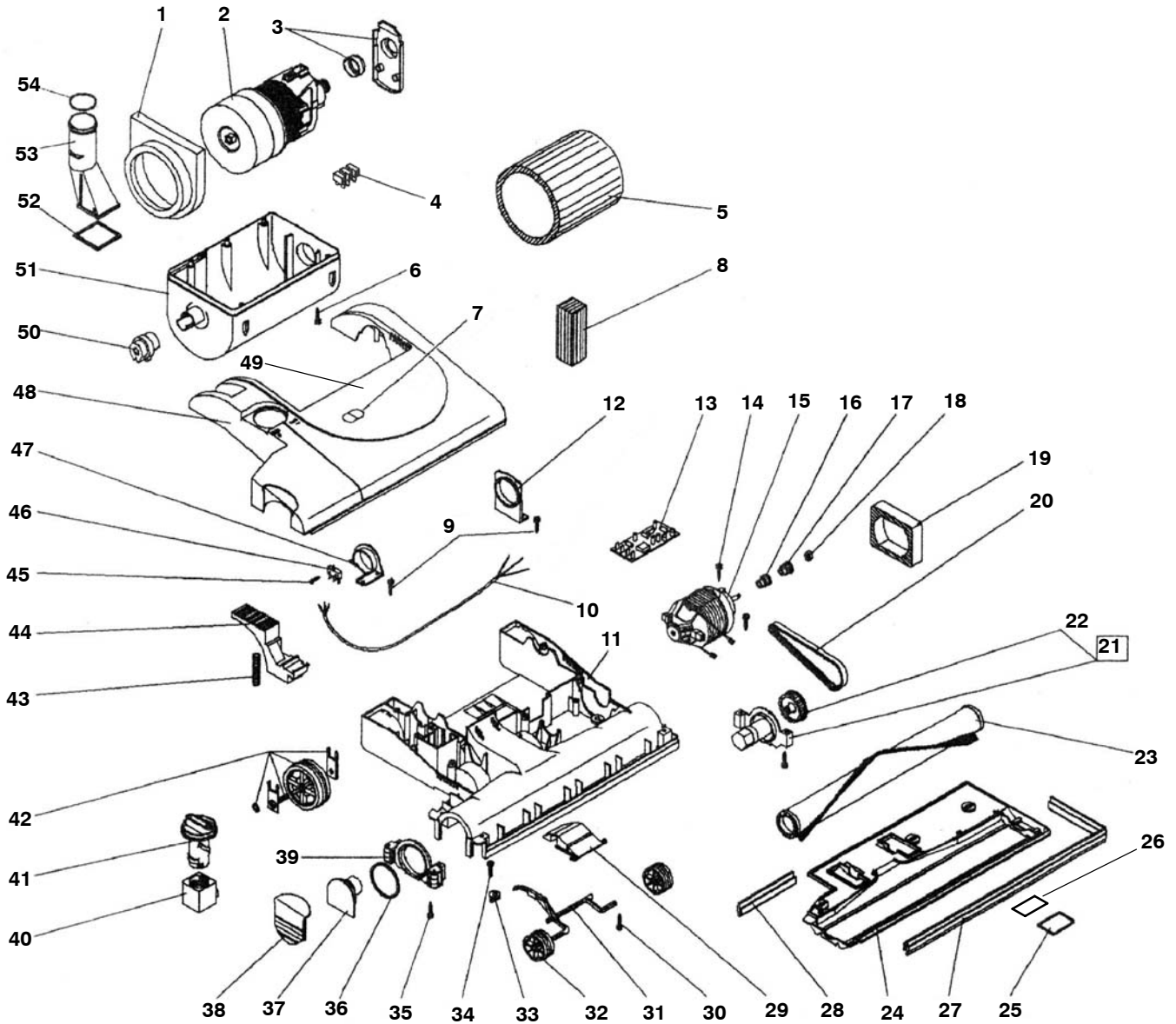

DUAL MOTOR BASE GROUP

REF	PART #	DESCRIPTION	QTY.
1	1015658	GASKET, MOTOR	1
2	1015740	●MOTOR, VAC, W/BAL DISC	1
3	1015659	GASKET, MOTOR, BRH HOLDER	1
4	130005	TERMINAL BLOCK, 3 POLE	1
5	1015612	FILTER, MOTOR	1
6	1015727	SCREW KIT, 3.9X32, KIT=20 PCS	1
7	1015601	LENS KIT, RED/GREEN, KIT=2 PCS	1
8	1015747	FILTER	1
9	1015725	SCREW KIT, 3.9X19, KIT=20 PCS	1
10	1015746	CORD, BASE	1
11	1016509	BASE, DUAL MTR, 12" MODEL	1
	1015688	BASE, DUAL MTR, 15" MODEL	1
	1015749	BASE, DUAL MTR, 18" MODEL	1
12	1015671	SUPPORT, LEFT	1
13	1015739	●CIRCUITBOARD, DUAL MOTOR	1
14	1015725	SCREW KIT, 3.9X19, KIT=20 PCS	1
15	1015755	MOTOR, 12"/15" MDL, BRUSH 120V	1
	1015756	MOTOR, 18" MODEL, BRUSH 120V	1
16	1015741	SPACER	1
17	1015742	PINION	1
18	42368	NUT, M4	1
19	1015753	FILTER, MOTOR	1
20	1015743	●BELT, TIMING, 249 M7, DUAL MTR	1
▽	1015754	SUPPORT ASM., BRSH W/PULLEY	1
▲	1015682	PULLEY, BSH, W/METAL INSERT	1
23	1015729	●BRUSH, 12" MODEL, ROLLER	1
	1015730	●BRUSH, 15" MODEL, ROLLER	1
	1015748	●BRUSH, 18" MODEL, ROLLER	1
▽	1016511	SHOE, 12" MODEL, DL MTR W/LAB	1
	1015701	SHOE, 15" MODEL, DL MTR W/LAB	1
	1015750	SHOE, 18" MODEL, DL MTR W/LAB	1
▲	1016350	LABEL, SHOE, IMPORTANT	1
▲	1016348	LABEL, SHOE, WARNING	1
27	1015703	BUMPER, 12" MODEL, FRONT	1
	1015704	BUMPER, 15" MODEL, FRONT	1

REF	PART #	DESCRIPTION	QTY.	
27	1015752	BUMPER, 18" MODEL, FRONT	1	
28	1015702	BUMPER, 15" MODEL, BLACK	1	
	1015751	BUMPER, 18" MODEL, BLACK	1	
29	1015699	COVER, CHANNEL	1	
30	1015723	SCREW KIT, 4.8X13 TG, KIT=20 PCS	1	
31	1015698	AXLE, FRONT	1	
32	1015697	WHEEL, FRONT	2	
33	1015696	CLIP KIT, COVER, KIT=20 PCS	1	
34	1015720	SCREW KIT, 3.5X9.5 TG, KIT=20 PCS	1	
35	1015722	SCREW KIT, 3.9X25, KIT=20 PCS	1	
36	1015694	SEAL, O-RING	1	
37	1015693	SUPPORT, BRUSH	1	
38	1015692	COVER, SIDE	1	
39	1015695	SUPPORT ASM., SIDE W/WHEELS	1	
40	1015691	BLOCK, BRUSH, ADJUSTER	1	
41	1015690	KNOB, ADJUSTING	1	
42	1015689	●WHEEL ASM., REAR	2	
▽	614404	PEDAL KIT, W/SPRG 12-15" MODEL	1	
	614405	PEDAL KIT, W/SPRG 18" MODEL	1	
▲	43	1015685	SPRING, PEDAL, 12" - 15" MODEL	1
	614406	SPRING, PEDAL, 18" MODEL	1	
▲	44	1015684	PEDAL, FOOT	1
45	1015736	SCREW KIT, 2.2X16, KIT=20 PCS	1	
46	1015738	●SWITCH	1	
47	1015670	SUPPORT, RIGHT	1	
48	1016508	COVER, 12", TEAL, W/LENS & LBL	1	
	1015678	COVER, 15", TEAL, W/LENS & LBL	1	
	1025307	COVER, 15", BLK, W/LENS & LBL	1	
	1015745	COVER, 18", TEAL, W/LENS & LBL	1	
49	614271	LABEL, TENNANT 3120 DM	1	
50	1015669	PIVOT, LATCH	1	
51	1015666	HOUSING, MOTOR	1	
52	1015667	GASKET, CONVEYOR	1	
53	1015664	TUBE, CONVEYOR	1	
54	1015663	SEAL, O-RING	1	

- ▽ ASSEMBLY / ENSEMBLE / CONJUNTO
- ▲ INCLUDED IN ASSEMBLY / Y COMPRIS EN ENSEMBLE / INCLUIDO A CONJUNTA

- RECOMMENDED STOCK ITEM / ÉLÉMENTS DE STOCK RECOMMANDÉS / PIEZAS RECOMENDADAS EN ALMACÉN

DUAL MOTOR ELECTRICAL DIAGRAM (120V)

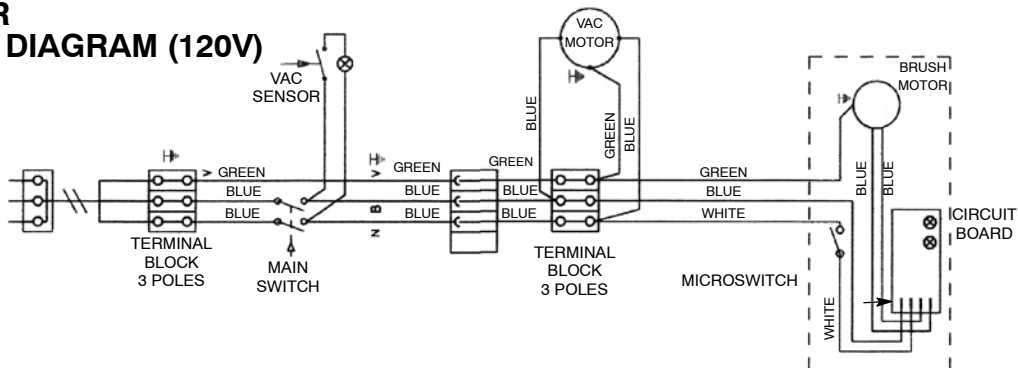



3110 and 3120 Upright Vacuum Cleaners

U.S. AND CANADIAN NEW MACHINE WARRANTY POLICY

Our Commitment to Customer Satisfaction

The warranty terms outlined below are in lieu of any other warranties, either expressed or implied, including any implied warranty of merchantability, fitness for a particular purpose or otherwise. Under no circumstances will seller be liable for any loss, damage, expense or consequential damages arising in connection with the use or inability to use, these products.

This warranty does not apply to damage or defect caused by accident, misuse, negligence, abuse, fire or to any Tennant product that has been serviced by anyone other than an authorized Tennant service representative. Housings or parts that have become damaged as a result of improper use of the machine are excluded from this warranty. Refer to Owner's Manual for proper machine use and maintenance. Parts that are expected to wear from normal use and, therefore, are not covered under the warranty include: handle, wheels, brush; filters; nozzles, hoses, switch, paper bags, power cord and motor carbon brushes.

This warranty commences on the date of purchase of the product by the original end user from an authorized Tennant sales representative, subject to proof of purchase. **A Machine Warranty Registration and Survey Reply Card included with the Owner's Manual must be completed and returned immediately at the time of purchase.** If proof of purchase date is unavailable, the warranty begins 90 days after the sale of the product to an authorized Tennant dealer.

Subject to the conditions outlined above, Tennant warrants the 3110 and 3120 models to be free from defects in materials and workmanship under normal use and service for one year, and further warrants, on a limited basis for three years, the belts and electric motors not subject to wear, to the original buyer. Electric motors subject to carbon brush wear, their durability depends on the numbers of hours of use and on the established substitution of filters. It does not depend on the years of life of the machine. The eventual substitution of the motor under warranty will therefore be effected only in case of production defect (this has to be verified by an authorized Tennant service center) and not in the case of total wear.

Parts replaced under this warranty are guaranteed for the remainder of the original warranty period or 90 days, whichever comes first, to the original end user.

Date Purchased: _____

Model Number: _____

Serial Number: _____

Please make sure to record this information. This information will be necessary for future warranty claims.

Tennant reserves the right to change its warranty policy without notice.