

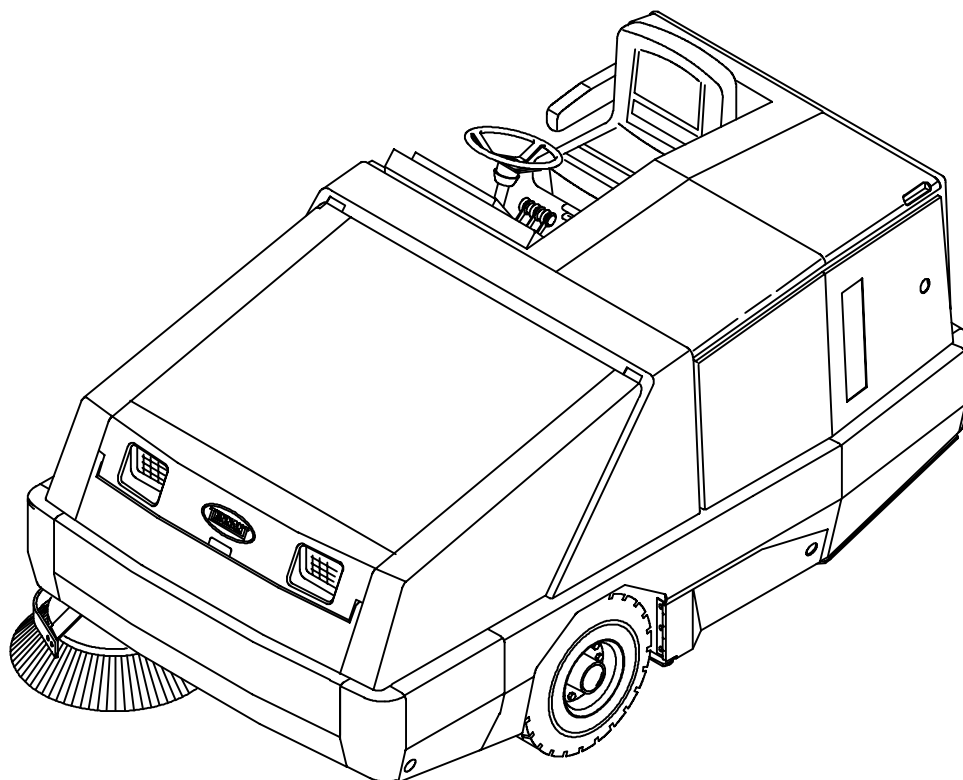

800

Parts Manual



MM307



This manual is furnished with each new TENNANT Model 800.

This manual consists of the How To Use This Manual; Standard Parts; Options; Breakdowns; 61854 Engine Breakdown; 83652 Engine Breakdown; and Cross Reference sections.

MACHINE DATA

Please fill out at time of installation for future reference.

Machine Model number – 800

Machine Serial number – _____

Machine Options – _____

TE A T Representative phone no. – _____

Customer ID number – _____

Date of Installation – _____

Manual number – MM307

Revision: 07

Published: 11–95

HOW TO USE THIS MANUAL

This section on *HOW TO USE THIS MANUAL* will tell you how to:

- Find important machine information for ordering correct repair parts.
- Find TENNANT part numbers.
- Order TENNANT parts and supplies.

IMPORTANT INFORMATION

When placing an order for parts, the machine model and machine serial number are important. Refer to the *MACHINE DATA* box which is filled out during the installation of your machine. The *MACHINE DATA* box is located on the inside of the front cover of this manual.

MACHINE DATA	
<i>Please fill out at time of installation for future reference.</i>	
Machine Model Number -	800
Machine Serial Number -	_____
Machine Options -	_____
TENNANT Representative/phone no. -	_____
Customer ID Number -	_____
Date of Installation -	_____
Manual Number -	MM307
Revision:	00
Published:	1-93

The model number of your machine is on the side of the machine.

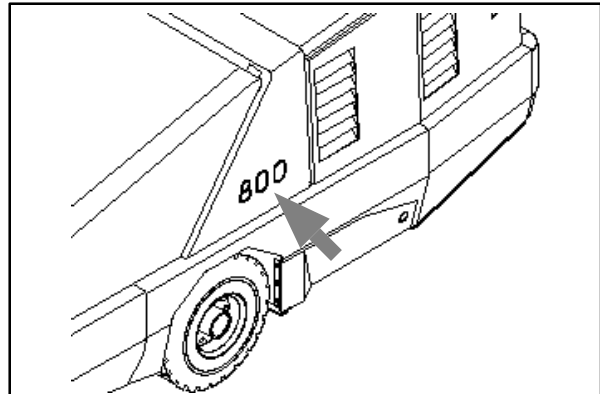

The serial number of your machine is printed on the machine data plate located as shown.

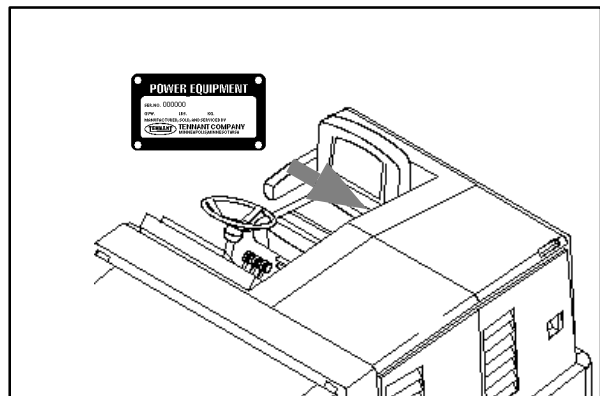

HOW TO USE THIS MANUAL

FINDING A TENNANT PART NUMBER

This manual contains the following sections:

- HOW TO USE THIS MANUAL
- STANDARD PARTS
- OPTIONS
- BREAKDOWNS
- CROSS REFERENCE

The STANDARD PARTS section lists repair parts for standard machines. They are grouped in this general order:

- General wear parts.
- Machine frame and related parts.
- Machine propelling system.
- Scrubbing components.
- Electrical parts.

The OPTION section lists repair parts of options.

The BREAKDOWN section lists available repair parts of major components.

All sections in this manual consist of parts illustrations and corresponding parts lists.

The parts illustrations are numbered with **Ref** numbers which refer to corresponding parts lists.

The parts lists include a number of columns of information:

- **Ref** – column refers to the reference number on the parts illustration.
- ▽ – indicates the part is an assembly.
- indicates the part is included in the assembly listed just before it.
- **TENNANT Part No.** – column lists the TENNANT part number for the part.
- **Serial Number** – column indicates the set of machines the part number is applicable to. Serial numbers change when the machine design has been modified. The most current design of the machine is shown in the main illustration, older designs are boxed in a corner of the illustration.
- **Description** – column is a brief description of the part.
- **Qty.** – column lists the quantity of that part used in that area of the machine.

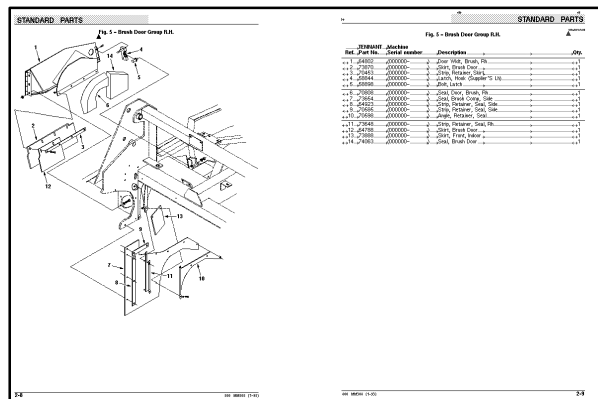

Ref.	Part No.	Serial number	Description	Qty.
6	59970	000000	Replm Kit, Instr Panel	1
1	59976	000000	Replm Kit, Case	1
2	59977	000000	Replm Kit, Seal	1
3	59974	000000	Replm Kit, Cir Board	1
4	59978	000000	Replm Kit, Hourmeter	1
5	59979	000000	Replm Kit, Touch Panel	1
6	59971	000000	Replm Kit, Lamp, Backlighting (C)	2
7	65346	000000	Replm Kit, Lamp (S)	1
8	10632-5	000000	Grommet, Rbr, 0.25Id, For .09Matl.	4
9	61969	000000	Switch, Rocker, Dpst	1
10	57807	000000	Cover, Rocker Switch Seal	1
11	87536	000000	Switch Ignition	1
12	87866	000000	Key Set, Switch Ku	1
13	72109	000000	Replm Kit, Sun Shield	1
14	65245	000000	Panel, Cover, Dash	1
15	70637	000000	Seal, Handle, Valve	1

NOTE: If a service kit is installed on your machine, be sure to keep the INSTRUCTION BULLETIN which came with the kit. It contains repair parts numbers needed for ordering future parts.

NOTE: Fasteners used in this machine may be metric or non-metric. Take care when replacing hardware to replace with same thread size.

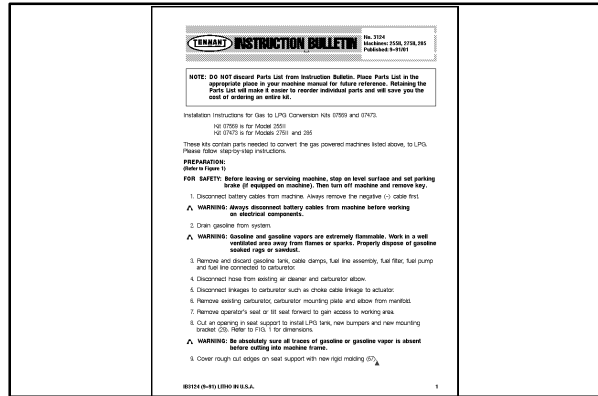

PLACING AN ORDER

Orders may be placed by phone, fax, or by mail. Phone orders may need written confirmation. Follow the steps below to insure prompt delivery:

1. Identify the model number of your machine.
2. Identify the serial number of your machine.
3. Find the part number of the part you need. Do not order by page number or reference number. If you are not able to find the part number, call your TARRANT representative for help or send the old part as a sample.
4. Determine the quantity of the part you need.
5. Provide the following company information:
 - Company name
 - Customer ID Number
 - Shipping address
 - Billing address
 - First and last name of person ordering parts
 - Telephone number
 - Purchase order number
6. Provide definitive shipping instructions.

HOW TO USE THIS MANUAL

Any claim for loss or damage to a shipment in transit should be filed promptly with the transportation company making the delivery. Shipments will be complete unless the packing list or order acknowledgement indicates items back ordered.

If parts received are suspected to be incorrect or defective, please contact the TENNANT representative from whom you ordered the part. They will give authorization for return and/or handle replacement shipments when required.

SECTION 2

CONTENTS

	PAGE
Fig. 1 – Recommended General Maintenance Items	2-3
Fig. 2 – Replacement Brushes	2-4
Fig. 3 – Main Frame, Skirt and Seals Group	2-6
Fig. 4 – Main Frame, Skirt and Seals Group	2-8
Fig. 5 – Left Brush Door Group	2-10
Fig. 6 – Right Brush Door Group	2-11
Fig. 7 – Operator Station Group	2-12
Fig. 8 – Operator Station Group	2-14
Fig. 9 – Engine Cover and Lintel Group	2-16
Fig. 10 – Engine Cover and Lintel Group	2-18
Fig. 11 – Engine Side Door Group	2-20
Fig. 12 – Engine Side Door Group	2-22
Fig. 13 – Grille and Hydraulic Cooler Group	2-24
Fig. 14 – Hopper Lift Arms Group	2-26
Fig. 15 – Hopper Lift Arms Group	2-28
Fig. 16 – Hopper Lift Cylinders Group	2-30
Fig. 17 – Hopper Lift Cylinders Group	2-32
Fig. 18 – Hopper Group	2-34
Fig. 19 – Hopper Group	2-36
Fig. 20 – Hopper Door Group	2-38
Fig. 21 – Hopper Door Group	2-40
Fig. 22 – Hopper Cover Group	2-42
Fig. 23 – Hopper Cover Group	2-44
Fig. 24 – Hopper Bumper Group	2-46
Fig. 25 – Hopper Bumper Group	2-48
Fig. 26 – Filter Shaker Group	2-50
Fig. 27 – Pressure Switch Group	2-52
Fig. 28 – Engine and Alternator Group	2-54
Fig. 29 – Engine and Alternator Group	2-56
Fig. 30 – Engine Mount Group	2-58
Fig. 31 – Engine Mount Group	2-60
Fig. 32 – Engine Mount Group	2-62
Fig. 33 – Carburetor and Governor Group, Gasoline	2-64
Fig. 34 – Carburetor and Governor Group, Gasoline	2-66
Fig. 35 – Carburetor and Governor Group, LPG	2-68
Fig. 36 – Carburetor and Governor Group, LPG	2-70
Fig. 37 – Vaporizer Group, LPG	2-72
Fig. 38 – Vaporizer Group, LPG	2-74
Fig. 39 – Air Cleaner Group, Gasoline	2-76
Fig. 40 – Air Cleaner Group, Gasoline	2-78
Fig. 41 – Air Cleaner Group, Gasoline	2-80
Fig. 42 – Air Cleaner Group, LPG	2-82
Fig. 43 – Air Cleaner Group, LPG	2-84
Fig. 44 – Air Cleaner Group, LPG	2-86
Fig. 45 – Muffler Group	2-88
Fig. 46 – Fuel Tank Group, Gas	2-90
Fig. 47 – Fuel Tank Group, Gas	2-92
Fig. 48 – Fuel Tank Group, LPG	2-94
Fig. 49 – Radiator Hose Group	2-96
Fig. 50 – Radiator Group	2-98
Fig. 51 – Radiator Group	2-100
Fig. 52 – Cooling Fan and Housing Group	2-102
Fig. 53 – Cooling Fan and Housing Group	2-104

Continued

STANDARD PARTS

Fig. 54 – Battery Group, Gasoline	2-106
Fig. 55 – Battery Group, LPG	2-107
Fig. 56 – Battery Group, Gasoline and LPG	2-108
Fig. 57 – Rear Wheel Drive Group	2-110
Fig. 58 – Front Wheels and Brakes Group	2-112
Fig. 59 – Wheel Assembly	2-114
Fig. 60 – Brake Pedals Group	2-116
Fig. 61 – Directional Pedal Group	2-118
Fig. 62 – Hydraulic Pumps Group	2-120
Fig. 63 – Hydraulic Schematic (for machines below serial number xxxxxx)	2-122
Fig. 64 – Hydraulic Schematic (for machines serial number xxxxxx and above)	2-123
Fig. 65 – Hydraulic Hose Group (for machines below serial number xxxxxx)	2-124
Fig. 66 – Hydraulic Hose Group (for machines serial number xxxxxx and above)	2-126
Fig. 67 – Hydraulic Reservoir Group	2-128
Fig. 68 – Hydraulic Solenoid Valve Group	2-130
Fig. 69 – Hydraulic Lift Valve Group	2-132
Fig. 70 – Hydraulic Lift Valve Group	2-134
Fig. 71 – Side Brush Group	2-136
Fig. 72 – Side Brush Lift Group	2-138
Fig. 73 – Side Brush Lift Group	2-140
Fig. 74 – Main Brush Drive Group	2-142
Fig. 75 – Main Brush Lift Group	2-144
Fig. 76 – Main Brush Adjustment Group	2-146
Fig. 77 – Main Brush Adjustment Group	2-148
Fig. 78 – Vacuum Fan Impeller Group	2-150
Fig. 79 – Vacuum Fan Impeller Group	2-152
Fig. 80 – Vacuum Fan Motor Group	2-154
Fig. 81 – Steering Group	2-156
Fig. 82 – Instrument Panel Assembly	2-158
Fig. 83 – Circuit Breaker and Relay Group	2-160
Fig. 84 – Electrical Schematic (For machines below serial number 1700)	2-162
Fig. 85 – Electrical Schematic (For machines serial number 1700 and above)	2-166
Fig. 86 – Wire Harnesses Group (For machines below serial number 1700)	2-170
Fig. 87 – Wire Harnesses Group (For machines serial number 1700 and above)	2-177
Fig. 88 – Label Group	2-184

Fig. 1 – Recommended General Maintenance Items

Ref.	Tennant Part No.	Machine Serial Number	Description	Qty.
▽	77632	(000000–)	Maintenance Kit, Skirts	1
	73870	(000000–)	Skirt, Brush Door	2
	64788	(000000–)	Skirt, Brush Door	2
	70453	(000000–)	Strip, Retainer, Skirt	2
	62955	(000000–)	Skirt, Seal, Main Brush	1
	62957	(000000–)	Channel, Retainer, Seal, Rear	1
	62954	(000000–)	Blade, Deflector	1
	62956	(000000–)	Strap, Retainer, Seal	1
	43500	(000000–)	Chain, Link#2/0, 7Links	1
▽	79032	(000000–)	Maintenance Kit, Skirts 800	1
	64919	(000000–)	Seal, Pan, Top	1
	64920	(000000–)	Channel, Retainer	1
	73654	(000000–)	Seal, Brush Comp, Side	2
	73888	(000000–)	Skirt, Front, Indoor	2
▽	79038	(000000–)	Maintenance Kit, 400HR 800/810 gas/lpg	1
	39703–2	(000000–)	Filter Element, Oil, Cont. Gas–SE	4
	60846	(000000–)	Spark Plug–10 FD	4
	35993	(000000–)	Valve, PCV	1
▽	77634	(000000–)	Maintenance Kit, 800HR 800/810	1
	34306	(000000–)	Breather, Hyd 40Mic NO DS	1
	31613	(000000–)	Strainer–Hyd Suction 25–100–03	1
	10664	(000000–)	Filter Assy, Spin–on	1
	65869–5	(000000–)	Fluid, Hyd Oil, SHP 15/40 5Gal	3

Fig. 2 – Replacement Brushes

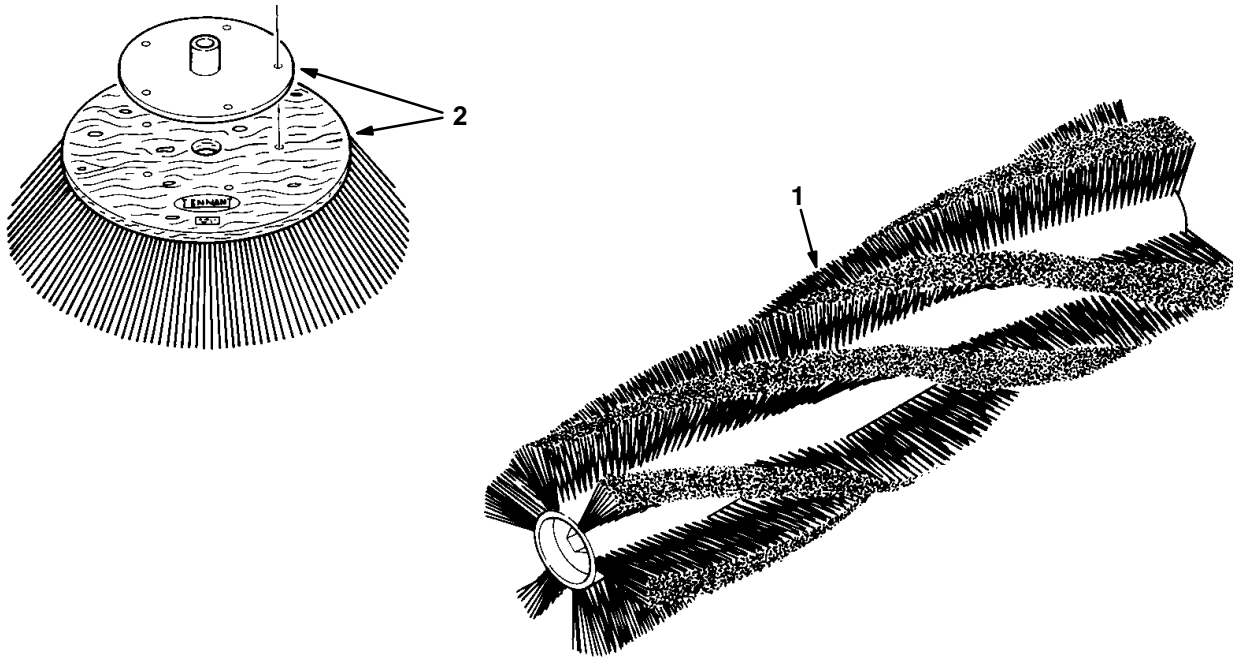

Fig. 2 – Replacement Brushes

1 370011..... BRUSH, SWP, 50L, WEDGE, PYP ,SPL1

Ref.	Tennant Part No.	Machine Serial Number	Description	Qty.
1	35326	(000000–)	Brush–Sweep Spl–50Lg – 8Dr–Poly	1
1	35324	(000000–)	Brush–Sweep Spl–50Lg–8Dr–P&W	1
1	35327	(000000–)	Brush–Sweep Spl–50Lg–8Dr–Wire	1
1	35325	(000000–)	Brush–Outsd Spl–50Lg – 8Dr–Poly	1
1	35336	(000000–)	Brush–Patrl Spl–50Lg – 4Qr–Nyl	1
1	35323	(000000–)	Brush–Sweep Spl–50Lg–24Sr–Nyl	1
∇	2	75011	(000000–) Brush–Side Swp –26 D–Assy–Nyl	1
		51021N	(000000–) Brush–Side Swp –26 D–Nyl	1
		51963	(000000–) Adaptor Weldm., Side Brush 1.0B	1
∇	2	75010	(000000–) Brush–Side Swp –26 D–Assy–Fltw	1
		51542	(000000–) Brush–Side Swp –26 D–Fltw	1
		51963	(000000–) Adaptor Weldm., Side Brush 1.0B	1
∇	2	70649	(000000–) Brush–Side Swp –26 D–Assy–Poly	1
		70538	(000000–) Brush–Side Swp –26 D–Poly	1
		51963	(000000–) Adaptor Weldm., Side Brush 1.0B	1

Fig. 3 – Main Frame, Skirt and Seals Group

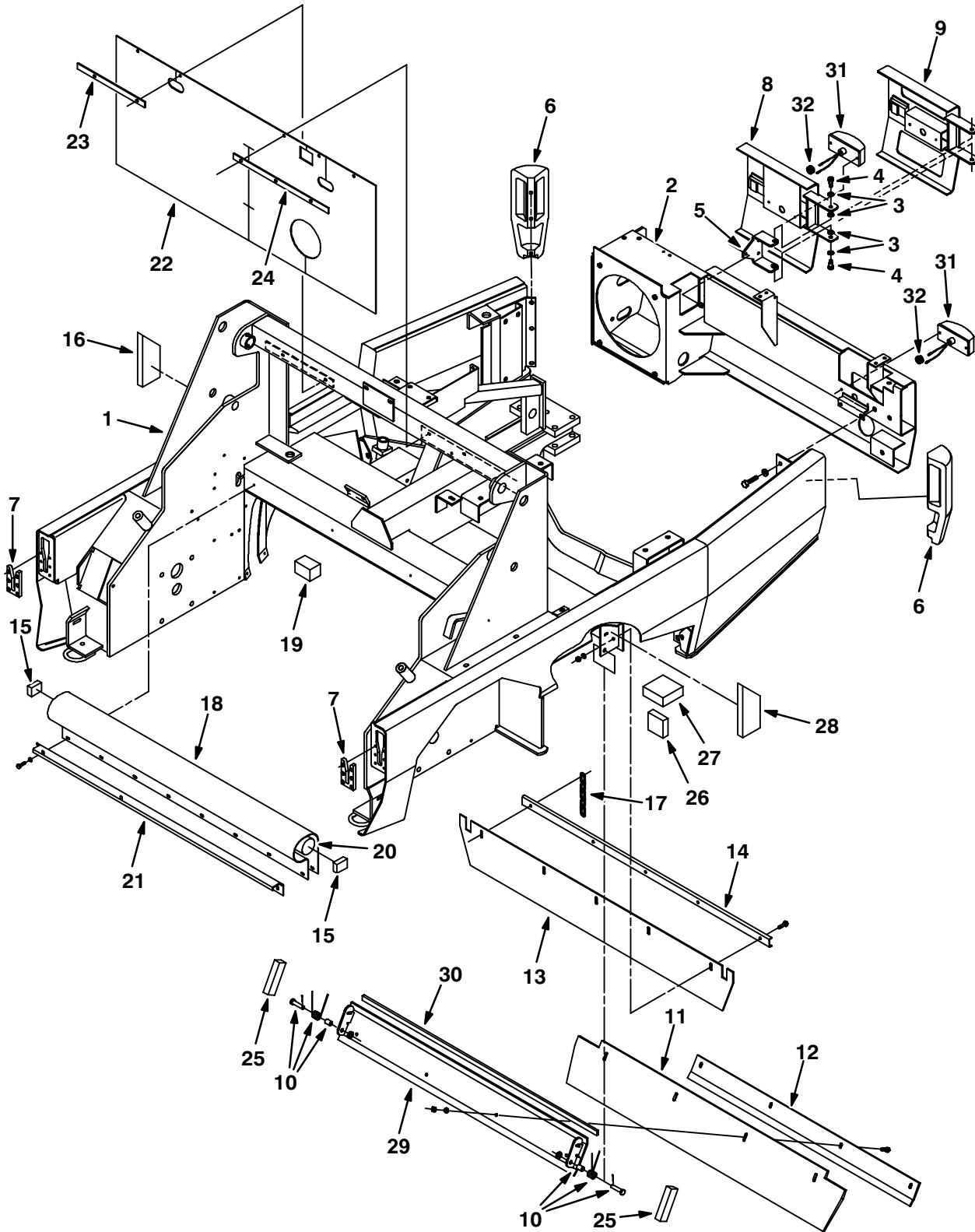

Fig. 3 – Main Frame, Skirt and Seals Group

Ref.	Tennant Part No.	Machine Serial Number	Description	Qty.	
1	62960	(000000-001131)	Frame Wldt	1	
2	70451	(000000-001223)	Bumper Wldt, Rear	1	
3	86860	(000000-001223)	Bearing, Thrust .500	4	
4	36758	(000000-001223)	Scr-Shld .500Dx0.50L .38-16	2	
5	70517	(000000-001223)	Bracket	1	
6	63544	(000000-001223)	Bumper, Corner, Mach	2	
7	63663	(000000-001223)	Plate, Guide, Bumper	2	
8	77690	(000000-001223)	Replacement Kit, Battery Door (Gasoline)	1	
9	77690	(000000-001223)	Replacement Kit, Battery Door (LPG)	1	
10	69904	(000000-001223)	Spring Assy, Recirculation	2	
11	62954	(000000-001223)	Blade, Deflector	1	
12	62956	(000000-001223)	Strap, Retainer, Seal	1	
13	62955	(000000-001223)	Skirt, Seal, Main Brush	1	
14	62957	(000000-001223)	Channel, Retainer, Seal, Rear	1	
15	82125	(000000-001223)	Seal, Foam Rbr .75 1.5W 2.1L	2	
16	74066	(000000-001223)	Seal, Foam	1	
17	43500	(000000-001223)	Chain,Link#2/0,7Links	1	
18	64919	(000000-001223)	Seal, Pan, Top	1	
19	73722	(000000-001223)	Seal, Main Brush	2	
20	34690	(000000-001223)	Sponge Cord 1.5Dia	1	
21	64920	(000000-001223)	Channel, Retainer	1	
22	73724	(000000-001223)	Shield, Dust	1	
23	70843	(000000-001223)	Strip, Retainer, Shield, Rh	1	
24	70844	(000000-001223)	Strip, Retainer, Shield, Lh	1	
25	74064	(000000-001223)	Seal, Foam	2	
26	73863	(000000-001223)	Insulation,S/Foam1.0X 3.0X 3.0	2	
27	73862	(000000-001223)	Insulation,S/Foam1.5X 4.0X 4.0	2	
28	74067	(000000-001223)	Seal, Foam	1	
29	73645	(000000-001223)	Channel Wldt, Mtg	1	
30	74038	(000000-001223)	Seal, Foam	1	
∇	31	57941	(000000-001223)	Light Assy Stop/Red 12V- A	2
		45780	(000000-001223)	Bulb, 12V .5A 4CP#1157	1
	32	87515	(000000-001223)	Grommet, Rbr, .50 ID, For .25 Matl	2

Fig. 4 – Main Frame, Skirt and Seals Group

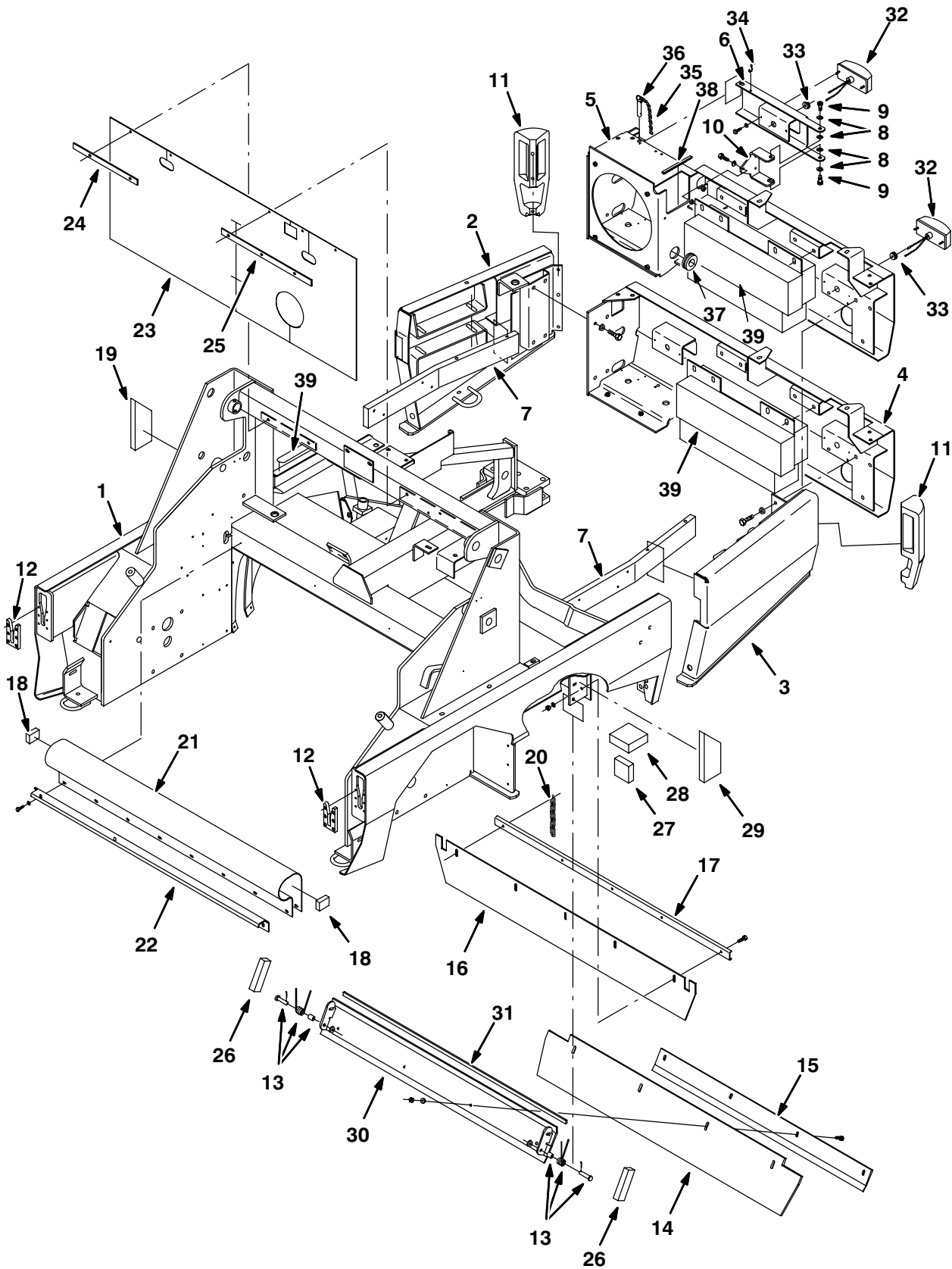

Fig. 4 – Main Frame, Skirt and Seals Group

Ref.	Tennant Part No.	Machine Serial Number	Description	Qty.
1	76555	(001132-001223)	Frame	1
1	77777	(001124-)	Frame	1
2	76464	(001132-001223)	Panel Wldt, Rear, Rh	1
2	77782	(001224-)	Panel Wldt, Rear, Rh	1
3	76465	(001132-001223)	Panel Wldt, Rear, Lh	1
3	77734	(001224-)	Panel Wldt, Rear, Lh	1
4	22022	(001224-001302)	Replm. Kit, Bumper, Gas	1
4	79680	(001303-)	Bumper Wldt., Rear, Gas/Die	1
5	22023	(001224-001302)	Replm. Kit , Bumper, LPG	1
5	79681	(001303-)	Bumper Wldt., Rear, LPG	1
6	77680	(001224-)	Door, Bumper, Lpg	1
7	77593	(001224-)	Bar, Frame	2
8	86860	(001224-)	Bearing, Thrust .500	4
9	36758	(001224-)	Scr-Shld .500Dx0.50L .38-16	2
10	70517	(001224-)	Bracket	1
11	63544	(001224-)	Bumper, Corner, Mach	2
12	63663	(001224-)	Plate, Guide, Bumper	2
13	69904	(001224-)	Spring, Recirculation	1
14	62954	(001224-)	Blade, Deflector	1
15	62956	(001224-)	Strap, Retainer, Seal	1
16	62955	(001224-)	Skirt, Seal, Main Brush	1
17	62957	(001224-)	Channel, Retainer, Seal,Rear	1
18	82125	(001224-)	Seal Foam Rbr .75 1.5W 2.1L	2
19	74066	(001224-)	Insulation, S/Foam	1
20	43500	(001224-)	Chain,Link#2/0,7Links	1
21	64919	(001224-)	Seal, Pan, Top	1
22	64920	(001224-)	Channel, Retainer	1
23	73724	(001224-)	Shield, Dust	1
24	70843	(001224-)	Strip, Retainer, Shield, Rh	1
25	70844	(001224-)	Strip, Retainer, Shield, Lh	1
26	74064	(001224-)	Insulation, S/Foam	2
27	73863	(001224-)	Insulation, S/Foam 1.0X3.0X3.0	2
28	73862	(001224-)	Insulation, S/Foam 1.5X4.0X4.0	2
29	74067	(001224-)	Insulation, S/Foam	1
30	73645	(001224-)	Channel, Mounting	1
31	79010	(001224-)	Seal	1
▽ 32	57941	(001224-)	Light Assy Stop/Red 12V- . A	2
	45780	(001224-)	Bulb, 12V .5A 4Cp #1157	1
33	87515	(001224-)	Grommet,Rbr,0.50ld,For .25Matl	2
34	43363	(001224-)	Hook, S-.120 X 1.31, Zinc Pl.	1
35	56506	(001224-)	Chain,Jack#18,39Links,Cad15.12	1
36	79608	(001224-)	Pin, Hitch .50D X 1.50L	1
37	74920	(001224-)	Grommet, Flexible .25	1
38	79670	(001224-)	Strip, Edging	1
39	79671	(001303-)	Weight, LPG/Gas	1

Fig. 5 – Left Brush Door Group

This part is drawn backwards. The long tab on top goes toward the front.

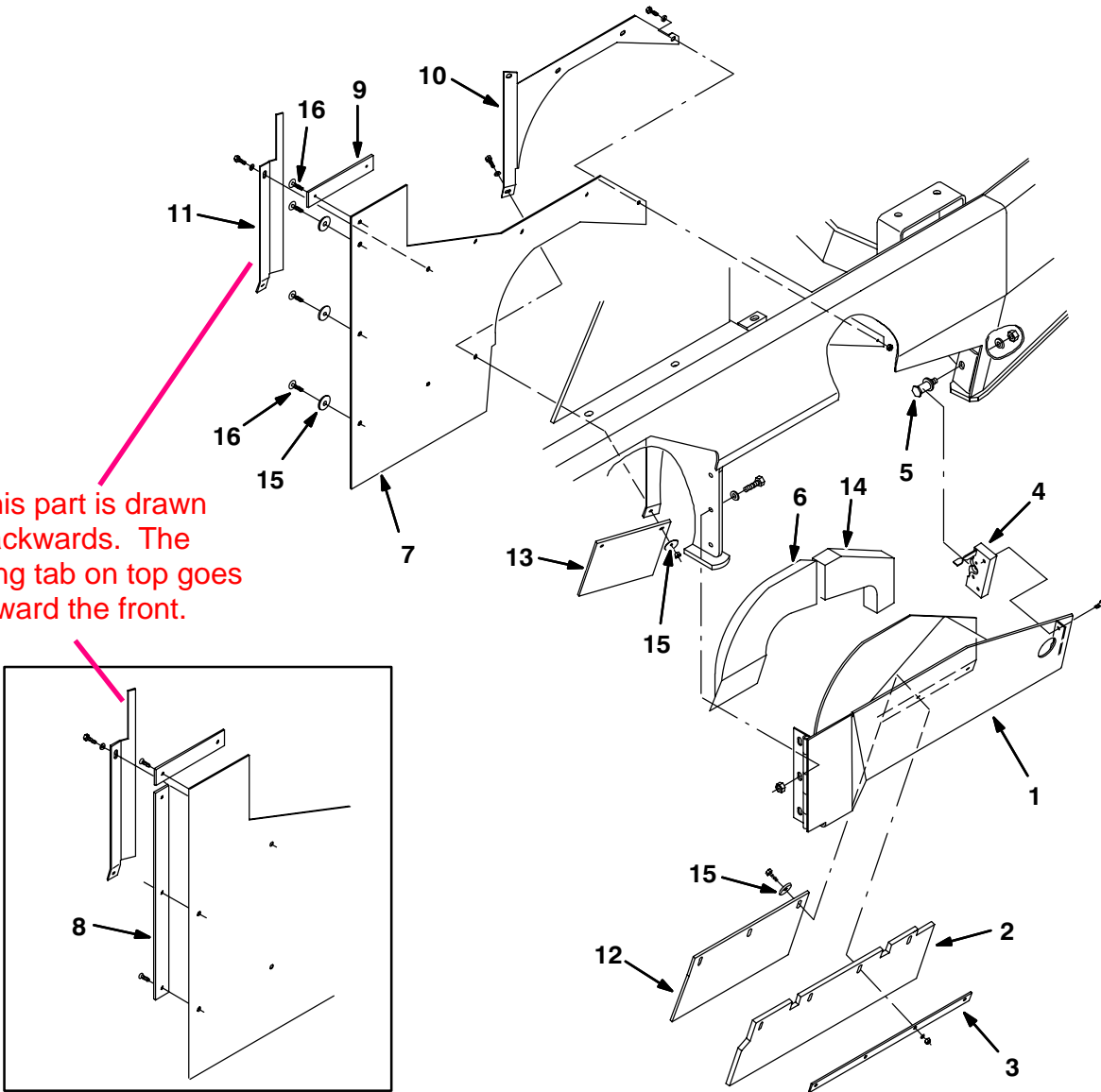

Fig. 5 – Left Brush Door Group

Ref.	Tenant Part No.	Machine Serial Number	Description	Qty.
1	64801	(000000–)	Door Wldt, Brush, Lh	1
2	73870	(000000–)	Skirt, Brush Door	1
3	70453	(000000–)	Strip, Retainer, Skirt	1
4	58489	(000000–)	Latch, Hook (Supplier'S Rh)	1
5	58898	(000000–)	Bolt, Latch	1
6	70809	(000000–)	Seal, Door, Brush, Lh	1
7	73654	(000000–)	Seal, Brush Comp, Side	1
8	64923	(000000–001320)	Strip, Retainer, Seal, Side	1
9	21282	(000000–)	Strip, Retainer, Seal, Side	1
10	70597	(000000–)	Angle, Retainer, Seal	1
11	73648	(000000–)	Strip, Retainer, Seal, Lh	1
12	64788	(000000–)	Skirt, Brush Door	1
13	73888	(000000–)	Skirt, Front, Indoor	1
14	74062	(000000–)	Seal, Brush Door	1
15	41178	(000000–)	Fender Washer	7
16	21168	(001321–)	Rivet, Plastic	5

Fig. 6 – Right Brush Door Group

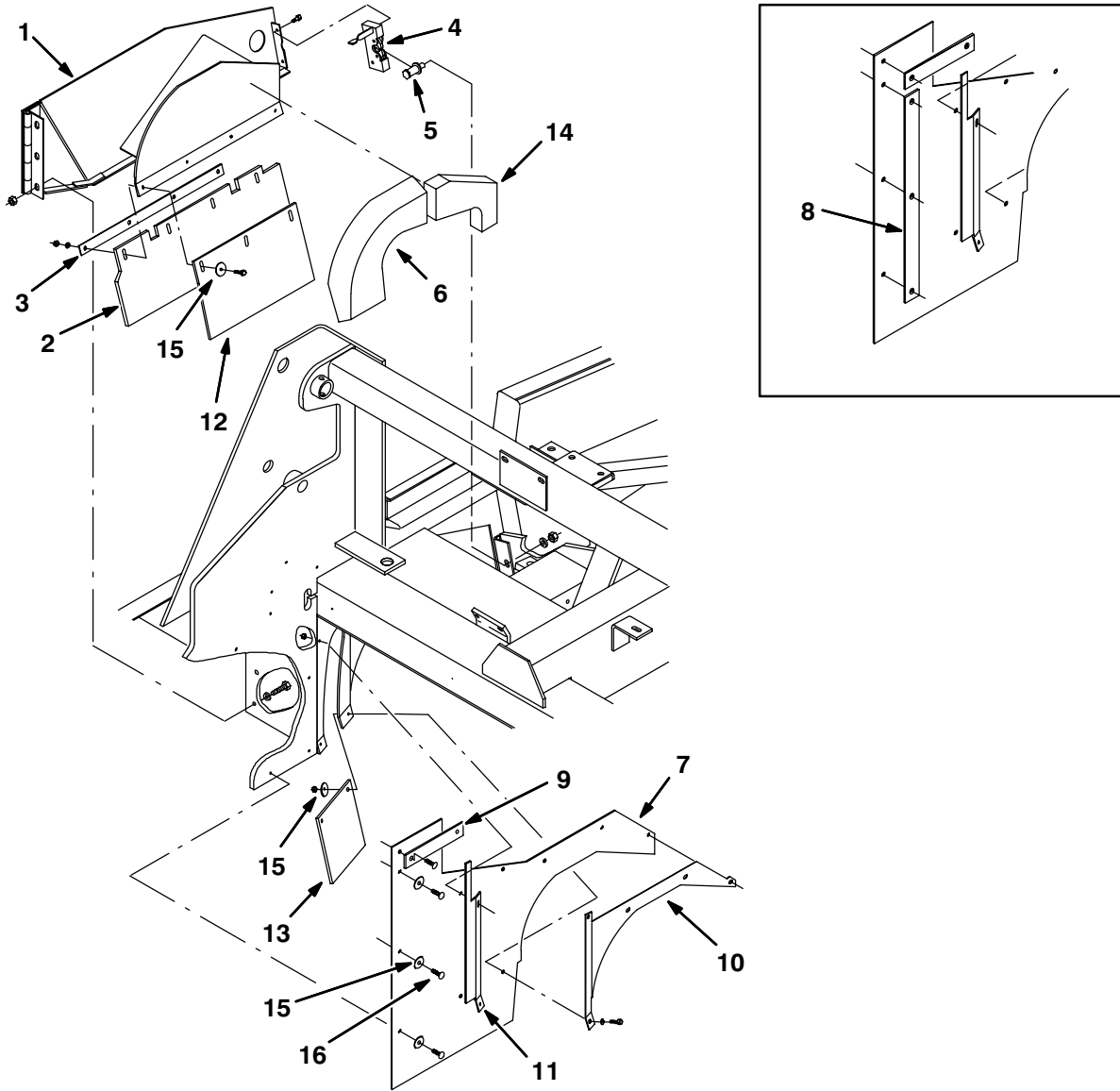

Fig. 7 – Right Brush Door Group

Ref.	Tenant Part No.	Machine Serial Number	Description	Qty.
1	64802	(000000–)	Door Wldt, Brush, Rh	1
2	73870	(000000–)	Skirt, Brush Door	1
3	70453	(000000–)	Strip, Retainer, Skirt	1
4	58844	(000000–)	Latch, Hook (Supplier's Lh)	1
5	58898	(000000–)	Bolt, Latch	1
6	70808	(000000–)	Seal, Door, Brush, Rh	1
7	73654	(000000–)	Seal, Brush Comp, Side	1
8	64923	(000000–001320)	Strip, Retainer, Seal, Side	1
9	21282	(000000–)	Strip, Retainer, Seal, Side	1
10	70598	(000000–)	Angle, Retainer, Seal	1
11	73649	(000000–)	Strip, Retainer, Seal, Rh	1
12	64788	(000000–)	Skirt, Brush Door	1
13	73888	(000000–)	Skirt, Front, Indoor	1
14	74063	(000000–)	Seal, Brush Door	1
15	41178	(000000–)	Fender Washer	7
16	21168	(001321–)	Rivet, Plastic	5

Fig. 8 – Operator Station Group

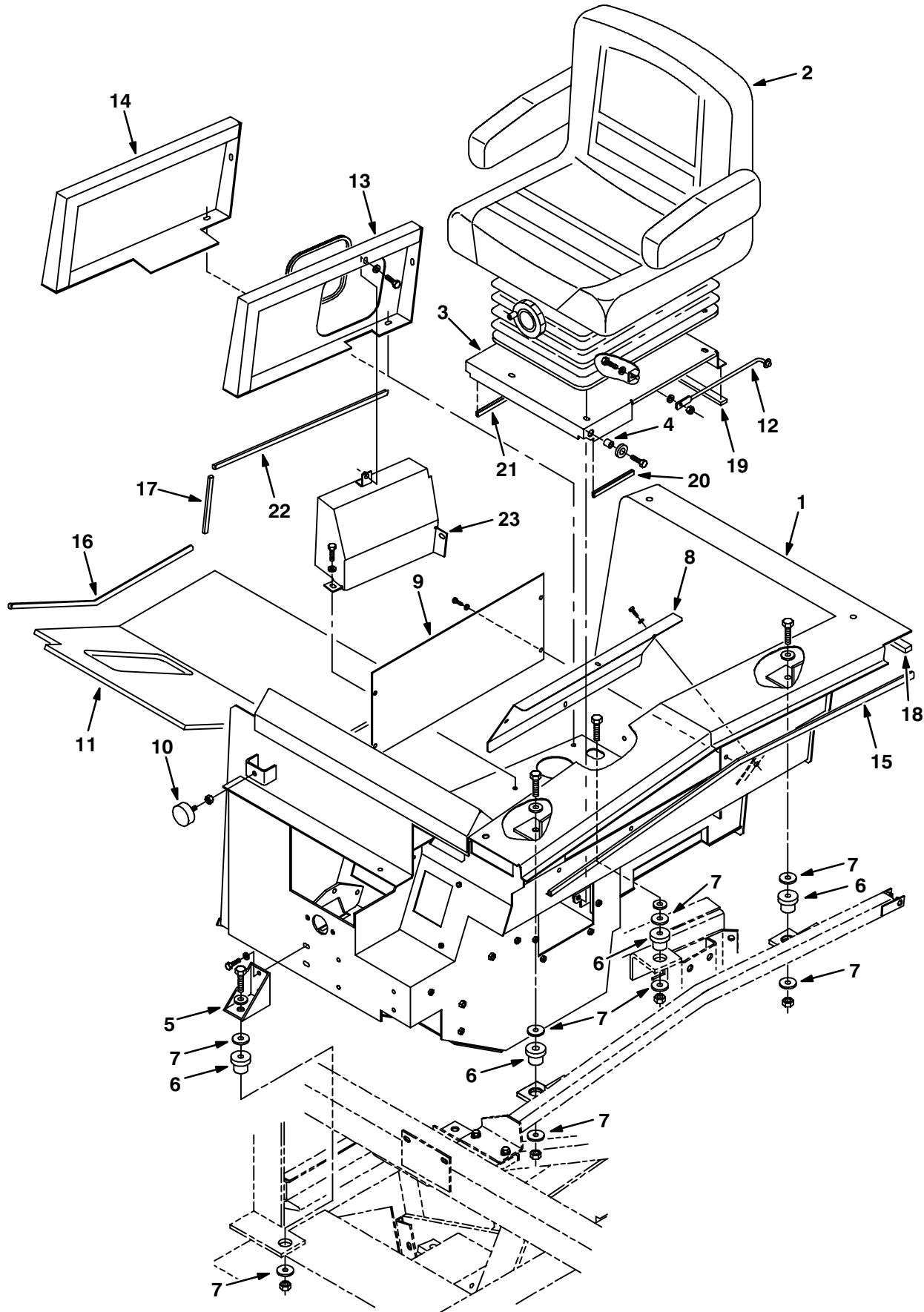

Fig. 8 – Operator Station Group

Ref.	Tenant Part No.	Machine Serial Number	Description	Qty.
1	63710	(000000–001119)	Panel Wldt, Oper Comp	1
2	63294	(000000–001119)	Seat, Suspension	1
3	70478	(000000–001119)	Panel Wldt, Support, Seat	1
4	40716	(000000–001119)	Sleeve, .385B .62D .62 Cd.Cad	2
5	63751	(000000–001119)	Bracket Wldt, Oper Comp	1
6	51176	(000000–001119)	Dampner, Engine	4
7	04414	(000000–001119)	Washer, Flat	8
8	64884	(000000–001119)	Panel, Cover, Access	1
9	70450	(000000–001119)	Panel, Air Conditioning	1
10	70756	(000000–001119)	Bumper, Rubber	1
11	73691	(000000–001119)	Tread, Floormat, Rubber	1
12	54615	(000000–001119)	Rod Wldt, Seat	1
13	70564	(000000–001119)	Panel, Fuel Inlet (Gasoline)	1
14	70704	(000000–001119)	Panel, Fuel Inlet (LPG)	1
15	57820	(000000–001119)	Seal, 48.0 Lg.	1
16	73903	(000000–001119)	Seal, 24.5 Lg	1
17	73901	(000000–001119)	Seal, 33.00 Lg	1
18	74081	(000000–001119)	Seal, 66.0 Lg	1
19	44777	(000000–001119)	Seal,Foam Rbr, .31 .75W 14.8L	1
20	57564	(000000–001119)	Molding, Trim 11–14Ga 5.00	1
21	62595–2	(000000–001119)	Molding, Trim 11–14Ga 15.75	1
22	04664	(000000–001119)	Seal, 27.25L	1
23	70620	(000000–001119)	Cover Wldt, Fuel Inlet (Gasoline)	1

Fig. 9 – Operator Station Group

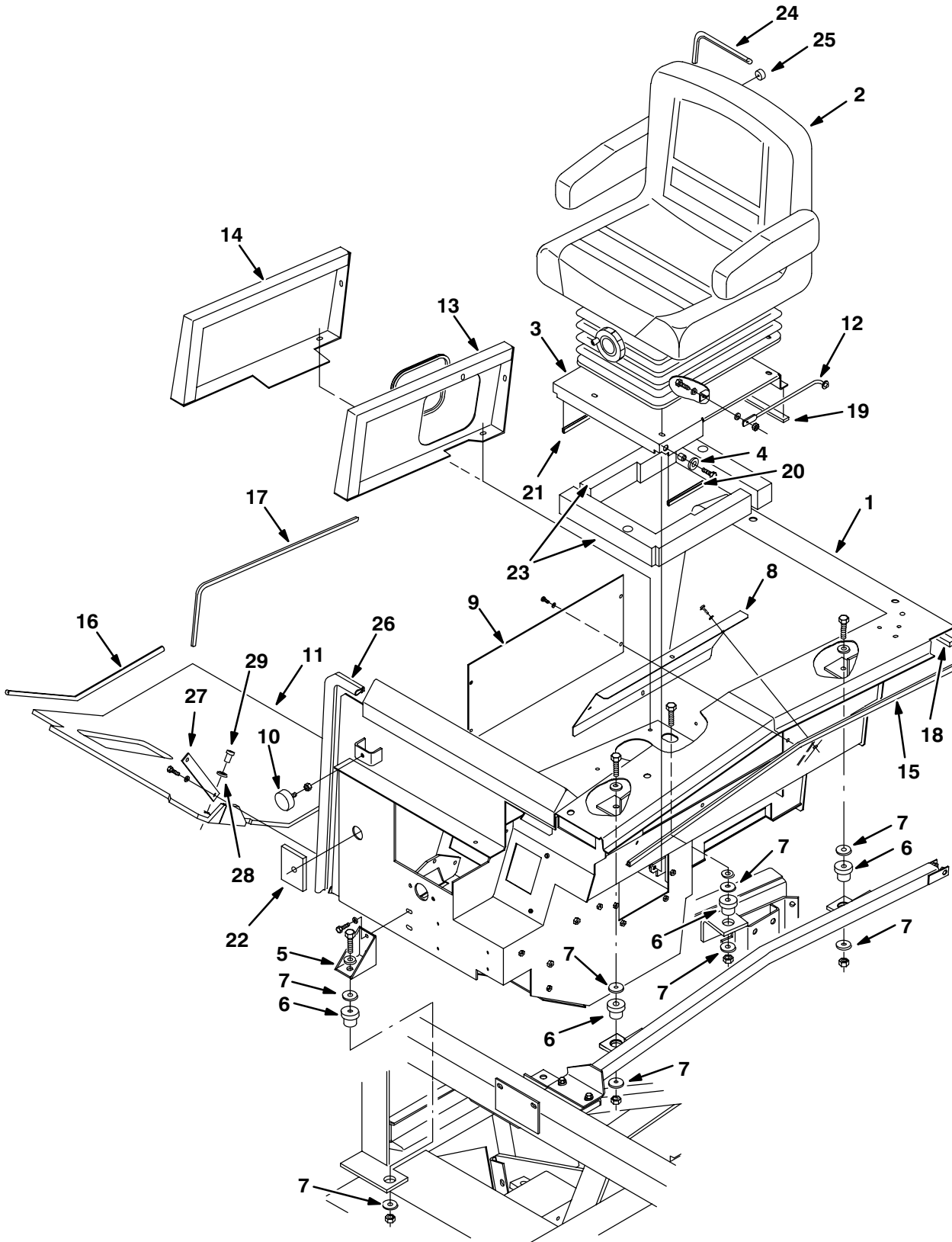

Fig. 9 – Operator Station Group

Ref.	Tenant Part No.	Machine Serial Number	Description	Qty.
1	75860	(001120–)	Panel Wldt W/Label	1
2	63294	(001120–)	Seat, Suspension	1
3	70478	(001120–)	Panel, Support, Seat	1
4	40716	(001120–)	Sleeve, .385B .62D .62 Cd.Cad	2
5	63751	(001120–)	Bracket, Oper Comp	1
6	51176	(001120–)	Dampner, Engine	4
7	04414	(001120–)	Washer, .531B 1.88D .12Hard Zn	8
8	64884	(001120–)	Panel, Cover, Access	1
9	70450	(001120–)	Panel, Air Conditioning	1
10	70756	(001120–)	Bumper, Rubber	1
11	76495	(001120–)	Tread, Floormat, Rubber	1
12	54615	(001120–)	Rod, Seat	1
13	70564	(001120–)	Panel, Fuel Inlet	1
14	70704	(001120–)	Panel, Fuel, Inlet, Lpg	1
15	57820	(001120–)	Seal, 48.0 Lg.	1
16	73903	(001120–)	Seal, Bulb, Sd–0504 24.50Lg	1
17	73901	(001120–)	Seal, 7.00 Lg	1
18	74081	(001120–)	Seal	1
19	44777	(001120–)	Seal,Foam Rbr, .31 .75W 14.8L	1
20	62595–3	(001120–)	Molding, Trim 11–14Ga 5.75	1
21	62595–2	(001120–)	Molding, Trim 11–14Ga 15.75	1
22	79028	(001120–)	Seal, Rod, Adjuster	1
23	76285	(001120–)	Insulation, S/Foam, Seat	2
24	49282	(001120–)	Molding, Trim 16Ga&Thinnr 10.0	1
25	82921	(001120–)	Bumper, Rubber	1
26	77340	(001120–)	Seal, Bulb, Sd–0504 28.00 Lg	1
27	76492	(001120–)	Bar, Retainer	1
28	41178	(001120–)	Washer–Flt .25 Fender Rltd.	1
29	21246	(001120–)	Rivet, Plastic .325D X .787	1

Fig. 10 – Engine Cover and Lintel Group

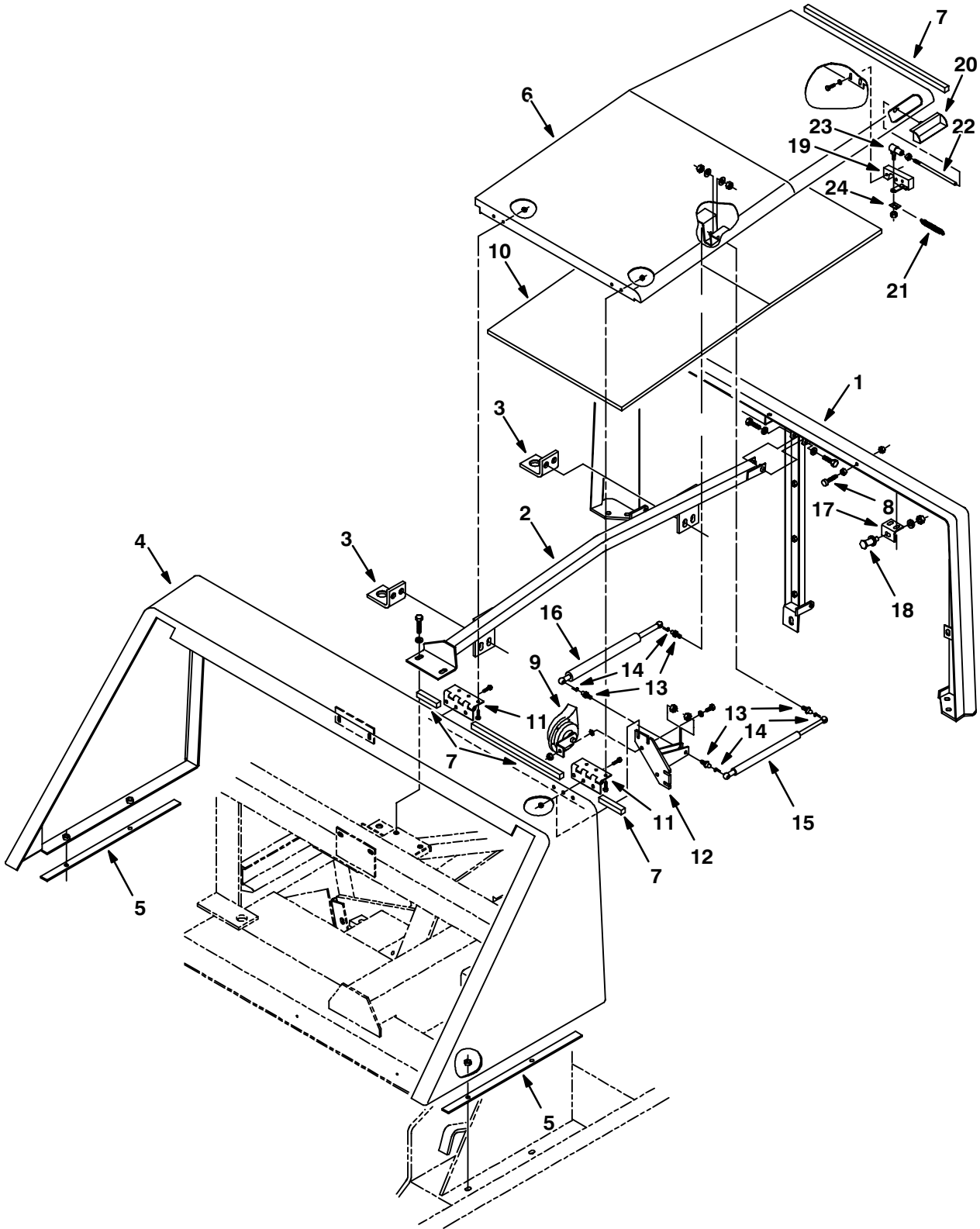

Fig. 10 – Engine Cover and Lintel Group

Ref.	Tenant Part No.	Machine Serial Number	Description	Qty.
1	64312	(000000-001251)	Lintel Wldt, Rear	1
2	64744	(000000-001251)	Tube Wldt, Brace, Center	1
3	64726	(000000-001251)	Bracket, Brace, Center	2
4	64278	(000000-001251)	Lintel Wldt, Main	1
5	64279	(000000-001251)	Strip, Spacer	2
6	64440	(000000-001251)	Cover Wldt, Engine	1
7	53461-2	(000000-001251)	Seal,Foam Rbr, .62 .62W 24.5L	2
8	75128	(000000-001251)	Spindle, Adjustment	1
9	14138A	(000000-001251)	Horn, 12V	1
10	70596	(000000-001251)	Insulation, S/Foam	1
11	74040	(000000-001251)	Hinge	2
12	65003	(000000-001251)	Bracket Wldt, Gas Spring	1
13	58494	(000000-001251)	Stud, Ball, Gas Spring	4
14	64595	(000000-001251)	Clip, Safety	4
15	31182	(000000-001251)	Spring-Gas 75Lb 6.3 Stroke	1
16	82334	(000000-001251)	Spring-Gas 120Lb 6.3 Stroke	1
17	70408	(000000-001251)	Angle, Bolt, Latch, Cover	1
18	59703	(000000-001251)	Bolt, Hook, Rh	1
19	59661	(000000-001251)	Latch	1
20	73841	(000000-001251)	Handle Wldt, Latch	1
21	29260	(000000-001251)	Sprng,Tens,0.37Odx.05Wire 4.5L	1
22	73843	(000000-001251)	Rod-Thrd, 1End M06X1.0 X 6.40	1
23	12263	(000000-001251)	Balljoint M 6X1.0	1
24	73893	(000000-001251)	Strip	1

Fig. 11 – Engine Cover and Lintel Group

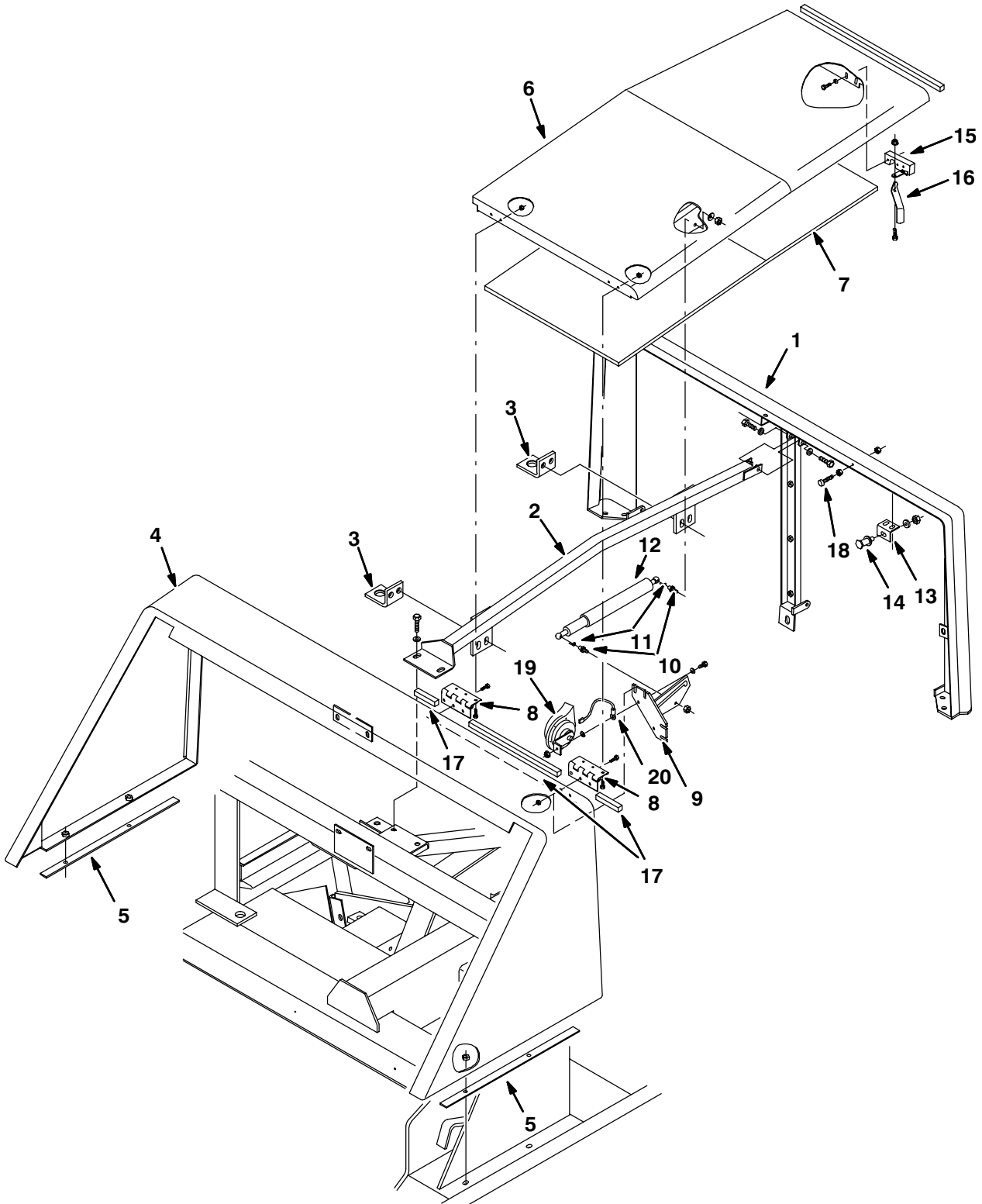

Fig. 11 – Engine Cover and Lintel Group

Ref.	Tenant Part No.	Machine Serial Number	Description	Qty.
1	64312	(001252–)	Lintel, Rear	1
2	64744	(001252–)	Tube Wldt, Brace, Center	1
3	64726	(001252–)	Bracket, Brace, Center	2
4	64278	(001252–)	Lintel, Main	1
5	64279	(001252–)	Strip, Spacer	2
6	79002	(001252–)	Cover Wldt, Engine	1
7	70596	(001252–)	Insulation, S/Foam	1
8	74040	(001252–)	Hinge	2
9	21131	(001252–)	Brkt Wldt , Gas Spring	1
10	58494	(001252–)	Stud, Ball, Gas Spring	2
11	64595	(001252–)	Clip Safety	2
12	77728	(001252–)	Spring, Gas	1
13	70408	(001252–)	Angle, Bolt, Latch, Cover	1
14	59703	(001252–)	Bolt, Hook, Rh	1
15	59661	(001252–)	Latch	1
16	79009	(001252–)	Lever, Handle, Latch	1
17	53461–2	(001252–)	Seal,Foam Rbr, .62 .62W 24.5L	2
18	75128	(001252–)	Spindle, Adjustment	1
19	21642	(001252–)	Horn, 12V	1
20	21643	(001252–)	Wire, Lead	1

Fig. 12 – Engine Side Door Group

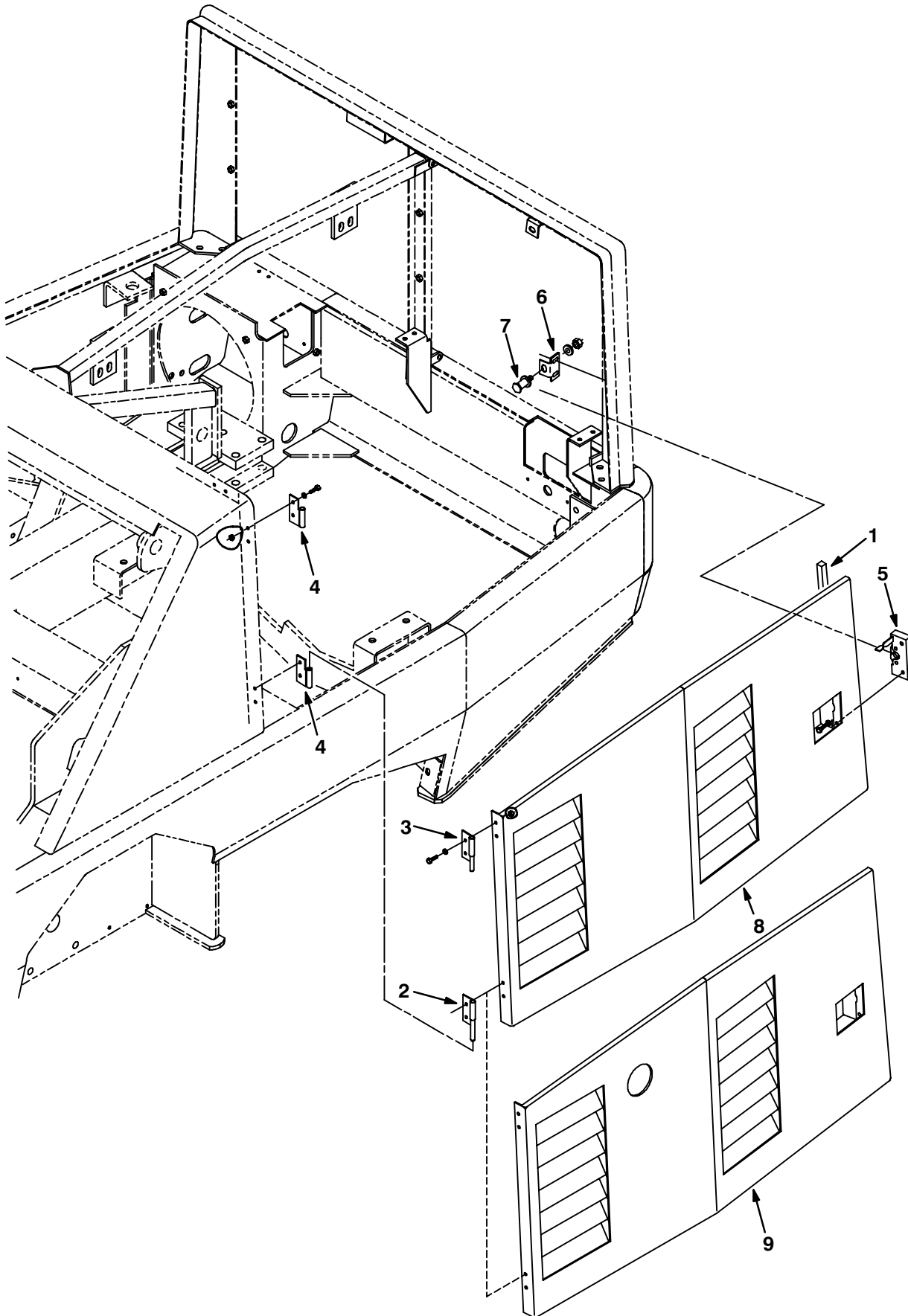

Fig. 12 – Engine Side Door Group

Ref.	Tennant Part No.	Machine Serial Number	Description	Qty.
1	53461-2	(000000-001169)	Seal,Foam Rbr, .62 .62W 24.5L	1
2	64543	(000000-001169)	Hinge Wldt, W/Pin	1
3	70628	(000000-001169)	Hinge Wldt, W/Pin	1
4	64545	(000000-001169)	Hinge Wldt	2
5	58489	(000000-001169)	Latch, Hook (Supplier'S Rh)	1
6	70407	(000000-001169)	Angle, Bolt, Latch	1
7	59192	(000000-001169)	Latch, Bolt	1
8	70410	(000000-001169)	Door Wldt, Engine (Gasoline)	1
9	73732	(000000-001169)	Door Wldt, Engine (LPG)	1

Fig. 13 – Engine Side Door Group

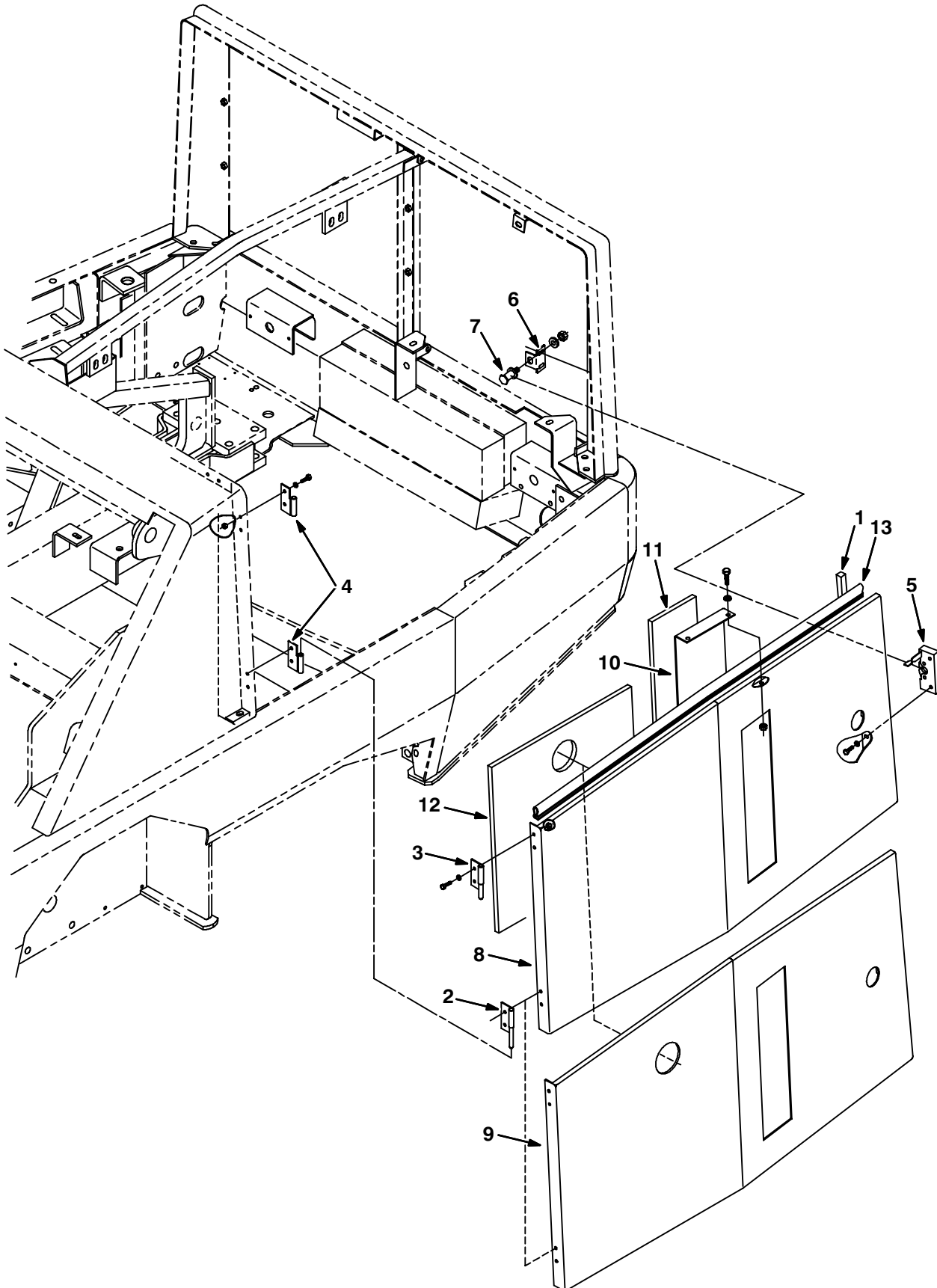

Fig. 13 – Engine Side Door Group

Ref.	Tennant Part No.	Machine Serial Number	Description	Qty.
1	53461-2	(001170-) Seal,Foam Rbr, .62 .62W 24.5L	1
2	64543	(001170-) Hinge, W/Pin	1
3	70628	(001170-) Hinge, W/Pin	1
4	64545	(001170-) Hinge	2
5	58489	(001170-) Latch, Hook Rh	1
6	70407	(001170-) Angle, Bolt, Latch	1
7	59192	(001170-) Latch, Bolt	1
8	77470	(001170-) Door Wldt, Engine	1
9	77469	(001170-) Door Wldt, Engine, Lpg	1
10	77467	(001170-) Panel	1
11	77630	(001170-) Insulation, S/Foam	1
12	77642	(001170-) Insulation, S/Foam	1
13	57820	(001170-) Seal, 48.0 Lg.	1

Fig. 14 – Grille and Hydraulic Cooler Group

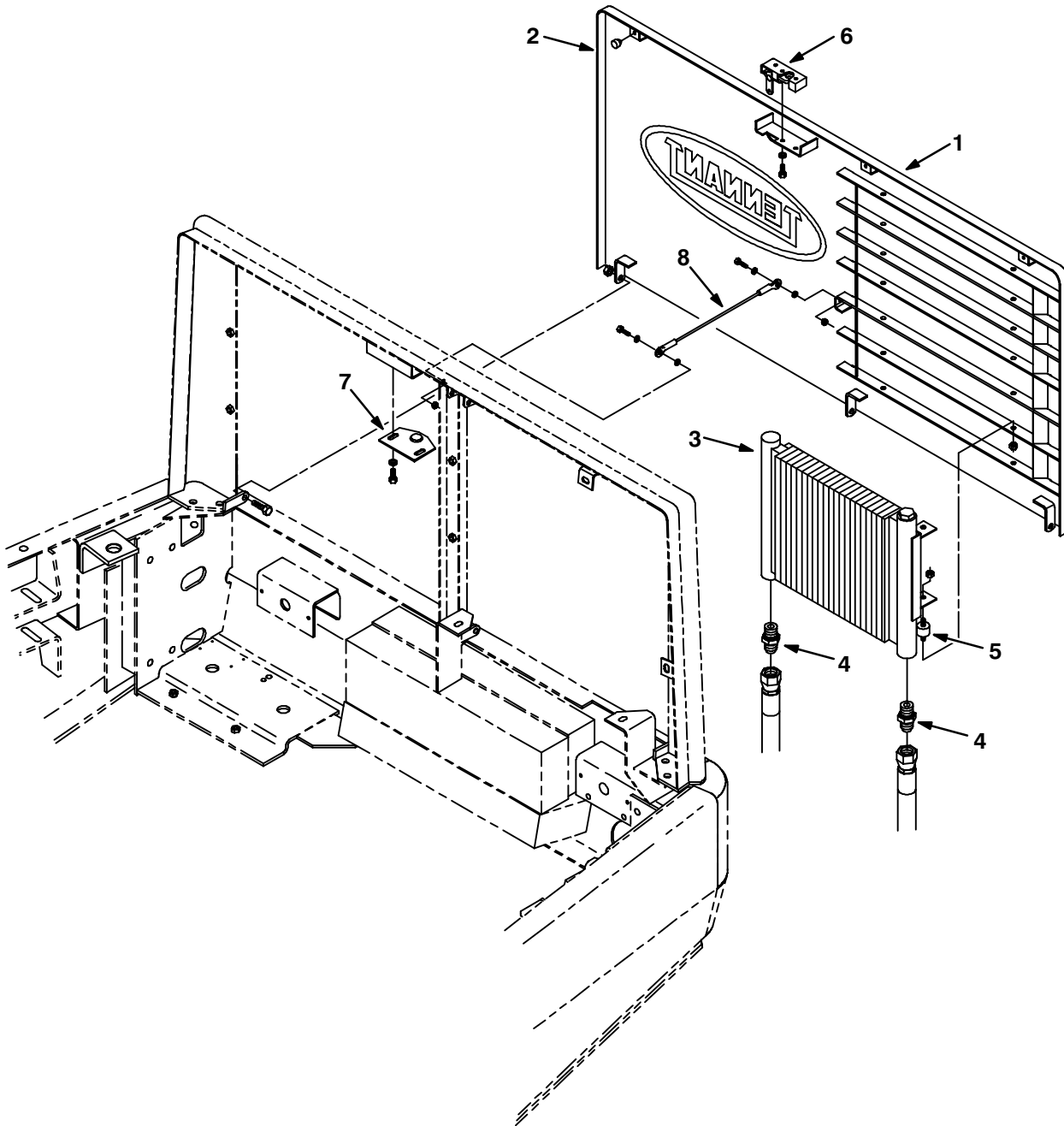

Fig. 14 – Grille and Hydraulic Cooler Group

Ref.	Tenant Part No.	Machine Serial Number	Description	Qty.
1	70552	(000000–) Door Wldt, Rear	1
2	51787	(000000–) Bumper, Rubber	3
3	64419	(000000–) Cooler–Hyd	1
4	42260	(000000–) Ftg–Hyd Str Jm12/Om12	2
5	51322	(000000–) Isolator–Vibration .31–18	4
6	59661	(000000–) Latch	1
7	65252	(000000–) Plate, Striker	1
8	36192	(000000–) Lanyard Assy.	1

Fig. 15 – Hopper Lift Arms Group

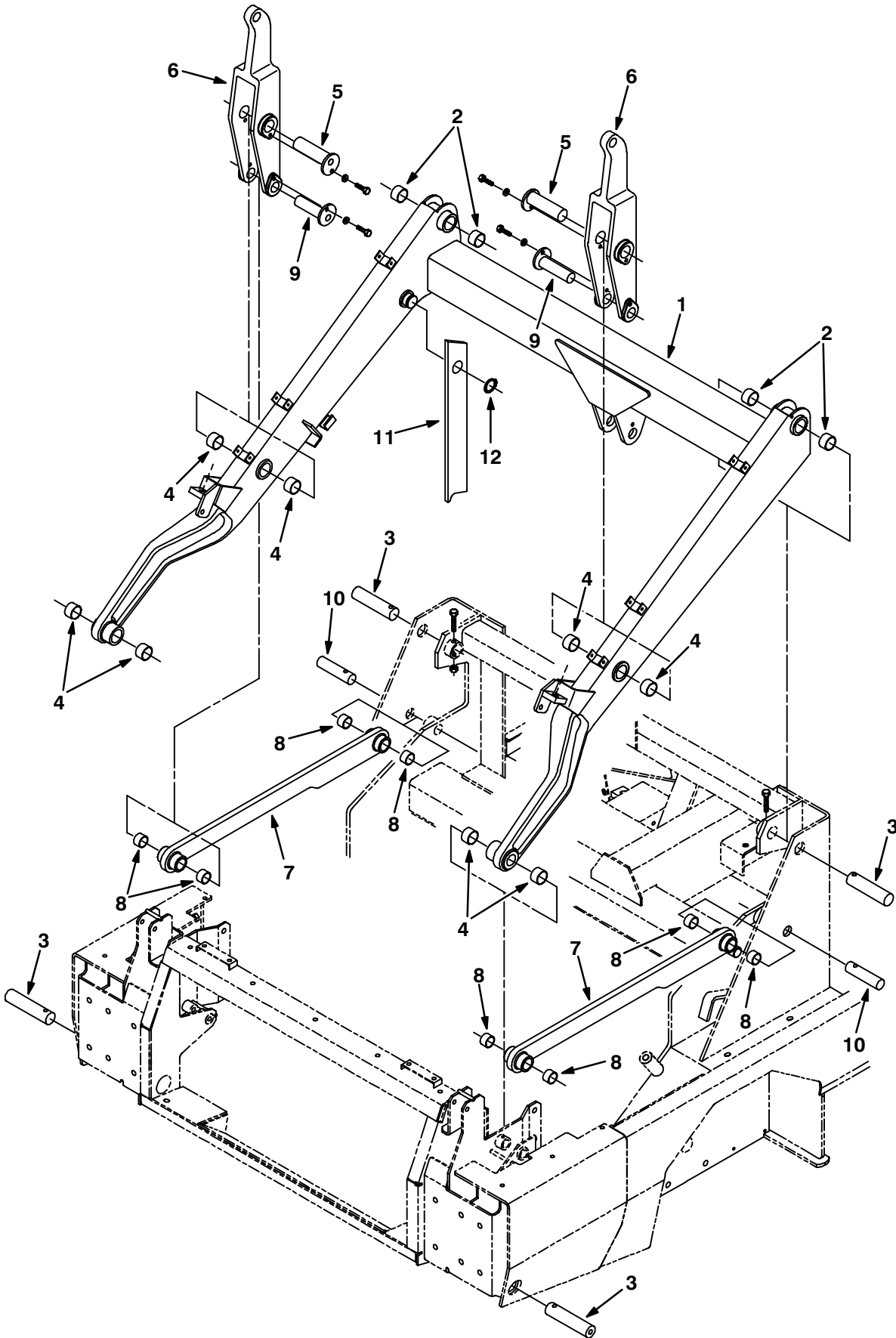

Fig. 15 – Hopper Lift Arms Group

Ref.	Tennant Part No.	Machine Serial Number	Description	Qty.
1	62996	(000000-001184)	Arm Wldt, Hopper Lift	1
2	58293	(000000-001184)	Bearng-Journal	4
3	62991	(000000-001184)	Pin, 1.500 Odx6.50, Drilled	4
4	58293	(000000-001184)	Bearng-Journal	8
5	62992	(000000-001184)	Pin Wldt, 1.500 Odx 5.00	2
6	62988	(000000-001102)	Link, Pivot, Machined	2
7	62985	(000000-001102)	Bar, Lower Arm, Machining	2
8	57936	(000000-001184)	Bearing-Journal	8
9	62993	(000000-001184)	Pin Wldt, 1.250 Od X 4.50	2
10	62990	(000000-001085)	Pin, 1.25 Odx 5.00, Drilled	2
11	63776	(000000-001184)	Arm, Safety	1
12	63926	(000000-001184)	Ring, Retaining, Ex 1.5 Dia Hd	1

Fig. 16 – Hopper Lift Arms Group

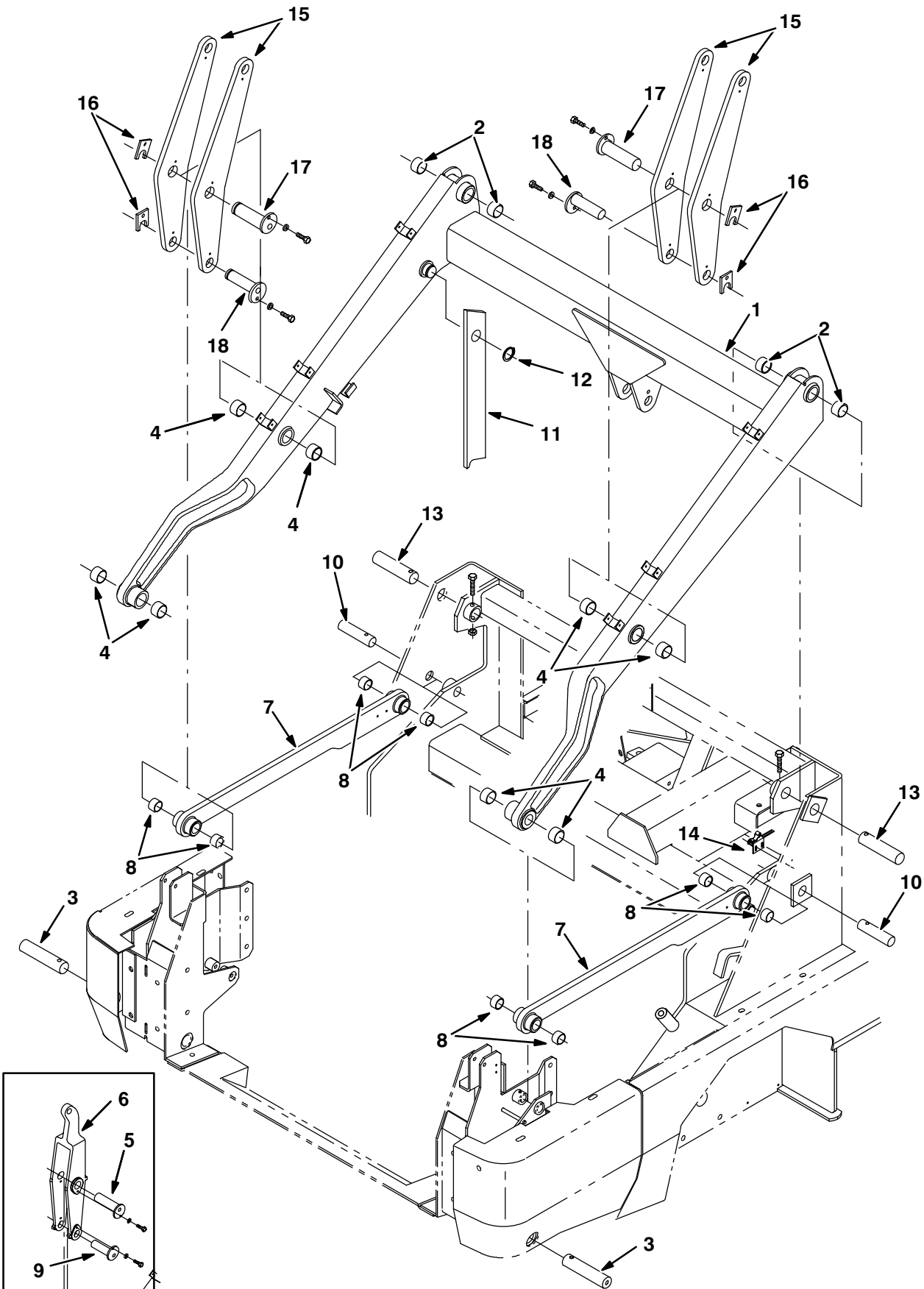

Fig. 16 – Hopper Lift Arms Group

Ref.	Tenant Part No.	Machine Serial Number	Description	Qty.
1	62996	(001185-) Arm Wldt, Hopper Lift	1
2	58293	(001185-) Bearng-Journal	4
3	77463	(001185-) Pin, 1.500 0Dx7.81, Drilled	2
4	58293	(001185-) Bearng-Journal	8
5	62992	(001185-001699) Pin, 1.500 Odx 5.00	2
6	76237	(001103-001699) Link, Pivot	2
7	76235	(001103-) Bar, Arm, Lower, Machining	2
8	57936	(001185-) Bearing-Journal	2
9	62993	(001185-001699) Pin, 1.250 Od X 4.50	2
10	76470	(001096-) Pin	2
11	63776	(001185-) Arm, Safety	1
12	63926	(001185-) Ring, Retaining, Ex 1.5 Dia Hd	1
13	76471	(001185-) Pin	2
14	59965	(001185-) Switch, Roller	1
15	83549	(001700-) Plate, Link	4
16	83554	(001700-) Plate, Pin Retainer	4
17	83551	(001700-) Pin Weldt.	2
18	83553	(001700-) Pin Weldt.	2

Fig. 17 – Hopper Lift Cylinders Group

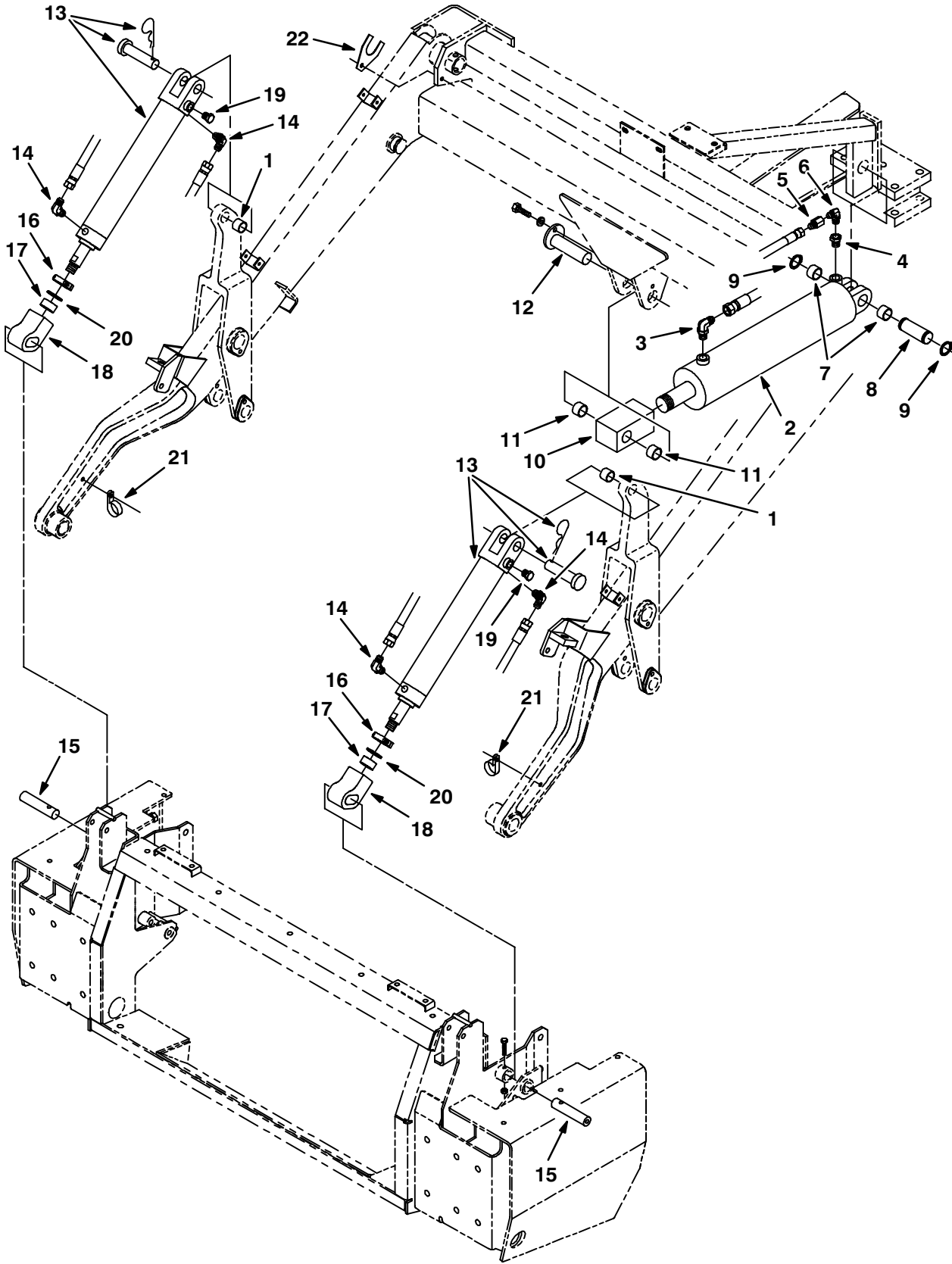

Fig. 17 – Hopper Lift Cylinders Group

Ref.	Tennant Part No.	Machine Serial Number	Description	Qty.
1	35529	(000000-001241)	Bearing, Journal	2
2	62975	(000000-001241)	Cylinder, Hyd (See Breakdowns)	1
3	47512	(000000-001241)	Ftg-Hyd E90 Jm06/Om08	1
4	55686	(000000-001241)	Ftg-Hyd Str Jm04/Om08	1
5	16456	(000000-001241)	Ftg-Hyd Rst Jm04/.063	1
6	39210	(000000-001241)	Ftg-Hyd E90 Jm04/Jf04	1
7	63585	(000000-001241)	Bearing, Journal	1
8	63583	(000000-001241)	Pin, 1.25 Odx 3.50, Grooved	1
9	58359	(000000-001241)	Retaining Ring-External, 1.25D	2
10	64156	(000000-001241)	Bar, Cylinder End	1
11	57936	(000000-001241)	Bearing-Journal	2
12	62993	(000000-001241)	Pin Wldt, 1.250 Od X 4.50	1
1036653	65223	(000000-001241)	Cylinder, Hyd (See Breakdowns)	2
14	47638	(000000-001241)	Ftg-Hyd E90 Jm04/Om06	4
15	63584	(000000-001241)	Pin, 1.00 Odx 4.50, Drilled	2
16	70459	(000000-001241)	Collar, Clamping	2
17	70523	(000000-001241)	Spacer	2
18	70514	(000000-001241)	Bar, Cylinder End	2
19	46482	(000000-001241)	Ftg-Hyd Plg Om06	2
20	73736	(000000-001241)	Washer,1.142B 1.75D .07 Lcs	2
21	67767	(000000-001241)	Clamp-Cable	2
22	75891	(000000-001241)	Shim	2

Fig. 18 – Hopper Lift Cylinders Group

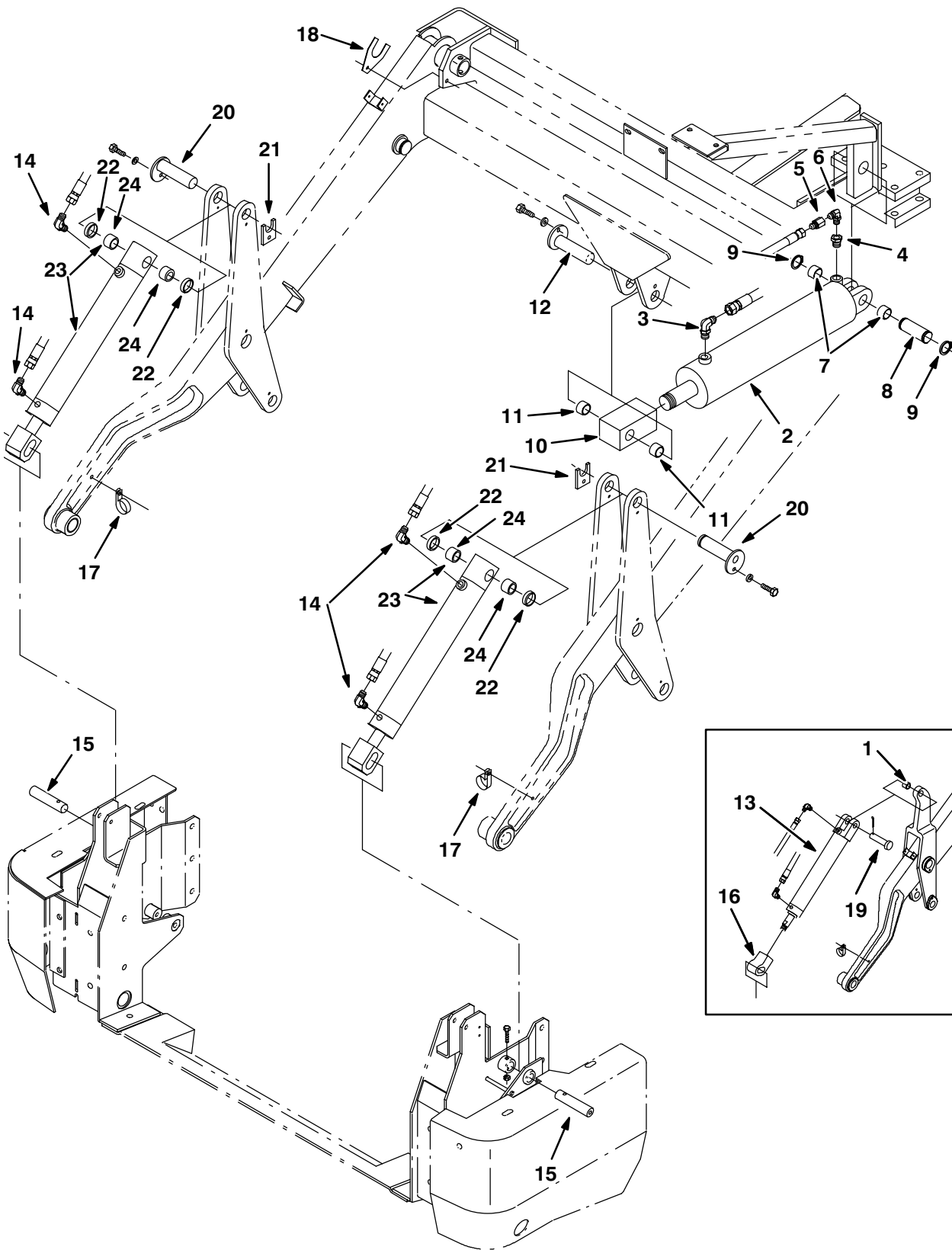

Fig. 18 – Hopper Lift Cylinders Group

Ref.	Tennant Part No.	Machine Serial Number	Description	Qty.
1	35529	(001242-001699)	Bearing, Journal	2
2	62975	(001242-)	Cylinder, Hyd 4.0B 14.5S 2500 (See Breakdowns)	1
3	47512	(001242-)	Ftg-Hyd E90 Jm06/Om08	1
4	55686	(001242-)	Ftg-Hyd Str Jm04/Om08	1
5	16456	(001242-)	Ftg-Hyd Rst Jm04/.063	1
6	39210	(001242-)	Ftg-Hyd E90 Jm04/Jf04	1
7	63585	(001242-)	Bearing, Journal	1
8	63583	(001242-)	Pin, 1.25 Odx 3.50, Grooved	1
9	58359	(001242-)	Retaining Ring-External, 1.25D	2
10	64156	(001242-)	Bar, Cylinder End	1
11	57936	(001242-)	Bearing-Journal	2
12	83553	(001242-)	Pin, 1.250 Od X 4.50	1
1036652	77780	(001242-001699)	Cylinder, Hyd 2.0B 11.6S 2500	2
14	47638	(001242-)	Ftg-Hyd E90 Jm04/Om06	4
15	63584	(001242-)	Pin, 1.00 Odx 4.50, Drilled	2
16	70514	(001242-001699)	Bar, Cylinder End	2
17	67767	(001242-)	Clamp-Cable,.69Dia. 62Wth	2
18	75891	(001242-)	Plate, Spacer	2
19	04733-4	(001242-001699)	Pin,Clevis,1.00 Dia.X 2.50 Lg	2
20	83553	(001700-)	Pin Wldt.	2
21	83554	(001700-)	Plate, Pin Retainer	2
22	83555	(001700-)	Spacer	4
∇	21304	(001700-)	Cylinder, hyd. 2.0 B 14.9S 2500	2
24	57936	(001700-)	Bearing-Journal	2

Fig. 19 – Hopper Group

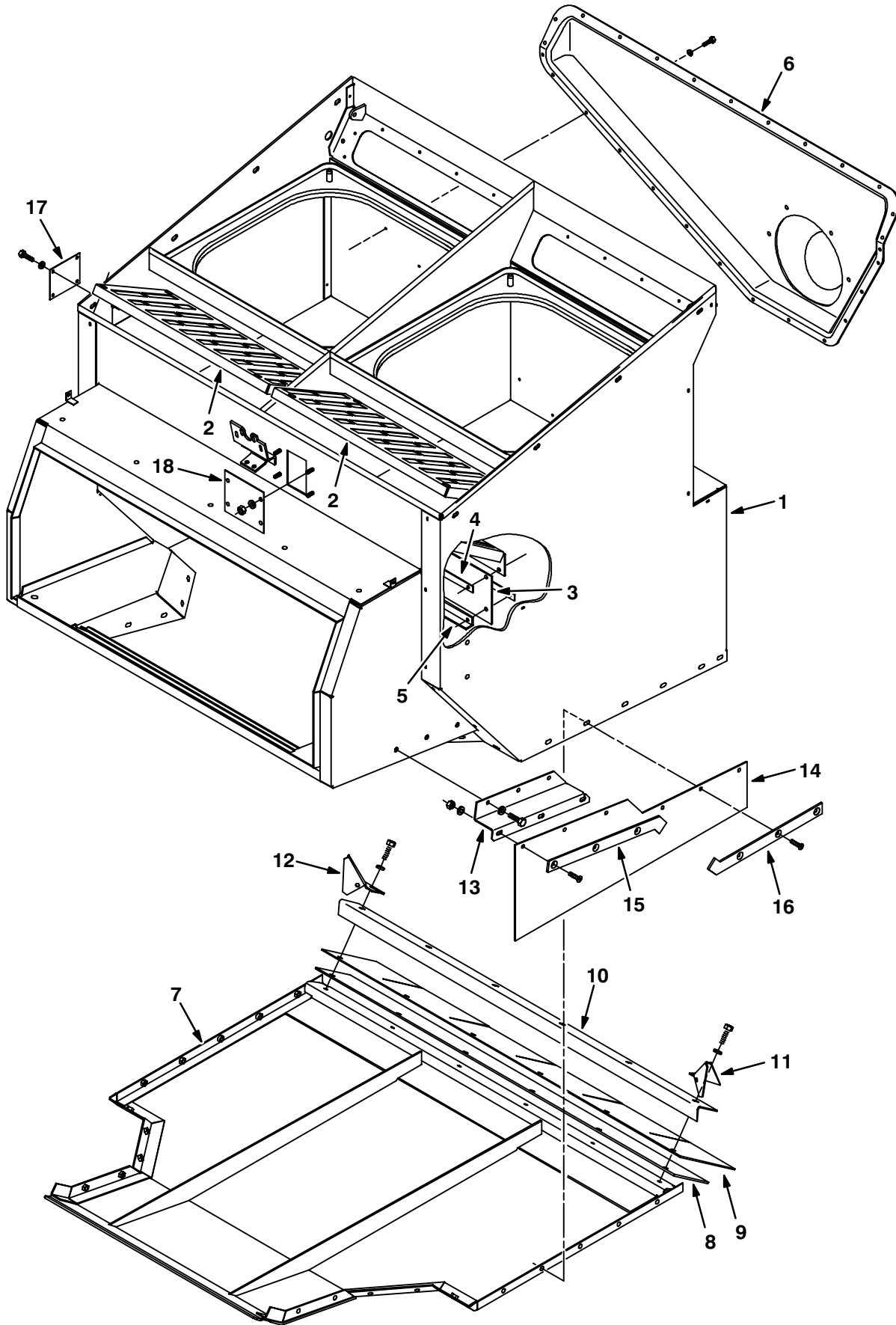

Fig. 19 – Hopper Group

Ref.	Tennant Part No.	Machine Serial Number	Description	Qty.
1	63673	(000000-001113)	Hopper Wldt	1
2	63665	(000000-001113)	Panel, Permafilter, Upper	2
3	63667	(000000-001113)	Seal, Dust	1
4	63668	(000000-001113)	Bar, Retainer, Dust Seal	1
5	63669	(000000-001113)	Angle, Dust Seal	1
6	70388	(000000-001113)	Duct, Inlet, Vac Fan	1
7	63648	(000000-001113)	Panel Wldt	1
8	73678	(000000-001113)	Skirt, Lip	1
9	73679	(000000-001113)	Skirt, Lip	1
10	63647	(000000-001113)	Angle, Retainer, Lip	1
11	74046	(000000-001113)	Panel, Deflector, Dirt, Rh	1
12	74045	(000000-001113)	Panel, Deflector, Dirt, Lh	1
13	73772	(000000-001113)	Bracket, Mtg, Skirt	1
14	73771	(000000-001113)	Skirt, Deflector	1
15	73749	(000000-001113)	Strip, Retainer, Skirt, Front	1
16	73748	(000000-001339)	Strip, Retainer, Skirt, Rear	1

Fig. 20 – Hopper Group

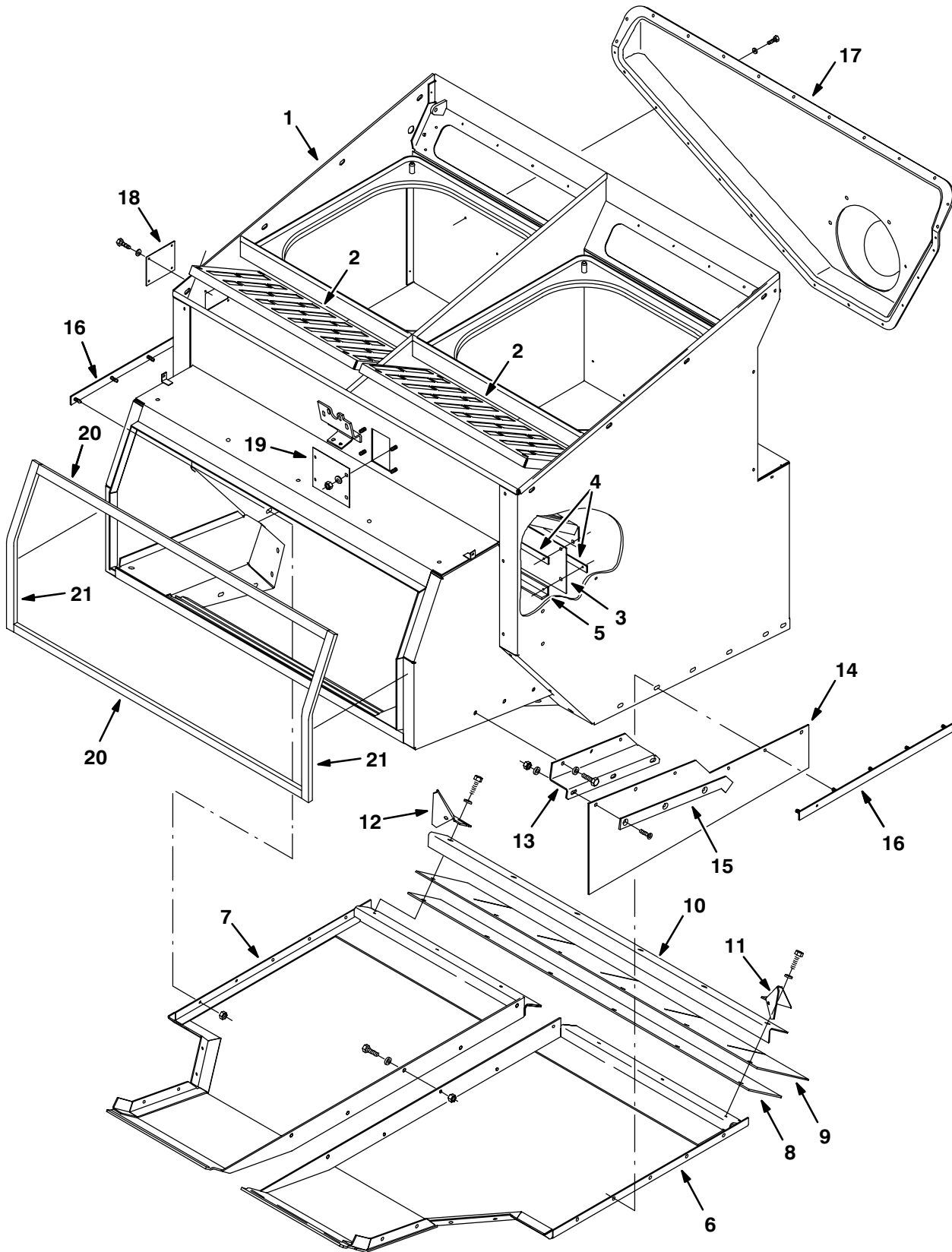

Fig. 20 – Hopper Group

Ref.	Tenant Part No.	Machine Serial Number	Description	Qty.
1	76487	(001114–) Hopper Wldt	1
2	63665	(001114–) Panel, Permafilter, Upper	2
3	63667	(001114–) Seal, Dust	1
4	63668	(001114–) Bar, Retainer, Dust Seal	2
5	63669	(001114–) Angle, Dust Seal	1
6	76474	(001114–) Panel, Hopper, Bottom, Lh	1
7	76384	(001114–) Panel, Bottom, Hopper, Rh	1
8	73678	(001114–) Skirt, Lip	1
9	73679	(001114–) Skirt, Lip	1
10	63647	(001114–) Angle, Retainer, Lip	1
11	74046	(001114–) Panel, Deflector, Dirt, Rh	1
12	74045	(001114–) Panel, Deflector, Dirt, Lh	1
13	73772	(001114–) Bracket, Mtg, Skirt	1
14	73771	(001114–) Skirt, Deflector	1
15	73749	(001114–) Strip, Retainer, Skirt, Front	1
16	79139	(001340–) Strip, Hopper	2
17	70388	(001114–) Duct, Inlet, Vac Fan	1
18	74069	(001114–) Plate, Cover	1
19	73887	(001114–) Plate, Cover	1
20	79597	(001114–) Seal, Foam, Urethane Covered	2
21	79600	(001114–) Seal, Foam, Urethane Covered	2

Fig. 21 – Hopper Door Group

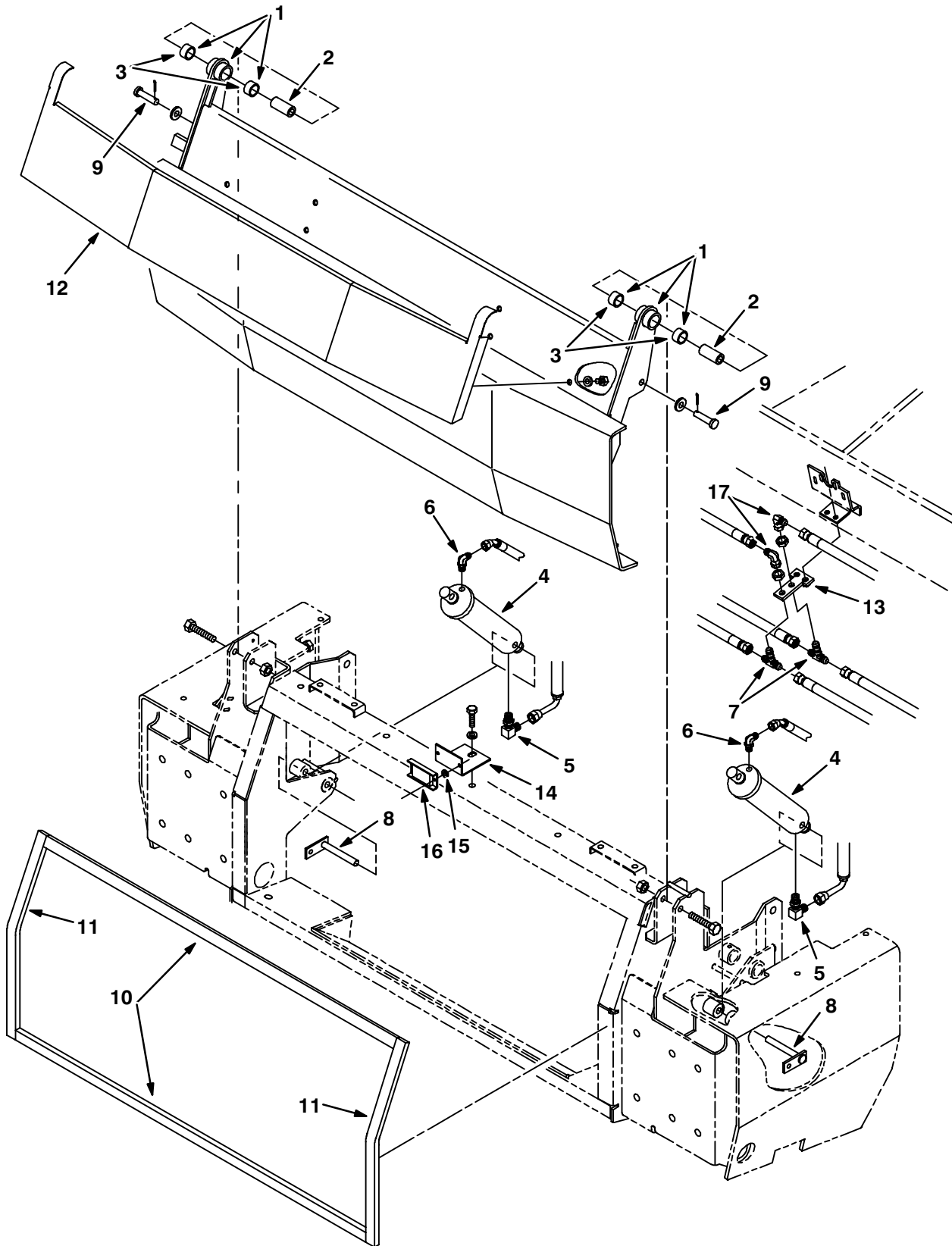

Fig. 21 – Hopper Door Group

Ref.	Tenant Part No.	Machine Serial Number	Description	Qty.
1	64232	(000000-001130)	Door Wldt, Hopper	1
2	65302	(000000-001130)	Sleeve, .531B .99D1 .75 Stl	2
3	35688	(000000-001130)	Bearing, Journal	4
4	63589	(000000-001130)	Cylinder, Hyd	2
5	77097	(000000-001130)	Ftg-Hyd E90 Jm04/Om04	2
6	82825	(000000-001130)	Ftg-Hyd E90 Jm04/Om04	2
7	34392	(000000-001130)	Ftg-Hyd Tee Jm04Jmjim	2
8	64893	(000000-001130)	Pin	2
9	11211	(000000-001130)	Pin, Clevis .50 Dia X 2.25 Lg	2
10	70854	(000000-001130)	Seal, Urethane	2
11	70855	(000000-001130)	Seal, Urethane	2
12	65287	(000000-001130)	Panel, Hopper Door	1
13	75012	(000000-001130)	Bracket, Mtg, Ftg	1
14	75852	(000000-001130)	Bracket, L	1
15	63416	(000000-001130)	Washer, .310B .88D .12Rbr	2
16	63378	(000000-001130)	Magnet	1
17	39210	(001055-001130)	Ftg-Hyd E90 Jm04/Jf04	2

Fig. 22 – Hopper Door Group

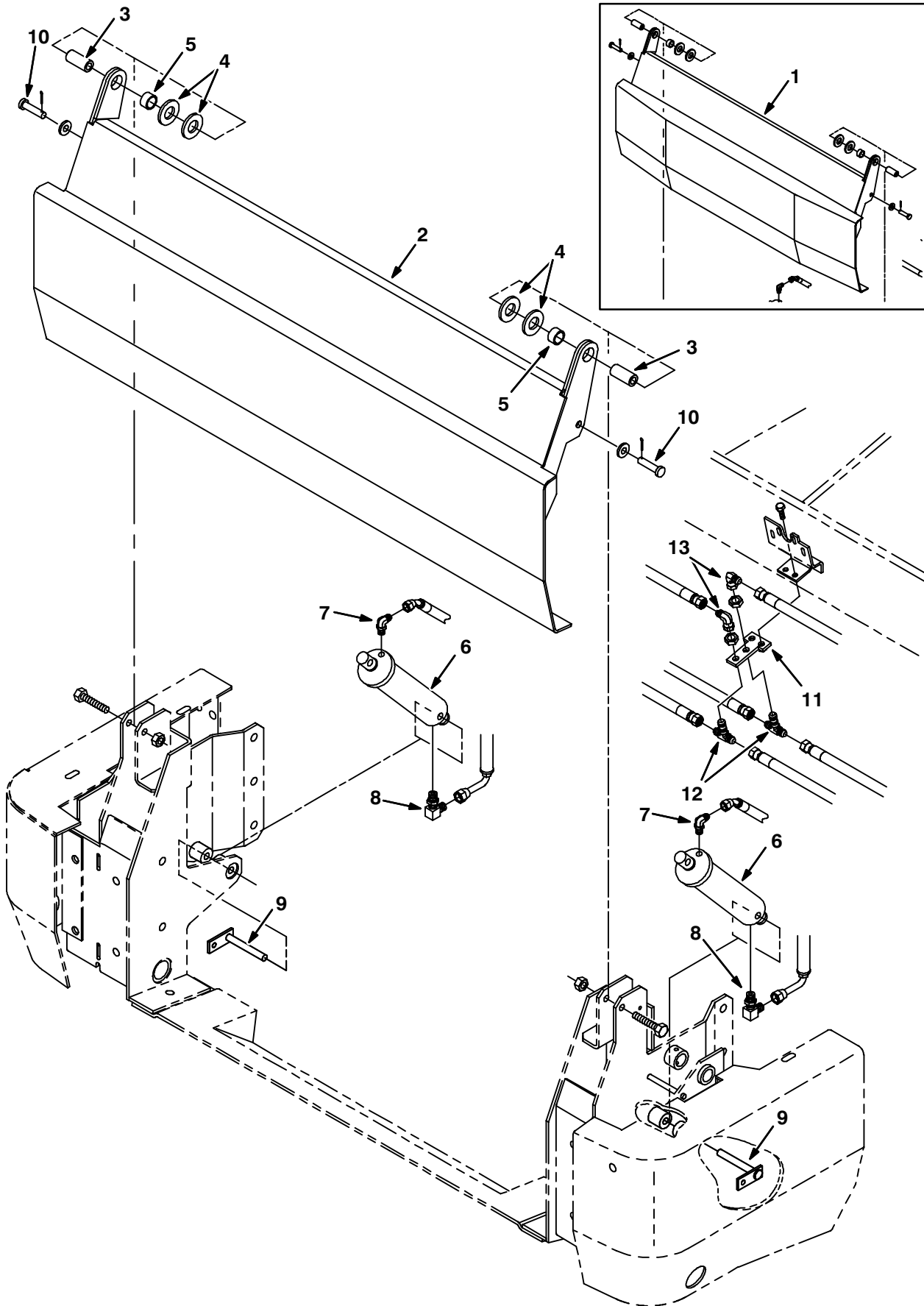

Fig. 22 – Hopper Door Group

Ref.	Tennant Part No.	Machine Serial Number	Description	Qty.
1	76936	(001131-001258)	Door Wldt, Hopper	1
2	76529	(001259-001699)	Door Wldt, Hopper	1
2	83618	(001700-)	Door Wldt, Hopper	1
3	79138	(001131-)	Sleeve, Pivot, Door	2
4	79596	(001131-)	Washer, 1.015B 1.75D .11Hrs	4
5	35688	(001131-)	Bearing, Journal	2
6	21721	(001131-)	Cylinder, Hyd 2.0B 8.0S 2500	2
7	82825	(001131-)	Ftg-Hyd E90 Jm04/Om04	2
8	77097	(001131-)	Ftg-Hyd E90 Jm04/Om04	2
9	64893	(001131-)	Pin	2
10	21722	(001131-)	Pin, Clevis .50 Dia X 2.25 Lg	2
11	75012	(001131-)	Bracket, Mtg, Ftg	1
12	34392	(001131-)	Ftg-Hyd Tee Jm04/Jmjm	2
13	39210	(001131 -)	Ftg-Hyd E90 Jm04/Jf04	2

Fig. 23 – Hopper Cover Group

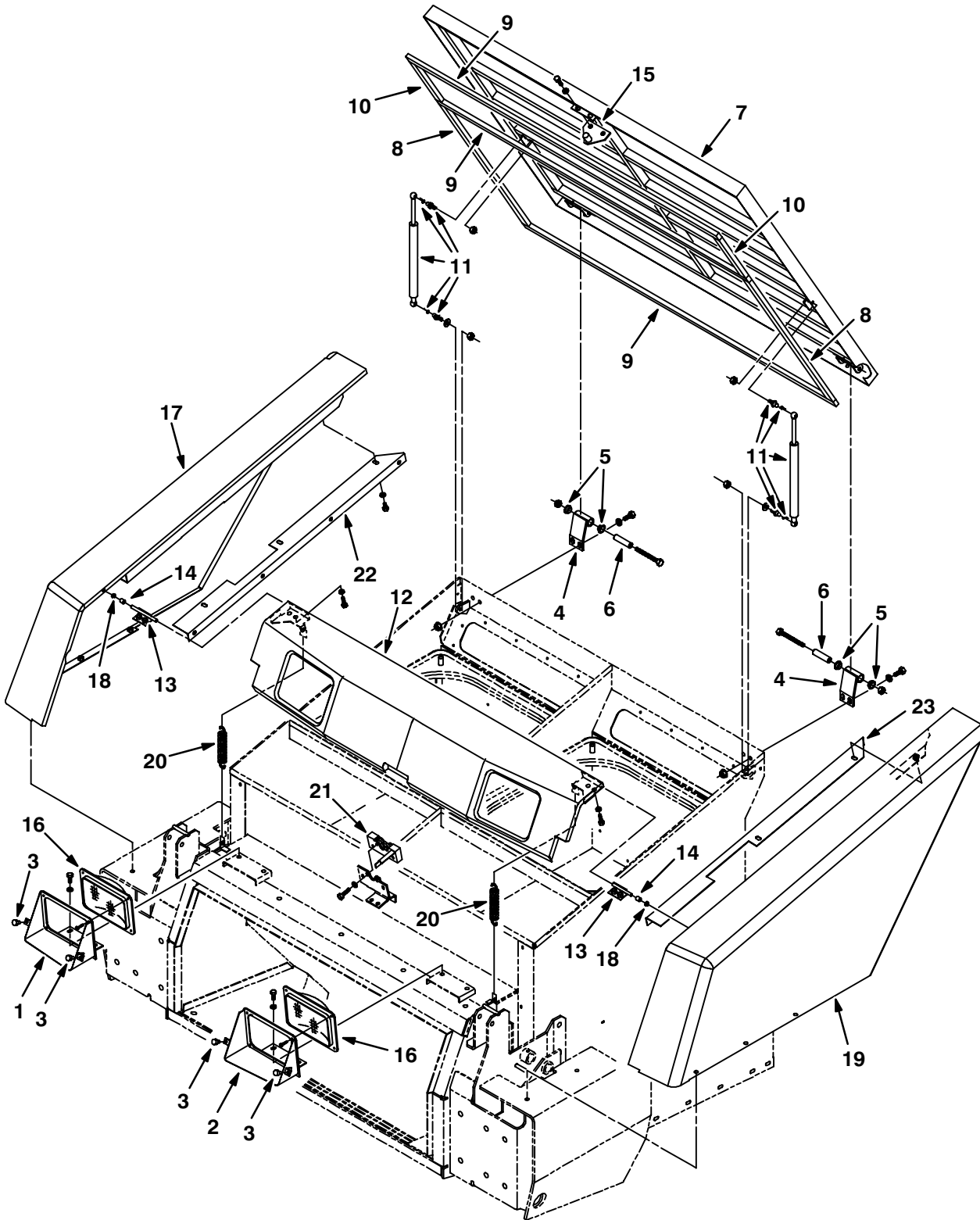

Fig. 23 – Hopper Cover Group

Ref.	Tenant Part No.	Machine Serial Number	Description	Qty.
1	65290	(000000-001130)	Bracket Wldt, Mtg,Headlamp,Rh (Replaced by 77388)	1
2	70472	(000000-001130)	Bracket Wldt, Mtg,Headlamp,Lh (Replaced by 77388)	1
3	51787	(000000-001211)	Bumper, Rubber	4
4	70762	(000000-001211)	Hinge Wldt	2
5	04843	(000000-001211)	Bearing, Flange .625 Bore	4
6	70761	(000000-001211)	Tube, 0.62D .44B 2.44,Stl	2
7	70595	(000000-001211)	Cover Assy, Hopper	1
8	70851	(000000-001211)	Seal, Urethane	3
9	70852	(000000-001211)	Seal, Urethane	2
10	70853	(000000-001211)	Seal, Urethane	2
11	69906	(000000-001211)	Spring-Gas Assy	2
12	65285	(000000-001130)	Panel Wldt, Headlight	1
13	70730	(000000-001211)	Hinge Wldt	2
14	74015	(000000-001211)	Sleeve, .320B .32D .49 Lc Stl	2
15	70742	(000000-001211)	Pin Wldt, Latch	1
16	58524	(000000-001211)	Headlight, 12V.Rect.	2
17	65278	(000000-001211)	Panel Wldt, Fender, Rh	1
18	11747	(000000-001211)	Bearing, Nylon	2
19	65281	(000000-001211)	Panel Wldt, Fender, Lh	1
20	01274	(000000-001211)	Sprng,Tens,0.965Odx.09Wire4.4L	2
21	59195	(000000-001211)	Latch, Hook, Rh	1
22	75047	(000000-001211)	Bracket, R. H.	1
23	75046	(000000-001211)	Bracket, L. H.	1

Fig. 24 – Hopper Cover Group

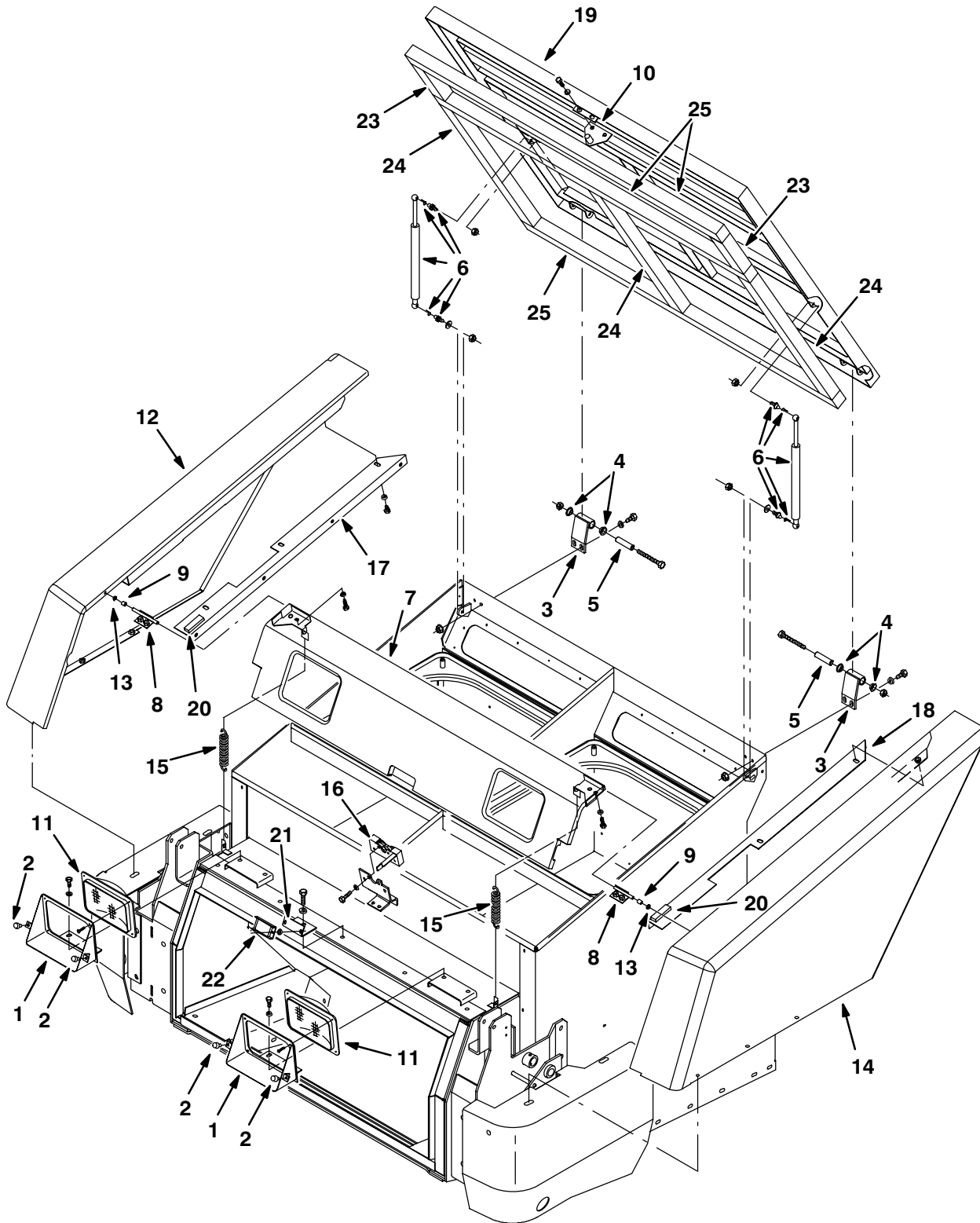

Fig. 24 – Hopper Cover Group

Ref.	Tennant Part No.	Machine Serial Number	Description	Qty.
1	77388	(001131–)	Bracket, Mounting, Headlamp	2
2	51787	(001212–)	Bumper, Rubber	4
3	70762	(001212–)	Hinge	2
4	04843	(001212–)	Bearing, Flange .625 Bore	4
5	70761	(001212–)	Tube, 0.62D .44B 2.44, Stl	2
6	69906	(001212–)	Spring–Gas, Engine Cover	2
7	77394	(001131–)	Panel, Headlight	1
8	70730	(001212–)	Hinge	2
9	74015	(001212–)	Sleeve, .320B .32D .49 Lc Stl	2
10	70742	(001212–)	Pin Wldt, Latch	1
11	58524	(001212–)	Headlight, 12V.Rect.	2
12	65278	(001212–)	Panel Wldt, Fender, Rh	1
13	11747	(001212–)	Bearing, Nylon	2
14	65281	(001212–)	Panel Wldt, Fender, Lh	1
15	01274	(001212–)	Sprng,Tens,0.965Odx.09Wire4.4L	2
16	79019	(001212–)	Latch, Hook, Rh, Single Catch	1
17	75047	(001212–)	Bracket, Rh	1
18	75046	(001212–)	Bracket, Lh	1
19	79587	(001212–001383)	Cover Assy, Hopper	1
19	21221	(001384–)	Cover Assy, Hopper	1
20	79591	(001212–)	Bumper, Cover, Hopper	2
21	77400	(001131–)	Angle, Mount	1
22	63378	(001212–)	Magnet, Drive Brush	1
23	77390	(001212–)	Seal, Urethane Covered Foam	2
24	77391	(001212–)	Seal, Urethane Covered Foam	3
25	77392	(001212–)	Seal, Urethane Covered Foam	3

Fig. 25 – Hopper Bumper Group

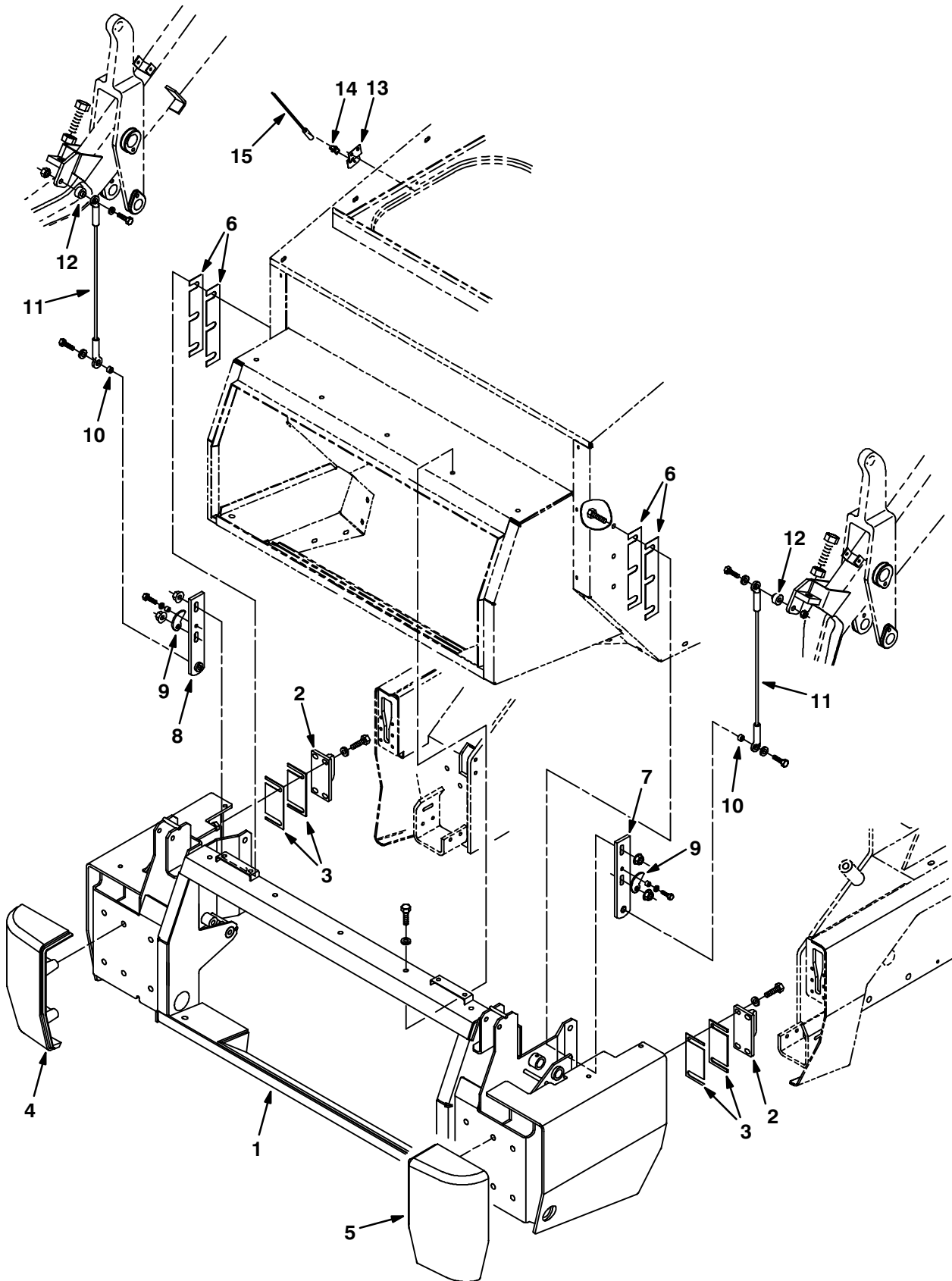

Fig. 25 – Hopper Bumper Group

Ref.	Tenant Part No.	Machine Serial Number	Description	Qty.
1	63632	(000000-001184)	Bumper Wldt, Front	1
2	63671	(000000-001184)	Latch, Bumper	2
3	63662	(000000-001184)	Plate, Shim, Bumper, .06 Thk	4
4	63676	(000000-001184)	Bumper, Front, Machining, Rh	1
5	63677	(000000-001184)	Bumper, Front, Machining, Lh	1
6	74070	(000000-001184)	Plate, Shim, Hopper	4
7	74867	(000000-001102)	Plate Wldt, Link, Lh	1
8	74868	(000000-001102)	Plate Wldt, Link, Rh	1
9	75667	(000000-001102)	Cam, Adjuster	2
10	40282	(000000-001102)	Sleeve, .370B .50D .38 Cd.Znc	2
11	70532	(000000-001102)	Cable, Retaining	2
12	70528	(000000-001102)	Spacer	2
13	75827	(000000-001102)	Bracket, Mtg, Switch	1
14	40131	(000000-001102)	Clip, Mercury Switch	1
15	75843	(000000-001102)	Switch Assy, Hopper, Angle	1

Fig. 26 – Hopper Bumper Group

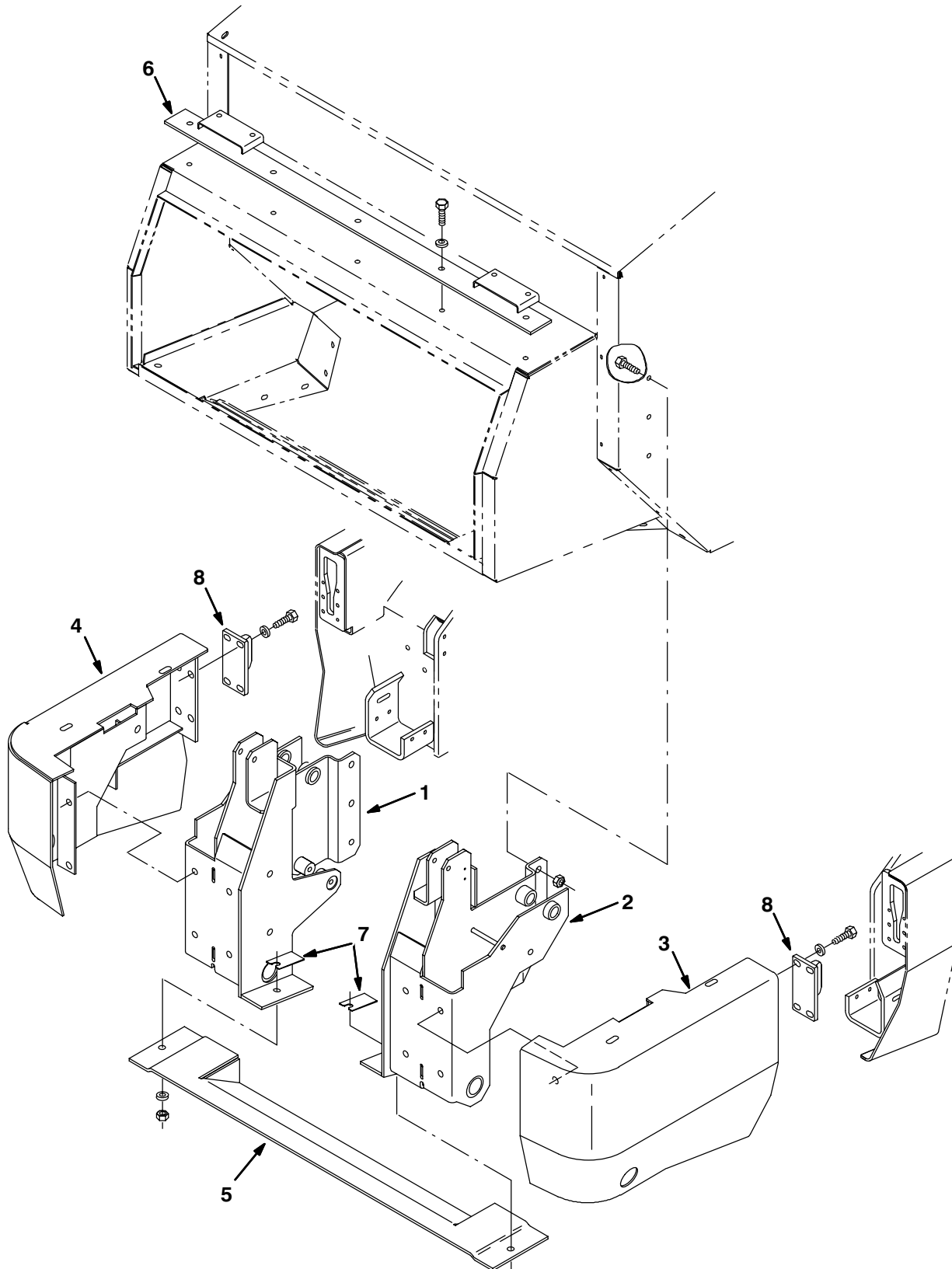

Fig. 26 – Hopper Bumper Group

Ref.	Tenant Part No.	Machine Serial Number	Description	Qty.
1	76895	(001185-001699)	Bumper Wldt, Front, Rh	1
1	83547	(001700-)	Bumper Wldt, Sppt, Hopper, Rh	1
2	77479	(001185-001699)	Support Wldt, Hopper Lh	1
2	83548	(001700-)	Support Wldt, Sppt, Hopper Lh	1
3	77482	(001185-001699)	Bumper Wldt, Lh	1
3	83620	(001700-)	Bumper Wldt, Lh	1
4	76871	(001185-001699)	Bumper Wldt, Rh	1
4	83622	(001700-)	Bumper Wldt, Rh	1
5	77523	(001185-)	Guard Wldt, Hopper	1
6	77516	(001185-)	Bracket Wldt, Mtg, Headlight	1
7	79181	(001185-)	Shim	2
8	63671	(001185-)	Latch, Bumper	2

Fig. 27 – Filter Shaker Group

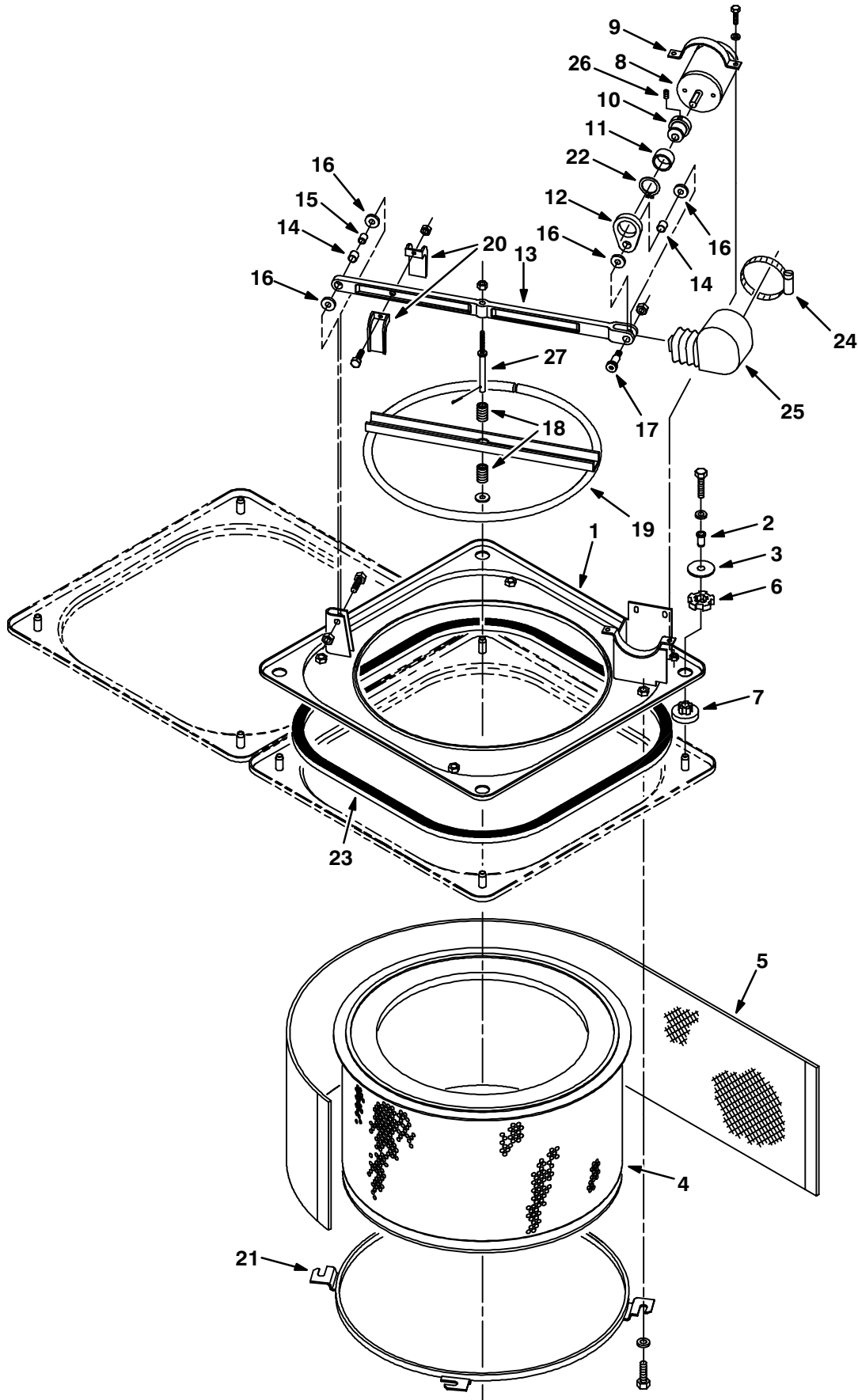

Fig. 27 – Filter Shaker Group

Ref.	Tennant Part No.	Machine Serial Number	Description	Qty.
1	64580	(000000–)	Panel Wldt, Shaker	2
2	64874	(000000–)	Ferrule	8
3	64873	(000000–)	Disc	8
▽ 4	63297	(000000–)	Filter Assy	2
△ 5	63311	(000000–)	Screen, Filter	1
6	64618	(000000–)	Ring, Isolator, Outer, Rbr	8
7	64621	(000000–)	Bushing, Isolator	8
8	31999	(000000–)	Motor, Electric, 13.6 Vdc	2
9	64559	(000000–)	Clamp, Mtg, Motor, Upper	2
10	64567	(000000–)	Shaft, Eccentric	2
11	32006	(000000–)	Bearing	2
12	64394	(000000–)	Link, Eccentric	2
▽ 13	77471	(000000–)	Shaker Bar Replacement Kit	2
△ 14	63233	(000000–)	Bearing, Fiberglide .50 X .50	2
△ 15	63234	(000000–)	Sleeve, Bearing	1
△ 16	59633	(000000–)	Bearing, Thrust – Fiberglide	4
△ 17	58357	(000000–)	Shoulder Screw	2
18	64392	(000000–)	Spring	4
19	64501	(000000–)	Ring Wldt, Shaker	2
20	64410	(000000–)	Guide	4
21	64500	(000000–)	Ring Wldt, Mtg, Filter	2
22	70651	(000000–)	Ring, Retaining, Ext 1.12	2
23	21303	(000000–)	Seal Kit, Shaker Panel	2
24	43555	(000000–)	Clamp–Wormdrive, 1.62– 3.50D	2
25	73734	(000000–)	Seal, Dust	2
26	70650	(000000–)	Set Screw	2
27	32009	(000000–)	Bar, Shaker Stem	2

Fig. 28 – Pressure Switch Group

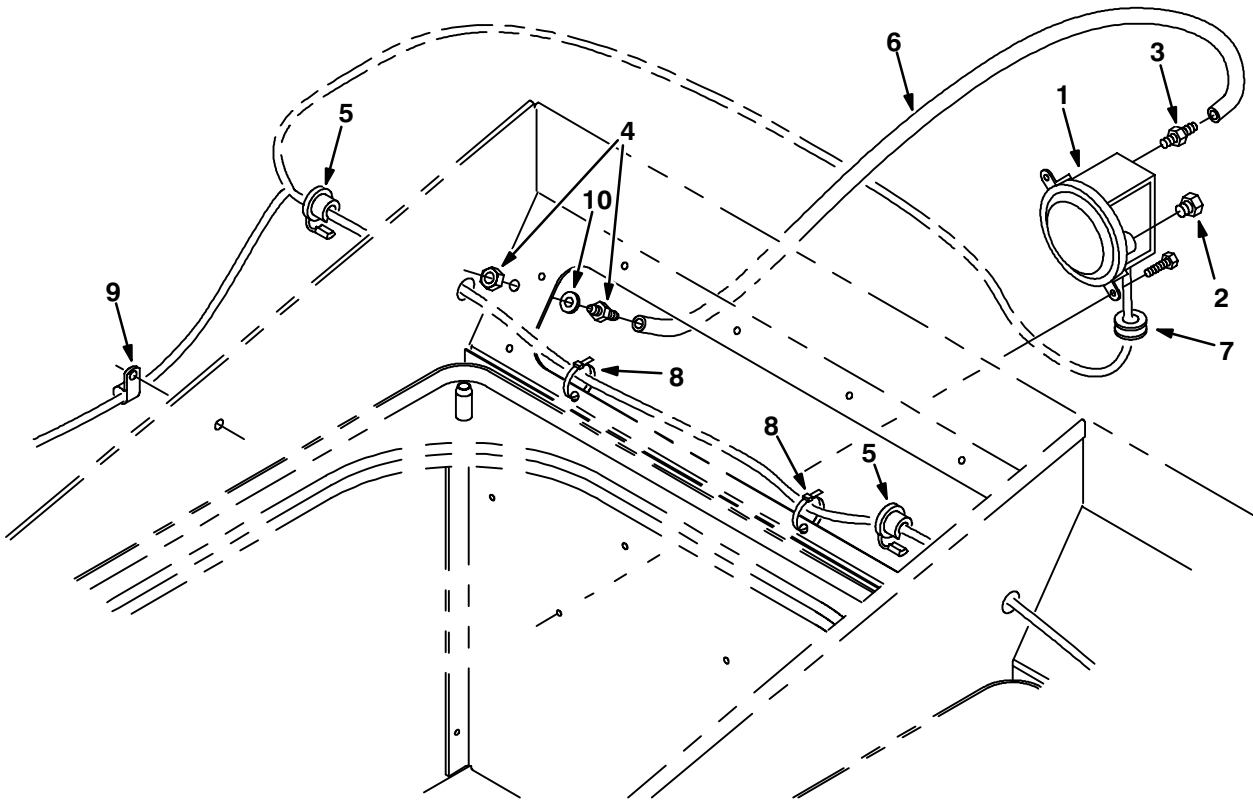

Fig. 28 – Pressure Switch Group

Ref.	Tenant Part No.	Machine Serial Number	Description	Qty.
1	75465	(000000–) Switch, Pressure	1
2	82739	(000000–) Ftg, Breather	1
3	40607	(000000–) Ftg–Brs Str Bm03/Pm02	1
4	39923	(000000–) Ftg,Bulkhead–Barb Wh 1074X4	1
5	34864	(000000–) Strain,Relief	2
6	73727	(000000–) Hose, Vac, Rubber	1
7	10632–4	(000000–) Grommet,Rbr,0.62Id,For .06Matl	1
8	49266	(000000–) Tie, Cable 1.75D Max 7.50Lg	4
9	26395–1	(000000–) Clamp–Cable, 0.56Dia 0.38Wth	2
10	43454	(000000–) Washer	1

Fig. 29 – Engine and Alternator Group

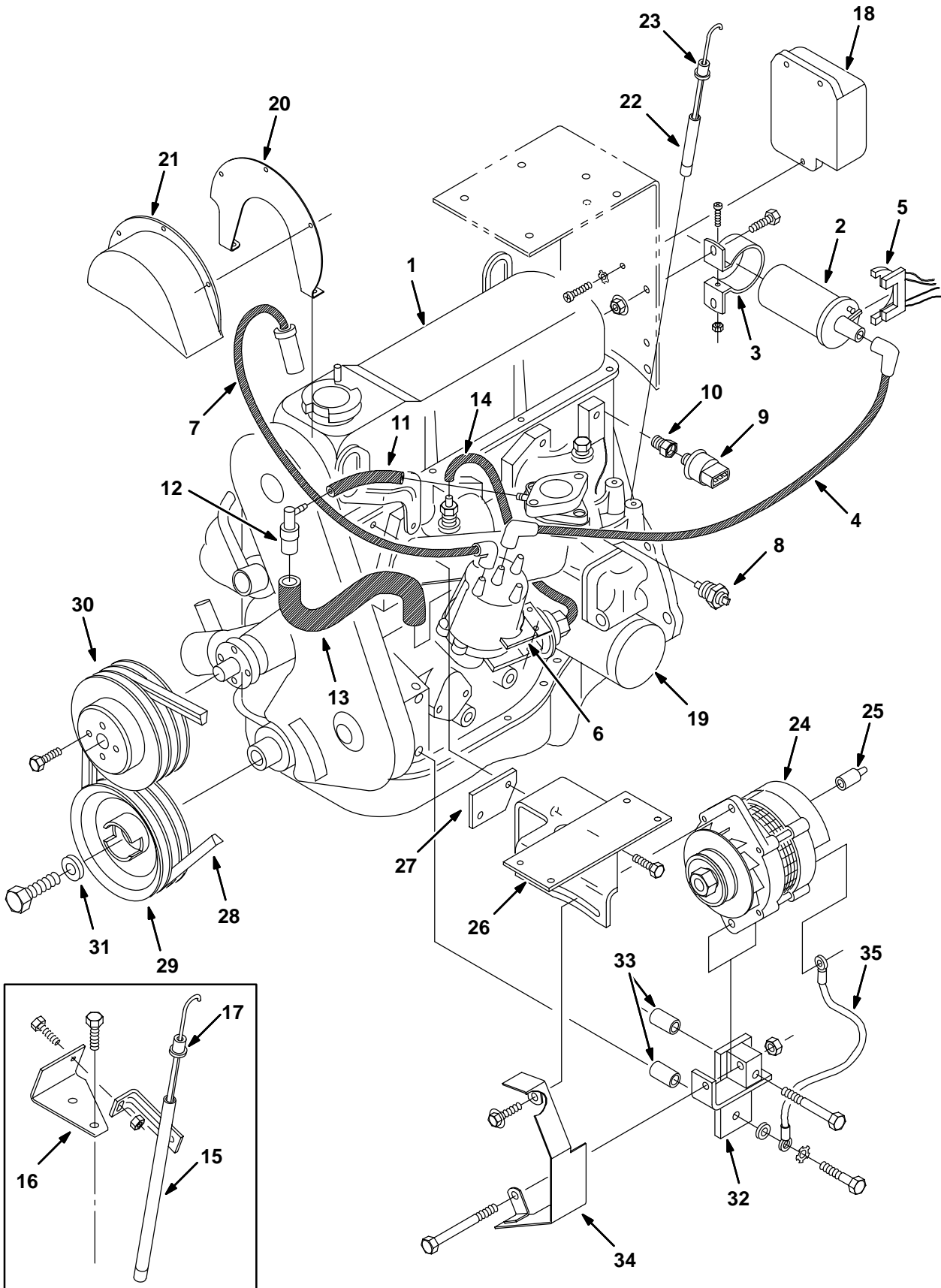

Fig. 29 – Engine and Alternator Group

Ref.	Tennant Part No.	Machine Serial Number	Description	Qty.
1	61854	(000000–001699)	Engine Assy, Lsg423 W/Label (See Engine Breakdown)	1
2	36012	(000000–001699)	Coil Ignition	1
3	54911–30	(000000–001699)	Strap, Coil	1
4	36011	(000000–001699)	Wire, Ing Coil, Suppressor	1
5	61871	(000000–001699)	Wiring Assy	1
6	36008	(000000–001699)	Shield, Distributor	1
7	36037	(000000–001699)	Wire Assy, Spark Plug (Set of Four)	1
8	36165	(000000–001699)	Send Unit, Temperature	1
9	79399	(000000–001699)	Switch, Pressure, Oil	1
10	17414	(000000–001699)	Ftg–Hyd Str Pm04/Pf02	1
11	35992	(000000–001699)	Hose, Pcv	1
12	35993	(000000–001699)	Valve, Pcv	1
13	36032	(000000–001699)	Hose, Pcv	1
14	19774	(000000–001699)	Hose, Vacuum .16 Id X 15.0 Lg	1
15	36046	(000000–xxxxxx)	Tube, Dipstick	1
16	35983	(000000–xxxxxx)	Bracket, Dipstick Tube	1
17	36045	(000000–xxxxxx)	Dipstick	1
18	36006	(000000–001699)	Module, Ignition	1
19	39703–2	(000000–001699)	Filter Element, Oil, Cont. Gas SE	1
20	21295	(000000–001699)	Plate, Backing	1
21	21294	(000000–001699)	Cover	1
22	10724	(xxxxxx–001699)	Tube, Dipstick	1
23	10723	(xxxxxx–001699)	Dipstick	1
∇ 24	60559	(000000–001699)	Alternator, 50A/12V Mando	1
	61931	(000000–001699)	Regulator	1
	86041	(000000–001699)	Bearing,Ball.669B 1.575D .472W	1
	61529	(000000–001699)	Brush Kit	1
	61531	(000000–001699)	Rectifier	1
	70160	(000000–001699)	Pulley, Alternator	1
25	61363	(000000–001699)	Boot, Alternator	2
26	70387	(000000–001699)	Bracket Weldt, Alternator, Top	1
27	36085	(000000–001699)	Spacer, Alternator Arm	1
28	60714	(000000–001699)	Belt–V, .47, 42.50Lg	1
29	36015	(000000–001699)	Sheave, Crankshaft	1
30	36014	(000000–001699)	Sheave, Water Pump	1
31	35753	(000000–001699)	Washer–Flt 15.0 X 37.0 X 5.5 M15	1
32	64037	(000000–001699)	Bracket Wldt., Mtg., Alternator	1
33	43609	(000000–001699)	Sleeve, .500B .69D1.281 Cr. Cad	2
34	74076	(000000–001699)	Guard Wldt.	1
35	82731	(001032–001699)	Wire, Ground, Alternator	1

Fig. 30 – Engine and Alternator Group

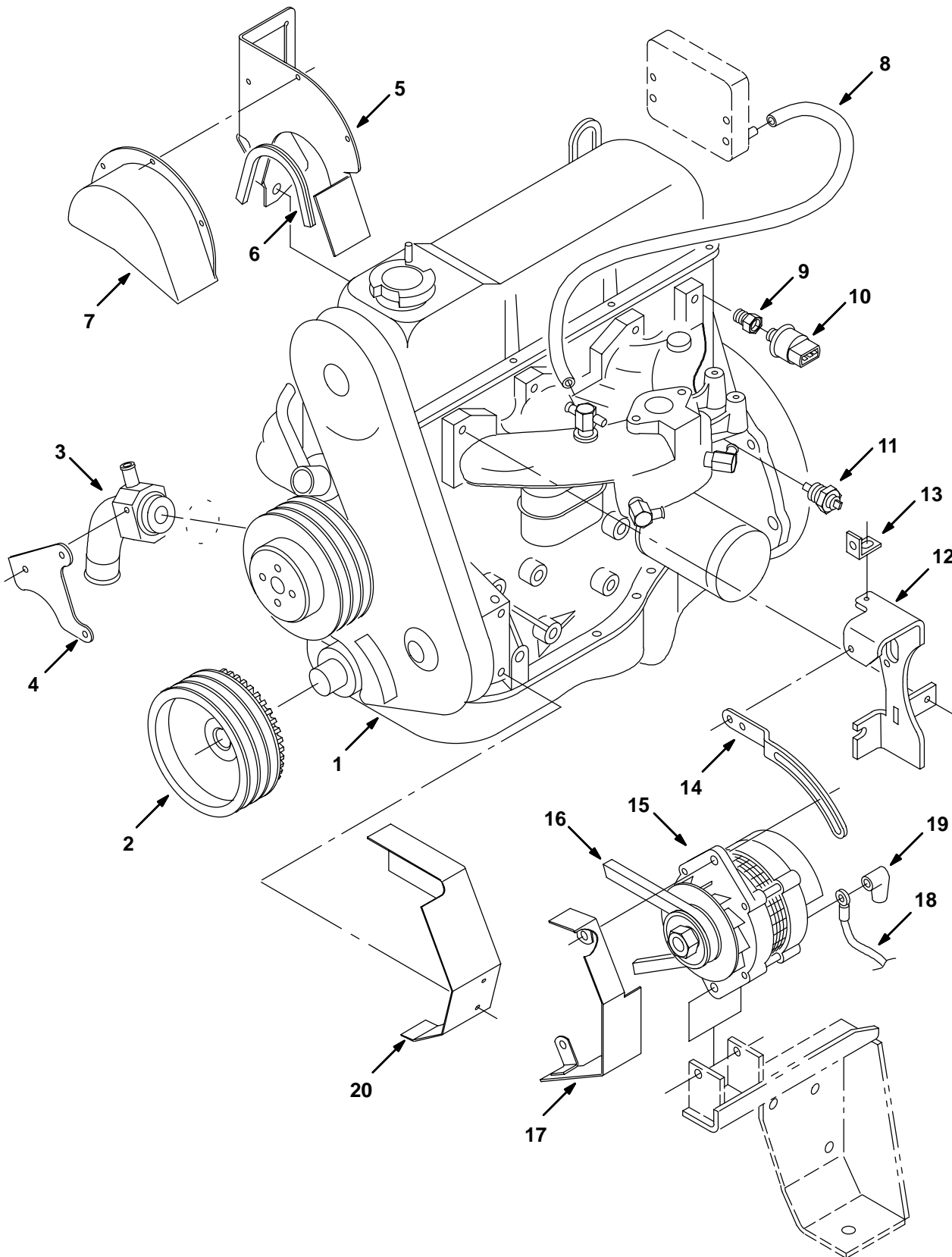

Fig. 30 – Engine and Alternator Group

Ref.	Tenant Part No.	Machine Serial Number	Description	Qty.
1	83652	(001700–) Engine Purch Kit, 800 Lrg423Fd	1
2	83664	(001700–) Sheave, Eng Crank,Fd W/Tg 2Gr	1
3	83729	(001700–) Adaptor, Water Pump Machined	1
4	83731	(001700–) Plate, Mounting, Water Pump	1
5	83768	(001700–) Bracket, Mtg, Coil	1
6	59375	(001700–) Extrusion,.062 Matl10.10Lg	1
7	21294	(001700–) Cover	1
8	19774	(001700–) Hose, Vacuum,.16ld X 15.0 Lg	1
9	17414	(001700–) Ftg–Hyd Str Pm04/Pf02	1
10	79399	(001700–) Switch, Pressure Oil	1
11	36165	(001700–) Send Unit, Temperature	1
12	83750	(001700–) Bracket Wldt, Alternator Mtg	1
13	31038	(001700–) Brkt–L,1.2 1.0 .12 .8L2/H&S	1
14	31526	(001700–) Arm Alternator	1
∇ 15	60559	(001700–) Alternator, 50A/12V Mando	1
	61931	(001700–) Regulator	1
	86041	(001700–) Bearing,Ball.669B 1.575D .472W	1
	61529	(001700–) Brush Kit	1
	61531	(001700–) Rectifier	1
	70160	(001700–) Pulley, Alternator	1
16	83692	(001700–) Belt, V, Hc 38–46.375	1
17	74076	(001700–) Guard	1
18	82731	(001700–) Wire–Ground, Alternator	1
19	34065	(001700–) Boot, Packard Electric (Altern	3
	61363	(001700–) Boot, Str .42ID .12H .25L	2
20	83853	(001700–) Cover Weldt.	1

Fig. 31 – Engine Mount Group

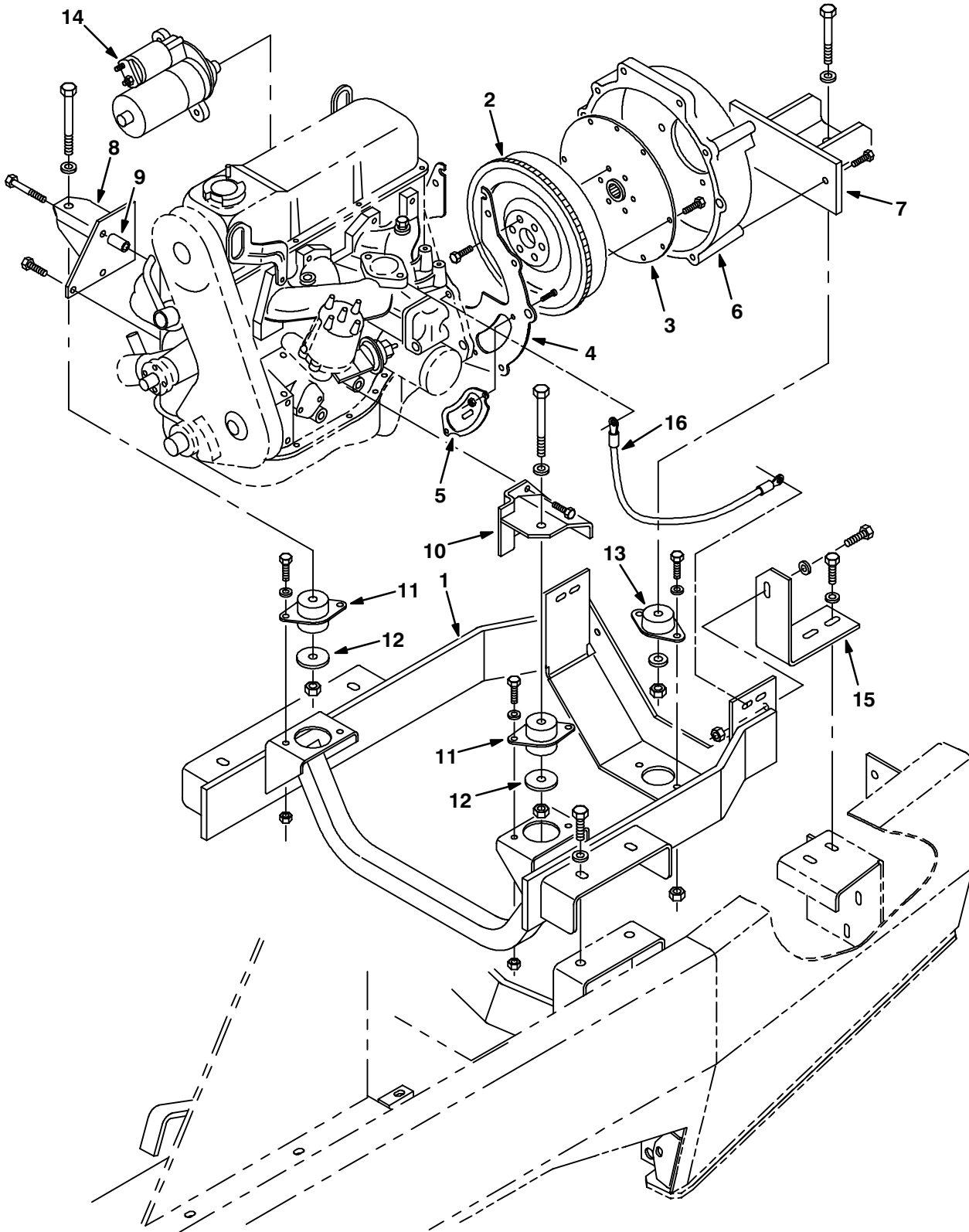

Fig. 31 – Engine Mount Group

Ref.	Tenant Part No.	Machine Serial Number	Description	Qty.
1	63154	(000000-001223)	Cradle Wldt, Engine, Gas	1
2	62424	(000000-001223)	Flywheel Assy, Rework	1
3	35980	(000000-001223)	Coupling Assy, Flywheel	1
4	36023	(000000-001223)	Plate, Engine Rear	1
5	36024	(000000-001223)	Cover, Access	1
6	65148	(000000-001223)	Housing, Flywheel, Machined	1
7	63535	(000000-001223)	Channel Wldt, Mtg, Engine,Rear	1
8	63055	(000000-001223)	Plate Wldt, Mtg, Motor, Rh	1
9	43609	(000000-001223)	Sleeve, .500B .69D1.281Cr.Cad	1
10	63068	(000000-001223)	Plate Wldt, Mtg, Motor, Lh	1
11	75768	(000000-001223)	Isolator	2
12	57048	(000000-001223)	Washer, .532B 2.13D .11Hr.Znc	2
13	63263	(000000-001223)	Isolator, Mtg	1
14	60938	(000000-001223)	Motor, Starting, Perm Mag, 12V (See Engine Breakdown)	1
15	63107	(000000-001223)	Angle	1
16	57773	(000000-001223)	Wire Assy. Ground	1

Fig. 32 – Engine Mount Group

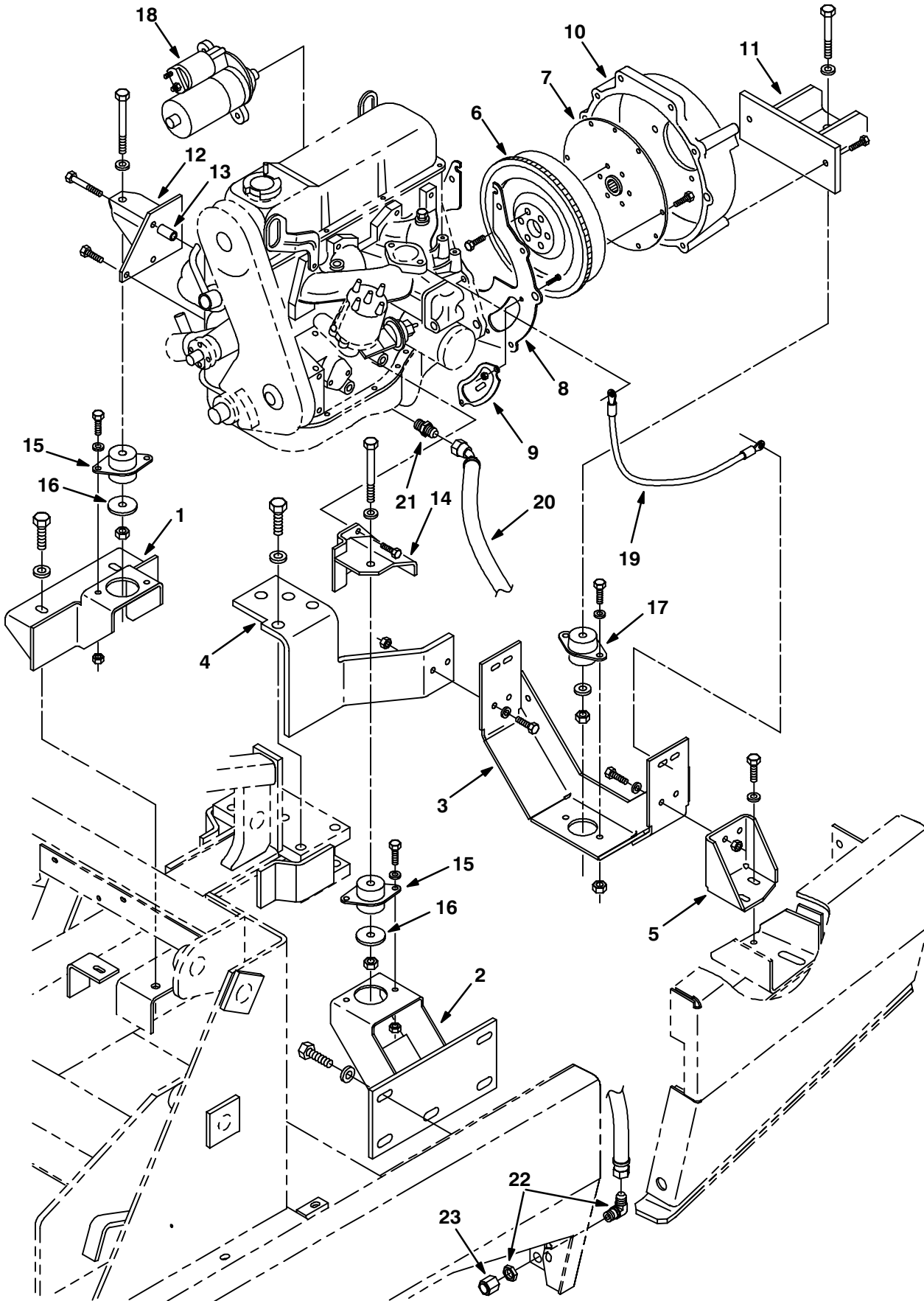

Fig. 32 – Engine Mount Group

Ref.	Tennant Part No.	Machine Serial Number	Description	Qty.
1	77425	(001224-001699)	Bracket Wldt, Mtg, Gas, Rh	1
2	77437	(001224-001699)	Bracket Wldt, Mtg, Gas, Lh	1
3	77430	(001224-001699)	Bracket Wldt, Mtg, Eng, Rear	1
4	77435	(001224-001699)	Bracket, Mtg, Engine, Rear	1
5	77434	(001224-001699)	Bracket, Mounting, Eng,Rear Lh	1
6	62424	(001224-001699)	Flywheel Assy, Rework	1
7	35980	(001224-001699)	Coupling Flywheel	1
8	36023	(001224-001699)	Plate, Engine Rear	1
9	36024	(001224-001699)	Cover Access	1
10	65148	(001224-001699)	Housing, Flywheel, Machined	1
11	63535	(001224-001699)	Channel Wldt, Mtg, Engine,Rear	1
12	63055	(001224-001699)	Plate Wldt, Mtg, Motor, Rh	1
13	43609	(001224-001699)	Sleeve, .500B .69D1.281Cr.Cad	1
14	63068	(001224-001699)	Plate Wldt, Mtg, Motor, Lh	1
15	75768	(001224-001699)	Isolator	2
16	57048	(001224-001699)	Washer, .532B 2.13D .11Hr.Znc	2
17	63263	(001224-001699)	Isolator, Mtg	1
18	60938	(001224-001699)	Motor, Starting, Perm Mag, 12V (See Engine Breakdown)	1
19	57773	(001224-001699)	Wire Ass'Y-Elect.,Ground	1
20	71558	(001224-001699)	Hose-Hyd	1
21	12976	(001224-001699)	Ftg-Hyd Str Mom14/Jm08	1
22	34365	(001224-001699)	Ftg-Hyd E90 Jm08/Jm08	1
23	60090	(001224-001699)	Ftg-Hyd Cap Jf08	1

Fig. 33 – Engine Mount Group

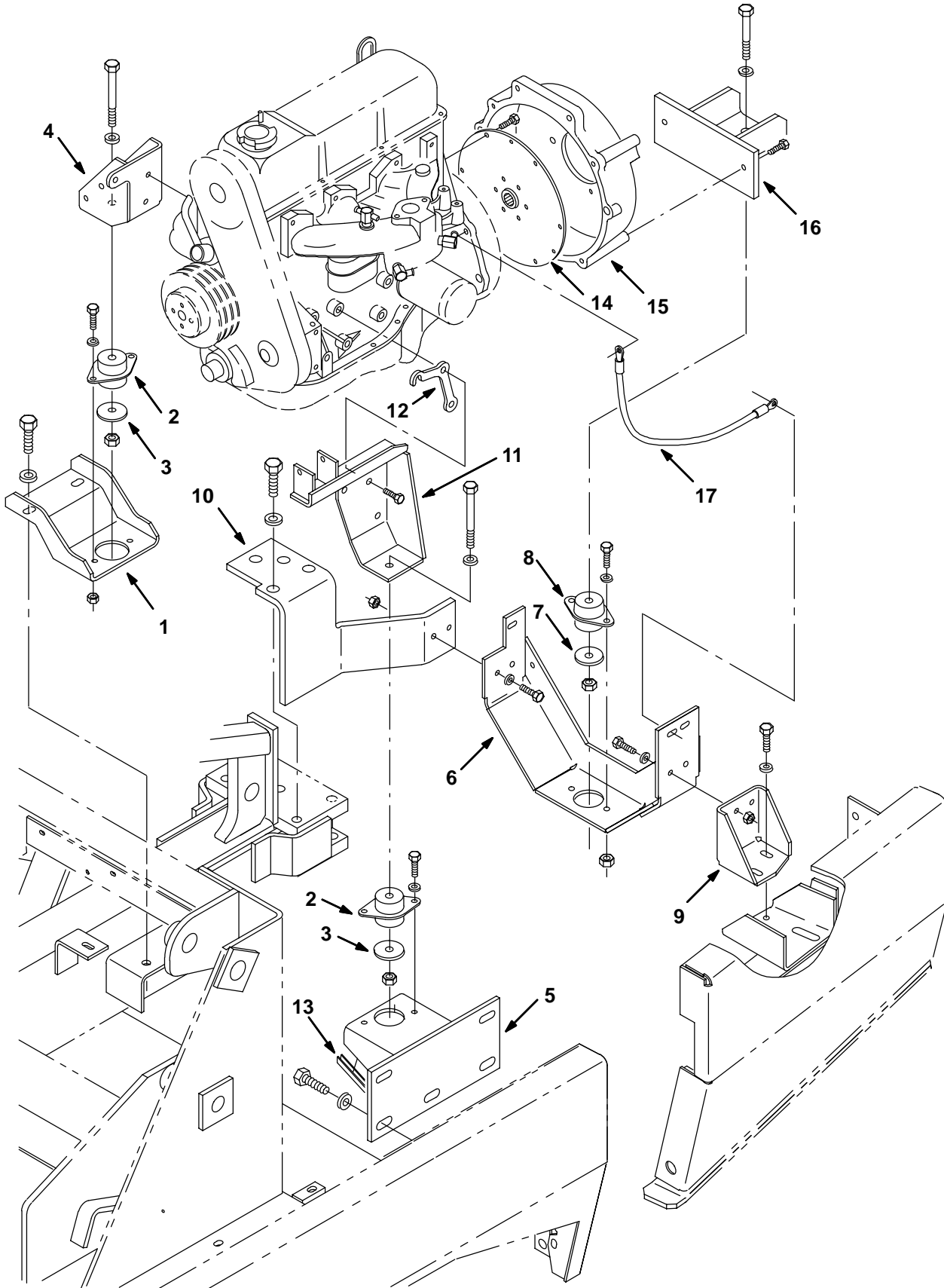

Fig. 33 – Engine Mount Group

Ref.	Tenant Part No.	Machine Serial Number	Description	Qty.
1	83674	(001700–) Bracket, Mtg, Eng, Rh	1
2	63695	(001700–) Isolator, Mounting	2
3	04414	(001700–) Washer, .531B 1.88D .12Hard Zn	2
4	83662	(001700–) Bracket, Eng Mtg Rh	1
5	83672	(001700–) Bracket Wldt, Mtg, Eng, Lh	1
6	77430	(001700–) Bracket, Mounting, Eng, Rear	1
7	57048	(001700–) Washer, .532B 2.13D .11Hr.Znc	1
8	63263	(001700–) Isolator, Mtg	1
9	77434	(001700–) Bracket, Mounting, Eng,Rear Lh	1
10	77435	(001700–) Bracket, Mtg, Eng, Rear	1
11	83670	(001700–) Bracket Wldt, Eng/Alt Mount	1
12	83673	(001700–) Plate, Spacer, Mtg, Eng 2.3Fd	1
13	13173	(001700–) Molding, Trim 3/16–5/16 5.0	2
14	35980	(001700–) Coupling Flywheel	1
15	83689	(001700–) Housing, Flywheel, Machined	1
16	63535	(001700–) Channel Wldt, Mtg, Engine,Rear	1
17	57773	(001700–) Wire Ass'Y–Elect.,Ground	1

Fig. 34 – Carburetor and Governor Group, Gasoline

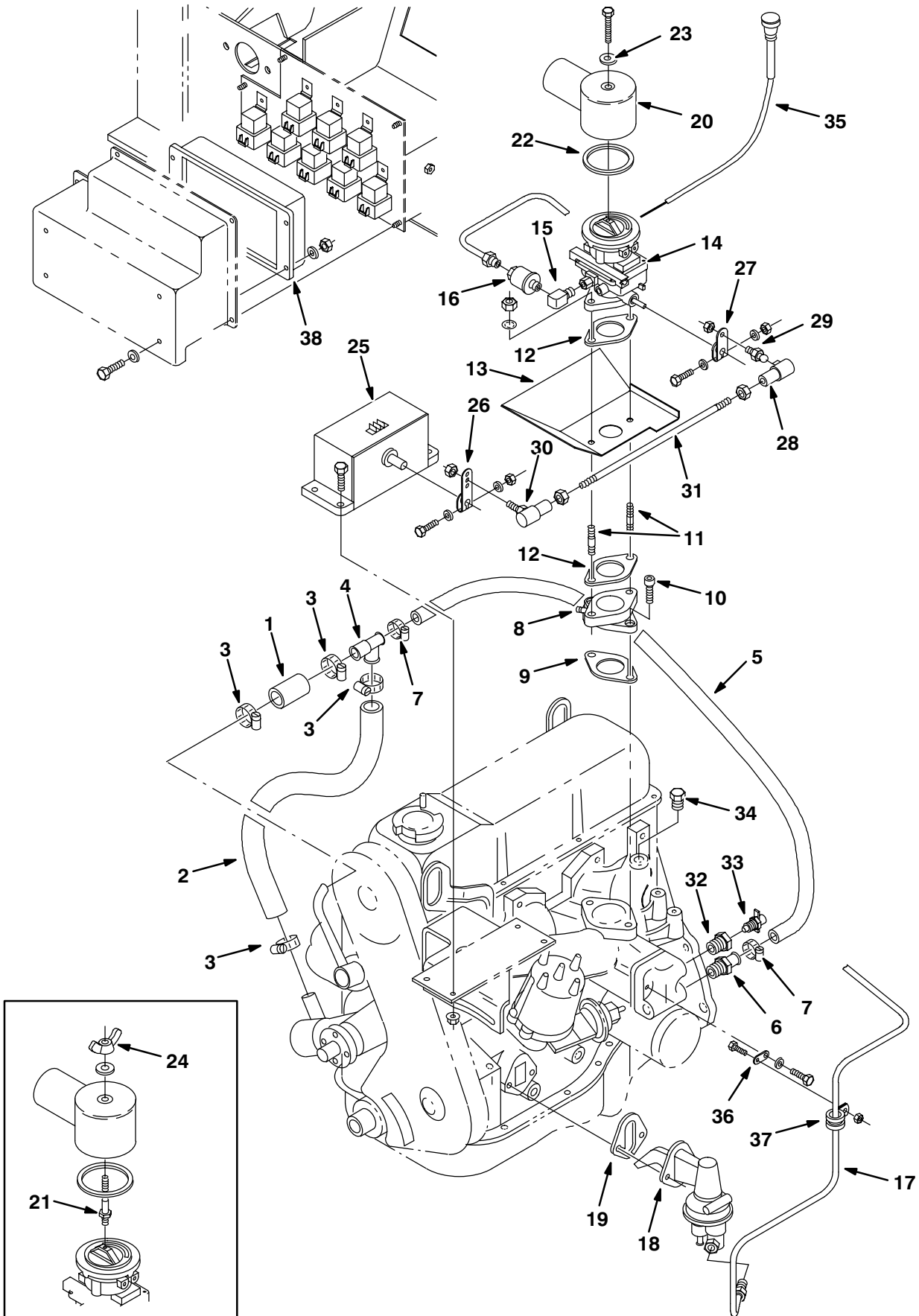

Fig. 34 – Carburetor and Governor Group, Gasoline

Ref.	Tennant Part No.	Machine Serial Number	Description	Qty.
1	60716	(000000-001699)	Hose, Rbr .62 Id X 2.0 Lg	1
2	60717	(000000-001699)	Hose, Rbr .62 Id X 11.5 Lg	1
3	63810	(000000-001699)	Clamp-Wormdrive, 0.56- 1.06D	4
4	36035	(000000-001699)	Ftg,Plstc,Tee,Barb.38-.62-.62	1
5	60718	(000000-001699)	Hose, Rbr .38ldx .620D 35.0Lg	1
6	36159	(000000-001699)	Ftg-Brs Str Bm06/Pm06	1
7	54333	(000000-001699)	Clamp-Wormdrive, 0.31- 0.88D	2
8	79448	(000000-001699)	Adaptor, Carb	1
9	36021	(000000-001699)	Gasket, Carburetor	1
10	39309	(000000-001699)	Scr Soc M10X1.5 25	2
11	36026	(000000-001699)	Rod-Thrd 2End M08X1.3 X 7.87	2
12	74443	(000000-001699)	Gasket, Carburetor	2
13	78812	(000000-001699)	Plate, Drip Shield	1
∇ 14	36020	(000000-001699)	Carburetor For Lsg-423	1
	61945	(000000-001699)	Carb Repair Kit Ze	1
15	11984	(000000-001699)	Ftg-EI90 Npt/Npt 02Pf-02Pm	1
16	36050	(000000-001699)	Filter, Fuel	1
17	70641	(000000-001699)	Tube, Fueline, Gas	1
18	36041	(000000-001699)	Pump, Fuel	1
19	61303	(000000-001699)	Gasket, Fuel Pump 2.3L Ford	1
20	34997	(000000-001699)	Elbow,Carb,Gas	1
21	34996	(000000-001425)	Stud,Air Cleaner Gas .25-20	1
22	16738	(000000-001699)	Gasket, Carburetor Air Horn	1
23	24924	(000000-001699)	Washer, .281B .62D .06Nylon	1
24	07252	(000000-001425)	Nut, Wing, Air Horn	1
25	07539	(000000-001699)	Actuator, Ele, Governor	1
26	30481	(000000-001699)	Lever, Governor Actuator	1
27	30480	(000000-001699)	Lever, Carburetor	1
28	50332-1	(000000-001699)	Balljoint .250-28 Body/Clip	1
29	50332-2	(000000-001699)	Balljoint .250-28 Ball Stud	1
30	14601	(000000-001699)	Balljoint .250-28	1
31	70723	(000000-001699)	Rod, Actuator, Control	1
32	15791-1	(000000-001699)	Ftg-Hyd Str Pm06/Pf04	1
33	54911-32	(000000-001699)	Draincock,End.Block	1
34	02247	(000000-001699)	Ftg-Plug Npt 04Pm Hx Soc	1
35	47313A	(000000-001699)	Cable Assy,Choke 67.00Lg	1
36	77587	(001182-001699)	Strap, Mtg, Fueline	1
37	26395-2	(001182-001699)	Clamp, Cable, 0.38D 0.38W Stl	1
38	31989	(000000-001699)	Control Box, Gov., 3-speed	1

Fig. 35 – Carburetor and Governor Group, Gasoline

I

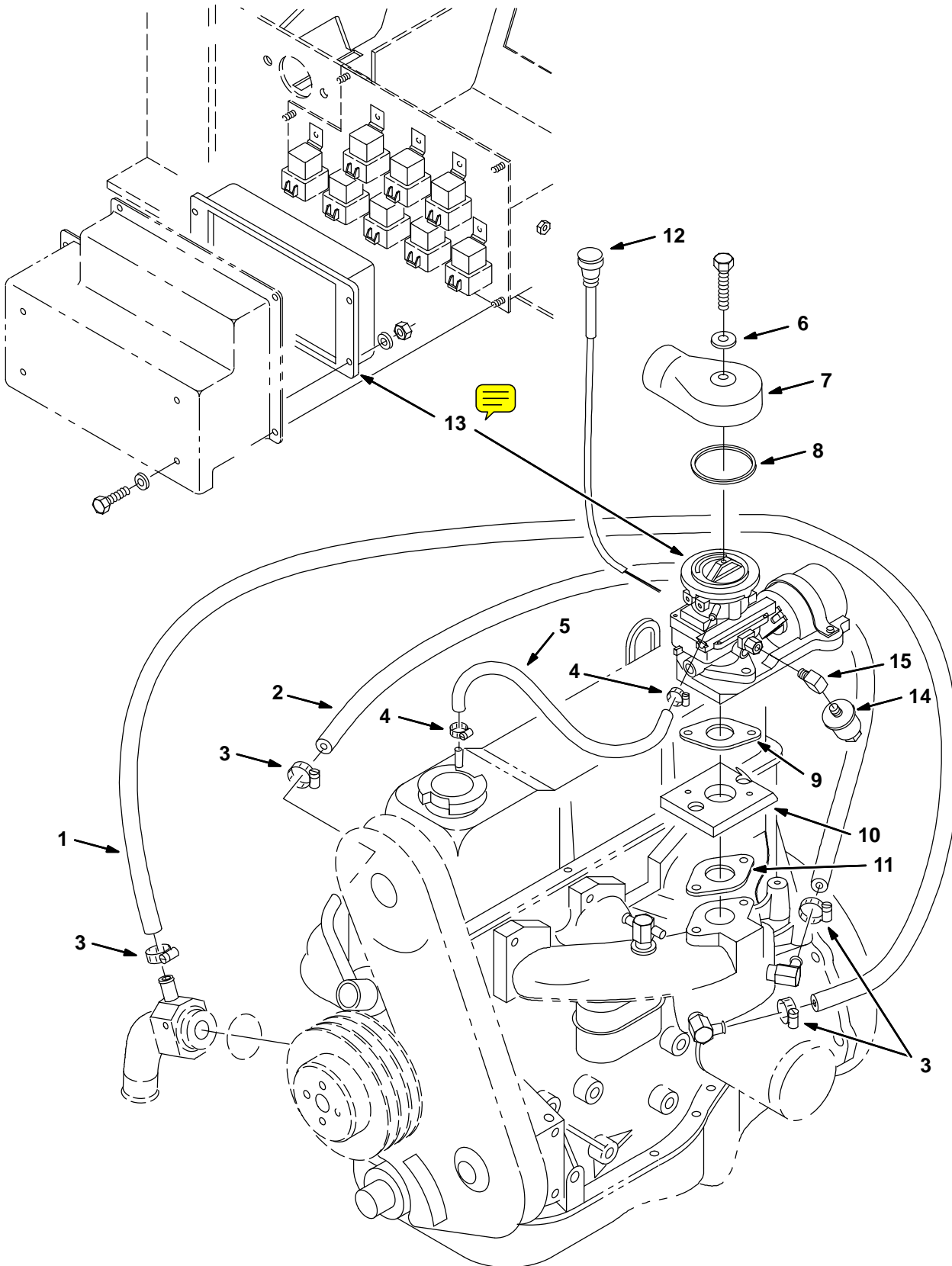

Fig. 35 – Carburetor and Governor Group, Gasoline

Ref.	Tennant Part No.	Machine Serial Number	Description	Qty.
1	30389	(001700–) Hose, Heater .62ldx53.0Lg	1
2	13048	(001700–) Hose, .62 Id X 38. Lng Heater	1
3	63810	(001700–) Clamp–Wormdrive, 0.56– 1.06D	4
4	43844	(001700–) Clamp–Wormdrive, 0.25– 0.62D	2
5	70876	(001700–) Hose, Rubber.38ldx.62Od 21.0Lg	1
6	24924	(001700–) Washer, .281B .62D .06Nylon	1
7	57934	(001700–) Adaptor, Elbow, Carb, Gas	1
8	16738	(001700–) Gasket, Carburetor Air Horn	1
9	74443	(001700–) Gasket, Carb To Engine	1
10	83686	(001700–) Adapter, Carburetor, Ford 2.3	1
11	36021	(001700–) Gasket, Carburetor	1
12	47313A	(001700–) Cable Assy, Choke 67.00Lg	1
∇ 13	83678	(001700–) Governor Assy, Gas	1
14	36050	(001700–) Filter, Fuel	1
15	11984	(001700–) Ftg, EI90 Npt/02Pf–02Pm	1

Fig. 36 – Carburetor and Governor Group, LPG

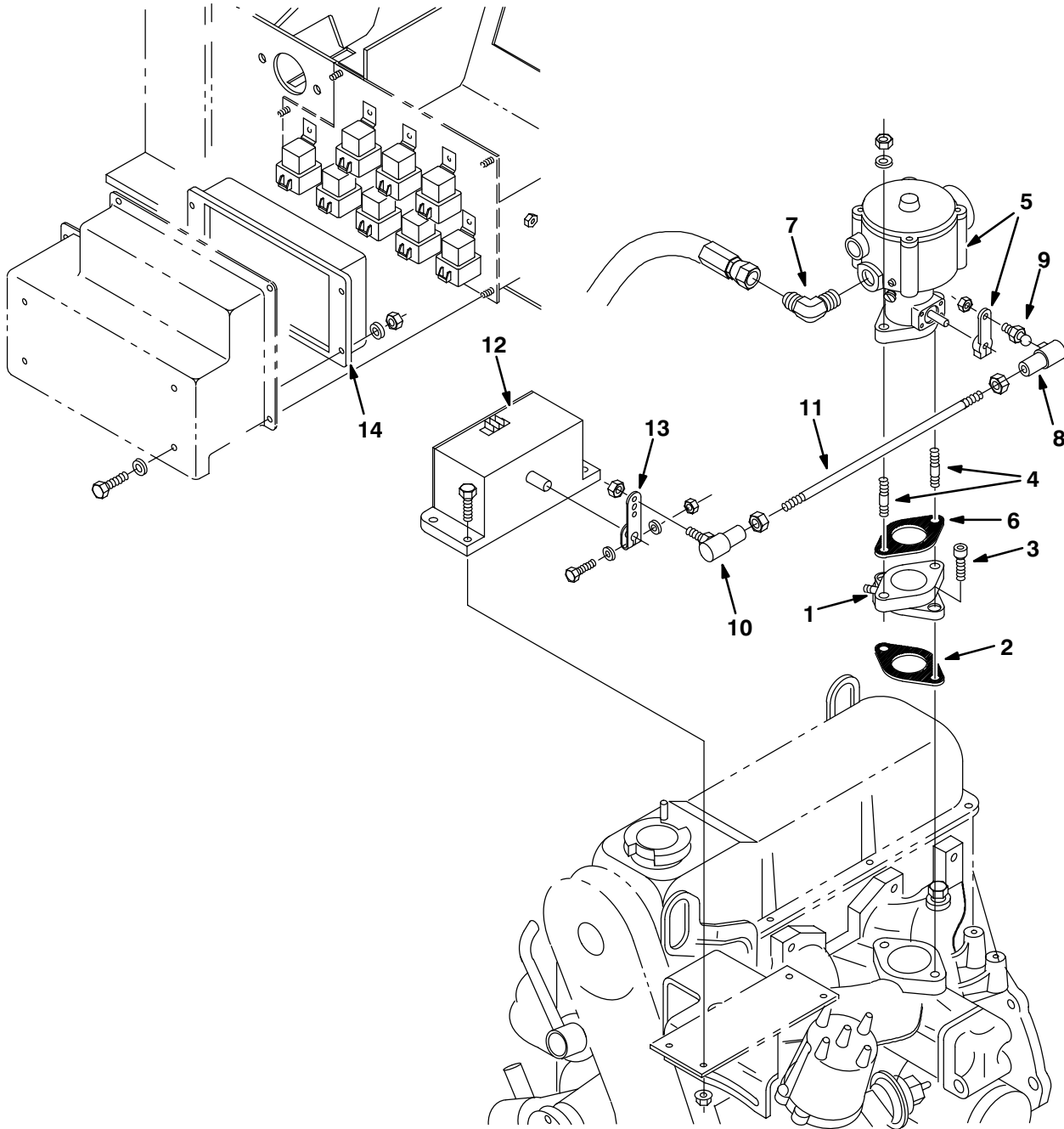

Fig. 36 – Carburetor and Governor Group, LPG

Ref.	Tenant Part No.	Machine Serial Number	Description	Qty.
1	79448	(000000-001699)	Adaptor, Carb	1
2	36021	(000000-001699)	Gasket, Carburetor	1
3	39309	(000000-001699)	Scr Soc M10X1.5 25	2
4	36026	(000000-001699)	Rod-Thrd 2End M08X1.3 X 7.87	2
∇ 5	82679	(000000-001699)	Carburetor, Lpg W/Gasket	1
	02742	(000000-001699)	Carburetor Kit, Lpg	1
6	54912-8	(000000-001699)	Gasket – Carburetor	1
7	46611	(000000-001699)	Ftg-Hyd E90 Pm08/Jm10	1
8	50332-1	(000000-001699)	Balljoint .250-28 Body/Clip	1
9	50332-2	(000000-001699)	Balljoint .250-28 Ball Stud	1
10	14601	(000000-001699)	Balljoint .250-28	1
11	70723	(000000-001699)	Rod, Actuator, Control	1
12	07539	(000000-001699)	Actuator, Ele, Governor	1
13	30481	(000000-001699)	Lever, Governor Actuator	1
14	31989	(000000-001699)	Control Box, Gov, 3 speed	1

Fig. 37 – Carburetor and Governor Group, LPG

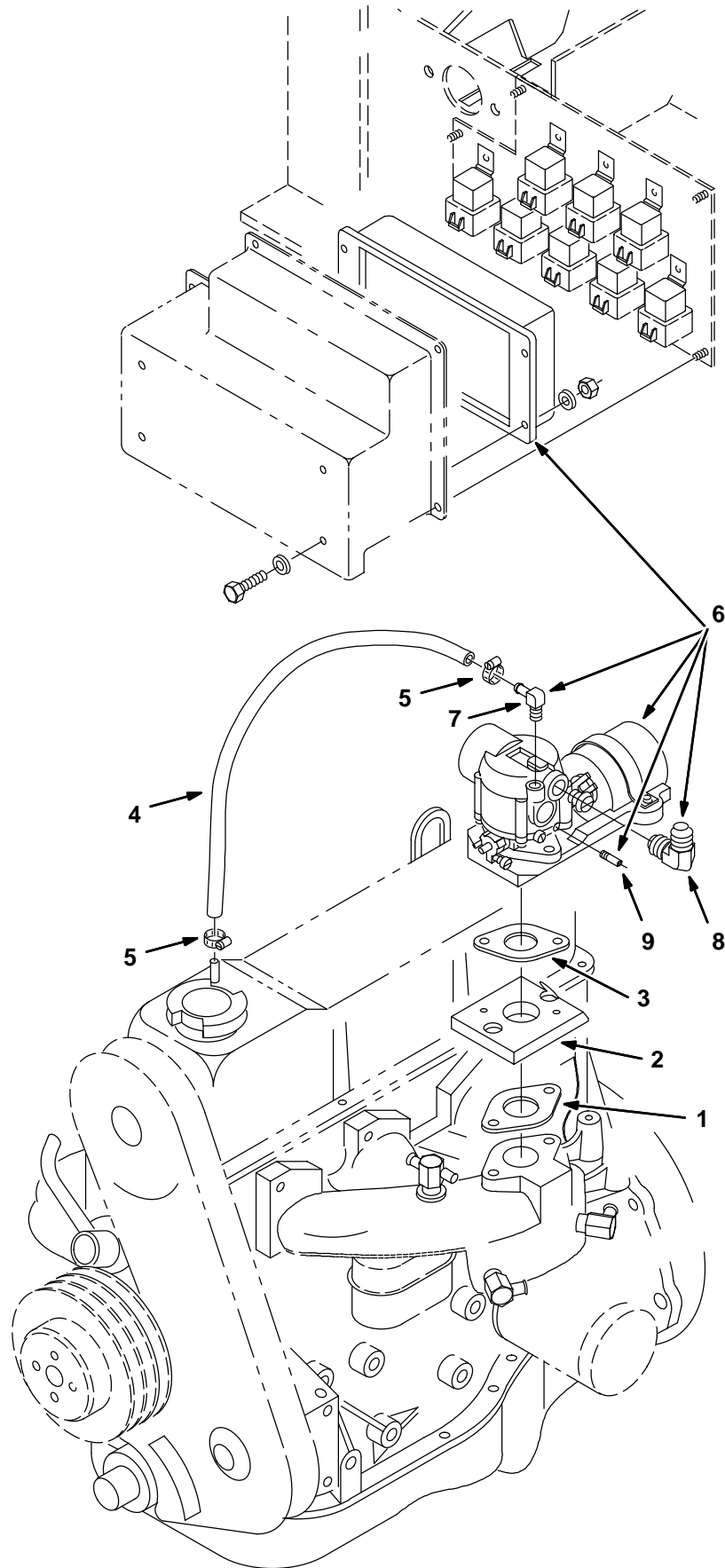

Fig. 37 – Carburetor and Governor Group, LPG

Ref.	Tenant Part No.	Machine Serial Number	Description	Qty.
1	36021	(001700–) Gasket, Carburetor	1
2	83686	(001700–) Adapter, Carburetor, Ford 2.3	1
3	74443	(001700–) Gasket, Carb To Engine	1
4	70876	(001700–) Hose, Rubber.38Idx.62Od 21.0Lg	1
5	43844	(001700–) Clamp–Wormdrive, 0.25– 0.62D	2
∇ 6	83679	(001700–) Governor Assy, Lpg 2.3	1
7	53029	(001700–) Ftg–Brs E90 Bm05/Pm02	1
8	69097	(001700–) Ftg–Hyd E90 Pm06/Jm10	1
9	74402	(001700–) Fitting, Special, Carb	1

Fig. 38 – Vaporizer Group, LPG

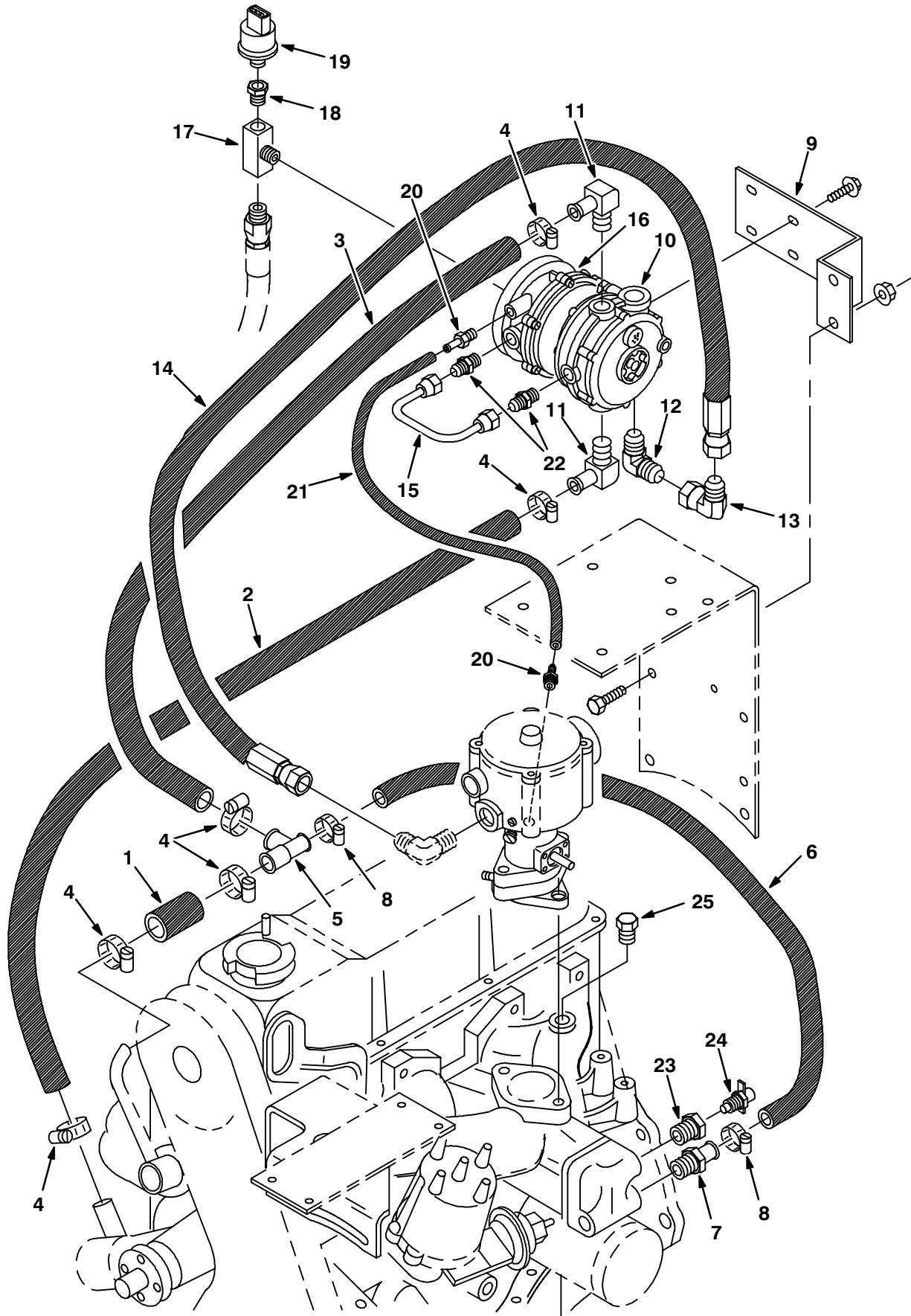

Fig. 38 – Vaporizer Group, LPG

Ref.	Tenant Part No.	Machine Serial Number	Description	Qty.
1	60716	(000000–001699)	Hose, Rbr .62 Id X 2.0 Lg	1
2	61870	(000000–001699)	Hose, .62Id X 31.0 Lng Heater	1
3	61869	(000000–001699)	Hose, .62Id X 24.0 Lng Heater	1
4	63810	(000000–001699)	Clamp–Wormdrive, 0.56– 1.06D	6
5	36035	(000000–001699)	Ftg,Plstc,Tee,Barb.38–.62–.62	1
6	60718	(000000–001699)	Hose, Rbr .38ldx .620D 35.0Lg	1
7	36159	(000000–001699)	Ftg–Brs Str Bm06/Pm06	1
8	54333	(000000–001699)	Clamp–Wormdrive, 0.31– 0.88D	2
9	70849	(000000–001699)	Bracket, Mtg, Vaporizer	1
∇ 10	54930	(000000–001699)	Vaporizer, Lpg	1
	55998	(000000–001699)	Vaporizer Repair Kit	1
11	51839	(000000–001699)	Ftg–Brs E90 Em10/Pm06	2
12	46611	(000000–001699)	Ftg–Hyd E90 Pm08/Jm10	1
13	54194	(000000–001699)	Ftg–Hyd E90 Jm10/Jf10	1
14	60725	(000000–001699)	Hose Lpg, 10Lpg 28In.Lg	1
15	59808	(000000–001699)	Fuelline,.375 Od	1
∇ 16	59807	(000000–001699)	Filter, Fuelock	1
	65527	(000000–001699)	Repair Kit, Fuelock	1
17	53268	(000000–001699)	Ftg,Brass Tee 04Pf– 04Pm– 04Pf	1
18	17414	(000000–001699)	Ftg–Hyd Str Pm04/Pf02	1
19	23156	(000000–001699)	Switch, Pressure, Lpg	1
20	40607	(000000–001699)	Ftg–Brs Str Bm03/Pm02	2
21	34072	(000000–001699)	Hose Vac.,Rubber, .16ld,21.0L	1
22	15724	(000000–001699)	Ftg–Hyd Str Pm04/Jm06	2
23	15791–1	(000000–001699)	Ftg–Hyd Str Pm06/Pf04	1
24	54911–32	(000000–001699)	Draincock,End.Block	1
25	02247	(000000–001699)	Ftg–Plug NPT 04Pm Hx Soc	1

Fig. 39 – Vaporizer Group, LPG

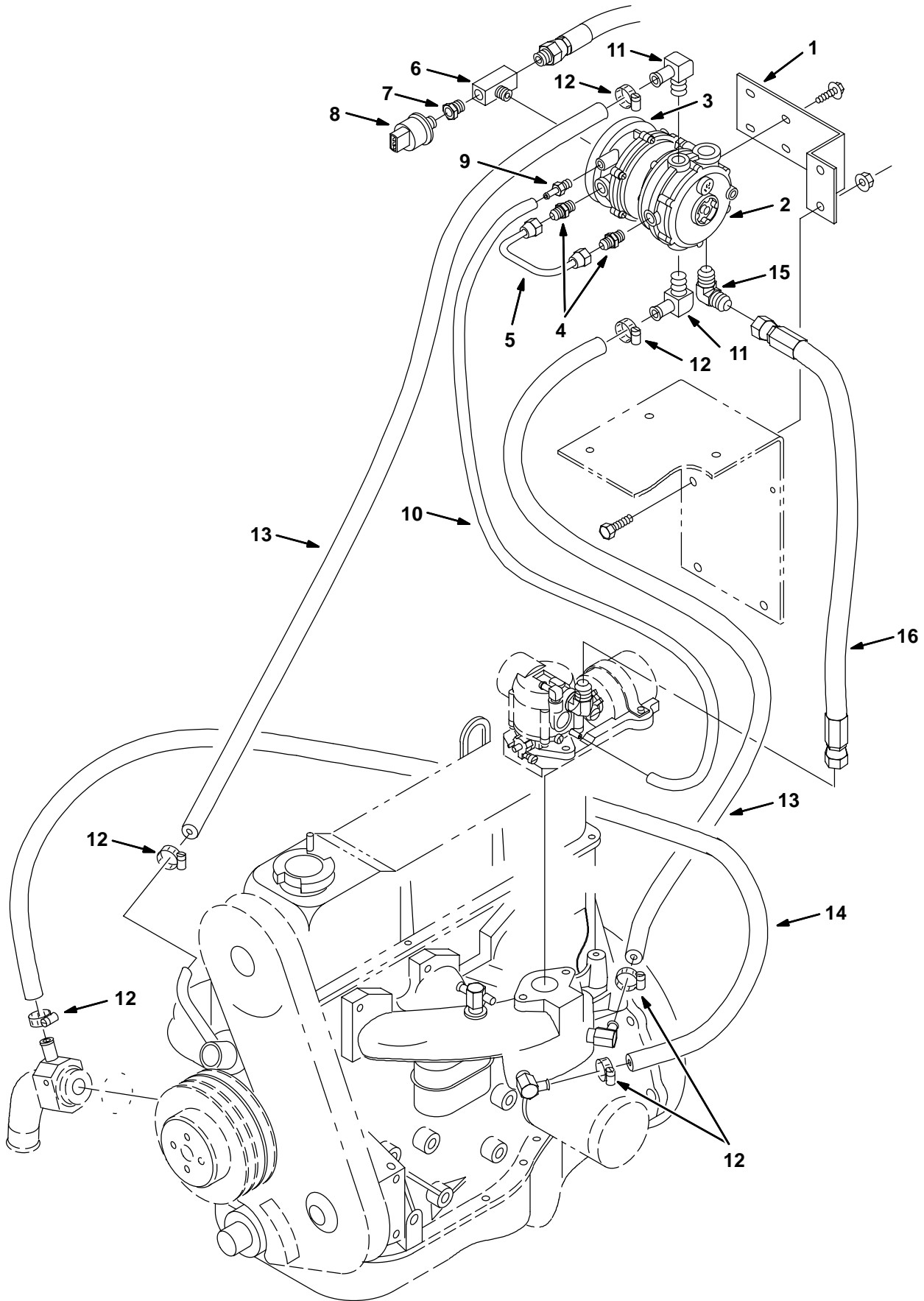

Fig. 39 – Vaporizer Group, LPG

Ref.	Tenant Part No.	Machine Serial Number	Description	Qty.
1	70849	(001700–)	Bracket, Mounting, Vaporizer	1
∇ 2	73018	(001700–)	Vaporizer, Lpg	1
	78880	(001700–)	Vaporizer Repair Kit	1
∇ 3	73020	(001700–)	Filter, Fuellockoff, Lpg	1
	65527	(001700–)	Fuellock Replacement Kit	1
4	15724	(001700–)	Ftg–Hyd Str Pm04/Jm06	2
5	59808	(001700–)	Fuelline, .375 Od	1
6	53268	(001700–)	Ftg,Brass Tee 04Pf– 04Pm– 04Pf	1
7	17414	(001700–)	Ftg–Hyd Str Pm04/Pf02	1
8	23156	(001700–)	Switch, Pressure, Lpg	1
9	40607	(001700–)	Ftg,Brass,St Bm03/Pm02	1
10	34072	(001700–)	Hose, Vacuum,.16ld X 21.0Lg	1
11	51839	(001700–)	Ftg–Brs E90 Bm10/Pm06	2
12	63810	(001700–)	Clamp–Wormdrive, 0.56– 1.06D	6
13	72979	(001700–)	Hose, .62ld X 20.0 Lng Heater	2
14	30389	(001700–)	Hose,Heater .62ldx53.0Lg	1
15	46611	(001700–)	Ftg–Hyd E90 Pm08/Jm10	1
16	60725	(001700–)	Hose Lpg, 10Lpg 28In.Lg	1

Fig. 40 – Air Cleaner Group, Gasoline

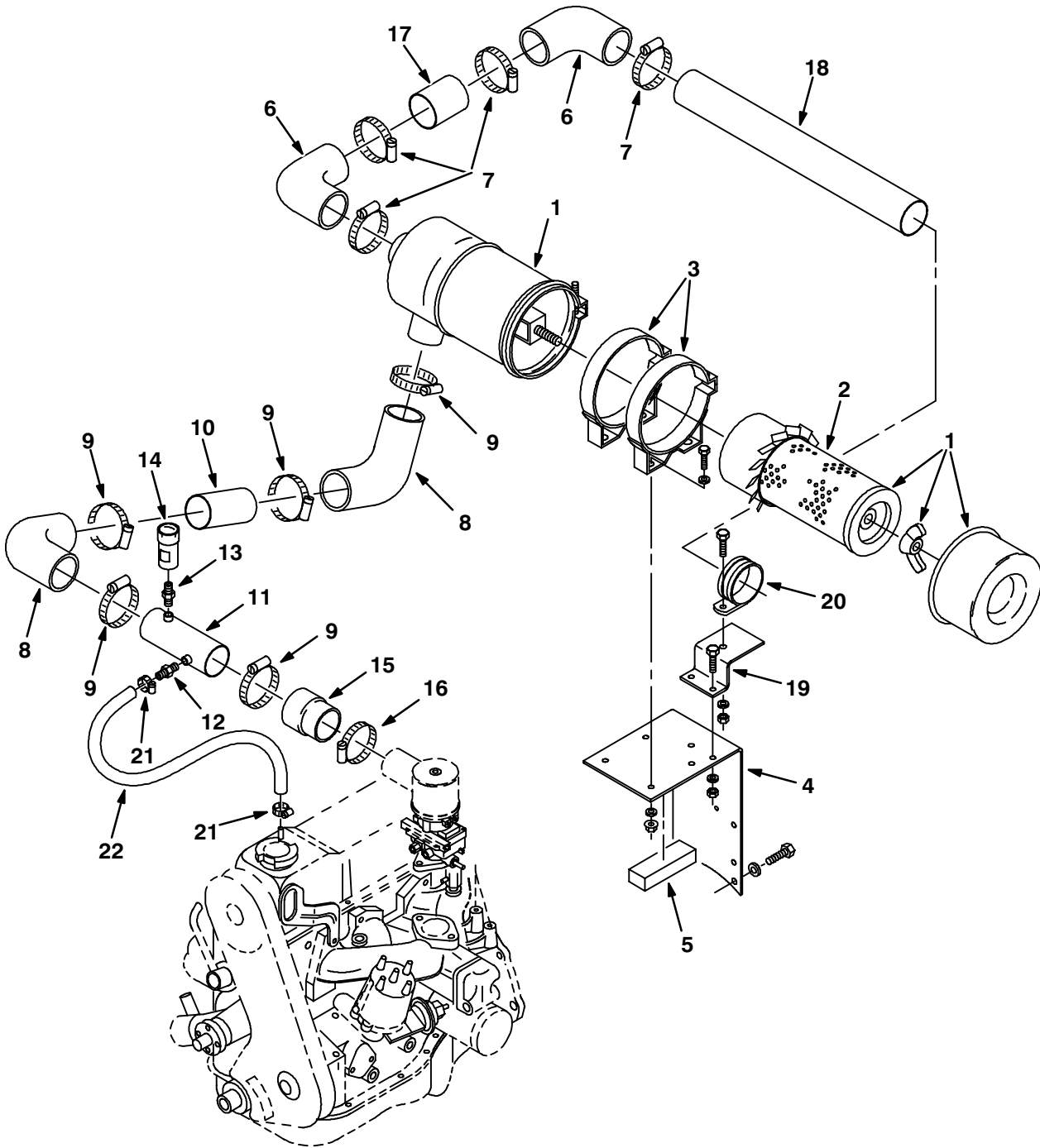

Fig. 40 – Air Cleaner Group, Gasoline

Ref.	Tennant Part No.	Machine Serial Number	Description	Qty.
∇ 1	76319	(000000–001140)	Air Cleaner	1
2	76335	(000000–001140)	Element Assy	1
3	76321	(000000–001140)	Band,Mtg.	2
4	70819	(000000–001140)	Bracket, Mtg, Air Cleaner	1
5	70869	(000000–001140)	Pad	1
6	16497	(000000–001140)	Elbow–Rubber,90Deg,2.5I.D.	2
7	43555	(000000–001140)	Clamp–Wormdrive, 1.62– 3.50D	4
8	52580–2	(000000–001229)	Elbow,90,Rubber 2.25Dia	2
9	14432	(000000–001229)	Clamp–Wormdrive, 1.81– 2.75D	5
10	73793	(000000–001229)	Tube, 2.25D 2.130 4.50,Stl	1
11	73795	(000000–001140)	Tube Wldt	1
12	27768	(000000–001140)	Ftg–Brs Str Em06/Pm02	1
13	51560–5	(000000–001140)	Filter,Service Indicator	1
14	03026	(000000–001140)	Indicator,Service,Air Filter	1
15	52992	(000000–001140)	Adaptor, Molded Donaldson2.25B	1
16	22297	(000000–001140)	Clamp–Wormdrive, 1.56– 2.50D	1
17	70838	(000000–001140)	Tube, Air Cleaner	1
18	73794	(000000–001140)	Tube, 2.50D 2.380 21.0,Stl	1
19	73796	(000000–001140)	Bracket	1
20	73735	(000000–001140)	Clamp, Cable	1
21	43844	(000000–001140)	Clamp–Wormdrive, 0.25– 0.62D	2
22	70876	(000000–001140)	Hose, Rbr .38I dx .62Od 21.0Lg	1

Fig. 41 – Air Cleaner Group, Gasoline

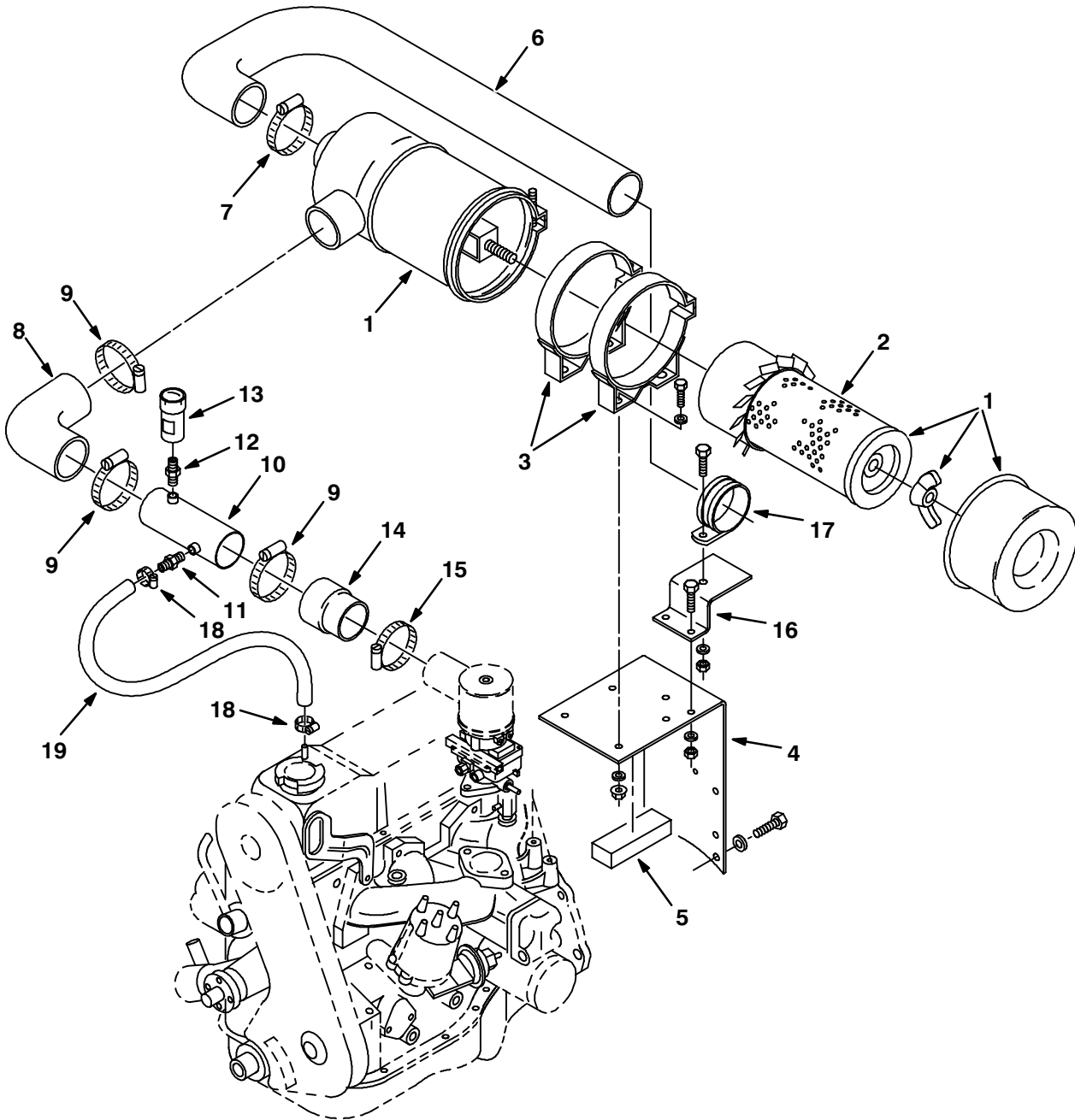

Fig. 41 – Air Cleaner Group, Gasoline

Ref.	Tenant Part No.	Machine Serial Number	Description	Qty.
∇ 1	76319	(001141-001699)	Air Cleaner	1
2	76335	(001141-001699)	Element Assy	1
3	76321	(001141-001699)	Band,Mtg.	2
4	70819	(001141-001699)	Bracket, Mtg, Air Cleaner	1
5	70869	(001141-001699)	Pad	1
6	76620	(001141-001699)	Hose, Molded, Air Intake	1
7	43555	(001141-001699)	Clamp-Wormdrive, 1.62- 3.50D	1
8	52580-2	(001230-001699)	Elbow,90,Rubber 2.25Dia	1
9	14432	(001230-001699)	Clamp-Wormdrive, 1.81- 2.75D	3
10	73795	(001230-001699)	Tube Wldt	1
11	27768	(001141-001699)	Fitting, Brass Em06/Pm02	1
12	51560-5	(001141-001699)	Adaptor, Filter, 1/8 Npt	1
13	03026	(001141-001699)	Indicator Service Air Filter	1
14	52992	(001141-001699)	Adaptor, Molded 2.25B	1
15	22297	(001141-001699)	Clamp-Wormdrive, 1.56- 2.50D L	1
16	73796	(001141-001699)	Bracket	1
17	78997	(001141-001699)	Clamp, Cable	1
18	43844	(001141-001699)	Clamp-Wormdrive, 0.25- 0.62D	2
19	70876	(001141-001699)	Hose, Rubber.38Idx.62Od 21.0Lg	1

Fig. 42 – Air Cleaner Group, Gasoline

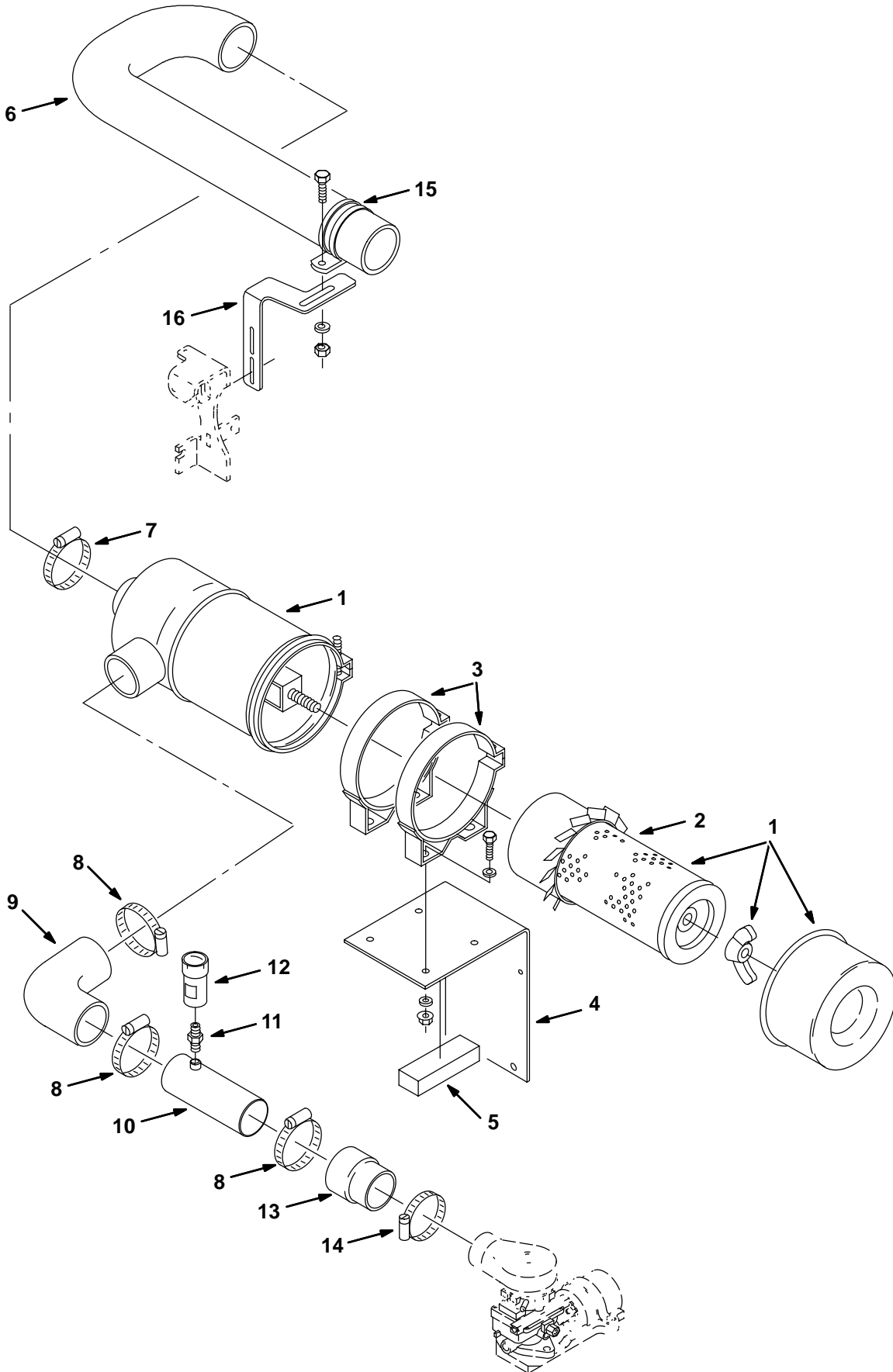

Fig. 42 – Air Cleaner Group, Gasoline

Ref.	Tennant Part No.	Machine Serial Number	Description	Qty.
∇ 1	76319	(001700–) Air Cleaner	1
2	76335	(001700–) Element Assy	1
3	76321	(001700–) Band,Mtg.	2
4	83741	(001700–) Bracket, Mtg, Air Cleaner	1
5	70869	(001700–) Pad	1
6	76620	(001700–) Hose, Molded, Air Intake	1
7	43555	(001700–) Clamp–Wormdrive, 1.62– 3.50D	1
8	14432	(001700–) Clamp–Wormdrive, 1.81– 2.75D	3
9	52580–2	(001700–) Elbow, Rubber 90 2.2ld	1
10	70639	(001700–) Tube Wldt, Air Cleaner	1
11	51560–5	(001700–) Adaptor, Filter, 1/8 Npt	1
12	03026	(001700–) Indicator Service Air Filter	1
13	52992	(001700–) Adaptor, Molded 2.25B	1
14	22297	(001700–) Clamp–Wormdrive, 1.56– 2.50D L	1
15	78997	(001700–) Clamp, Cable	1
16	83854	(001700–) Bracket, Mtg, Air Intake	1

Fig. 43 – Air Cleaner Group, LPG

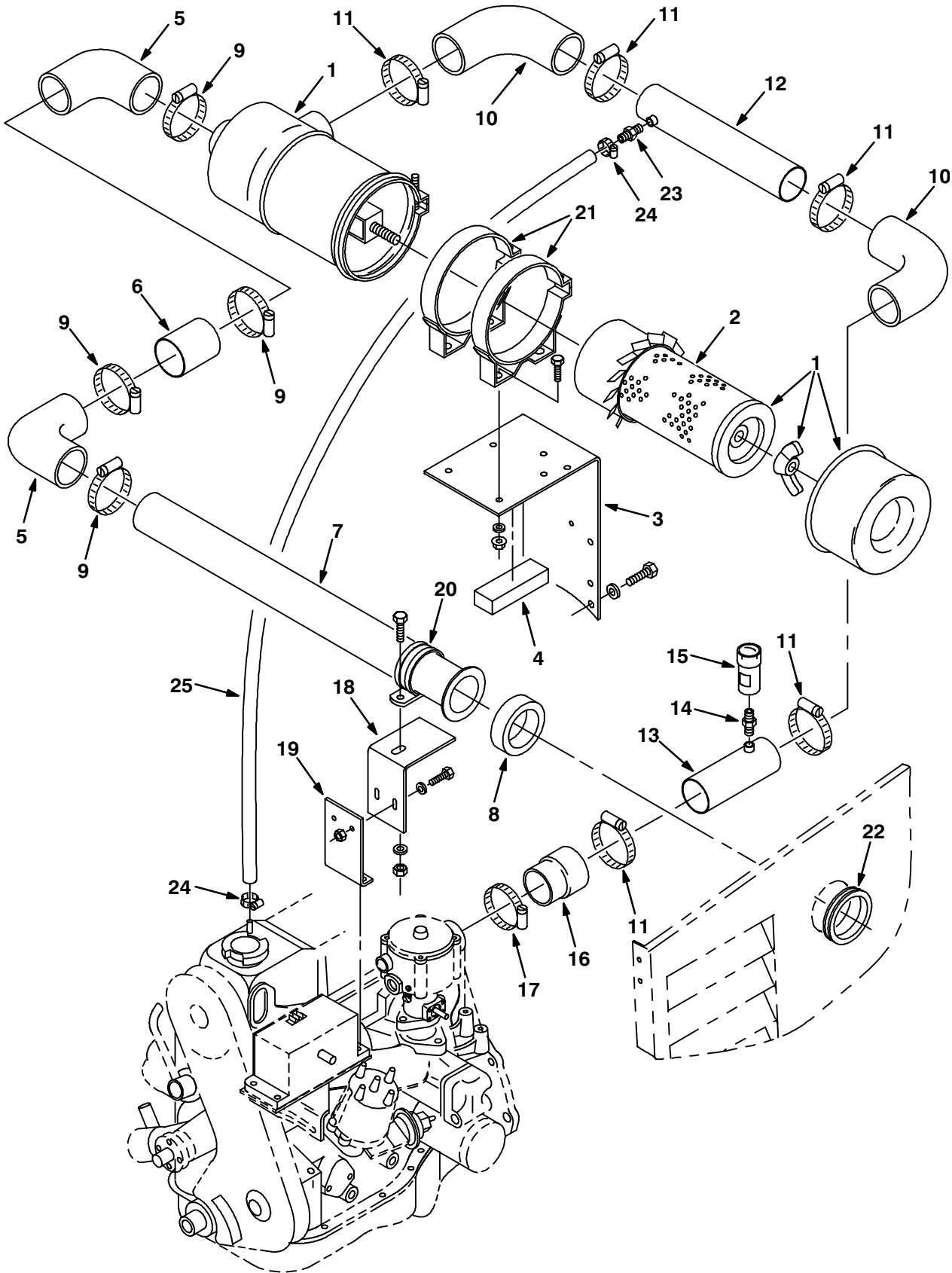

Fig. 43 – Air Cleaner Group, LPG

Ref.	Tenant Part No.	Machine Serial Number	Description	Qty.
∇ 1	76319	(000000–001140)	Air Cleaner	1
2	76335	(000000–001140)	Element	1
3	70819	(000000–001140)	Bracket, Mtg, Air Cleaner	1
4	70869	(000000–001140)	Pad	1
5	16497	(000000–001140)	Elbow–Rubber,90Deg,2.5I.D.	2
6	70838	(000000–001140)	Tube, Air Cleaner	1
7	73792	(000000–001140)	Tube Wldt, Air Cleaner	1
8	73789	(000000–001140)	Insulation, Acoustic, A Clnr	1
9	43555	(000000–001140)	Clamp–Wormdrive, 1.62– 3.50D	4
10	52580–2	(000000–001140)	Elbow,90,Rubber 2.25Dia	2
11	14432	(000000–001140)	Clamp–Wormdrive, 1.81– 2.75D	5
12	70643	(000000–001140)	Tube Wldt	1
13	70639	(000000–001140)	Tube Wldt, Air Cleaner	1
14	51560–5	(000000–001140)	Filter,Service Indicator	1
15	03026	(000000–001140)	Indicator,Service,Air Filter	1
16	52992	(000000–001140)	Adaptor, Molded Donaldson2.25B	1
17	22297	(000000–001140)	Clamp–Wormdrive, 1.56– 2.50D	1
18	73725	(000000–001140)	Bracket, Mtg	1
19	73788	(000000–001140)	Bracket, Mtg	1
20	73735	(000000–001140)	Clamp, Cable	1
21	76321	(000000–001140)	Band, Mtg	2
22	73742	(000000–001140)	Grommet, 3.00 Id	1
23	27768	(000000–001140)	Ftg–Brs Str Em06/Pm02	1
24	43844	(000000–001140)	Clamp–Wormdrive, 0.25– 0.62D	2
25	70876	(000000–001140)	Hose, Rbr .38Idx .62Od 21.0Lg	1

Fig. 44 – Air Cleaner Group, LPG

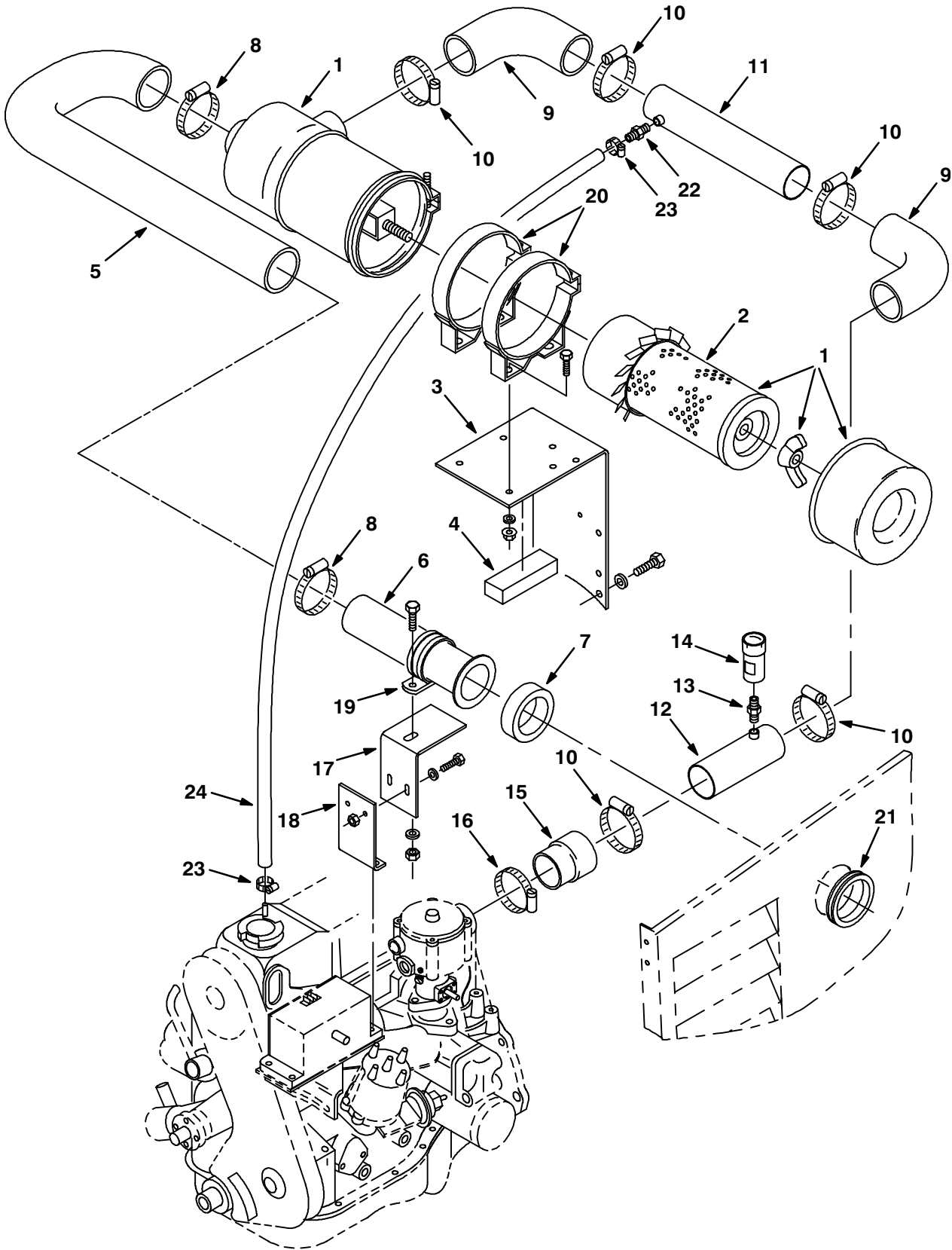

Fig. 44 – Air Cleaner Group, LPG

Ref.	Tennant Part No.	Machine Serial Number	Description	Qty.
∇ 1	76319	(001141-001699)	Air Cleaner	1
2	76335	(001141-001699)	Element Assy	1
3	70819	(001141-001699)	Bracket, Mtg, Air Cleaner	1
4	70869	(001141-001699)	Pad	1
5	76620	(001141-001699)	Hose, Molded, Air Intake	1
6	76633	(001141-001699)	Tube Wldt, Air Cleaner	1
7	73789	(001141-001699)	Insulation, Acoustic, Air Clnr	1
8	43555	(001141-001699)	Clamp-Wormdrive, 1.62- 3.50D	2
9	52580-2	(001141-001699)	Elbow,90,Rubber 2.25Dia	2
10	14432	(001141-001699)	Clamp-Wormdrive, 1.81- 2.75D	5
11	70643	(001141-001699)	Tube Wldt	1
12	70639	(001141-001699)	Tube Wldt, Air Cleaner	1
13	51560-5	(001141-001699)	Adaptor, Filter, 1/8 Npt	1
14	03026	(001141-001699)	Indicator Service Air Filter	1
15	52992	(001141-001699)	Adaptor, Molded 2.25B	1
16	22297	(001141-001699)	Clamp-Wormdrive, 1.56- 2.50D L	1
17	73725	(001141-001699)	Bracket, Mounting	1
18	73788	(001141-001699)	Bracket, Mounting	1
19	78997	(001141-001699)	Clamp, Cable	1
20	76321	(001141-001699)	Band,Mtg.	2
21	73742	(001141-001699)	Grommet, 3.00ld	1
22	27768	(001141-001699)	Fitting, Brass Em06/Pm02	1
23	43844	(001141-001699)	Clamp-Wormdrive, 0.25- 0.62D	2
24	70876	(001141-001699)	Hose, Rubber.38ldx.62Od 21.0Lg	1

Fig. 45 – Air Cleaner Group, LPG

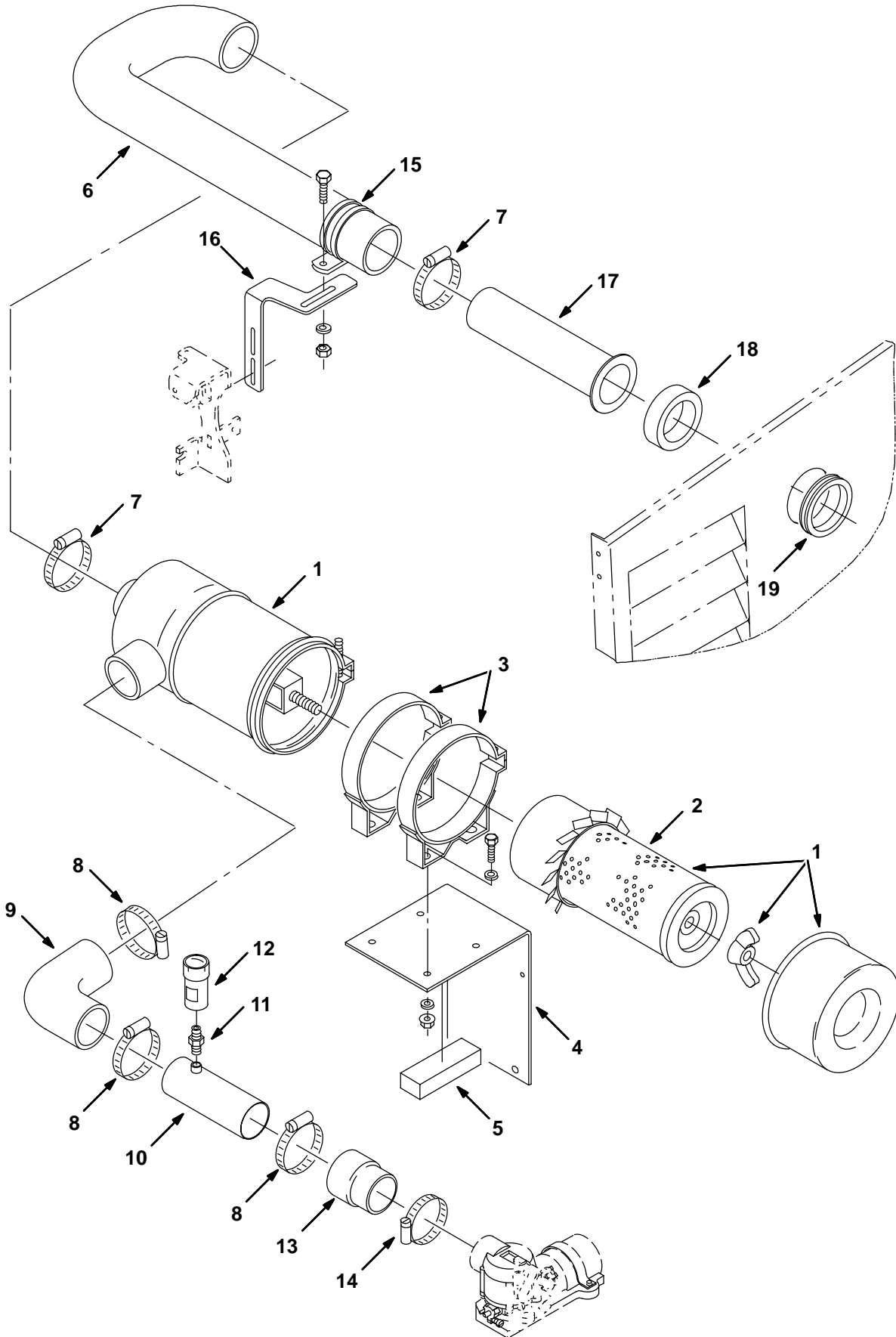

Fig. 45 – Air Cleaner Group, LPG

Ref.	Tenant Part No.	Machine Serial Number	Description	Qty.
∇ 1	76319	(001700–) Air Cleaner	1
2	76335	(001700–) Element Assy	1
3	76321	(001700–) Band,Mtg.	2
4	83741	(001700–) Bracket, Mtg, Air Cleaner	1
5	70869	(001700–) Pad	1
6	76620	(001700–) Hose, Molded, Air Intake	1
7	43555	(001700–) Clamp–Wormdrive, 1.62– 3.50D	2
8	14432	(001700–) Clamp–Wormdrive, 1.81– 2.75D	3
9	52580–2	(001700–) Elbow, Rubber 90 2.2ld	1
10	70639	(001700–) Tube Wldt, Air Cleaner	1
11	51560–5	(001700–) Adaptor, Filter, 1/8 Npt	1
12	03026	(001700–) Indicator Service Air Filter	1
13	52992	(001700–) Adaptor, Molded 2.25B	1
14	22297	(001700–) Clamp–Wormdrive, 1.56– 2.50D L	1
15	78997	(001700–) Clamp, Cable	1
16	83854	(001700–) Bracket, Mtg, Air Intake	1
17	76633	(001700–) Tube Wldt, Air Cleaner	1
18	73789	(001700–) Insulation, Acoustic, Air Clnr	1
19	73742	(001700–) Grommet, 3.00ld	1

Fig. 46 – Muffler Group

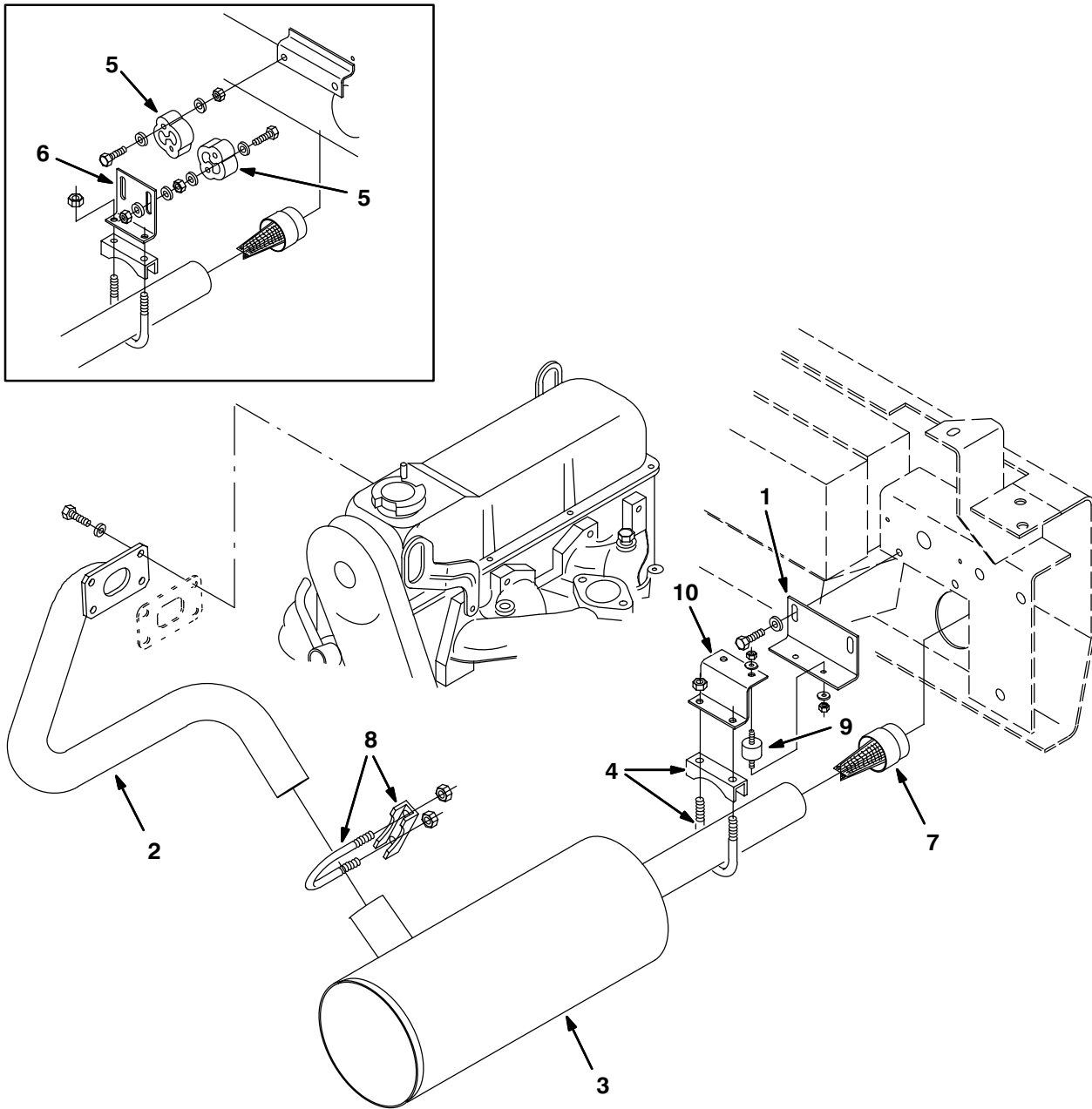

Fig. 46 – Muffler Group

Ref.	Tennant Part No.	Machine Serial Number	Description	Qty.
1	21138	(001309–) Bracket, Tail Pipe	1
2	70631	(000000–) Pipe Wldt, Exhaust, Gas/Lpg	1
3	76383	(000000–) Muffler, Exhaust	1
4	05881	(000000–) Clamp–Muffler,For 2.00 Od Tube	1
5	65158	(000000–001308) Isolator, Exhaust	2
6	76382	(000000–001308) Bracket, Tailpipe	1
7	70832	(000000–) Screen, Muffler	1
8	05880	(000000–) Clamp–Muffler,For 1.87 Od Tube	1
9	82661	(001309–) Isolator–Vibration .25–20	2
10	21136	(001309–) Bracket, Tail Pipe	1

Fig. 47 – Fuel Tank Group, Gas

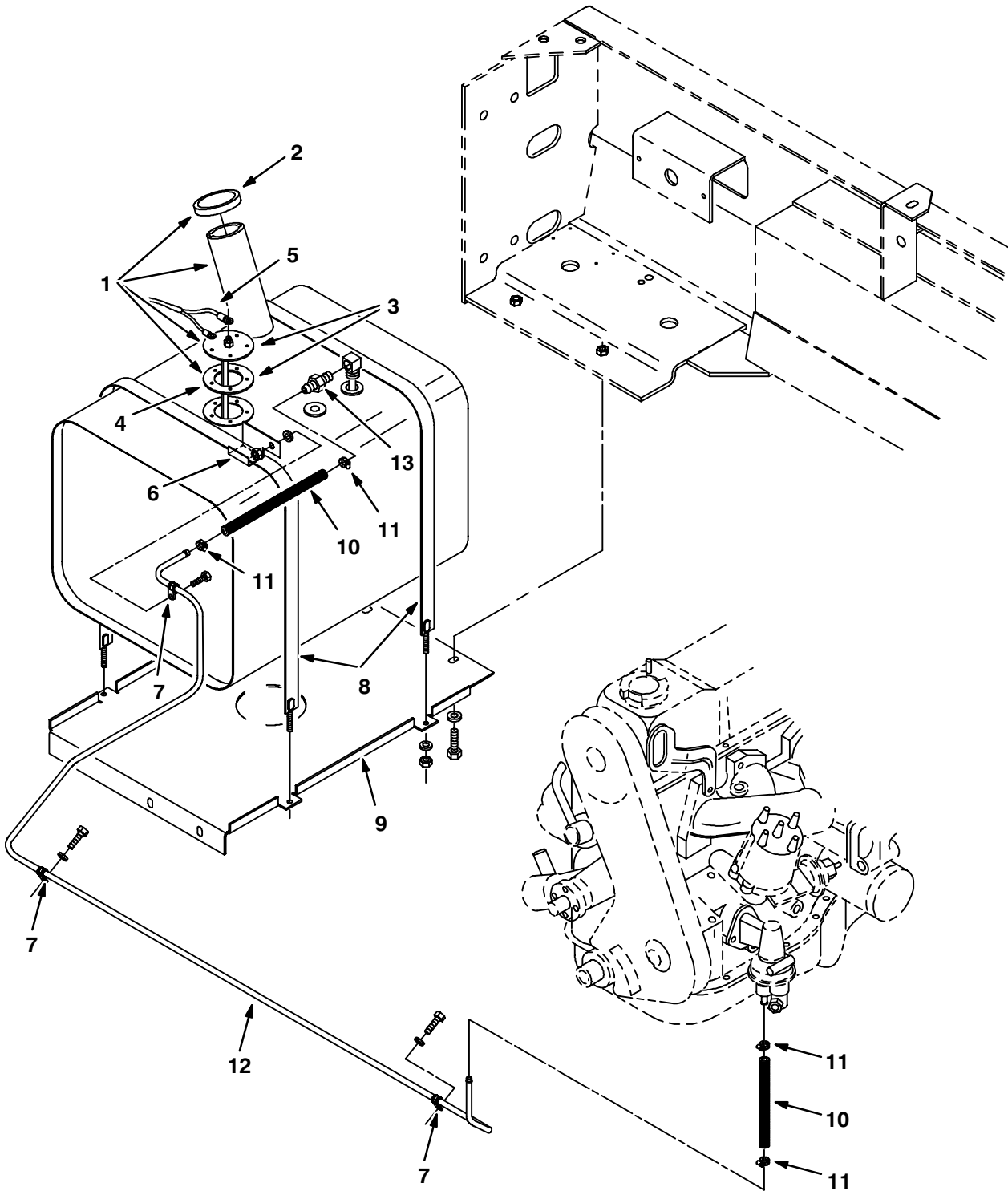

Fig. 47 – Fuel Tank Group, Gas

	Ref.	Tenant Part No.	Machine Serial Number	Description	Qty.
∇	1	63205	(000000–001102)	Tank, Fuel	1
∇	1	76907	(001103–001699)	Tank, Fuel	1
	2	48267	(000000–001699)	Cap, Gas	1
∇	3	07873	(000000–001699)	Send Unit	1
	4	14131	(000000–001699)	Gasket, 2.7D 1.5B.12T 5/ 2.1Bc	1
	5	70401	(000000–001699)	Harness, Tank, Fuel	1
	6	70767	(000000–001699)	Tab, Fuelline	1
	7	76736	(000000–001699)	Clamp–Cable, 0.38Dia 0.62Wth	3
	8	87396	(000000–001699)	Strap Weldmt, Gas Tank	2
	9	70477	(000000–001699)	Plate, Mtg, Tank, Gas	1
	10	70629	(000000–001699)	Hose, Rbr .312 Id X 6.0 Lg	2
	11	43844	(000000–001699)	Clamp–Wormdrive, 0.25– 0.62D	4
	12	70630	(000000–001699)	Tube, Fuelline, Gas/Die	1
	13	70645	(000000–001699)	Fitting, Barbed	1

Fig. 48 – Fuel Tank Group, Gas

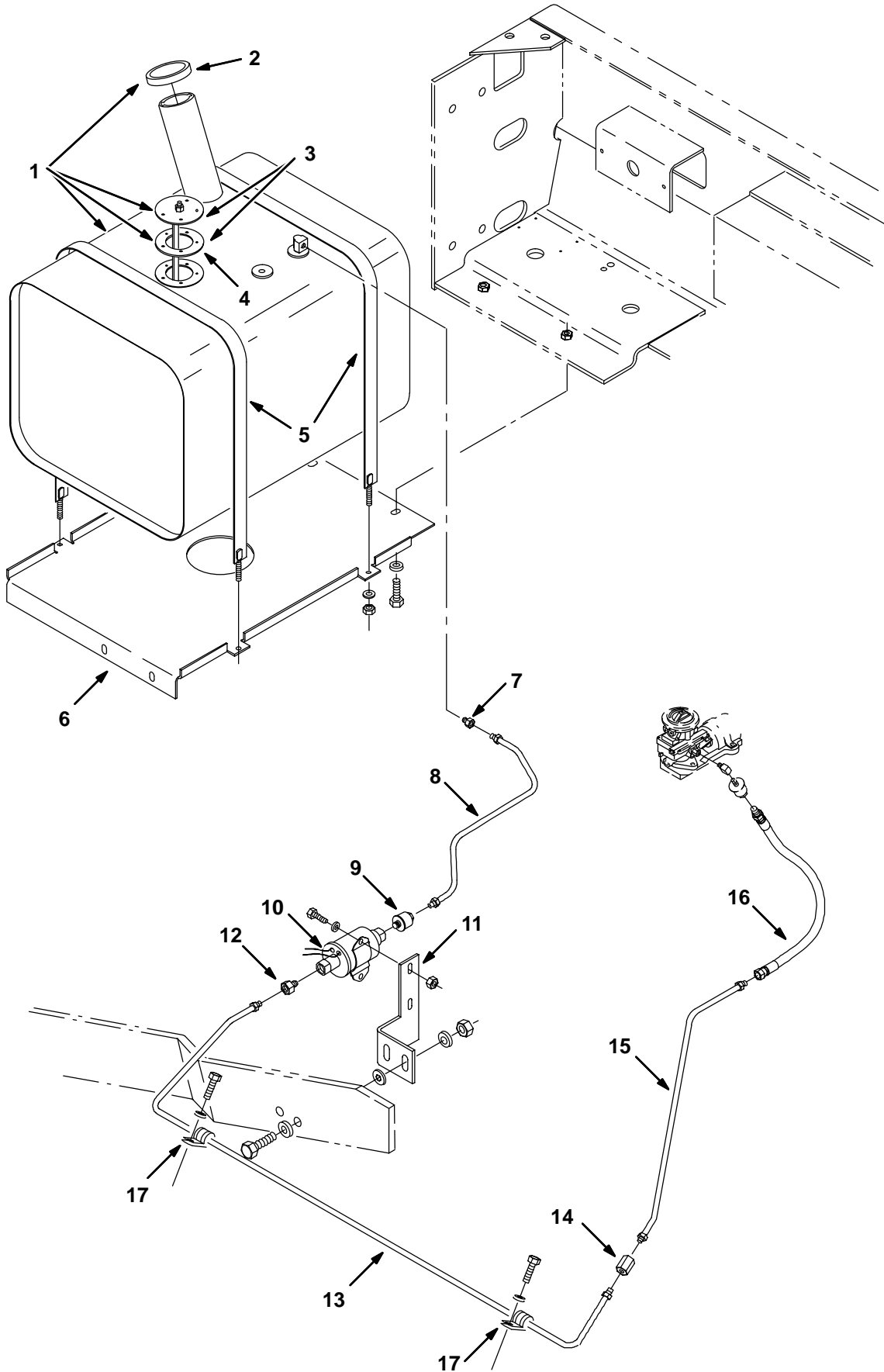

Fig. 48 – Fuel Tank Group, Gas

	Ref.	Tenant Part No.	Machine Serial Number	Description	Qty.
∇	1	76907	(001700–)	Tank, Fuel	1
	2	48267	(001700–)	Cap, Fuel	1
∇	3	07873	(001700–)	Send Unit	1
	4	14131	(001700–)	Gasket, 2.7D 1.5B.12T 5/ 2.1Bc	1
	5	87396	(001700–)	Strap Weldmt, Gas Tank	2
	6	70477	(001700–)	Plate, Mounting, Tank, Gas	1
	7	78043	(001700–)	Fitting–Brs Str	1
	8	77558	(001700–)	Fuelline, .312 Od	1
	9	36050	(001700–)	Filter, Fuel	1
	10	59015	(001700–)	Pump, Fuel	1
	11	75854	(001700–)	Bracket, Pump, Fuel	1
	12	40585	(001700–)	Ftg–Brs Str lf05/Pm02	1
	13	83644	(001700–)	Fuelline, .312 Od	1
	14	25610	(001700–)	Ftg–Brs lf05/lf05	1
	15	83643	(001700–)	Tube Assy, Fuel .31Od	1
	16	70173	(001700–)	Hose, Fuelline, 10.0L	1
	17	76736	(001700–)	Clamp–Cable, 0.38Dia 0.62Wth	2

Fig. 49 – Fuel Tank Group, LPG

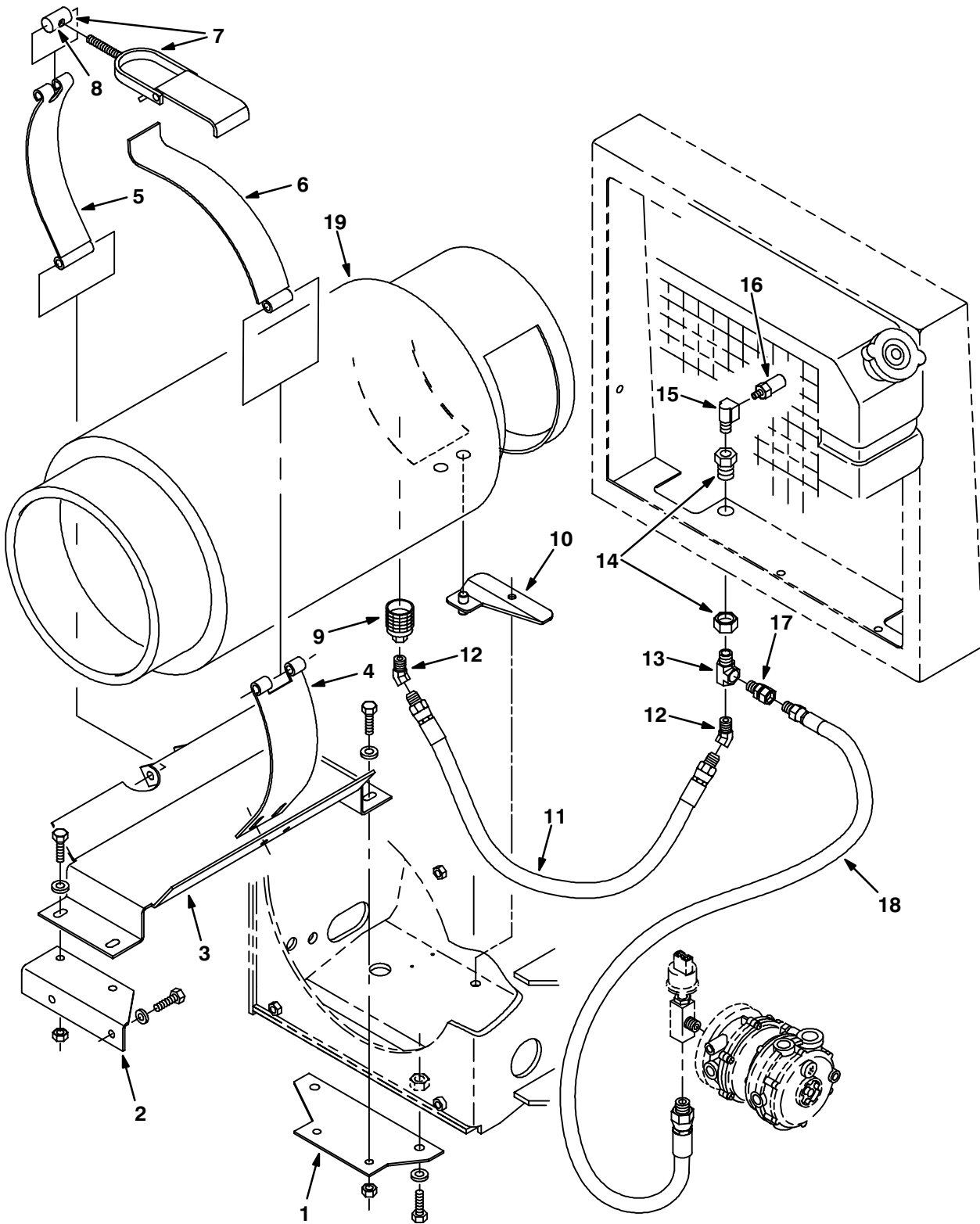

Fig. 49 – Fuel Tank Group, LPG

Ref.	Tenant Part No.	Machine Serial Number	Description	Qty.
1	70718	(000000–)	Plate, Mtg	1
2	70719	(000000–)	Angle, Mtg	1
3	70435	(000000–)	Bracket Wldt, Tank, Lpg	1
4	58589	(000000–)	Strap, Mtg.– Lp Tank	1
5	58590	(000000–)	Strap, Tank Retainer – Lp	1
6	57297	(000000–)	Strap, Hinge – Lp Tank Mtg	1
∇ 7	53400–1	(000000–)	Latch Assy, Lpg Tank Mtg,W/Nut	1
8	53400–4	(000000–)	Nut, Adjustable, Lpg Tank Mtg	1
9	26496	(000000–)	Coupling,Quickdisc, Lpg, Shwd	1
10	74089	(000000–)	Plate Wldt.	1
11	22308–3	(000000–)	Hose, Lpg, 4Lpg X 35.0Lg	1
12	47720	(000000–)	Ftg–Hyd E45 Pm04/Pf04	2
13	56976A	(000000–)	Ftg–Tee Npt 04Pm– 04Pf– 04Pf	1
14	78122	(000000–)	Ftg,Bulkhead .25Npt Wh W21204	1
15	27048	(000000–)	Ftg–EI90 Npt/Npt 04Pf/04Pm	1
16	24047	(000000–)	Valve, Press Relief, Lpg Rego	1
17	11442–23	(000000–)	Ftg–Str Npt/Npt S04Pf–04Pm	1
18	47395	(000000–)	Hose, Lpg, 4Lpg X 40.0Lg	1
19	24928–1	(000000–)	Tank–Lp, 33#,Liq,Both,Fill Ga	1

Fig. 50 – Radiator Hose Group

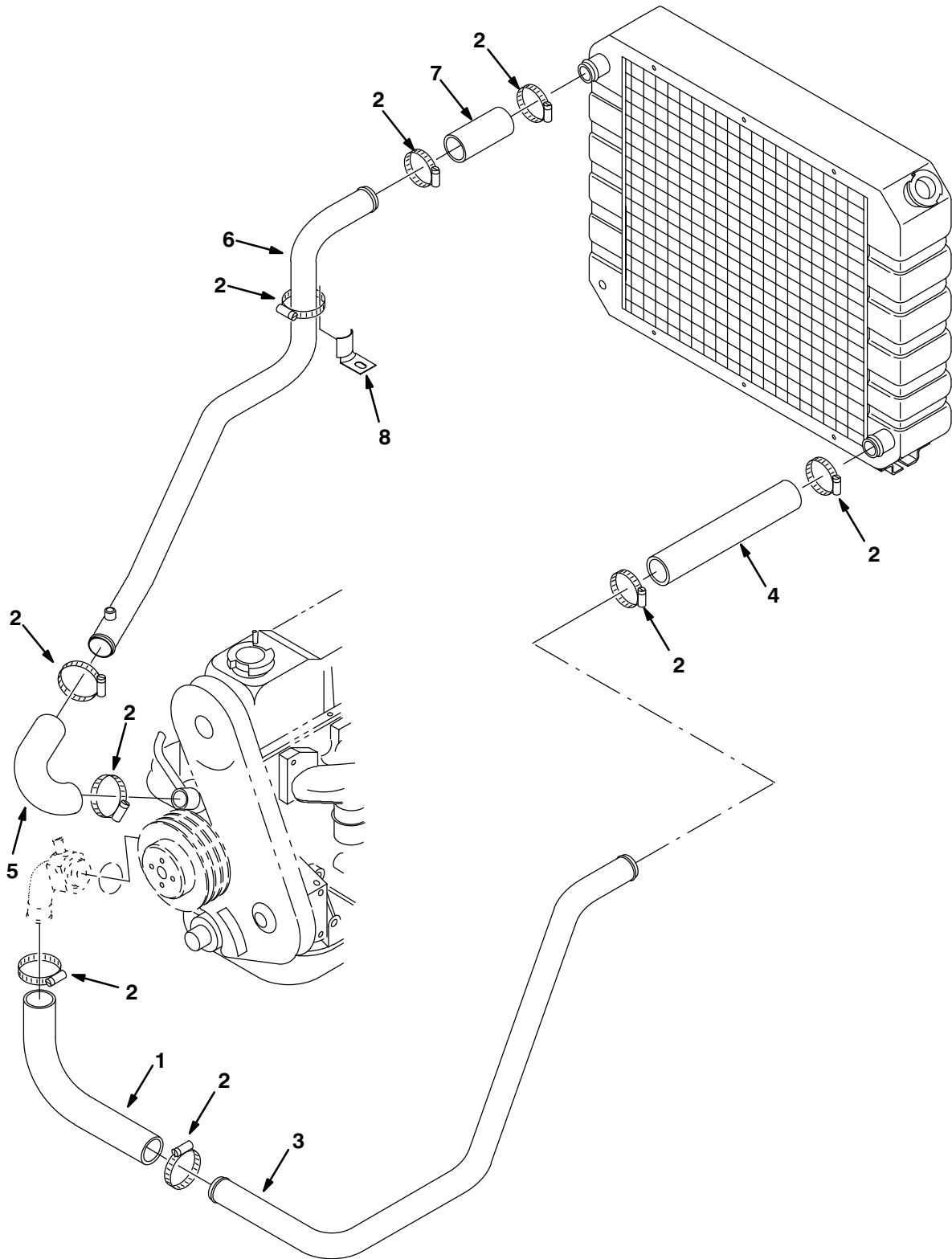

Fig. 50 – Radiator Hose Group

Ref.	Tennant Part No.	Machine Serial Number	Description	Qty.
1	70633	(000000–001699)	Hose, Radiator, Lower	1
1	83690	(001700–)	Hose, Radiator, Lower	1
2	11531	(000000–)	Clamp–Wormdrive, 1.06– 2.00D	9
3	70754	(000000–)	Tube, Radiator, Lower, Gas/Lpg	1
4	70635	(000000–)	Hose, Radiator, Lower	1
5	70636	(000000–)	Hose, Radiator, Upper	1
6	70755	(000000–001699)	Tube, Radiator, Upper, Gas/Lpg	1
6	83691	(001700–)	Tube, Radiator, Upper, Gas/Lpg	1
7	74944	(000000–)	Coupling, Hose	1
8	74058	(000000–)	Bracket	1

Fig. 51 – Radiator Group

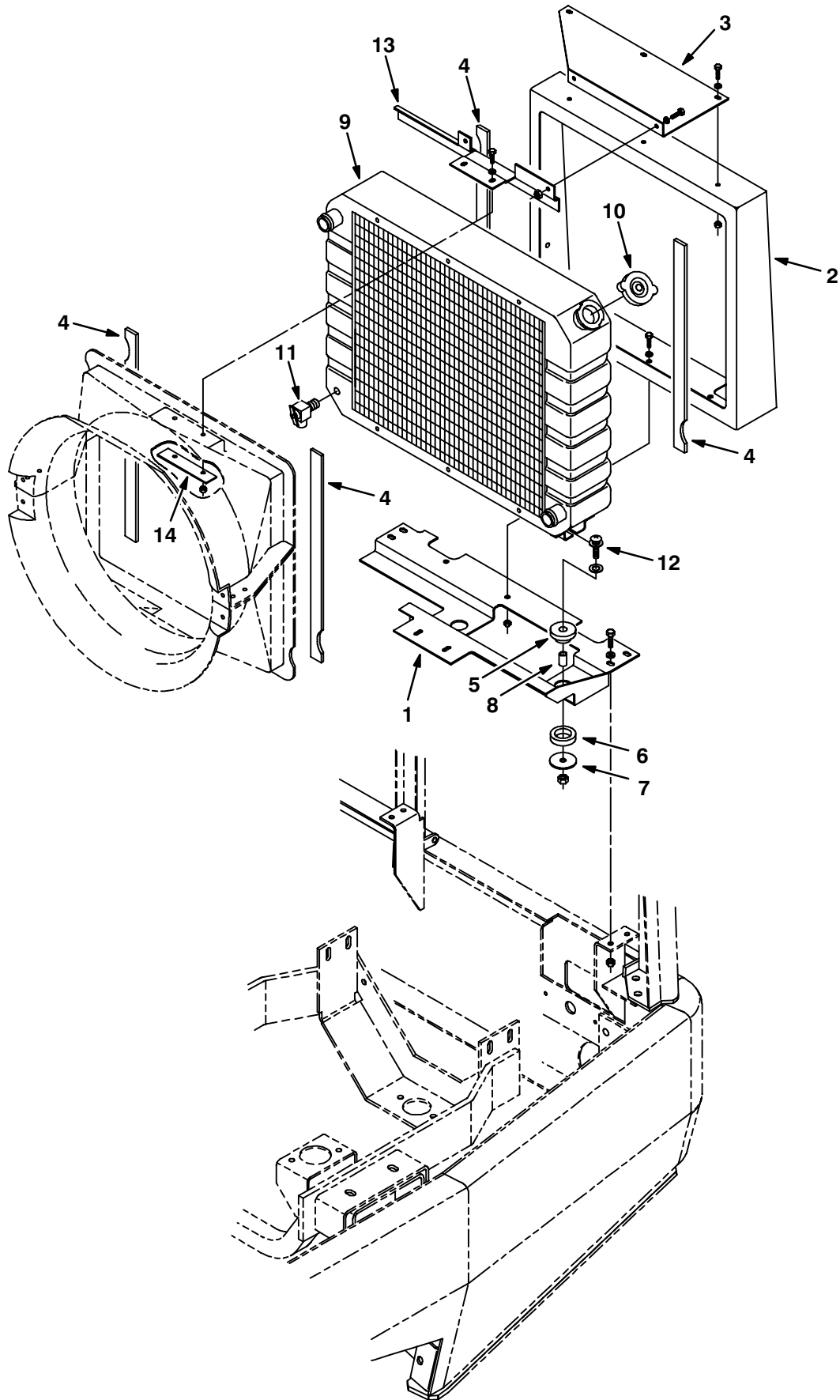

Fig. 51 – Radiator Group

Ref.	Tennant Part No.	Machine Serial Number	Description	Qty.
1	70744	(000000-001223)	Channel Wldt	1
2	64406	(000000-001223)	Duct, Rear	1
3	70710	(000000-001223)	Angle, Top	1
4	63818	(000000-001223)	Seal, Duct	4
5	64621	(000000-001223)	Bushing, Isolator	2
6	64618	(000000-001223)	Ring, Isolator, Outer, Rbr	2
7	58228	(000000-001223)	Plate, Spring, Side Brush	2
8	64299	(000000-001223)	Spacer	2
∇ 9	63191	(000000-001223)	Radiator	1
10	31755	(000000-001223)	Cap, Radiator 7 Psi	1
11	51305	(000000-001223)	Drain Cock,.25Npt Wh#120 Angl	1
12	19577	(000000-001223)	Bolt Carr.38-16X2.00	2
13	70711	(000000-001223)	Angle, Stiffener	1
14	70712	(000000-001223)	Plate, Backing	1

Fig. 52 – Radiator Group

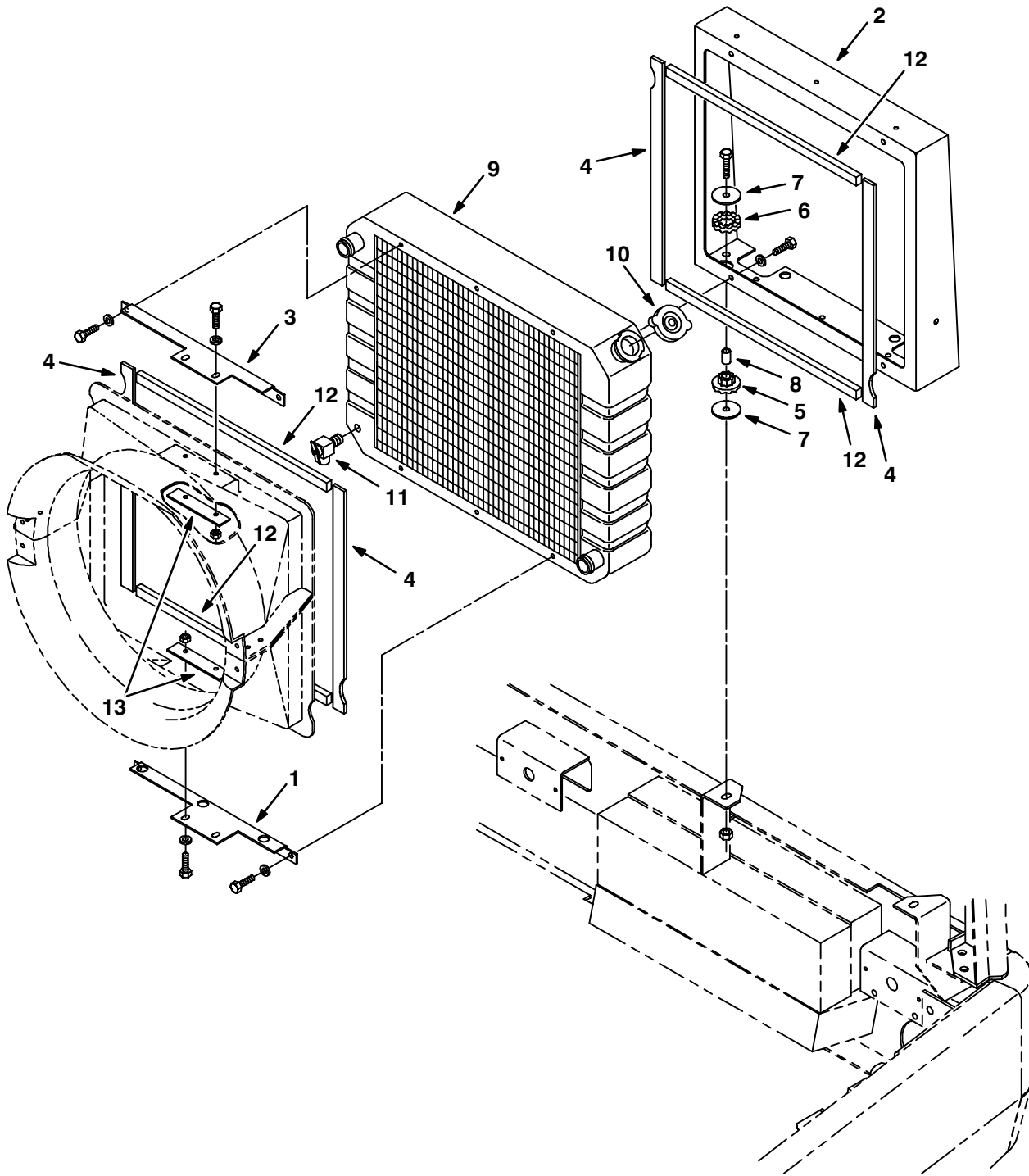

Fig. 52 – Radiator Group

Ref.	Tenant Part No.	Machine Serial Number	Description	Qty.
1	77529	(001224–) Bracket, Mtg, Shroud, Lower	1
2	77447	(001224–) Duct, Rear	1
3	77528	(001224–) Bracket, Mtg, Shroud, Upper	1
4	63818	(001224–) Seal, Duct	4
5	64621	(001224–) Bushing, Isolator	2
6	64618	(001224–) Ring, Isolator, Outer Rbr	2
7	58228	(001224–) Plate, Spring – Side Brush	4
8	77452	(001224–) Spacer	2
9	73140	(001224–) Radiator, 4 Row, 6 Fin	1
10	31755	(001224–) Cap Radiator	1
11	51305	(001224–) Drain Cock,.25Npt Wh#120 Angl	1
12	59734	(001224–) Seal, Fan, Vac Outlet	4
13	70712	(001224–) Plate, Backing	2

Fig. 53 – Cooling Fan and Housing Group

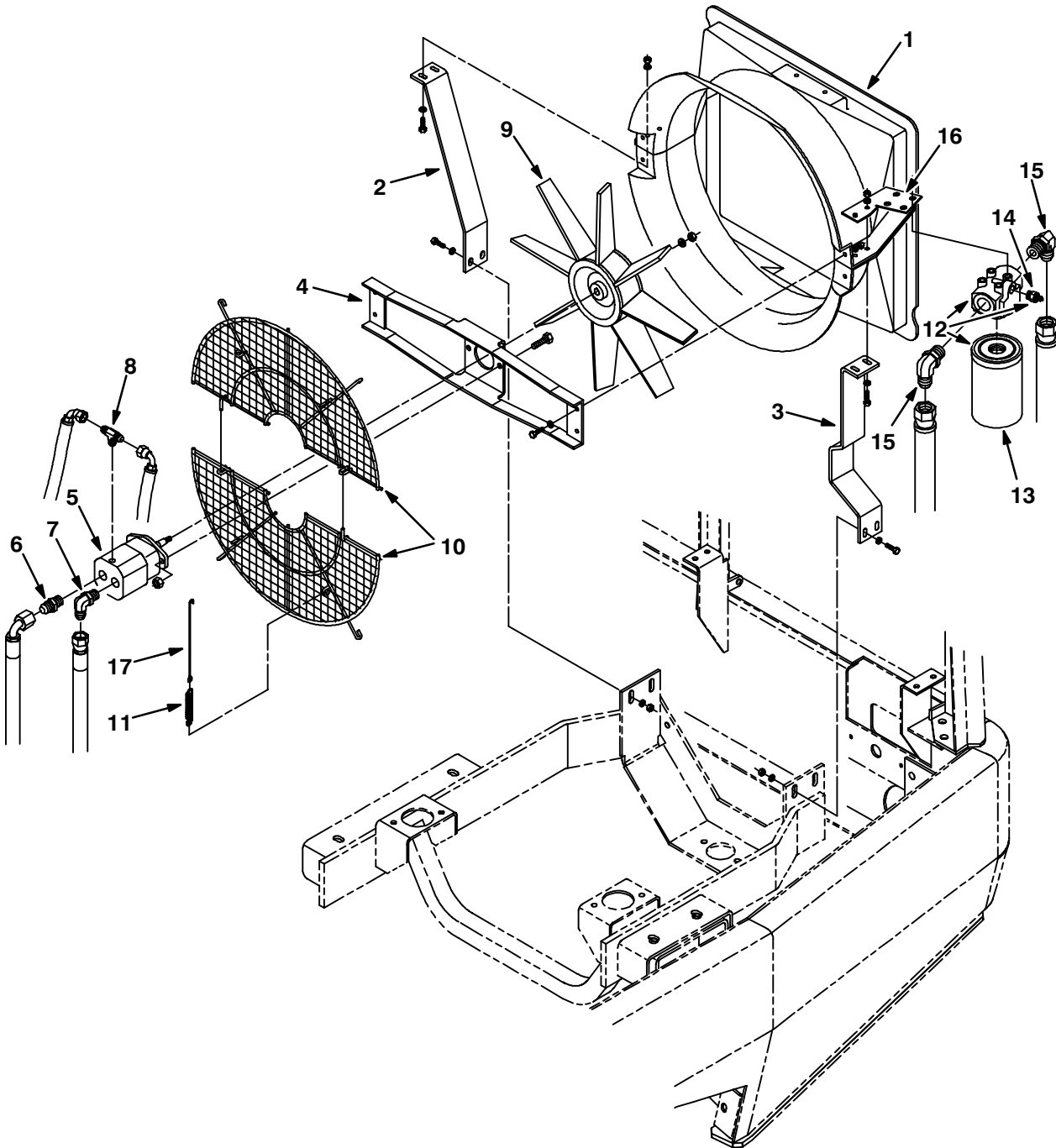

Fig. 53 – Cooling Fan and Housing Group

Ref.	Tenant Part No.	Machine Serial Number	Description	Qty.
1	63279	(000000–001229)	Panel Wldt, Transition, Fan	1
2	63599	(000000–001223)	Angle, Mtg, Shroud, Rh	1
3	70858	(000000–001223)	Angle, Mtg, Shroud, Lh	1
4	70703	(000000–001229)	Channel Wldt, Fan Motor	1
5	63542	(000000–001229)	Motor–Hyd Gear In 10.0 (See Breakdowns)	1
6	52402	(000000–001229)	Ftg–Hyd Str Jm06/Om08	1
7	47512	(000000–001229)	Ftg–Hyd E90 Jm06/Om08	1
8	31599	(000000–001229)	Ftg–Hyd Tee Jm04Omjm	1
9	63280	(000000–001229)	Fan, Radiator	1
10	70461	(000000–001229)	Screen, Guard	2
11	57792	(000000–001229)	Spring, Tension	2
∇ 12	65220	(000000–001229)	Filter Assy, Spin–On 10Micron	1
13	65221	(000000–001229)	Filter Element Dn	1
14	65222	(000000–001229)	Filter Sender Dn	1
15	46481	(000000–001229)	Ftg–Hyd E90 Jm12/Om12	2
16	70859	(000000–001223)	Bracket, Mtg, Filter	1
17	74042	(000000–001229)	Hook	2

Fig. 54 – Cooling Fan and Housing Group

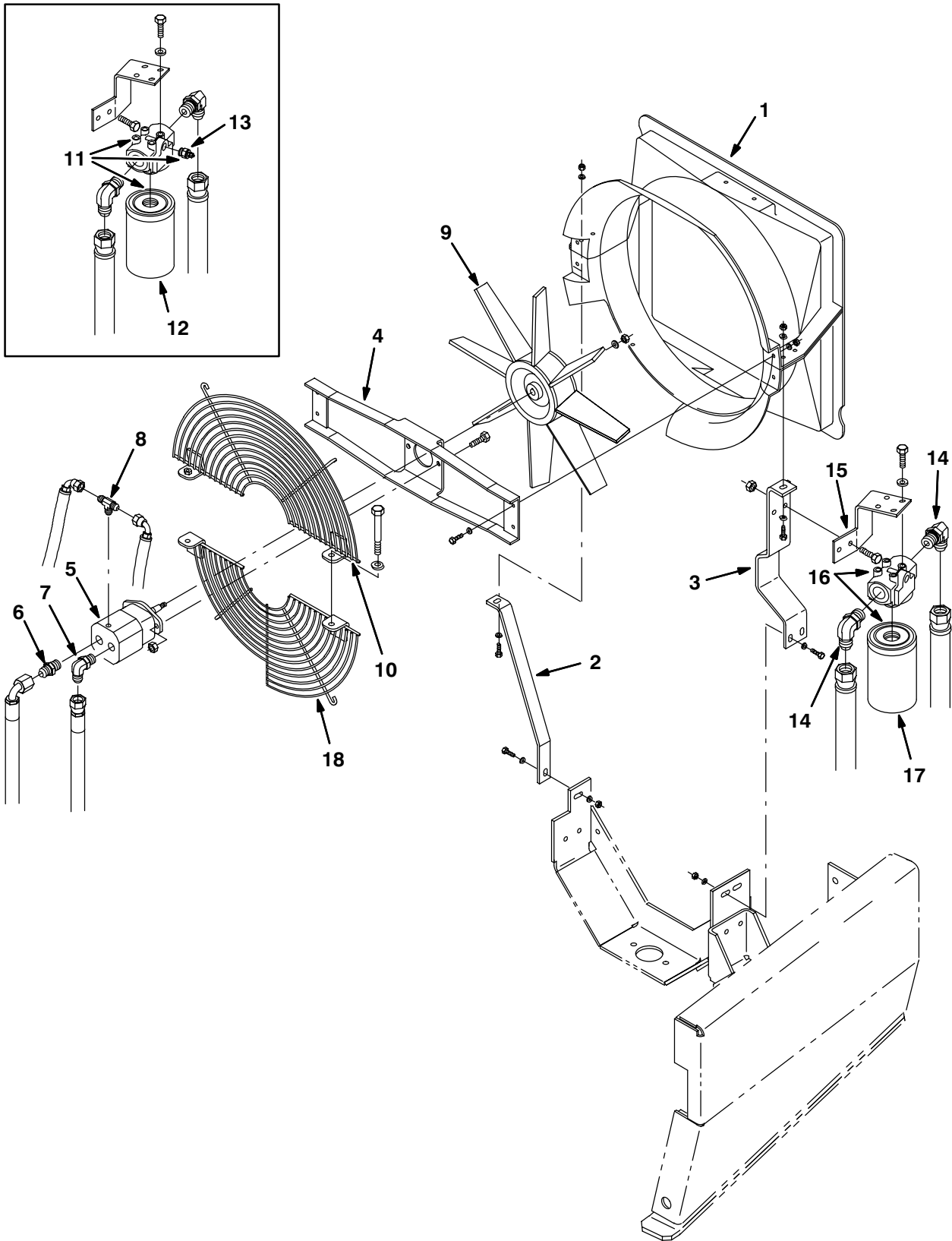
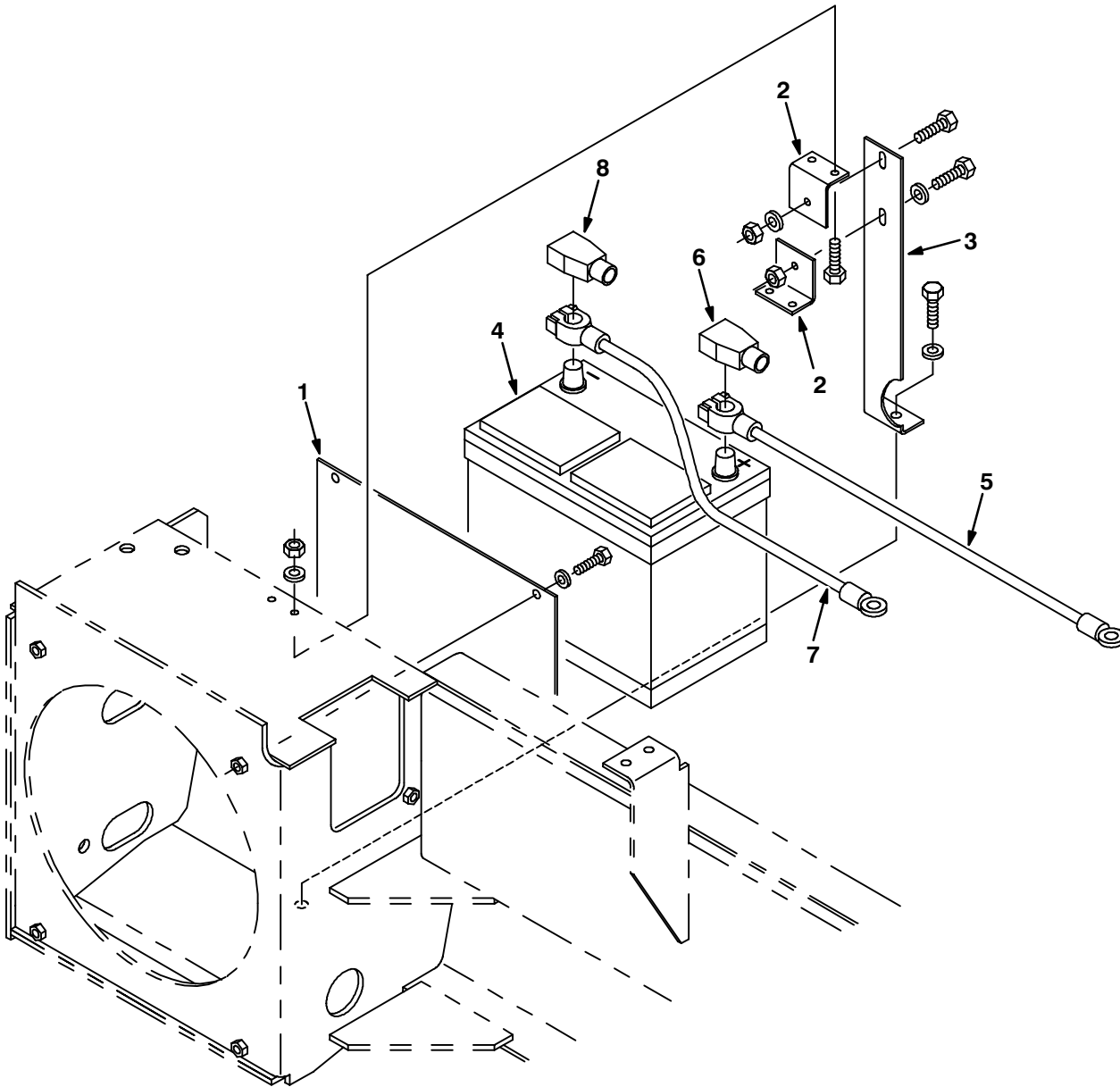

Fig. 54 – Cooling Fan and Housing Group

Ref.	Tennant Part No.	Machine Serial Number	Description	Qty.
1	63279	(001230–)	Panel, Transition, Fan	1
2	21689	(001224–)	Bracket, Mtg, Shroud, Rh	1
3	77527	(001224–)	Bracket, Mtg, Shroud, Lh	1
4	70703	(001230–)	Channel Wldt, Fan Motor	1
5	63542	(001230–)	Motor–Hyd, Gear In 10.0 (See Breakdowns)	1
6	52402	(001230–)	Ftg–Hyd Str Jm06/Om08	1
7	47512	(001230–)	Ftg–Hyd E90 Jm06/Om08	1
8	31599	(001230–)	Ftg–Hyd Tee Jm04Omjm	1
9	63280	(001230–)	Fan, Radiator	1
10	77788	(001230–)	Screen, Guard	1
∇ 11	10665	(001230–001405)	Filter Assy, Replmt Kit F/65220	1
12	65221	(001230–001405)	Element, Filter	1
13	65222	(001230–001405)	Sender, Filter, Hydraulic	1
14	46481	(001230–)	Ftg–Hyd E90 Jm12/Om12	2
15	77530	(001224–)	Bracket, Mounting Filter	1
∇ 16	10664	(001406–)	Filter Assy, Spin–On	1
17	65221	(001406–)	Element, Filter	1
18	21695	(001230–)	Screen, Guard, Lower	1

Fig. 55 – Battery Group, Gasoline



07732/07733

Ref.	Tennant Part No.	Machine Serial Number	Description	Qty.
1	70540	(000000-001211)	Plate	1
2	70539	(000000-001211)	Bracket	2
3	70541	(000000-001211)	Bracket	1
4	10143	(000000-001211)	Battery, 12V, Cc Amps:600 Wet	1
5	60292	(000000-001211)	Wire Assy, 66.0 Lg, 2 Ga, Pos	1
6	68873	(000000-001211)	Boot,Batt.Term. 1-2Ga. Red	1
7	60293	(000000-001211)	Wire Assy, 42.0 Lg, 2 Ga, Neg	1
8	68872	(000000-001211)	Boot,Batt.Term.1-2Ga. Black	1

Fig. 56 – Battery Group, LPG

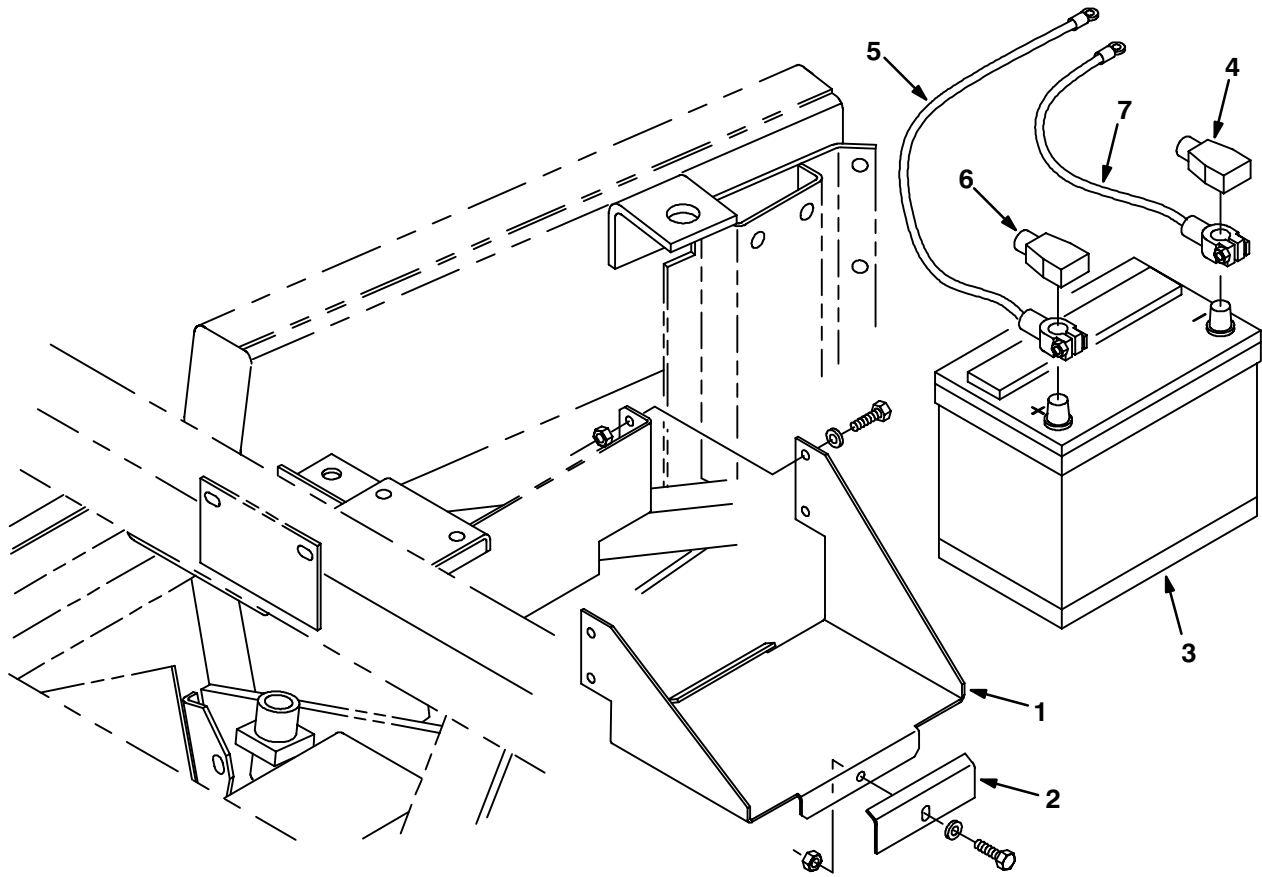

07726/07727

Ref.	Tennant Part No.	Machine Serial Number	Description	Qty.
1	70666	(000000-001211)	Bracket, Mtg, Battery	1
2	70708	(000000-001211)	Bracket, Battery	1
3	10143	(000000-001211)	Battery, 12V, Cc Amps:600 Wet	1
4	68872	(000000-001211)	Boot,Batt.Term.1-2Ga. Black	1
5	60292	(000000-001211)	Wire Assy, 66.0 Lg, 2 Ga, Pos	1
6	68873	(000000-001211)	Boot,Batt.Term. 1-2Ga. Red	1
7	60293	(000000-001211)	Wire Assy, 42.0 Lg, 2 Ga, Neg	1

Fig. 57 – Battery Group, Gasoline and LPG

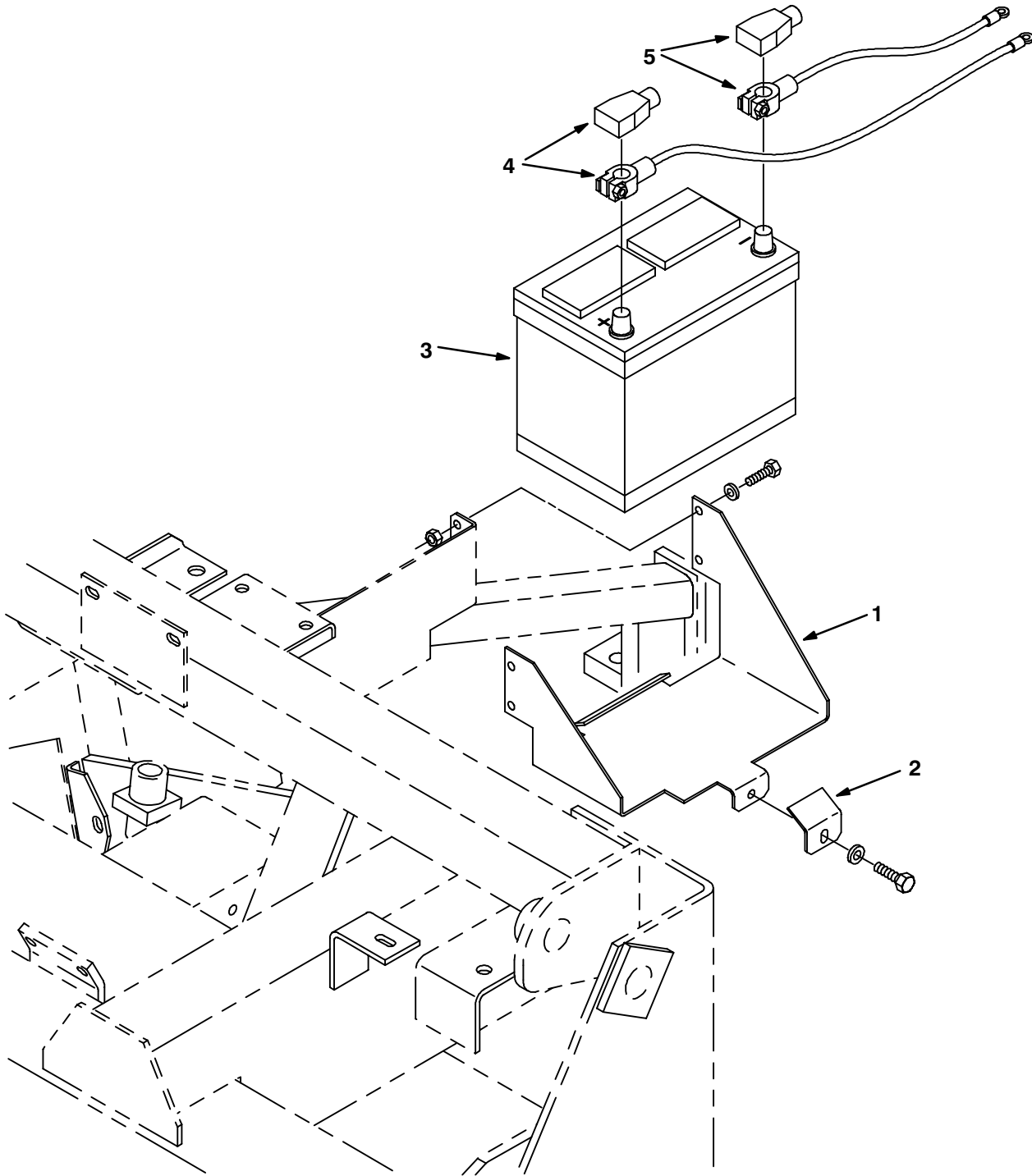

Fig. 57 – Battery Group, Gasoline and LPG

Ref.	Tenant Part No.	Machine Serial Number	Description	Qty.
1	77490	(001212–) Bracket, Mtg, Battery	1
2	77579	(001212–) Bracket, Battery	1
3	77602	(001212–) Battery, 12V, Wet	1
4	68869	(001212–) Cable Assy–Batt,Pos, 48.0, 2Ga	1
5	60293	(001212–) Wire, 42.0 Lg, 2Ga, Neg	1

Fig. 58 – Rear Wheel Drive Group

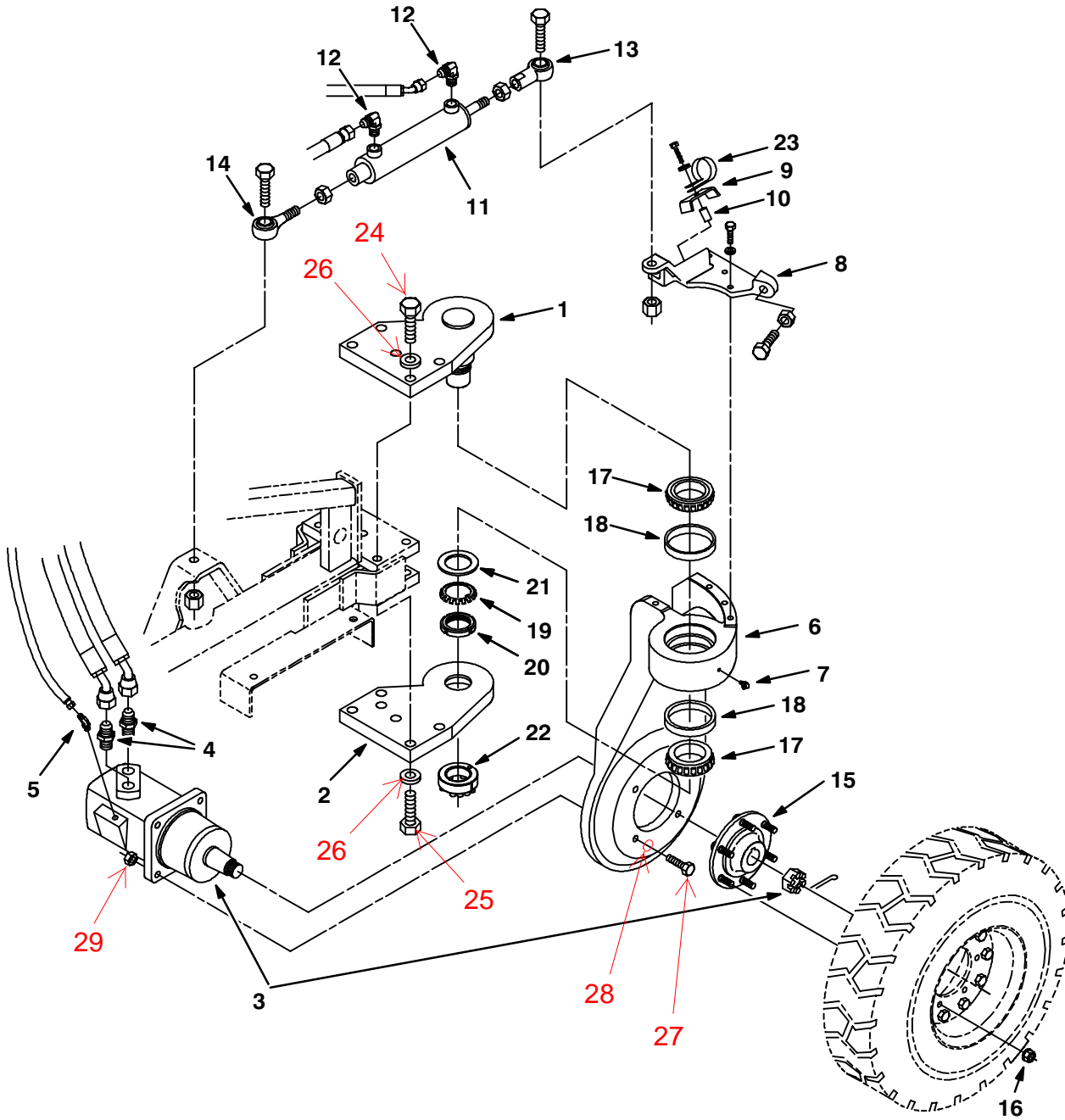

Fig. 58 – Rear Wheel Drive Group

Ref.	Tennant Part No.	Machine Serial Number	Description	Qty.
1	63491	(000000–)	Pivot Wldt, Wheel	1
2	63471	(000000–)	Plate, Pivot, Wheel	1
3	63426	(000000–)	Motor–Hyd Gear In (See Breakdowns)	1
4	67310	(000000–)	Ftg–Hyd Str Jm12/Om16	2
5	34359	(000000–)	Ftg–Hyd E45 Jm04/Om04	1
6	63540	(000000–)	Housing, Sppt, Wheel	1
7	09718	(000000–)	Ftg, Grease.25–28Th 90 .75L	1
8	63543	(000000–)	Bracket, Steering, Machining	1
9	73733	(000000–)	Channel, Retainer	1
10	73731	(000000–)	Sleeve, .375B .62D1.06 Stl	1
11	53601	(000000–)	Cylinder, Hyd (See Breakdowns)	1
12	56820	(000000–)	Ftg–Hyd E90 Jm06/Om06	2
13	64887	(000000–)	Balljoint, Rod End	1
14	64886	(000000–)	Balljoint, Rod End	1
15	63591	(000000–001258)	Housing Assy, Rear Hub	1
15	79140	(001259–)	Hub and Stud Assy.	1
16	78999	(000000–001258)	Nut, Wheel Lug	6
16	79153	(001259–)	Nut, Wheel Lug	6
17	51341	(000000–)	Bearing–Cone, 2.63Bore 0.87Wth	2
18	51340	(000000–)	Bearing–Cup , 4.33Dia 0.74Wth	2
19	41074	(000000–)	Washer,Lock Special	1
20	41073	(000000–)	Nut,Lock–Special 2.16–18Uns	1
21	79514	(000000–)	Washer	1
22	63496	(000000–)	Ring, Retainer, Lock	1
23	67767	(000000–)	Clamp, Cable	1
24	06995		Scr, Hex M20 x 2.5 x 70	3
25	06993		Scr, Hex M20 x 2.5 x 60	7
26	39350		Washer, Flt	10
27	39305		Bolt	4
28	32486		Washer	4
29	32985		Nuts	4

Fig. 59 – Front Wheels and Brakes Group

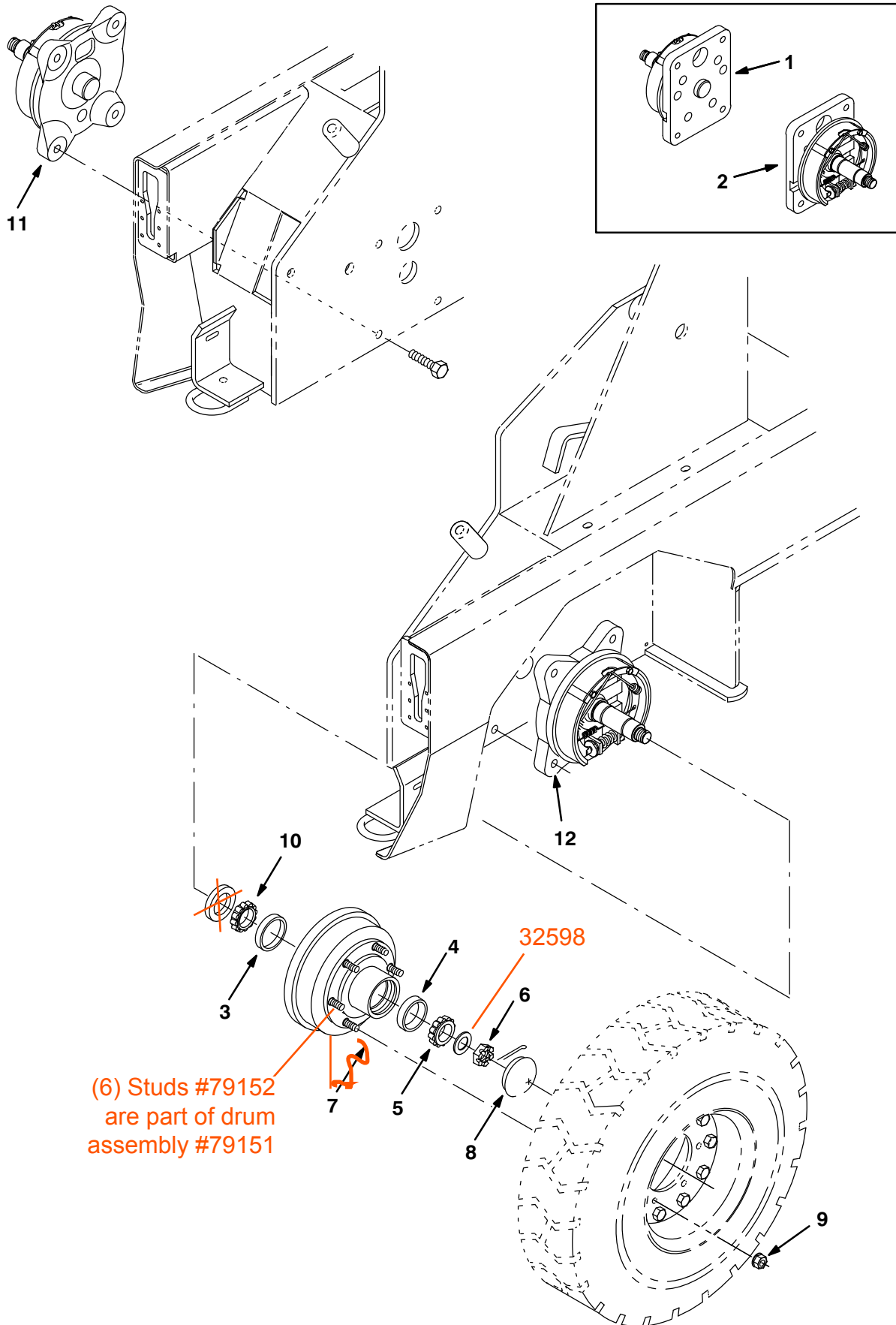

Fig. 59 – Front Wheels and Brakes Group

Ref.	Tennant Part No.	Machine Serial Number	Description	Qty.
1	63290	(000000–001354)	Brake, Hyd, Rh (Repl. by 77790)	1
2	63286	(000000–001354)	Brake, Hyd, Lh (Repl. by 77770)	1
3	17808	(000000–)	Bearing–Cup, 2.72Dia 0.59Wth	2
4	51338	(000000–)	Bearing–Cup, 2.56Dia 0.55Wth	2
5	51193	(000000–)	Bearing–Cone, 1.38Bore 0.72Wth	2
6	14242	(000000–)	Nut–Hxslot 1.00–20 Pltd	2
7	63281	(000000–001258)	Drum, Brake	2
7	79151	(001259–)	Drum Assy, Brake 9/16	2
8	51373	(000000–)	Cap, Grease Black Paint	2
9	78999	(000000–001258)	Nut–Wheel .50–20	12
9	79153	(001259–)	Nut, Wheel Lug, 9/16–18	12
10	17809	(000000–)	Bearing–Cone, 1.50Bore 0.75Wth	2
11	77790	(001355–)	Brake Assy, Rh	1
12	77770	(001355–)	Brake Assy, Lh	1

Fig. 60 – Wheel Assembly

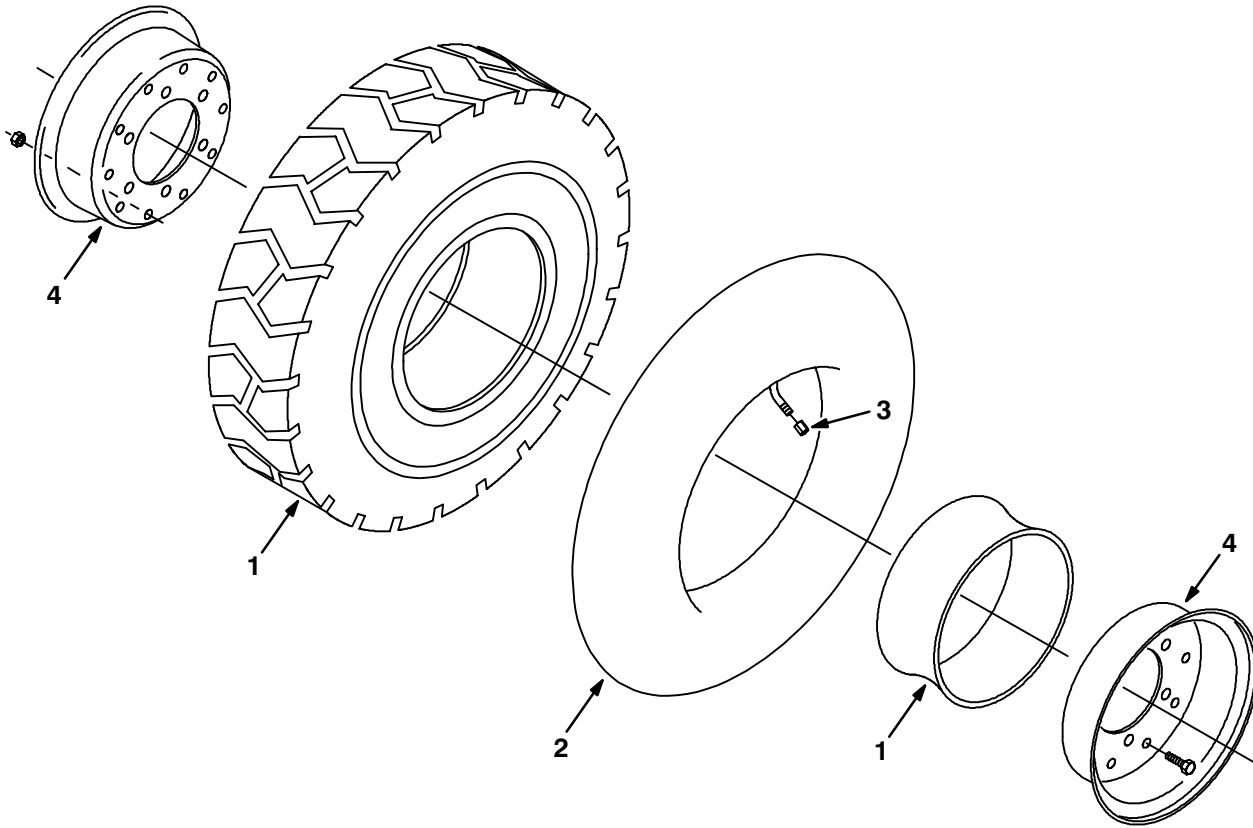

Fig. 60 – Wheel Assembly

Ref.	Tennant Part No.	Machine Serial Number	Description	Qty.
∇	63850	(000000–) Tire & Rim Assy, Pneu 6.50–10	3
1	64059	(000000–) Tire & Flap Assy	1
2	64058	(000000–) Tube, Inner	1
3	45786	(000000–) Cap, Valve Stem	1
4	63218	(000000–) Hub Assy	1

Fig. 61 – Brake Pedals Group

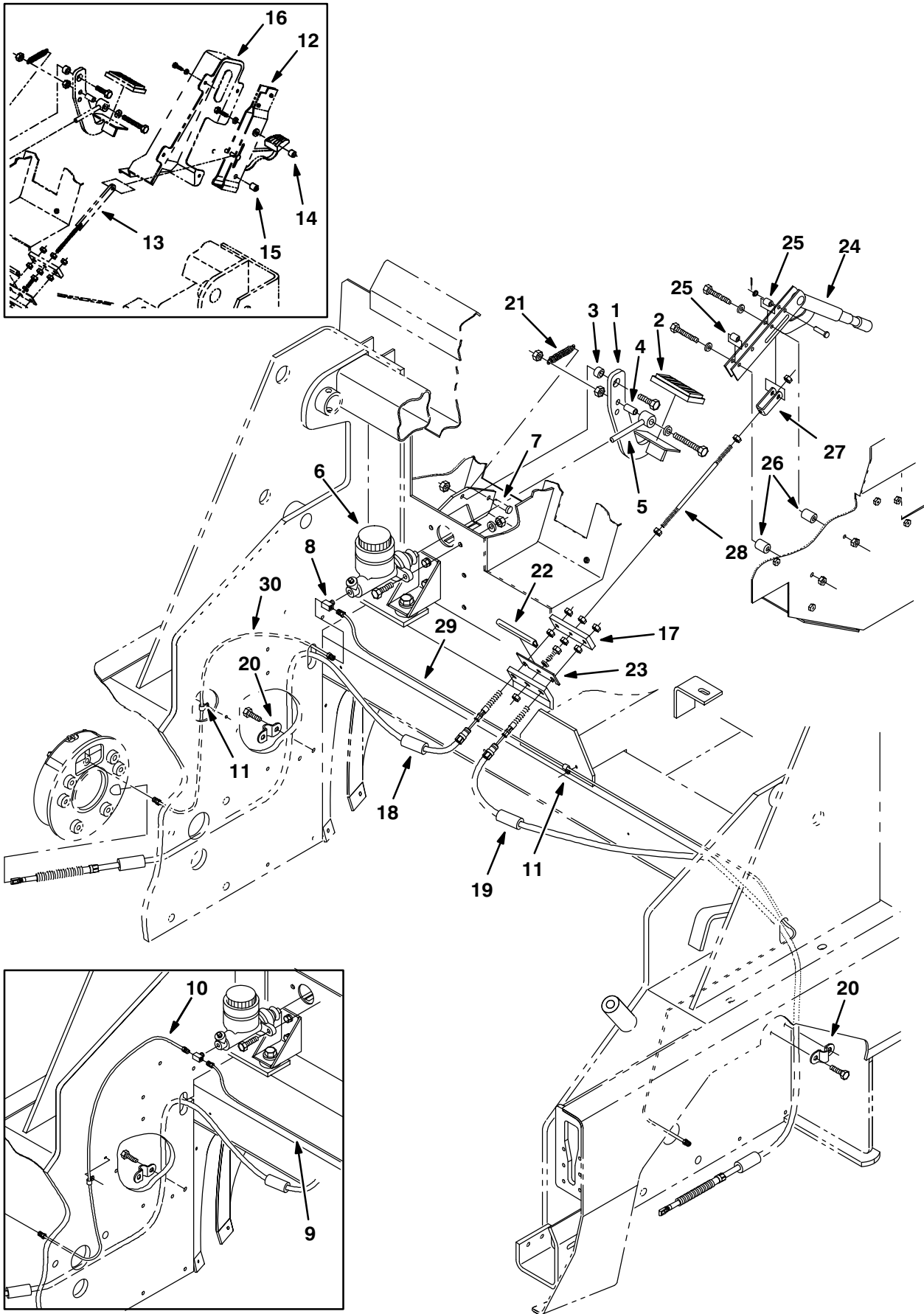

Fig. 61 – Brake Pedals Group

Ref.	Tennant Part No.	Machine Serial Number	Description	Qty.
1	63295	(000000–)	Pedal Wldt	1
2	51109	(000000–)	Pad	1
3	64635	(000000–)	Spacer	1
4	57311	(000000–)	Spacer–.50 Od X .055W X 1.0	1
5	70550	(000000–)	Rod Wldt, Push, Brake	1
6	64950	(000000–)	Cylinder, Master Brake	1
7	76653	(000000–)	Pin, Clevis .375D X 1.000 Lg	1
8	51483	(000000–)	Ftg,Brass,Tee 06lf– 02Pm– 06lf	1
9	64554	(000000–001354)	Tube Assy, Brake,Metric 80.0Lg	1
10	64550	(000000–001354)	Tube Assy, Brake,Metric 34.0Lg	1
11	46236	(000000–)	Clamp–Cable, 0.25Dia 0.56Wth	5
12	77646	(000000–001102)	Brake, Hand, Replmt Kit	1
13	70511	(000000–001102)	Rod Wldt, Adjustment	1
14	70505	(000000–001102)	Sleeve, .380B .62D .50 Smls	1
15	70504	(000000–001102)	Sleeve, .380B .62D .66 Smls	1
16	76639	(000000–001102)	Cover, Brake Kit	1
17	70506	(000000–)	Bar, Equalizer	1
18	64556	(000000–)	Cable, Brake, Park	1
19	64558	(000000–)	Cable, Brake, Park	1
20	65129	(000000–)	Clamp, Cable– Brake	2
21	75575	(000000–)	Spring, Tens,0.5Dx.06Wire 2.5L	1
22	31775	(000000–)	Molding, Trim 11–14Ga 4.0	1
23	74022	(000000–)	Strip, Retainer, Brake Cable	1
24	51545	(001103–)	Lever, Brake	1
25	51562	(001103–)	Sleeve, .344B .50D .81 Cr.Anc	2
26	86034	(001103–)	Spacer, Brake	2
27	76491	(001103–)	Bracket, Adjuster, Brake	1
28	76490	(001103–)	Rod–Thread, 2End M08X1.25X10Lg	1
29	79593	(001355–)	Tube Assy, Brake	1
30	79594	(001355–)	Tube Assy, Brake	1

Fig. 62 – Directional Pedal Group

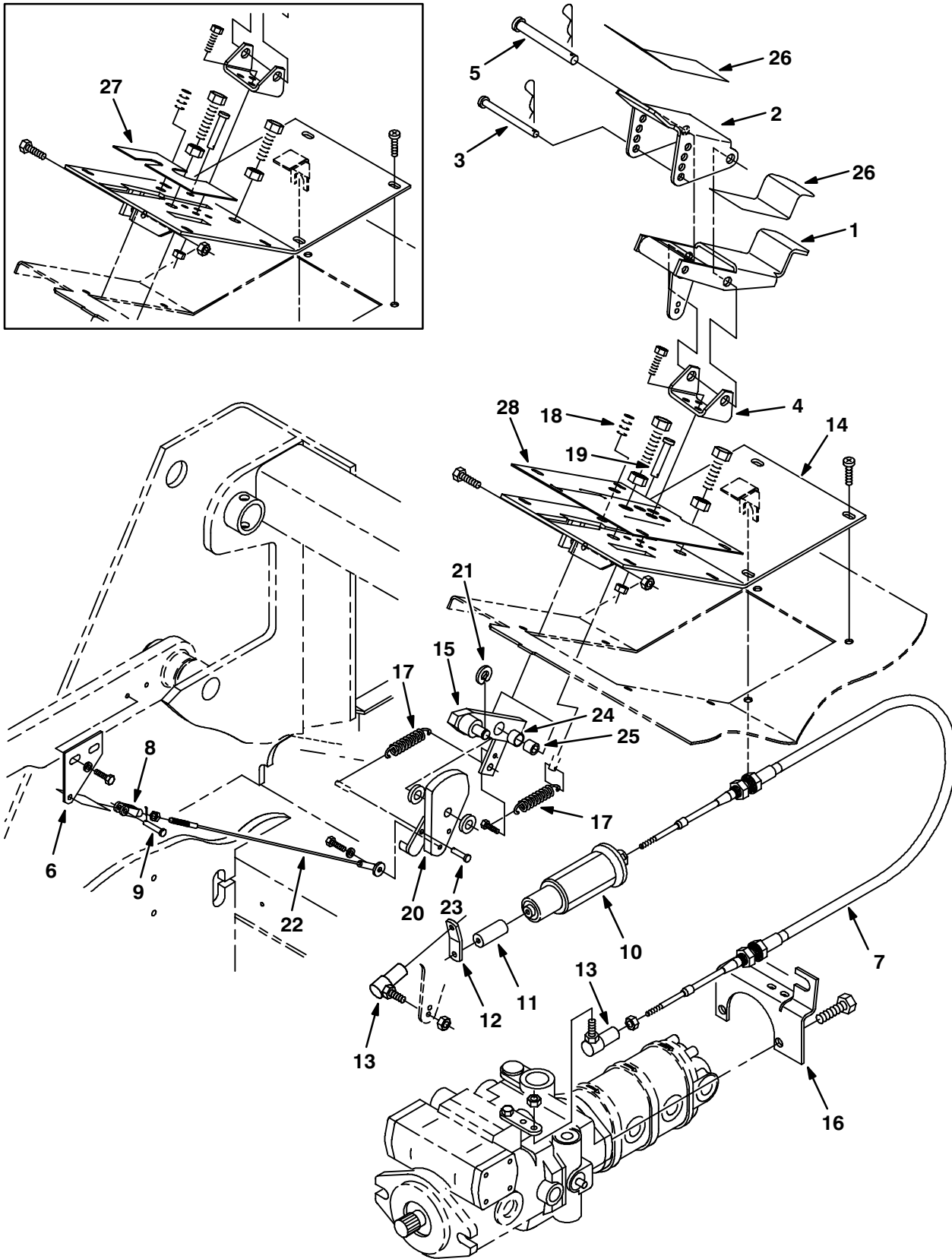

Fig. 62 – Directional Pedal Group

Ref.	Tennant Part No.	Machine Serial Number	Description	Qty.
1	74052	(000000–)	Pedal Wldt, Lower	1
2	75305	(000000–)	Pedal, Upper	1
3	59672	(000000–)	Pin, Clevis .31 Dia X 4.50 Lg	1
4	63275	(000000–)	Bracket, Mounting Dir Cont	1
5	59668	(000000–)	Pin, Clevis .50 Dia X 4.50 Lg	1
6	70725	(000000–)	Plate	1
7	63276	(000000–)	Cable, Push,Pull	1
8	14595–1	(000000–)	Clevis,Adjust.0.25–28Th.Cad.	1
9	14605	(000000–)	Pin,Clevis,0.25 Dia.X 0.75 Lg	1
10	63292	(000000–)	Spring, Propel, Centering	1
11	65246	(000000–)	Spacer	1
12	64632	(000000–)	Bracket, Adjusting, Spring	1
13	14601	(000000–)	Ball Joint, 250–28	2
14	63551	(000000–)	Panel, Access	1
15	70747	(000000–)	Bar Wldt, Pivot	1
16	76427	(000000–)	Bracket, Mounting,Alarm Switch	1
17	54222	(000000–)	Sprng, Tens,1.000dx.09Wire2.8 L	2
18	76523	(000000–)	Screw–Set M10 X 1.50 2045H	1
19	76647	(000000–)	Pin, Clevis .375D X 1.312 Lg	1
20	70783	(000000–)	Cam Wldt	1
21	86953	(000000–)	Ring,Retain,Ex,0.50 Stl Steel	2
22	70749	(000000–)	Cable, Speed Control	1
23	82168	(000000–)	Pin, Clevis .25 Dia, 1.000 Lg.	1
24	07449	(000000–)	Bearing, Fiberglide	1
25	74051	(000000–)	Sleeve, .408B .62D .53Stl	1
26	82839	(000000–)	Pad, Tread	1
27	76453	(000000–001241)	Seal, Rubber, Propel Pedal	1
28	79116	(001242–)	Seal, Dust	1

Fig. 63 – Hydraulic Pumps Group

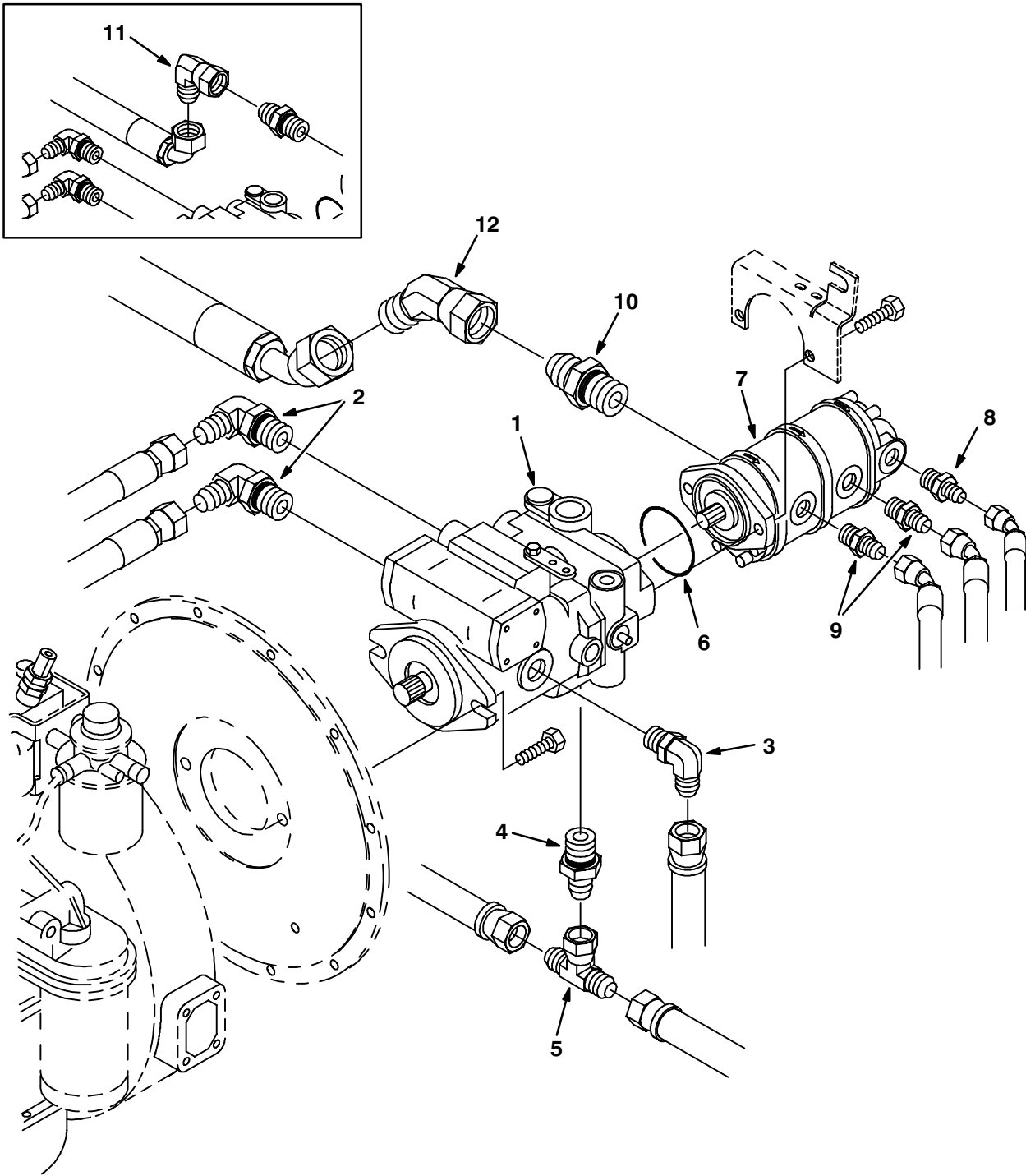

Fig. 63 – Hydraulic Pumps Group

Ref.	Tenant Part No.	Machine Serial Number	Description	Qty.
1	62548	(000000–001164)	Pump–Hyd Piston V (See Breakdowns)	1
1	74163	(001165–)	Pump–Hyd Piston V (See Breakdowns)	1
2	52911	(000000–)	Ftg–Hyd E90 Jm12/Om16	2
3	46481	(000000–)	Ftg–Hyd E90 Jm12/Om12	1
4	67310	(000000–)	Ftg–Hyd Str Jm12/Om16	1
5	62389	(000000–)	Ftg–Hyd Tee Jm12/Jfjm	1
6	65145–1	(000000–)	O–Ring Gland	1
7	62561	(000000–)	Pump–Hyd Gear Ex (See Breakdowns)	1
8	47508	(000000–)	Ftg–Hyd Str Jm06/Om10	1
9	56692	(000000–)	Ftg–Hyd Str Jm08/Om10	2
10	58858	(000000–)	Ftg–Hyd Str Jm20/Om20	1
11	19459	(000000–001050)	Ftg–Hyd E90 Jm20/Jf20	1
12	19544	(001051–)	Ftg–Hyd E45 Jm20/Jf20	1

Fig. 64 – Hydraulic Schematic
(for machines below serial number xxxxxx)

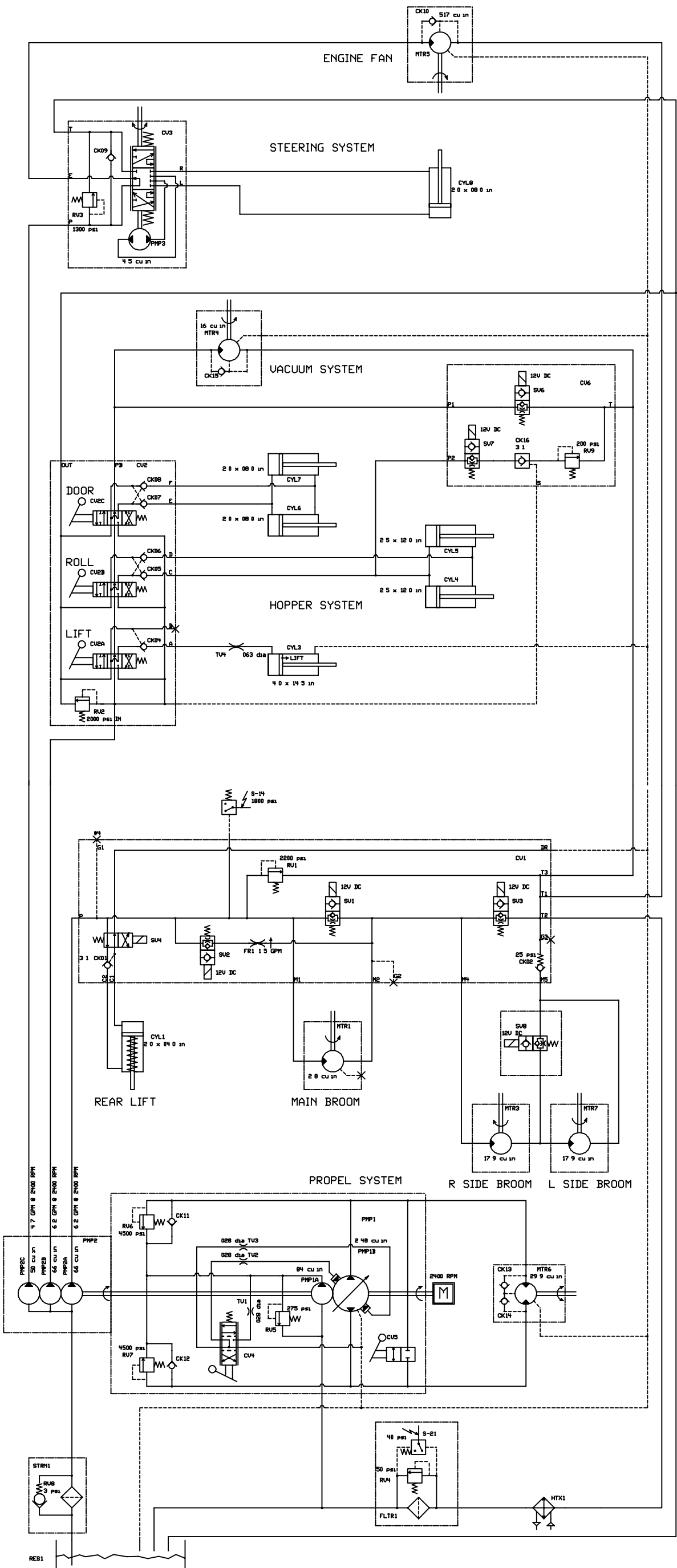

Fig. 65 – Hydraulic Schematic
(for machines serial number xxxxxx and above)

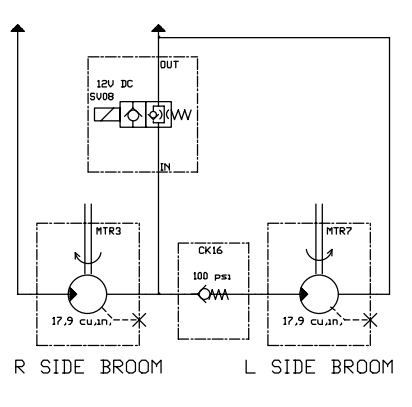
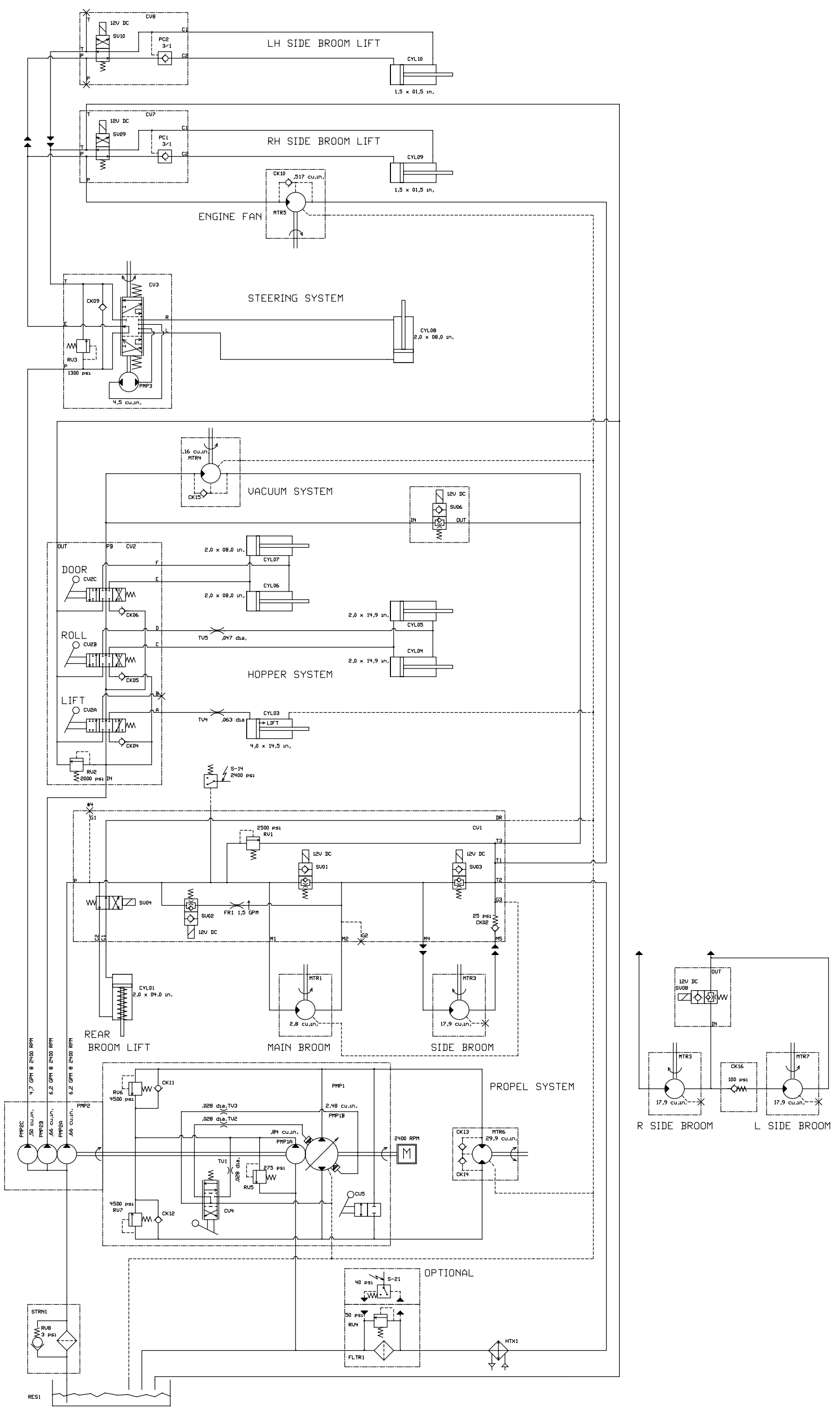

Fig. 66 – Hydraulic Hose Group
(for machines below serial number xxxxxx)

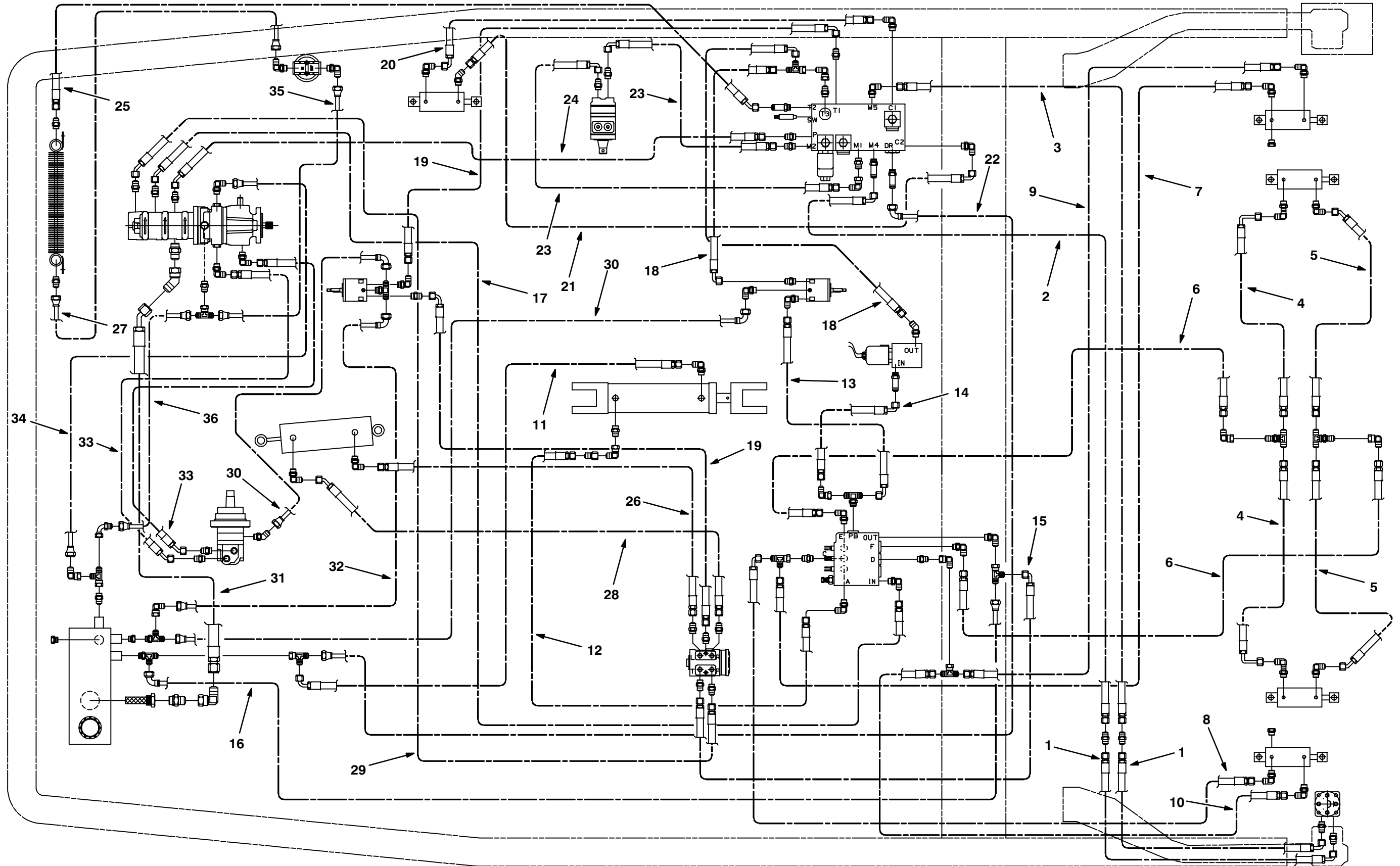

Fig. 66 – Hydraulic Hose Group
(for machines below serial number xxxxxx)

Ref.	Tennant Part No.	Machine Serial Number	Description	Qty.
1	65194	(000000-xxxxxx)	Hose-Hyd Med06 Jf/J9	2
2	65197	(000000-xxxxxx)	Hose-Hyd Med08 Jf/J9	1
3	65224	(000000-xxxxxx)	Hose-Hyd Med08 Jf/Jf	1
4	65188	(000000-xxxxxx)	Hose-Hyd Med04 Jf/J19	2
5	57173	(000000-xxxxxx)	Hose-Hyd Med04 Jf/J4	2
6	76499	(000000-001054)	Hose-Hyd Replm Kit 800/810	2
6	76498	(001055-xxxxxx)	Hose-Hyd Med04 Jf/Jf	2
7	65208	(000000-xxxxxx)	Hose-Hyd Med04 Jf/Jf	1
8	65209	(000000-xxxxxx)	Hose-Hyd Med04 Jf/J9	1
9	65211	(000000-xxxxxx)	Hose-Hyd Med04 Jf/Jf	1
10	65210	(000000-xxxxxx)	Hose-Hyd Med04 Jf/Jf	1
11	71552	(000000-xxxxxx)	Hose-Hyd Med06 Jf/J9	1
12	82814	(000000-xxxxxx)	Hose-Hyd Med04 Jf/Jf	1
13	82843	(000000-xxxxxx)	Hose-Hyd Med08 Jf/J9	1
14	82820	(000000-xxxxxx)	Hose-Hyd Med08 Jf/J9	1
15	65195	(000000-xxxxxx)	Hose-Hyd Med06 Jf/J9	1
16	65212	(000000-xxxxxx)	Hose-Hyd Low06 Jf/J9	1
17	65204	(000000-xxxxxx)	Hose-Hyd Med08 Jf/J4	1
18	34355	(000000-xxxxxx)	Hose-Hyd Med08 Jf/J9	2
19	65194	(000000-xxxxxx)	Hose-Hyd Med06 Jf/J9	2
20	34379	(000000-xxxxxx)	Hose-Hyd Med04 Jf/J9	1
21	57963	(000000-xxxxxx)	Hose-Hyd Med04 Jf/J9	1
22	65213	(000000-xxxxxx)	Hose-Hyd Low06 Jf/J9	1
23	34360	(000000-xxxxxx)	Hose-Hyd Med08 Jf/J9	2
24	33799	(000000-xxxxxx)	Hose-Hyd Med08 Jf/J4	1
25	65199	(000000-xxxxxx)	Hose-Hyd Med12 Jf/J4	1
26	01987	(000000-xxxxxx)	Hose-Hyd Med06 Jf/Jf	1
27	57485	(000000-xxxxxx)	Hose-Hyd Low12 Jf/Jf	1
28	76497	(000000-xxxxxx)	Hose-Hyd Med06 Jf/J4	1
29	65191	(000000-xxxxxx)	Hose-Hyd Med06 Jf/J4	1
30	02549	(000000-xxxxxx)	Hose-Hyd Low04 Jf/J9	2
31	76615	(000000-001050)	Hose-Hyd Replmt Kit 800/810	1
31	19618	(001051-xxxxxx)	Hose-Hyd Suc20 Jf/J4	1
32	65196	(000000-xxxxxx)	Hose-Hyd Low 04 Jf/J9	1
33	65201	(000000-xxxxxx)	Hose-Hyd Med12 Jf/J4	2
34	65205	(000000-xxxxxx)	Hose-Hyd Low12 Jf/Jf	1
35	57483	(000000-xxxxxx)	Hose-Hyd Low12 Jf/Jf	1
36	65202	(000000-xxxxxx)	Hose-Hyd Low12 Jf/Jf	1

Fig. 67 – Hydraulic Hose Group
(for machines serial number xxxxxx and above)

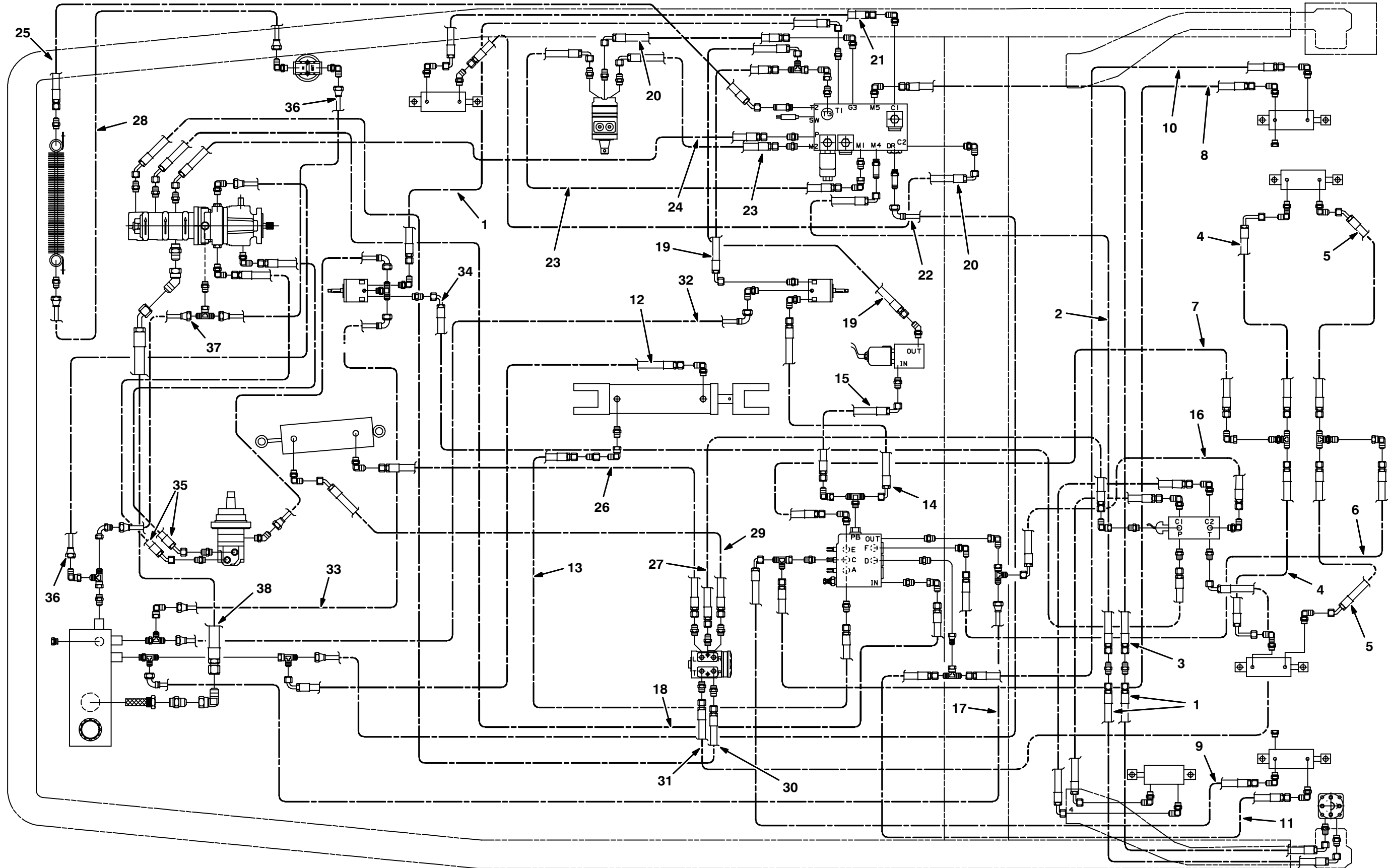

Fig. 67 – Hydraulic Hose Group
(for machines serial number xxxxxx and above)

Ref.	Tennant Part No.	Machine Serial Number	Description	Qty.
1	65194	(xxxxxx-) Hose-Hyd Med06	3
2	65197	(xxxxxx-) Hose-Hyd Med08	1
3	65224	(xxxxxx-) Hose-Hyd Med08	1
4	65188	(xxxxxx-) Hose-Hyd	2
5	57173	(xxxxxx-) Hose-Hyd Med04 Jf/J4	2
6	76498	(xxxxxx-) Hose-Hyd Ar 04	1
7	79642	(xxxxxx-) Hose-Hyd Ar04	1
8	21117	(xxxxxx-) Hose-Hyd Ar 04	1
9	21119	(xxxxxx-) Hose-Hyd Ar 04	1
10	77641	(xxxxxx-) Hose-Hyd Ar 04	1
11	77640	(xxxxxx-) Hose-Hyd Ar 04	1
12	71552	(xxxxxx-) Hose-Hyd	1
13	55700	(xxxxxx-) Hose-Hyd Med04 Jf/Jf	1
14	82843	(xxxxxx-) Hose-Hyd Med08 Jf/J9	1
15	82820	(xxxxxx-) Hose-Hyd Med78 Jf/J9	1
16	65195	(xxxxxx-) Hose-Hyd Med06	1
17	65212	(xxxxxx-) Hose-Hyd Low06	1
18	65204	(xxxxxx-) Hose-Hyd Med08	1
19	34355	(xxxxxx-) Hose-Hyd Med08 Jf/J9	2
20	57963	(xxxxxx-) Hose-Hyd Med04	4
21	34379	(xxxxxx-) Hose-Hyd Med04	1
22	65213	(xxxxxx-) Hose-Hyd Low06	1
23	34360	(xxxxxx-) Hose-Hyd Med08 Jf/J9	2
24	33799	(xxxxxx-) Hose-Hyd Med08 Jf/J4	1
25	65199	(xxxxxx-) Hose-Hyd Med12	1
26	01987	(xxxxxx-) Hose-Hyd Med06 Jf/Jf	1
27	16431	(xxxxxx-) Hose-Hyd Med06 Jf/Jf	1
28	57485	(xxxxxx-) Hose-Hyd Low12 Jf/Jf	1
29	76497	(xxxxxx-) Hose-Hyd Med06	1
30	65191	(xxxxxx-) Hose-Hyd Med06	1
31	57944	(xxxxxx-) Hose-Hyd Med06 Jf/J9	1
32	02549	(xxxxxx-) Hose-Hyd Low04 Jf/J9	2
33	65196	(xxxxxx-) Hose-Hyd Low 04	1
34	31563	(xxxxxx-) Hose-Hyd Med06 Jf/J9	1
35	65201	(xxxxxx-) Hose-Hyd Med12	2
36	65205	(xxxxxx-) Hose-Hyd Low12	2
37	65202	(xxxxxx-) Hose-Hyd Low12	1
38	77473	(xxxxxx-) Hose-Hyd Suc20 Spcl 22.5	1

Fig. 68 – Hydraulic Reservoir Group

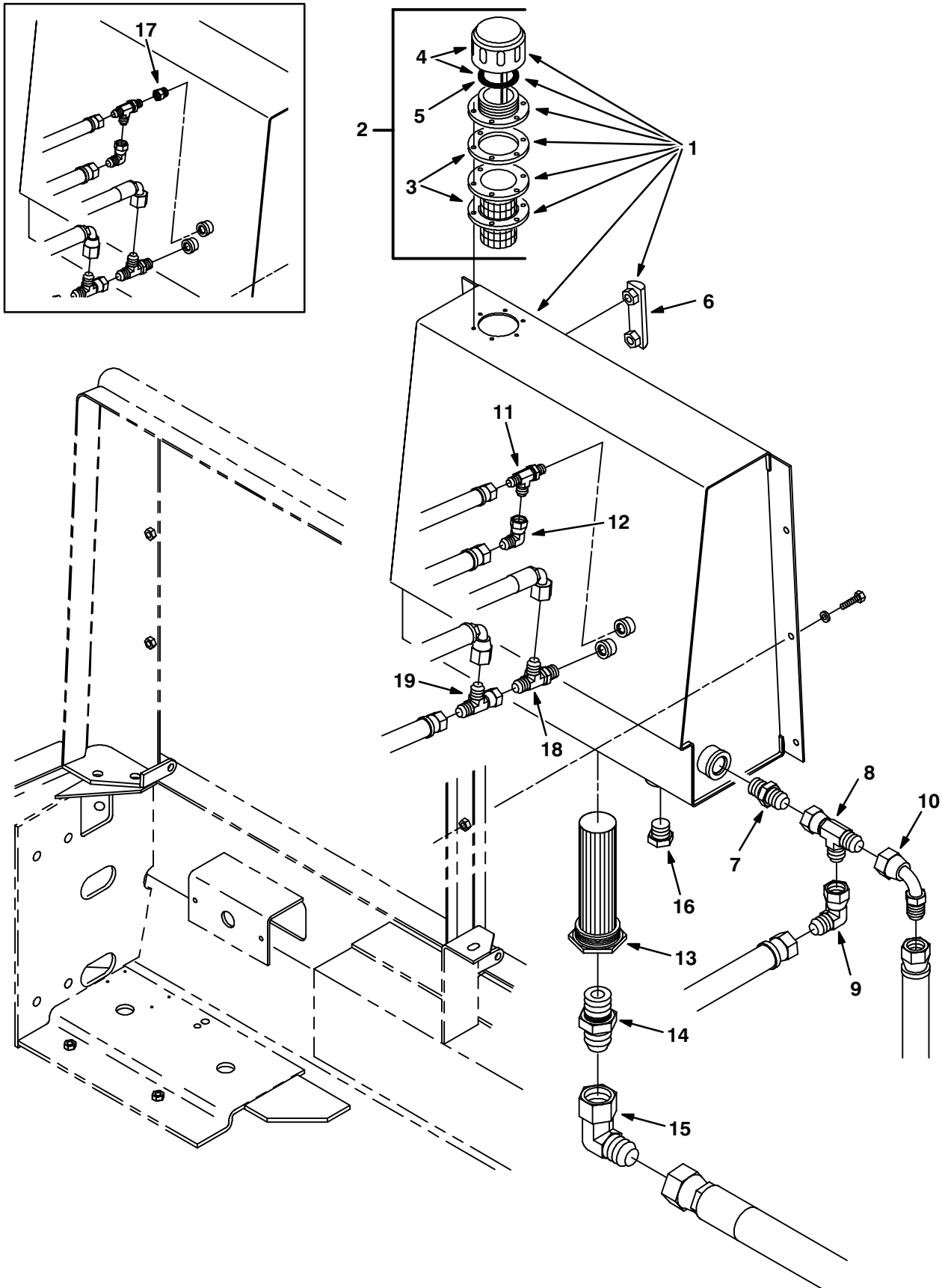

Fig. 68 – Hydraulic Reservoir Group

	Ref.	Tenant Part No.	Machine Serial Number	Description	Qty.
▽	1	63968	(000000–001150)	Tank Wldt, Hyd	1
▽	1	76906	(001151–)	Tank Wldt, Hydraulic	1
▽	2	34306	(000000–)	Breather, Hyd	1
	3	61288	(000000–)	Gasket, Hyd Tank Breather	2
	4	70072	(000000–)	Breather Cap and Gasket	1
	5	70006	(000000–)	Gasket, Hyd Cap	1
	6	65215	(000000–)	Gauge, Sight Lh	1
	7	42260	(000000–)	Ftg–Hyd Str Jm12/Om12	1
	8	40514	(000000–)	Ftg–Hyd Tee Jm12Jmjf	1
	9	35033	(000000–)	Ftg–Hyd E90 Jm12/Jf12	1
	10	57994	(000000–)	Ftg–Hyd E90 Special Jm12/Jf12	1
	11	34390	(000000–)	Ftg–Hyd Tee Jm04Jmom	1
	12	39210	(000000–)	Ftg–Hyd E90 Jm04/Jf04	1
	13	31613	(000000–)	Strainer–Hyd Suction 25–100–03	1
	14	58858	(000000–)	Ftg–Hyd Str Jm20/Om20	1
	15	19459	(000000–)	Ftg–Hyd E90	1
	16	33817	(000000–)	Ftg–Hyd Plg Om12	1
	17	87414	(000000–001150)	Ftg–Hyd Str Om/Of	1
	18	76316	(000000–)	Ftg–Hyd Tee Jm06Jmom	1
	19	42215	(000000–)	Ftg–Hyd Tee Jm06Jmjf	1

Fig. 69 – Hydraulic Solenoid Valve Group

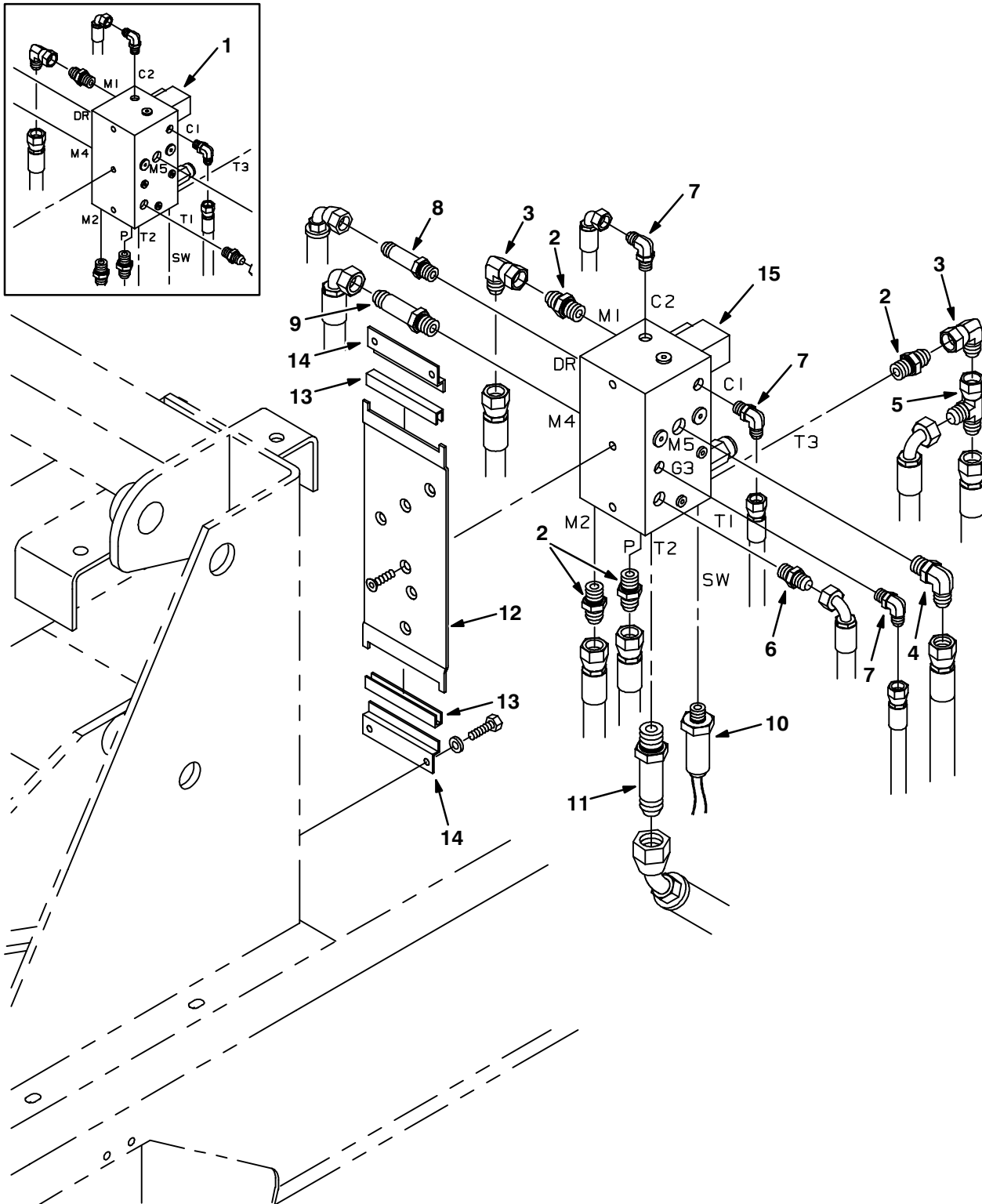

Fig. 69 – Hydraulic Solenoid Valve Group

Ref.	Tenant Part No.	Machine Serial Number	Description	Qty.
1	63527	(000000–001187)	Valve–Hyd, Solenoid (See Breakdowns)	1
2	44869	(000000–)	Ftg–Hyd Str Jm08/Om08	4
3	17980	(000000–)	Ftg–Hyd E90 Jm08/Jf08	2
4	44868	(000000–)	Ftg–Hyd E90 Jm08/Om08	1
5	45482	(000000–)	Ftg–Hyd Tee Jm08Jmjf	1
6	56690	(000000–)	Ftg–Hyd Str Jm06/Om06	1
7	77097	(000000–)	Ftg–Hyd E90 Jm04/Om04	3
8	59577	(000000–)	Ftg–Hyd Str Jm06Om06L	1
9	31605	(000000–)	Ftg–Hyd Str Jm08Om08L	1
10	70780	(000000–001146)	Switch Assy, Pressure, Hyd	1
10	77575	(001147–)	Switch Assy, Pressure, Hyd	1
11	57993	(000000–)	Ftg–Hyd Str Jm12Om12L	1
12	64228	(000000–)	Plate, Mtg, Valve, Solenoid	1
13	10911	(000000–)	Isolator, Vac Fan	2
14	06146	(000000–)	Bracket, Mounting	2
15	78996	(001188–001699)	Valve–Hyd, Solenoid (See Breakdowns)	1
15	84014	(001700–)	Valve–Hyd, Solenoid (See Breakdowns)	1

Fig. 70 – Hydraulic Lift Valve Group

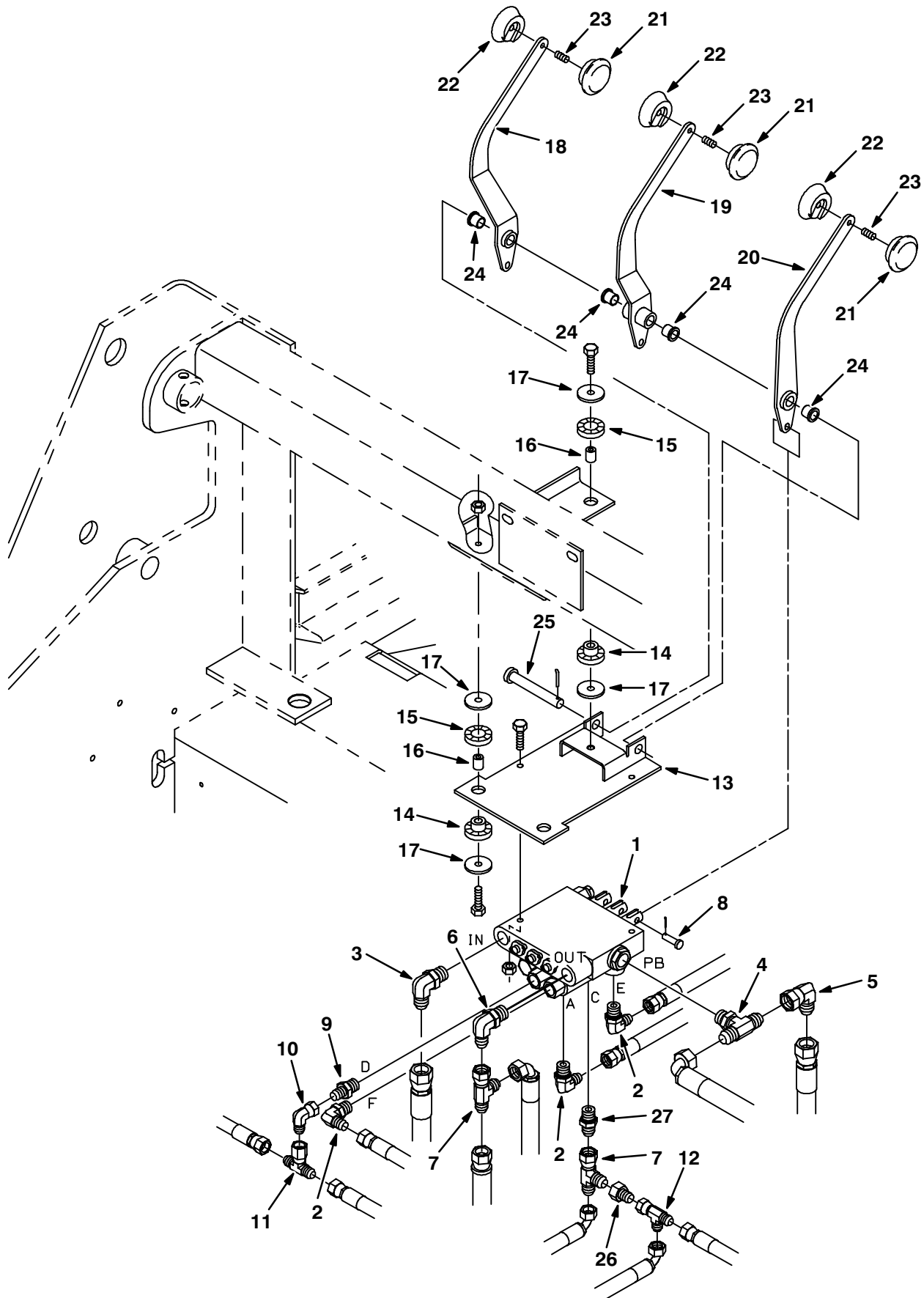

Fig. 70 – Hydraulic Lift Valve Group

Ref.	Tennant Part No.	Machine Serial Number	Description	Qty.
1	62567	(000000-001223)	Valve, Hyd, (Repl. by 77496) (See Breakdowns)	1
2	47638	(000000-001223)	Ftg-Hyd E90 Jm04/Om06	3
3	44868	(000000-001223)	Ftg-Hyd E90 Jm08/Om08	1
4	49933	(000000-001223)	Ftg-Hyd Tee Jm08OmJm	1
5	17980	(000000-001223)	Ftg-Hyd E90 Jm08/Jf08	1
6	47512	(000000-001223)	Ftg-Hyd E90 Jm06/Om08	1
7	42215	(000000-001223)	Ftg-Hyd Tee Jm06JmJf	2
8	14605	(000000-001223)	Pin,Clevis,0.25 Dia.X 0.75 Lg	3
9	55685	(000000-001223)	Ftg-Hyd Str Jm04/Om06	1
10	39210	(000000-001223)	Ftg-Hyd E90 Jm04/Jf04	1
11	57411	(000000-001223)	Ftg-Hyd Tee Jm04Jfjm	1
12	57988	(000000-001223)	Ftg-Hyd Tee Jm04Jmjf	1
13	64176	(000000-001223)	Bracket Wldt, Mtg, Valve	1
14	62173	(000000-001223)	Bushing, Isolator-Inner,Rbr.	3
15	62172	(000000-001223)	Ring	3
16	64905	(000000-001223)	Sleeve, .259B .38D .62 Dom	3
17	30013	(000000-001223)	Washer-Flt .31 Fender Pltd	6
18	64165	(000000-001223)	Handle Wldt, Rh	1
19	64166	(000000-001223)	Handle Wldt, Center	1
20	64175	(000000-001223)	Handle Wldt, Lh	1
21	64434	(000000-001223)	Knob	3
22	70827	(000000-001223)	Knob	3
23	70847	(000000-001223)	Scr Set M 6X1.0 20	3
24	36173	(000000-001223)	Bearing, Control Shaft	4
25	06474A	(000000-001223)	Pin,Clevis,0.50 Dia.X 3.50 Lg	1
26	47752	(000000-001223)	Ftg-Hyd Str Jm04/Jf06	1
27	56690	(000000-001223)	Ftg-Hyd Str Jm06/Om06	1

Fig. 71 – Hydraulic Lift Valve Group

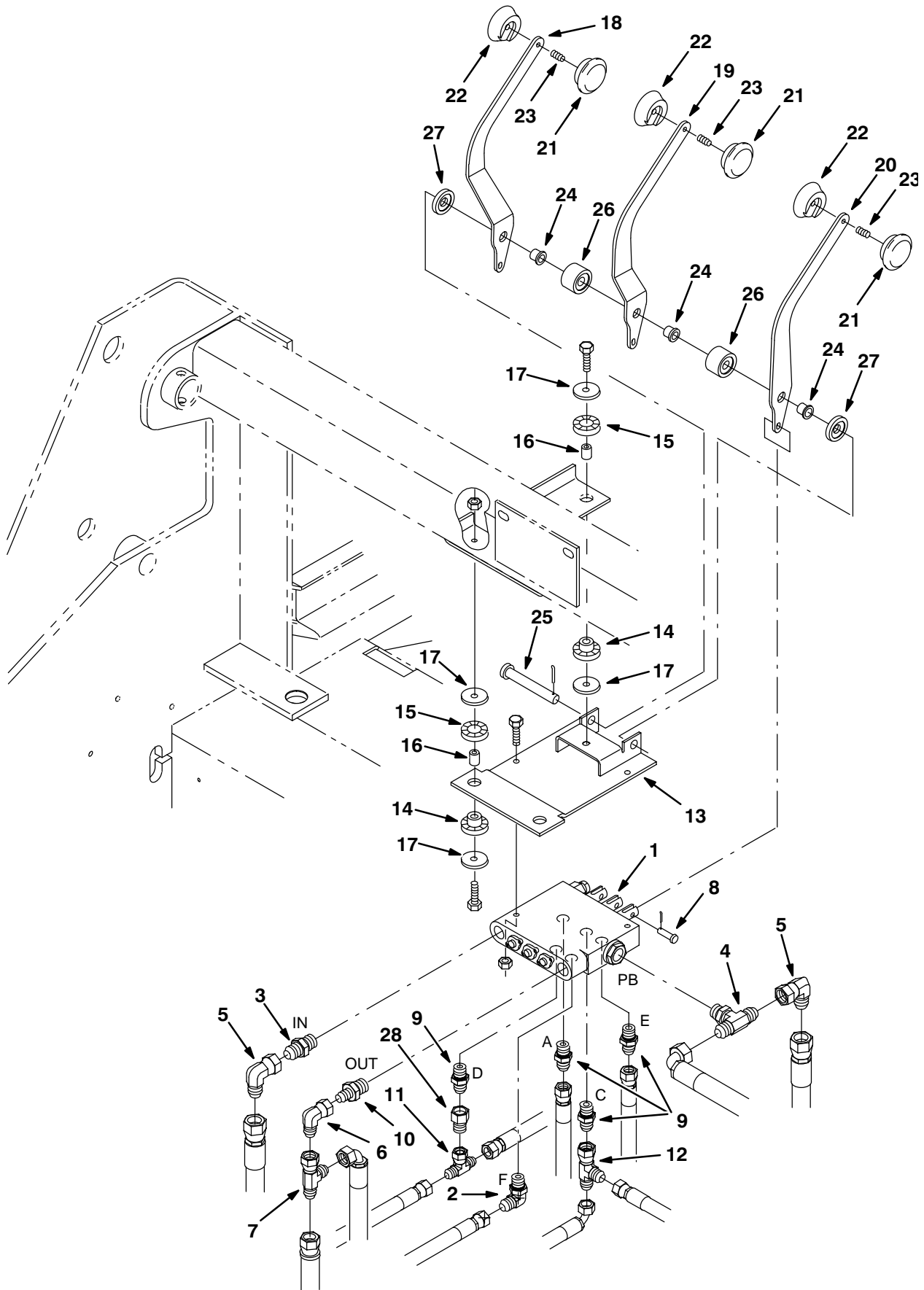

Fig. 71 – Hydraulic Lift Valve Group

Ref.	Tennant Part No.	Machine Serial Number	Description	Qty.
1	77495	(001224–) Valve, Hyd Control Man (See Breakdowns)	1
2	47638	(001224–) Ftg–Hyd E90 Jm04/Om06	1
3	44869	(001224–) Ftg–Hyd Str Jm08/Om08	1
4	49933	(001224–) Ftg–Hyd Tee Jm08Omjm	1
5	17980	(001224–) Ftg–Hyd E90 Jm08/Jf08	2
6	47504	(001224–) Ftg–Hyd E90 Jm06/Jf06	1
7	42215	(001224–) Ftg–Hyd Tee Jm06Jmjf	2
8	77488	(001224–) Pin, Clevis .18 Dia.X .62 Lg	3
9	55685	(001224–) Ftg–Hyd Str Jm04/Om06	3
10	52402	(001224–) Ftg–Hyd Str Jm06/Om08	1
11	57411	(001224–) Ftg–Hyd Tee Jm04Jfjm	1
12	57988	(001224–) Ftg–Hyd Tee Jm04Jmjf	1
13	77485	(001224–) Bracket Wldt, Mounting, Valve	1
14	62173	(001224–) Bushing, Isolator–Inner,Rbr.	3
15	62172	(001224–) Ring	3
16	64905	(001224–) Sleeve, .259B .38D .62 Dom	3
17	30013	(001224–) Washer–Flt .31 Fender Pltd	6
18	77491	(001224–) Handle, Rh	1
19	77492	(001224–) Handle, Center	1
20	77493	(001224–) Handle, Lh	1
21	64434	(001224–) Knob	3
22	70827	(001224–) Knob	3
23	70847	(001224–) Screw Set M 6X1.020	3
24	36556	(001224–) Bearing, Nylon .50B	3
25	06474A	(001224–) Pin,Clevis,0.50 Dia.X 3.50 Lg	1
26	77498	(001224–) Spacer, .90L	2
27	77499	(001224–) Spacer, .25 L	2
28	16455	(001224–) Ftg–Hyd Rst JM04/.047	1

Fig. 72 – Side Brush Group

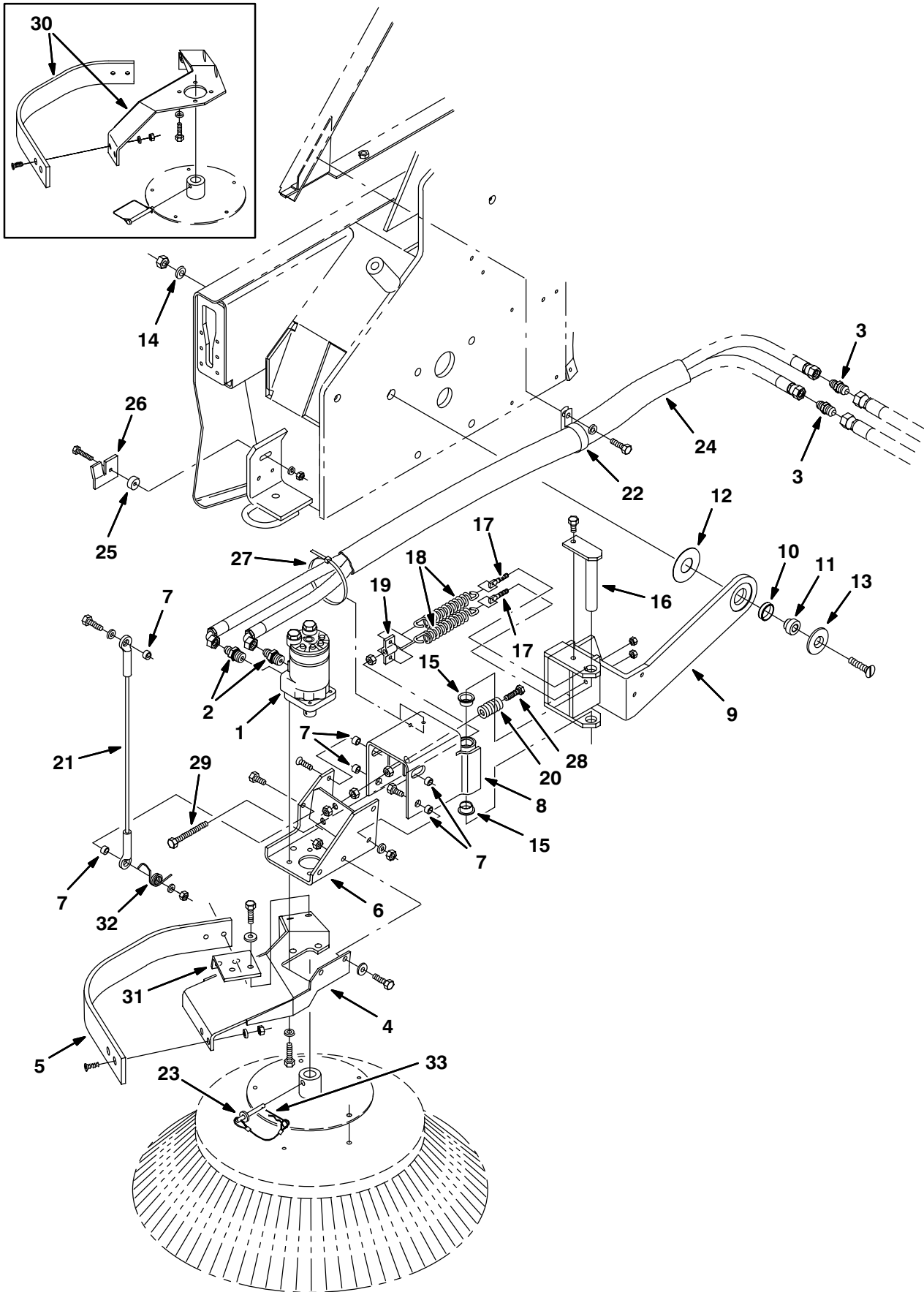

Fig. 72 – Side Brush Group

Ref.	Tennant Part No.	Machine Serial Number	Description	Qty.
1	62564	(000000–001477)	Motor, Hyd, (Repl. by 79781) (See Breakdowns)	1
1	79781	(001478–)	Motor, Hyd, (See Breakdowns)	1
2	47508	(000000–)	Ftg–Hyd Str Jm06/Om10	2
3	42207	(000000–)	Ftg–Hyd Str Jm08/Jm06	2
4	21224	(001321–)	Guard Wldt, Side Brush	1
5	21238	(001321–)	Guard, Side Brush	1
6	65168	(000000–)	Bracket, Mounting, Motor	1
7	65174	(000000–)	Spacer	6
8	65170	(000000–)	Bracket, Pivot	1
9	70521	(000000–)	Bracket, Lift	1
10	70627	(000000–)	Bearing	1
11	70526	(000000–)	Shaft, Pivot	1
12	70524	(000000–)	Washer, 1.300B 3.000	1
13	70525	(000000–)	Spacer	1
14	36328	(000000–)	Washer–Belleville .50 Pltd	1
15	04761	(000000–)	Bearing, Flange .875 Bore	2
16	70431	(000000–)	Pin	1
17	70626	(000000–)	Bolt–Eye M8–1.25	2
18	65160	(000000–)	Spring, Extension	2
19	65173	(000000–)	Bracket, Spring	1
20	65180	(000000–)	Spring, Comp	1
21	70532	(000000–)	Cable, Retaining, Side Brush	1
22	86328	(000000–)	Clamp, Cable 1.5 Dia	1
23	21035	(000000–)	Pin Assy, .312X3.0 W/Lanyard	1
24	75028	(000000–)	Sleeve, Nylon #27 65.0L	1
25	74059	(000000–)	Spacer	1
26	74060	(000000–)	Bracket, Angle	1
27	49263	(000000–)	Tie Cable 3.00D Max 11.41Lg	1
28	06537	(000000–)	Screw–Hex M10X1.5	1
29	76438	(000000–)	Screw–Hex M10X1.5 90 Full Thd	1
30	21239	(000000–001320)	Guard, Side Brush Repl Kit Rh	1
31	21215	(001321–)	Plate, Angle	1
32	79123	(000000–)	Spring, Torsion , Rh	1
33	44906	(000000–)	Pin,Hair Cotter #Lhcot–2,Leitk	1

Fig. 73 – Side Brush Lift Group

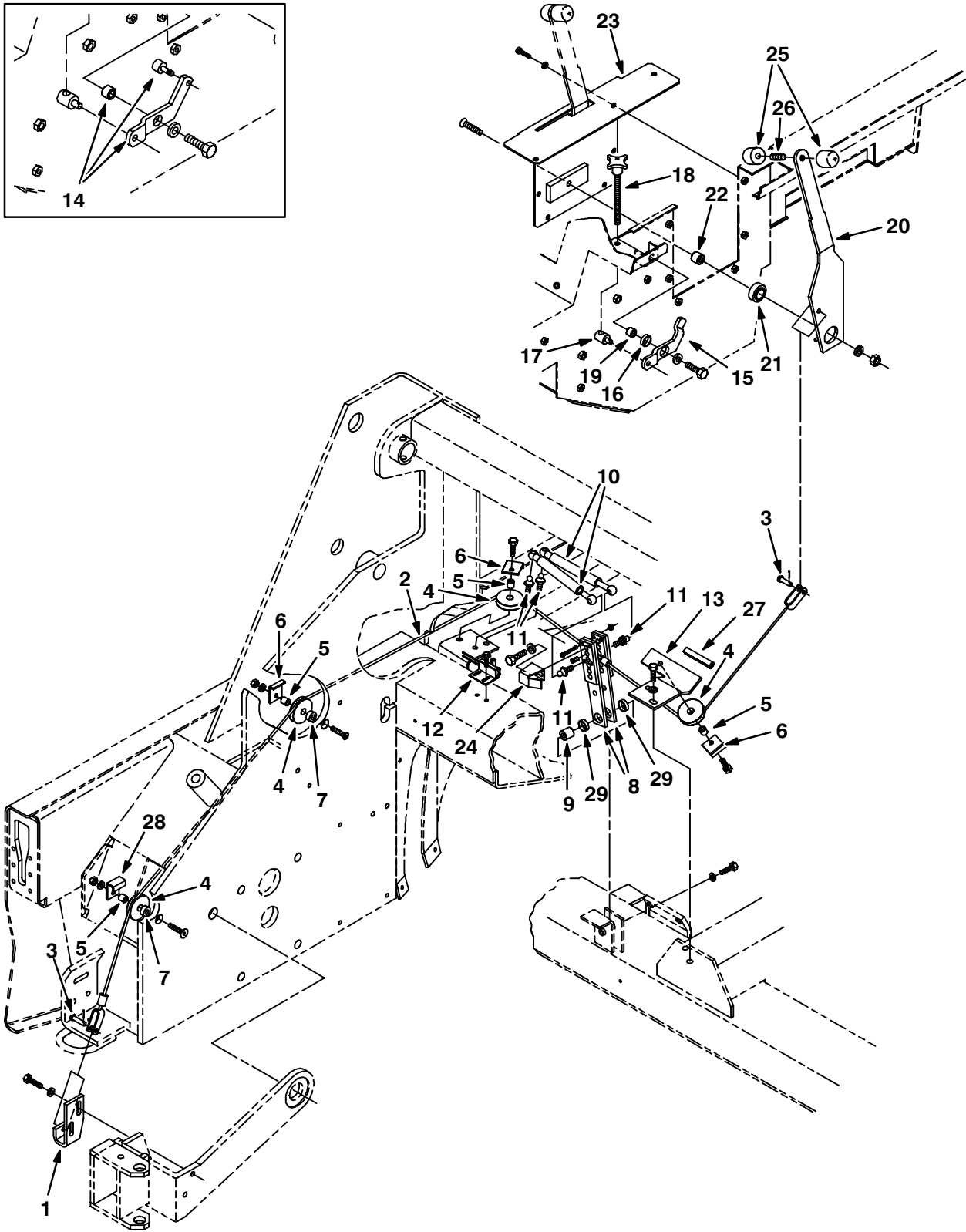

Fig. 73 – Side Brush Lift Group

Ref.	Tennant Part No.	Machine Serial Number	Description	Qty.
1	73856	(000000–001176)	Bracket, Channel	1
2	65294	(000000–001176)	Cable Assy, Side Brush, Lift	1
3	69582	(000000–001176)	Pin,Clevis,0.31 Dia X 1.00 Lg	2
4	58279	(000000–001176)	Pulley – Cable, 1.5 Dia	4
5	56624	(000000–001176)	Spacer, Pulley	4
6	54400	(000000–001176)	Angle, Cable Keeper	4
7	73737	(000000–001176)	Sleeve, .375B .75D .32 Stl	2
8	74031	(000000–001176)	Lever Wldt	2
9	73818	(000000–001176)	Sleeve, .375B .75D .75 Stl	1
10	73714	(000000–001176)	Strip, Retainer, Seal, Rh	2
11	58494	(000000–001176)	Stud, Ball, Gas Spring	4
12	59962	(000000–001176)	Switch, Roller	1
13	70715	(000000–001176)	Plate, Angle	1
14	76339	(000000–001065)	Side Brush Lever Adjustmt Kit	1
15	75893	(001066–001176)	Lever	1
16	74090	(001066–001176)	Bearing	1
17	70444	(000000–001176)	Rod, Cam Adjuster	1
18	54848	(000000–001176)	Knob, Adjusting	1
19	75894	(001066–001176)	Spacer	1
20	73860	(000000–001176)	Handle	1
21	54663	(000000–001176)	Bearing, Self Aligning	1
22	70720	(000000–001176)	Spacer	1
23	70721	(000000–001176)	Plate Wldt, Cover	1
24	76619	(000000–001176)	Bracket, Switch Contact	1
25	75857	(000000–001176)	Knob, Handle, Threaded	2
26	75859	(000000–001176)	Rod–Thread, Full M10X1.5 X1.50	1
27	74068	(000000–001176)	Molding, Trim 3/16–5/16 2.75	1
28	74899	(000000–001176)	Bracket, Cable Keeper	1
29	74090	(000000–001176)	Bearing	2

Fig. 74 – Side Brush Lift Group

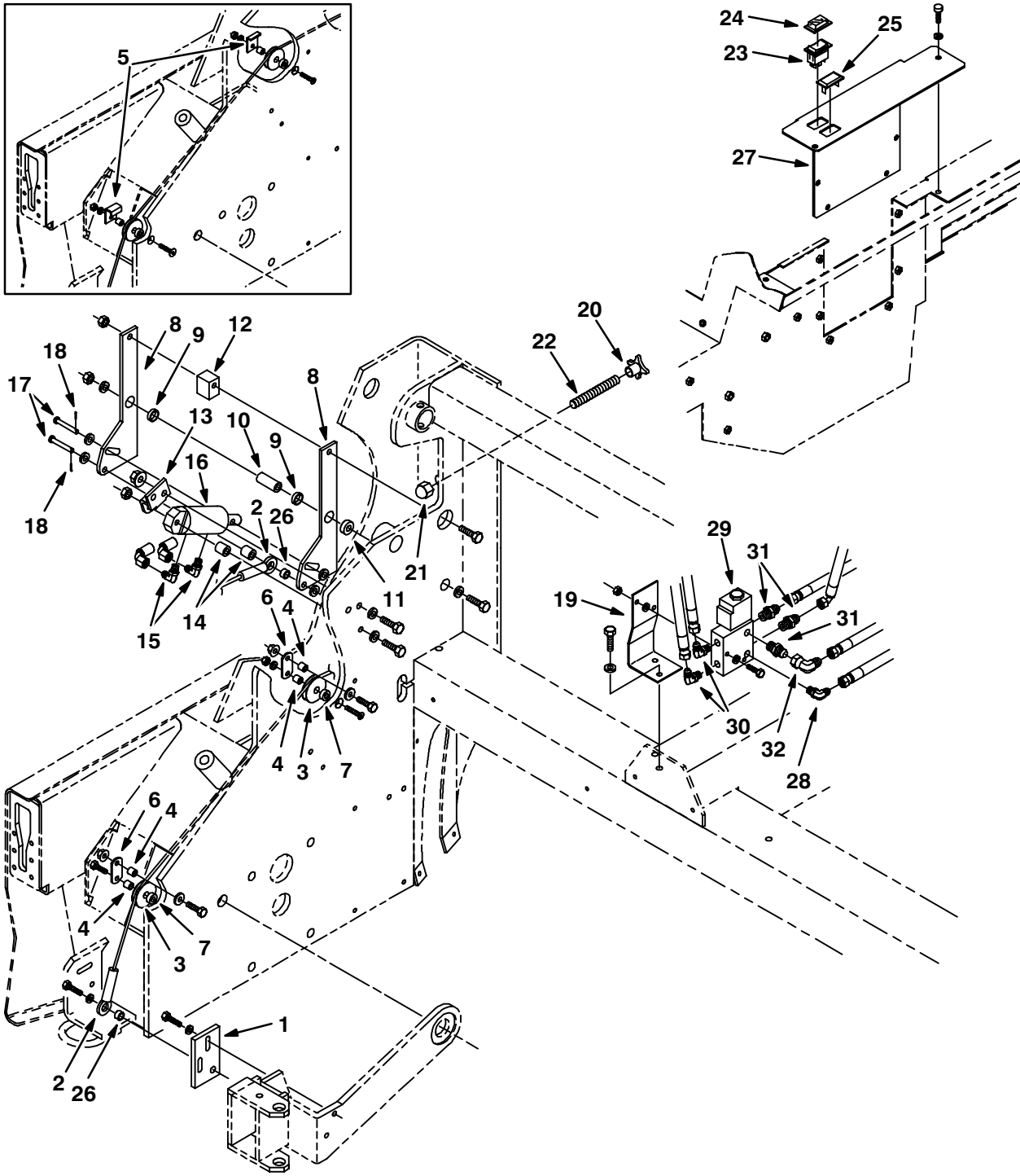

Fig. 74 – Side Brush Lift Group

Ref.	Tennant Part No.	Machine Serial Number	Description	Qty.
1	77669	(001177–)	Plate Wldt	1
2	77568	(001177–)	Cable, Side Brush, Lift	1
3	74391	(001177–)	Pulley Assy, Cable, 1.5 Dia	2
4	56624	(001177–)	Spacer, Pulley	4
5	79117	(001177–)	Retainer Replacement Kit	2
6	79115	(001177–)	Plate, Side Brush Roller	2
7	73737	(001177–)	Sleeve, .375B .75D .32 Stl	2
8	77584	(001177–)	Plate	2
9	74090	(001177–)	Bearing	2
10	77597	(001177–)	Sleeve, 0.406B 0.75D1.80 Stl	1
11	77727	(001177–)	Sleeve, .438B 1.00D .35 Stl	1
12	77459	(001177–)	Spacer	1
13	77601	(001177–)	Plate, Angle	1
14	77600	(001177–)	Sleeve,0.406B .750D .800 Stl	1
15	77097	(001177–)	Ftg–Hyd E90 Jm04/Om04	2
16	77599	(001177–)	Cylinder, Hyd 1.5B 1.5S 2500	1
17	51813	(001177–)	Pin,Clevis,0.37 Dia.X 2.12 Lg	2
18	08179	(001177–)	Pin, Cotter .094X1.00	2
19	21231	(001177–)	Plate	1
20	77605	(001177–)	Knob, Plastic	1
21	41131	(001177–)	Nut Low Crown .62–18	1
22	77682	(001177–)	Rod, Thread	1
23	65561	(001177–)	Switch Rocker Spst	1
24	57807	(001177–)	Cover, Rocker Switch Seal	1
25	57772	(001177–)	Plate–Cover	1
26	65174	(001177–)	Spacer	2
27	21109	(001177–)	Plate, Cover	1
28	56820	(001177–)	Ftg–Hyd E90	1
29	77771	(001177–001699)	Valve, Hyd Solenoid	1
29	84016	(001700–)	Valve, Hyd Solenoid (See Breakdowns)	1
30	77097	(001177–)	Ftg–Hyd E90 Jm04/Om04	2
31	56690	(001177–)	Ftg–Hyd str	3
32	47504	(001177–)	Ftg–Hyd E90	1

Fig. 75 – Main Brush Drive Group

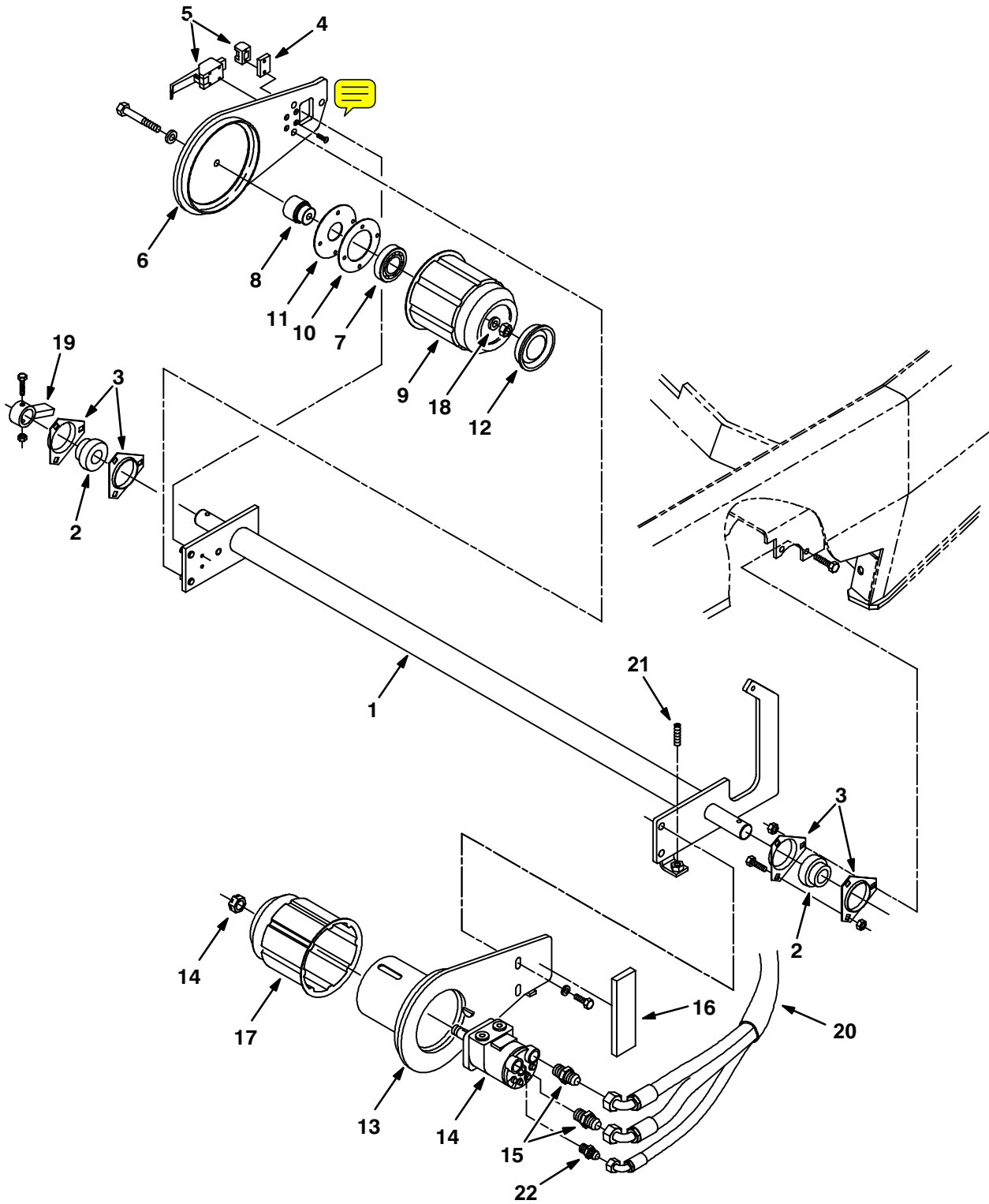

Fig. 75 – Main Brush Drive Group

Ref.	Tenant Part No.	Machine Serial Number	Description	Qty.
1	63436	(000000–) Shaft Wldt, Main Brush	1
2	51448	(000000–) Bearing&Clr ,1.25B 2.44D 1.41W	2
3	51449	(000000–) Flange,Brg,3 Hole	4
4	63541	(000000–) Plate, Mtg, Latch	1
5	54878	(000000–) Latch	1
6	63449	(000000–) Arm Wldt, M Br, Idler	1
7	24899	(000000–) Bearing–Ball,1.38B 2.83D 0.67W	1
8	30251	(000000–) Shaft, Idler	1
9	55779	(000000–) Plug Wldt, Idler	1
10	30252	(000000–) Strip, Retainer, Bearing	1
11	30253	(000000–) Plate, Seal	1
12	30255	(000000–) Plug, Tube	1
13	63450	(000000–) Arm Wldt, M Br, Motor	1
14	53434	(000000–) Motor–Hyd Gear In (See Breakdowns)	1
15	44869	(000000–) Ftg–Hyd Str Jm08/Om08	2
16	60732	(000000–) Seal Foam Rubber .75X1.5X3.5	1
17	87631	(000000–) Plug Weld, Brush Drive, Sweep	1
18	51564	(000000–) Washer, .531B 1.75D .12Cr.Znc	1
19	64811	(000000–) Bar Wldt, Brush Pressure	1
20	34330	(000000–) Sleeve, Hyd 30"	1
21	75612	(000000–) Screw, Set	1
22	55586	(000000–) Ftg–Hyd Str Jm04/Om04	1

Fig. 76 – Main Brush Lift Group

Ref.	Tennant Part No.	Machine Serial Number	Description	Qty.
1	51534	(000000–)	Pin,Clevis,0.50 Dia.X 2.00 Lg	1
2	64034	(000000–001131)	Bracket Wldt, Lift, Cylinder	1
3	54096	(000000–)	Cylinder, Hyd	1
4	77097	(000000–)	Ftg–Hyd E90 Jm04/Om04	1
5	34359	(000000–)	Ftg–Hyd E45 Jm04/Om04	1
6	33404	(000000–)	Spring, Tension	2
7	64132	(000000–)	Tube, Retainer, Spring	2
8	64233	(000000–)	Cable, Lift, Main Brush	1
9	65248	(000000–)	Bracket, Brush Lift, Main	2
10	65249	(000000–)	Tube, Spacer, Brush Lift	2
11	70583	(000000–)	Rod, Threaded .50–13	1

Fig. 77 – Main Brush Adjustment Group

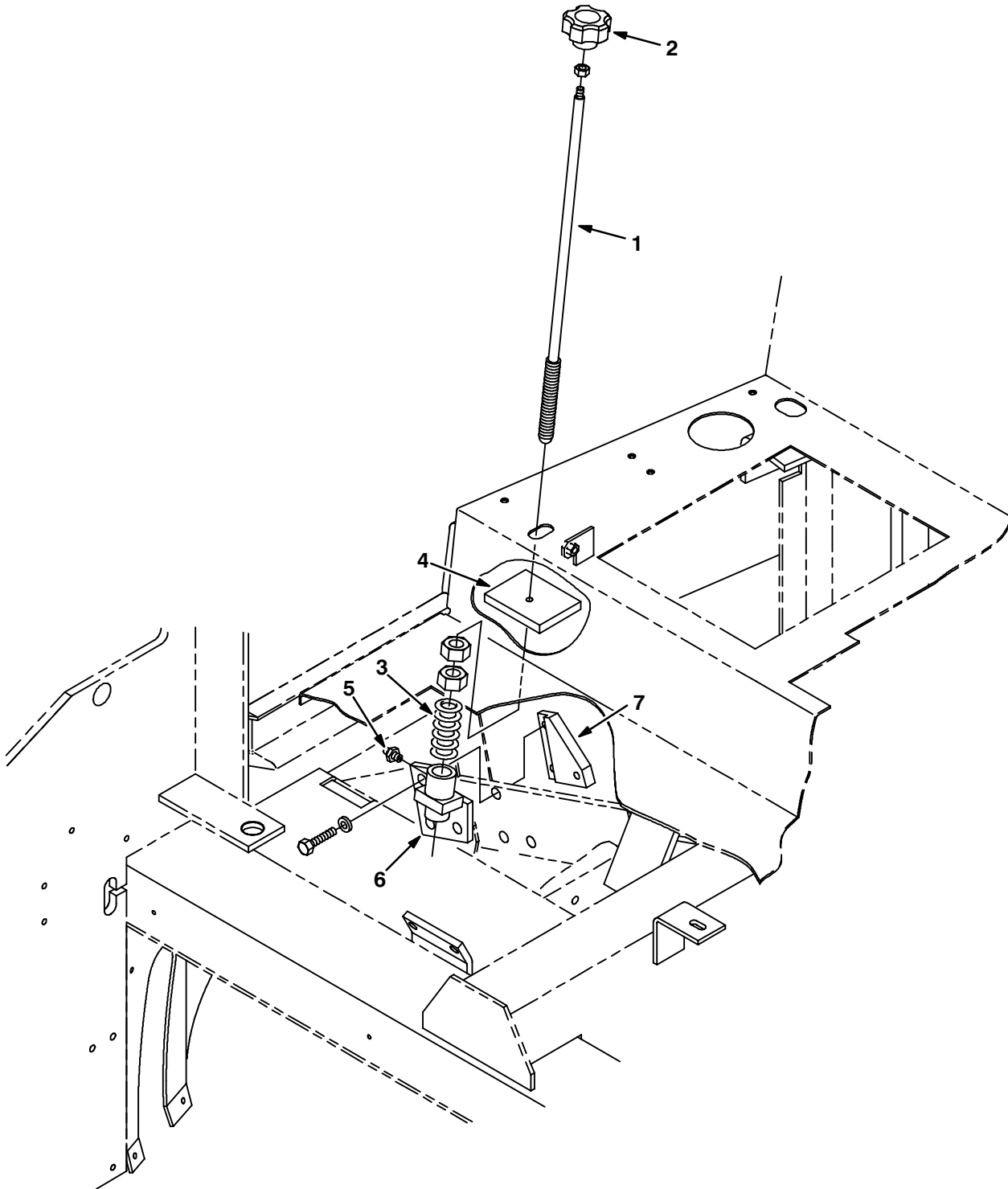

Fig. 77 – Main Brush Adjustment Group

Ref.	Tennant Part No.	Machine Serial Number	Description	Qty.
1	64812	(000000–001164)	Rod Wldt, Brush Pressure	1
2	41341	(000000–001164)	Knob, Plastic	1
3	51693	(000000–001164)	Sprng,Comp,0.87ldx.10Wire 2.5L	1
4	73762	(000000–001157)	Seal, Rod, Brush Pressure	1
5	50270	(000000–001164)	Ftg, Grease .12Nptf–Str	1
6	74005	(000000–001164)	Plate Wldt, Adj, Brush	1
7	74025	(000000–001164)	Plate, Tapped	1

Fig. 78 – Main Brush Adjustment Group

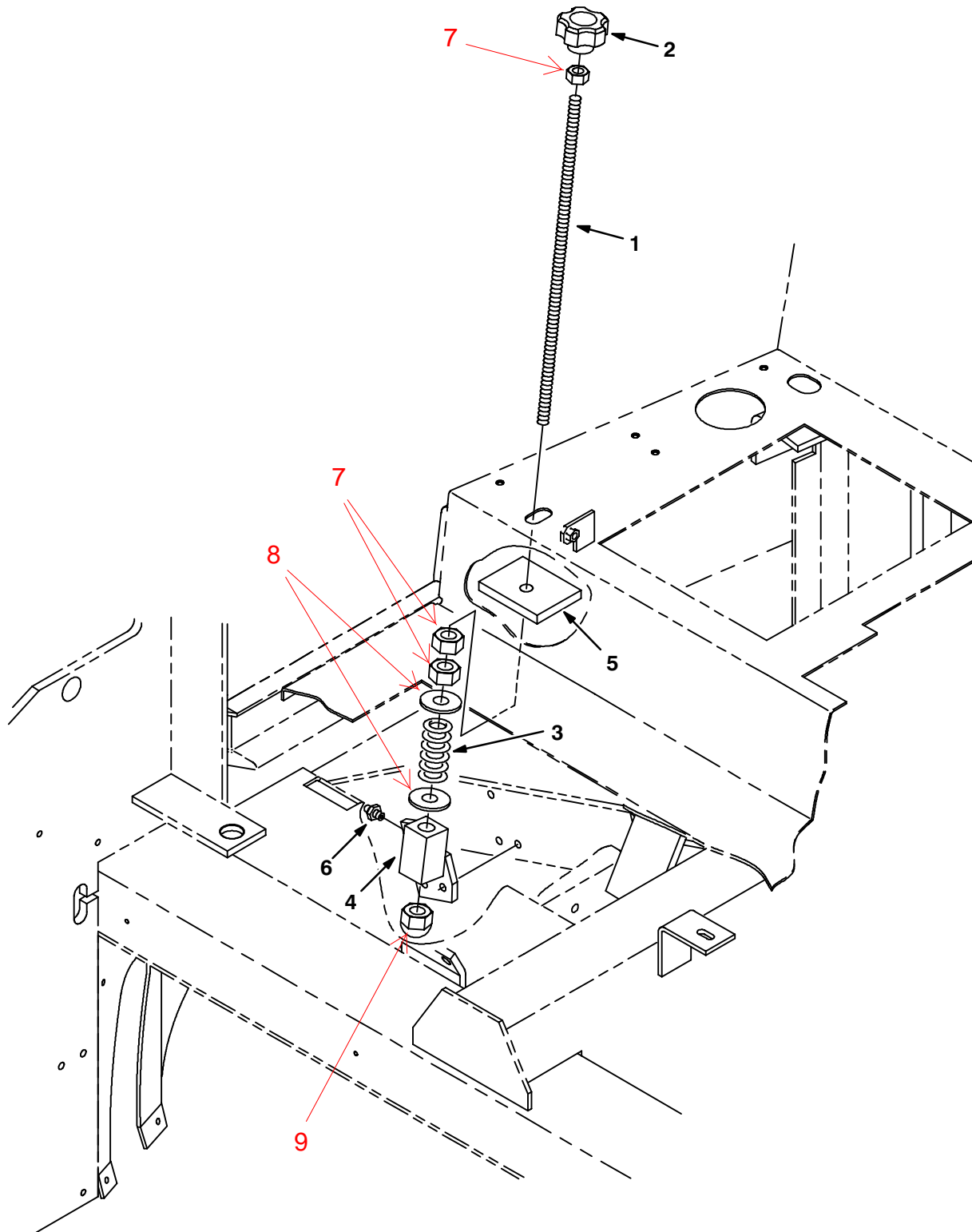

Fig. 78 – Main Brush Adjustment Group

Ref.	Tennant Part No.	Machine Serial Number	Description	Qty.
1	77578	(001165–) Rod, Thread	1
2	77605	(001165–) Knob, Plastic	1
3	51693	(001165–) Sprng,Comp,0.87ldx.10Wire 2.5L	1
4	77580	(001165–) Plate, Adj, Brush	1
5	79028	(001158–) Seal, Rod, Adjuster	1
6	11716	(001165–) Ftg, Grease.12 Npt 45 .88L	1
7	77583	(001165-) Nut, Hex Std	3
8	15331	(001165-) Washer, Flat	2
9	41131	(001165-) Nut, Low Crown	1

Fig. 79 – Vacuum Fan Impeller Group

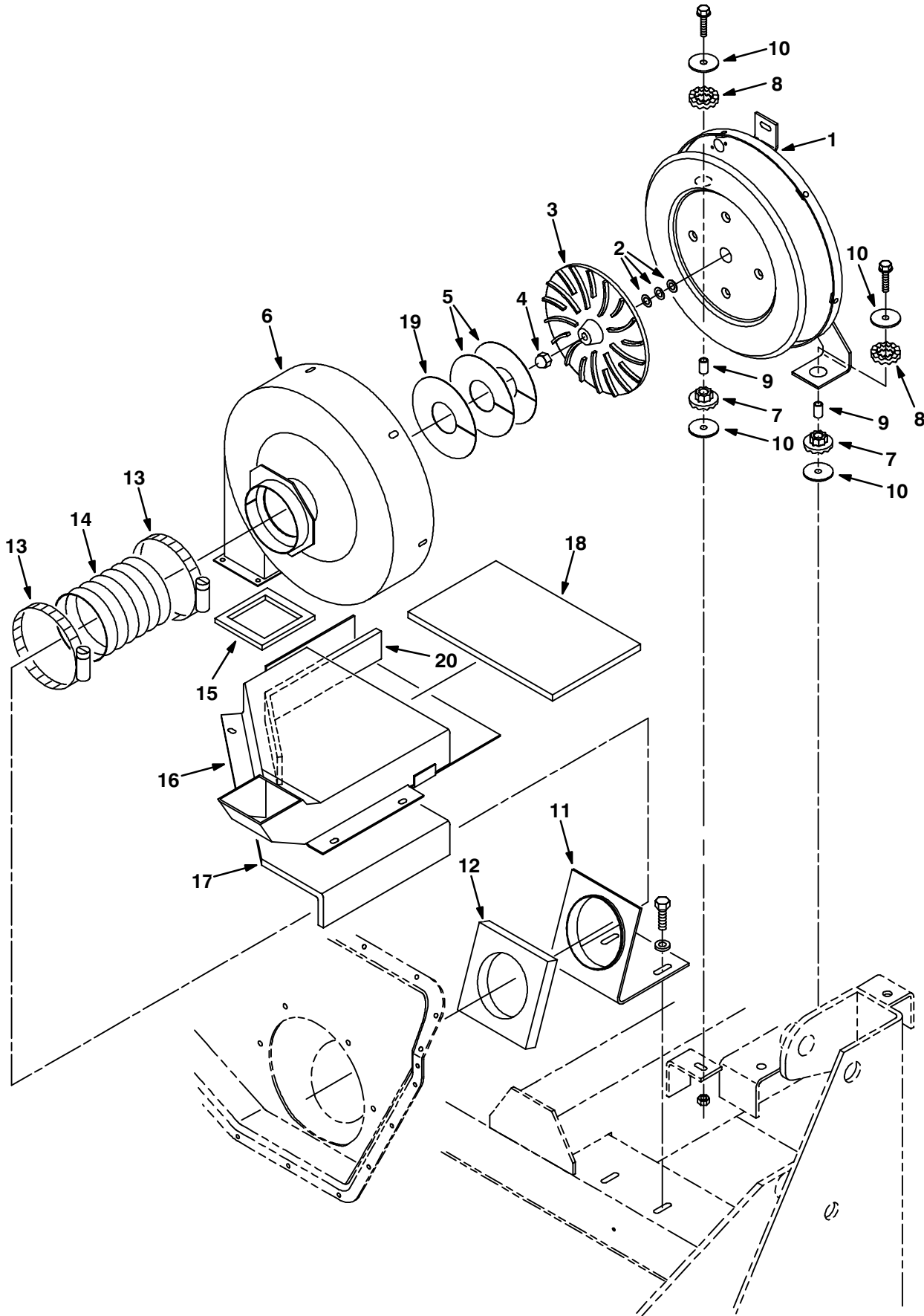

Fig. 79 – Vacuum Fan Impeller Group

Ref.	Tenant Part No.	Machine Serial Number	Description	Qty.
1	64648	(000000–001204)	Housing Wldt, Vac Fan, Rear	1
2	75456	(000000–001204)	Shim,.003Th 0.88Odx0.506ld	1
2	75456–1	(000000–001204)	Shim,.005Th 0.88Odx0.506ld	1
2	75456–2	(000000–001204)	Shim,.010Th 0.88Odx0.506ld	1
2	75456–3	(000000–001204)	Shim,.020Th 0.88Odx0.506ld	3
2	75456–4	(000000–001204)	Shim,.060Th 0.880Dxo.506ld	3
3	03922	(000000–001204)	Impeller 9.5 Dia. 18 Blade Mac	1
4	41130	(000000–001204)	Nut–Low Crown .50–20 Pltd	1
5	57543	(000000–001204)	Shim, Vac Fan Assy	2
6	70784	(000000–001204)	Housing Wldt, Vac Fan, Front	1
7	64621	(000000–001204)	Bushing, Isolator	2
8	64618	(000000–001204)	Ring, Isolator, Outer, Rbr	2
9	64299	(000000–001204)	Spacer	2
10	58228	(000000–001204)	Plate, Spring – Side Brush	4
11	70825	(000000–001204)	Bracket Wldt, Fan Inlet	1
12	74023	(000000–001204)	Gasket, Duct	1
13	73685	(000000–001204)	Clamp, Worm Drive 3.62–5.50	2
14	73646	(000000–001204)	Hose, Fan Inlet	1
15	73650	(000000–001204)	Insulation, Acoustic, Fan	1
16	70652	(000000–001204)	Panel Wldt, Duct, Vac Fan	1
17	70857	(000000–001204)	Insulation, Acoustic, Vac Fan	1
18	74009	(000000–001204)	Insulation, Acoustic, Vac Fan	1
19	31504	(000000–001204)	Shim, Vac Fan Assy	1
20	70877	(000000–001204)	Insulation, Acoustic, Vac Fan	1

Fig. 80 – Vacuum Fan Impeller Group

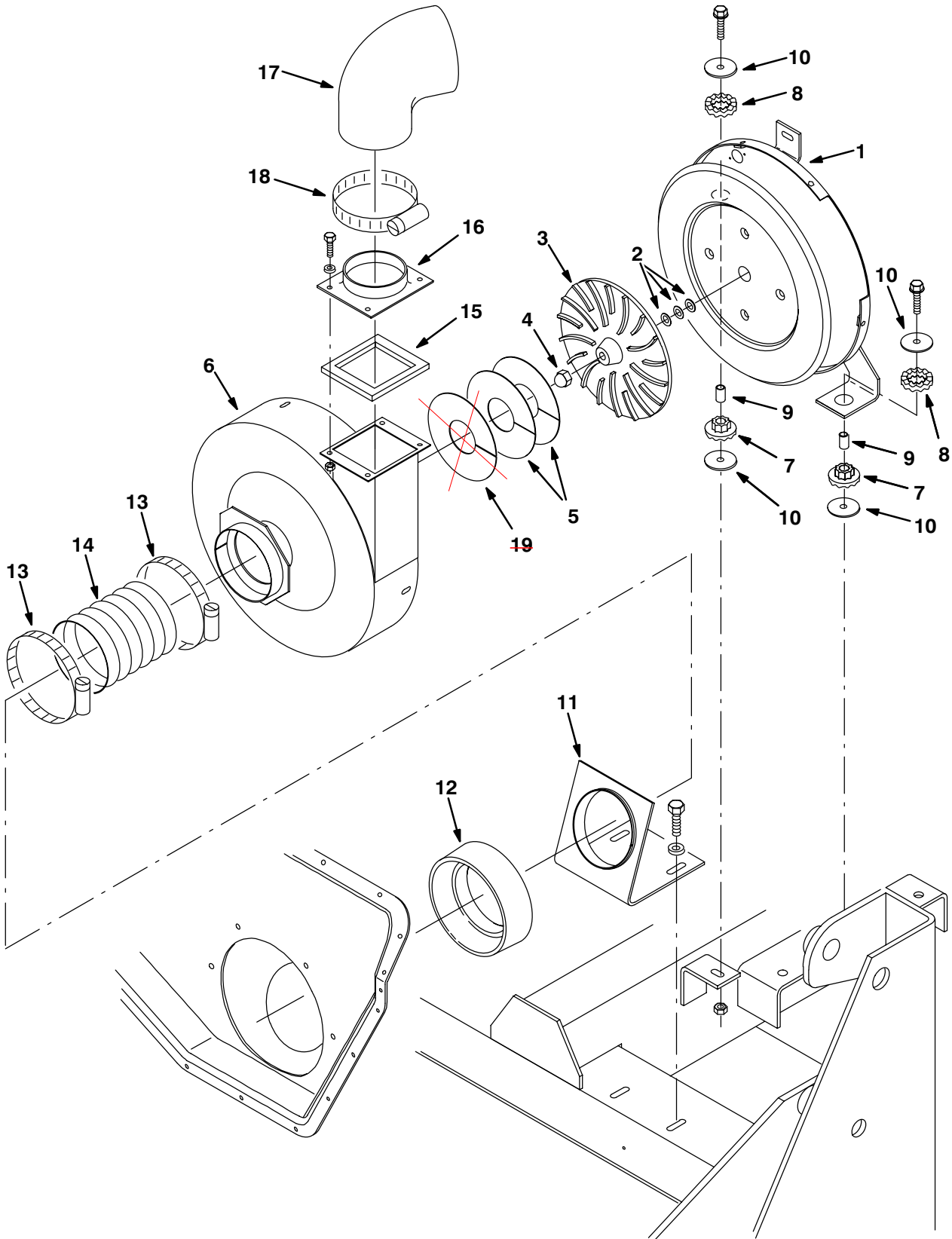

Fig. 80 – Vacuum Fan Impeller Group

Ref.	Tennant Part No.	Machine Serial Number	Description	Qty.
1	77531	(001205–)	Housing Wldt, Vac Fan, Rear	1
2	75456	(001205–)	Shim .003Th 0.88Odx0.506ld	1
2	75456–1	(001205–)	Shim .005Th 0.88Odx0.506ld	1
2	75456–2	(001205–)	Shim .010Th 0.88Odx0.506ld	1
2	75456–3	(001205–)	Shim .020Th 0.88Odx0.506ld	3
2	75456–4	(001205–)	Shim .060Th 0.880Dxo.506ld	3
3	03922	(001205–)	Impeller 9.5 Dia. 18 Blade Mac	1
4	41130	(001205–)	Nut–Low Crown .50–20 Pltd	1
5	58114	(001205–)	Fan, Repair Kit, Reassembly	1
6	77532	(001205–)	Housing Wldt, Vac Fan, Front	1
7	64621	(001205–)	Bushing, Isolator	2
8	64618	(001205–)	Ring, Isolator, Outer Rbr	2
9	64299	(001205–)	Spacer	2
10	58228	(001205–)	Plate, Spring – Side Brush	4
11	70825	(001205–)	Bracket Wldt, Fan Inlet	1
12	79122	(001205–)	Gasket, Vac Fan	1
13	73685	(001205–)	Clamp–Wormdrive, 3.62– 5.50D	2
14	73646	(001205–)	Hose, Fan Inlet	1
15	73650	(001205–)	Insulation, Acoustic, Fan	1
16	77553	(001205–)	Plate, Vac Fan	1
17	77591	(001205–)	Elbow, 90, Rubber	1
18	23498	(001205–)	Clamp–Wormdrive, 2.63– 4.50D	1
19	31504	(001205–)	Shim Vac Fanassy	4

Fig. 81 – Vacuum Fan Motor Group

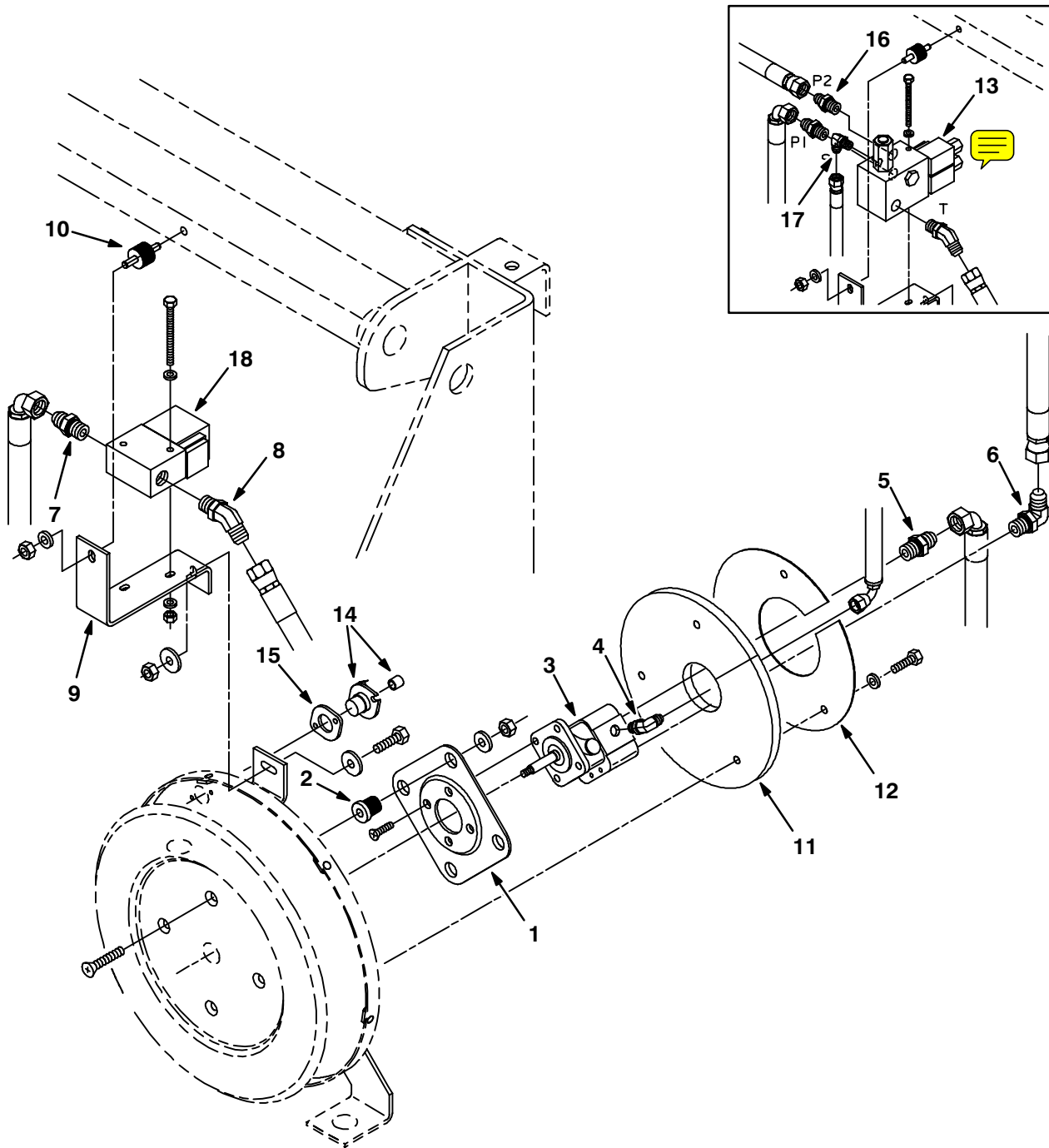

Fig. 81 – Vacuum Fan Motor Group

Ref.	Tenant Part No.	Machine Serial Number	Description	Qty.
1	54275A	(000000–)	Bracket, Mounting Motor	1
2	54274	(000000–)	Isolator–Vibration,60 Lb.Ratng	4
3	19117	(000000–)	Motor–Hyd Gear Ex (See Breakdowns)	1
4	77097	(000000–)	Ftg–Hyd E90 Jm04/Om04	1
5	56692	(000000–)	Ftg–Hyd Str Jm08/Om10	1
6	56821	(000000–)	Ftg–Hyd E90 Jm08/Om10	1
7	44869	(000000–)	Ftg–Hyd Str Jm08/Jm08	1
8	42226	(000000–)	Ftg–Hyd E45 Jm08/Om08	1
9	70775	(000000–)	Bracket, Mtg, Valve	1
10	05611	(000000–)	Isolator, Vibration	1
11	70810	(000000–)	Insulation, Acoustic, Vac Fan	1
12	70790	(000000–)	Plate, Retainer, Foam	1
13	65239	(000000–001102)	Valve–Hyd, Solenoid	1
14	02713	(000000–)	Thermostat Assembly, 155 Deg	1
15	82733	(000000–)	Gasket, Fire Switch	1
16	52402	(000000–001102)	Ftg–Hyd Str Jm08/Jm06	1
17	77097	(000000–001102)	Ftg–Hyd E90 Jm04/Om04	1
18	65391	(001103–001699)	Valve–Hyd, Solenoid (See Breakdowns)	1
18	84015	(001700–)	Valve–Hyd, Solenoid (See Breakdowns)	1

Fig. 82 – Steering Group

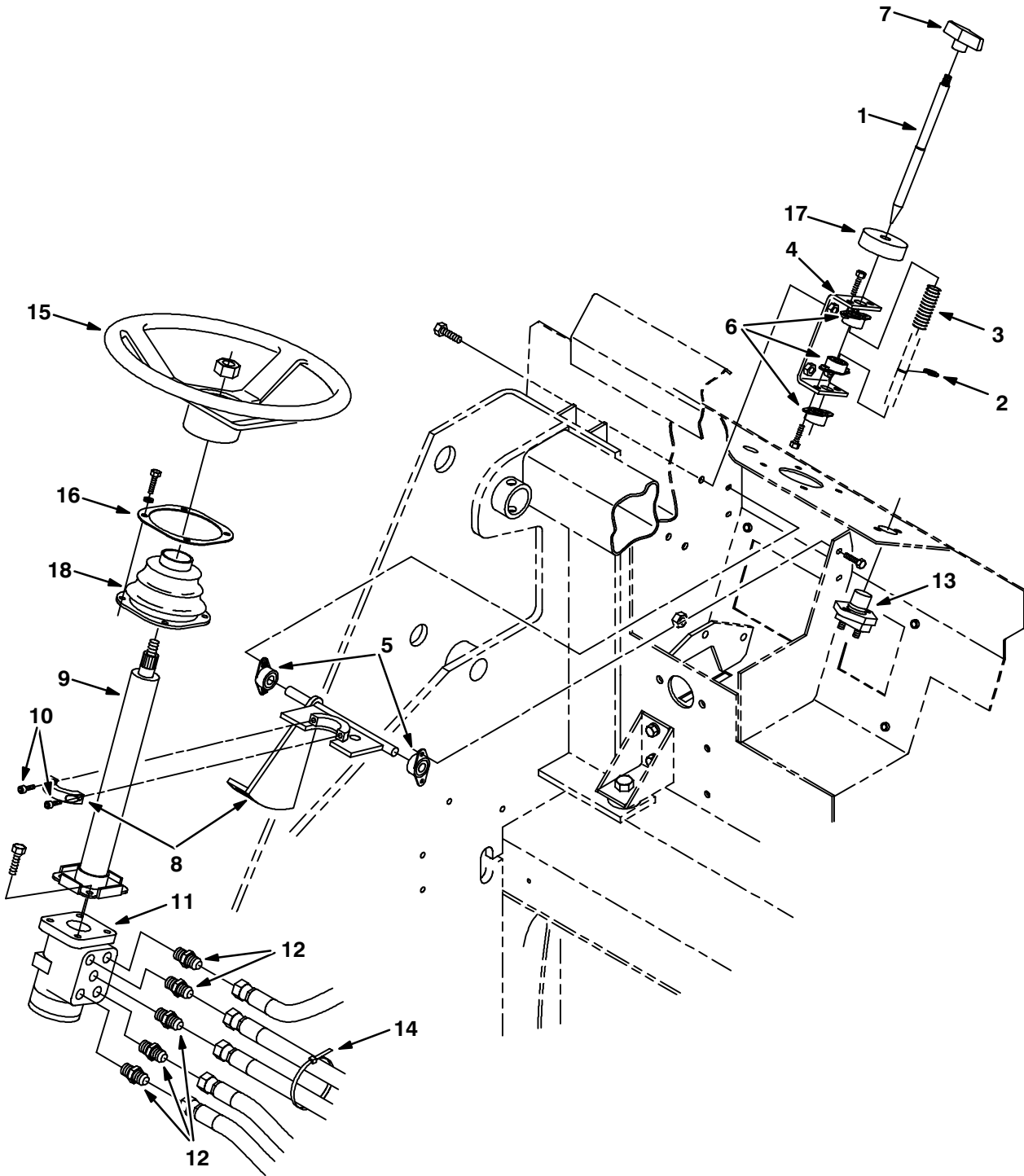

Fig. 82 – Steering Group

Ref.	Tenant Part No.	Machine Serial Number	Description	Qty.
1	64651	(000000–) Rod, Latch, Steering, Tilt	1
2	70717	(000000–) Ring,Retain,Ex,0.50Od,Heavy Dt	1
3	22290	(000000–) Sprng,Comp,0.62Idx.06Wire 2.3L	1
4	64655	(000000–) Channel, Mtg, Steering Latch	1
5	70709	(000000–) Bearing, Flange .500B	2
6	47585	(000000–) Bearing–Flange,2 Hole 0.50Bore	3
7	04706	(000000–) Handle, Lift, Brush	1
8	64586	(000000–) Bracket Wldt, Steering Tilt	1
9	64631	(000000–) Column, Steering 12"	1
10	10829	(000000–) Scr Soc .38–16X0.75	2
11	62565	(000000–001148) Steer Control, Hyd	1
11	65242	(001149–) Steer Control, Hyd	1
12	56690	(000000–) Ftg–Hyd Str Jm06/Om06	5
13	44078	(000000–) Switch, Pushmom, Spst100A 12V	1
14	49263	(000000–) Tie, Cable 3.00D Max 11.41Lg	3
15	56398	(000000–) Wheel, Steering	1
16	70623	(000000–) Plate, Mtg, Steering Boot	1
17	75968	(000000–) Seal, Bearing	1
18	70622	(000000–) Seal, Boot, Steering Column	1

Fig. 83 – Instrument Panel Assembly

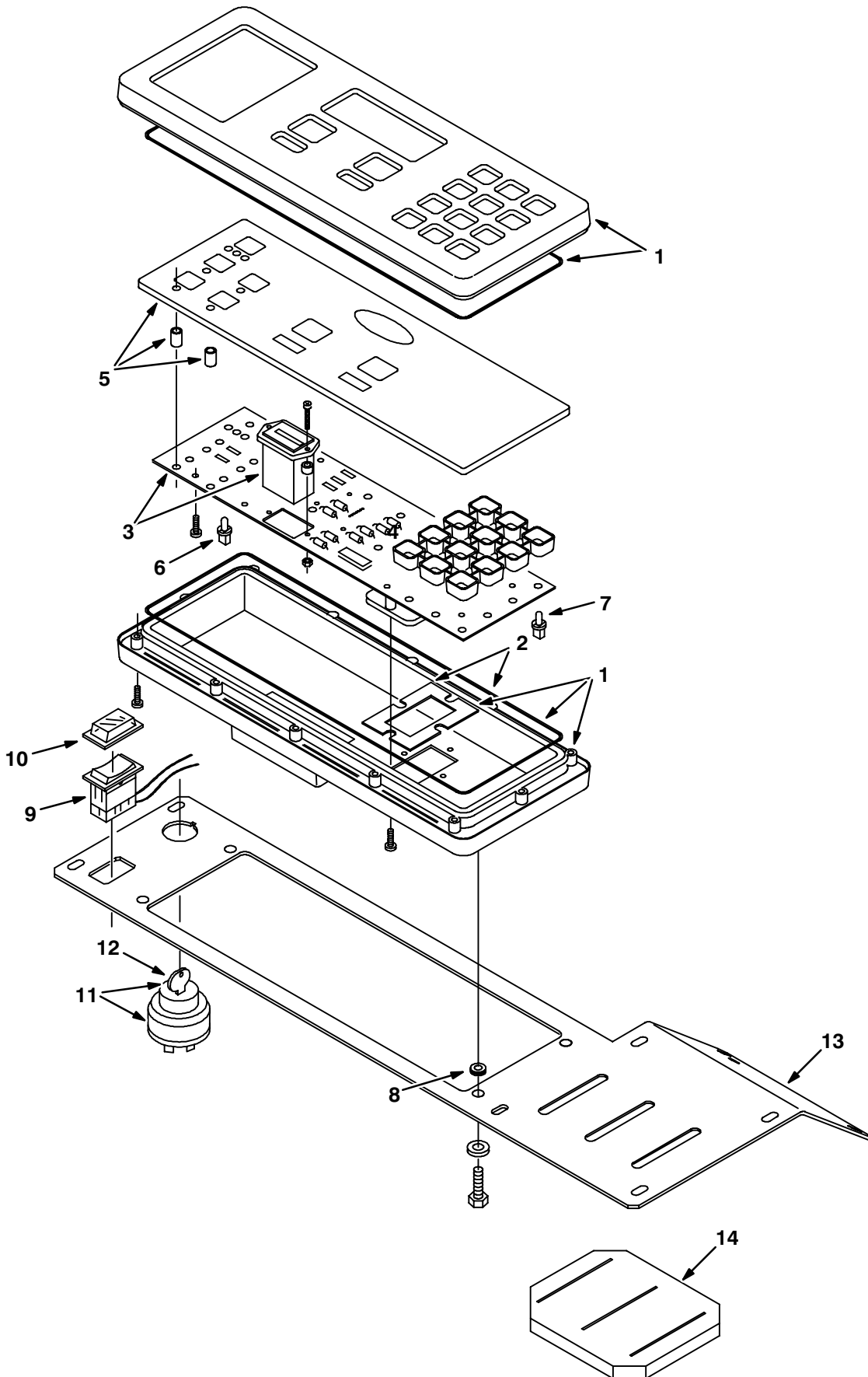

Fig. 83 – Instrument Panel Assembly

Ref.	Tenant Part No.	Machine Serial Number	Description	Qty.
∇	59970	(000000–) Replm Kit, Instr Panel	1
1	59976	(000000–) Replm Kit, Case	1
2	59977	(000000–) Replm Kit, Seal	1
∇	3	59974	(000000–) Replm Kit, Cir Board	1
4	59978	(000000–) Replm Kit, Hourmeter	1
5	59979	(000000–) Replm Kit, Touch Panel	1
6	59971	(000000–) Replm Kit, Lamp, Backlighting (Set of 8)	2
7	56346	(000000–) Replm Kit, Lamp, Fault (Set of 8)	1
8	10632–5	(000000–) Grommet,Rbr,0.25ld,For .09Matl	4
9	61969	(000000–) Switch, Rocker, Dpdt	1
10	57807	(000000–) Cover, Rocker Switch Seal	1
∇	11	87536	(000000–) Switch Ignition	1
12	87866	(000000–) Key Set,Switch Ku	1
13	65245	(000000–) Panel, Cover, Dash	1
14	79648	(000000–) Seal, Handle, Valve	1

Fig. 84 – Circuit Breaker and Relay Group

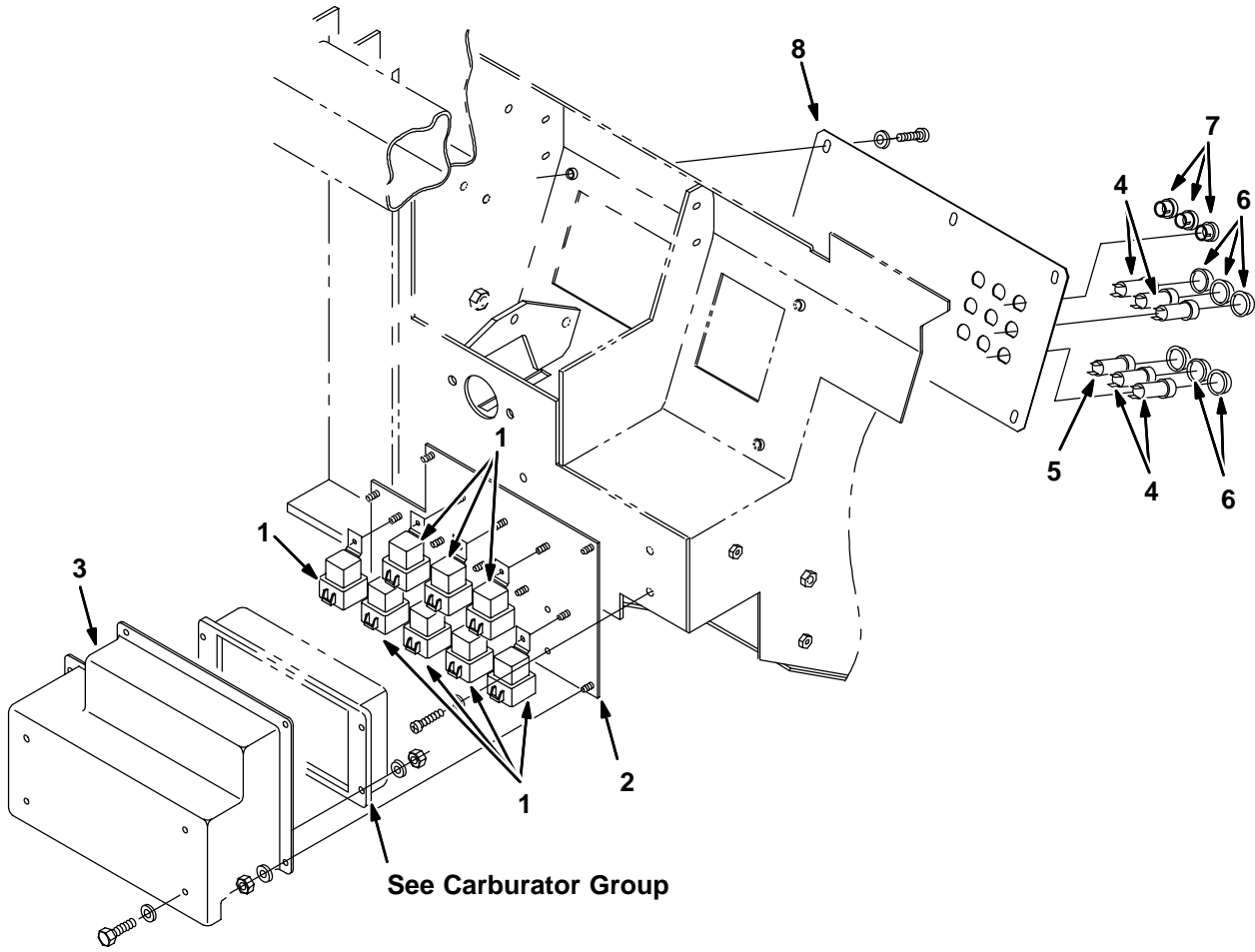

Fig. 84 – Circuit Breaker and Relay Group

Ref.	Tenant Part No.	Machine Serial Number	Description	Qty.
1	56186	(000000–) Relay, Shrouded, 12 Vdc	8
2	70398	(000000–) Plate, Mtg, Relay	1
3	70402	(000000–) Cover, Relay Panel	1
4	57803	(000000–) Breaker–Circuit, 15 Resetbl	5
5	87583	(000000–) Breaker–Circuit, 2.5 Resetbl	1
6	57751	(000000–) Boot–Circuit Breaker	6
7	57167	(000000–) Plugbtn .62H .03–.12 Blacknyl	3
8	70411	(000000–) Plate, Circuit Breaker	1

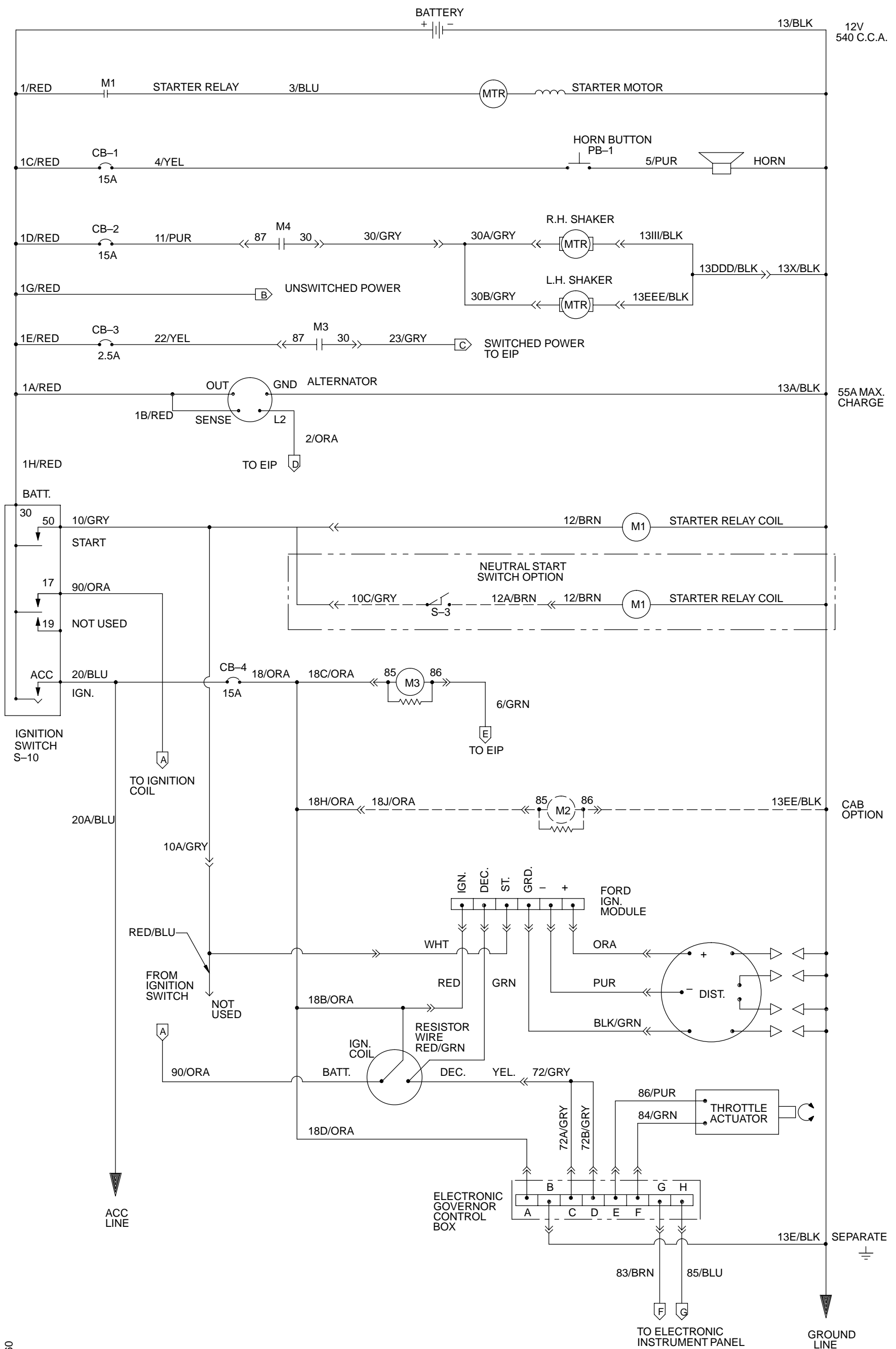

Fig. 85 - Electrical Schematic
(For machines below serial number 1700)

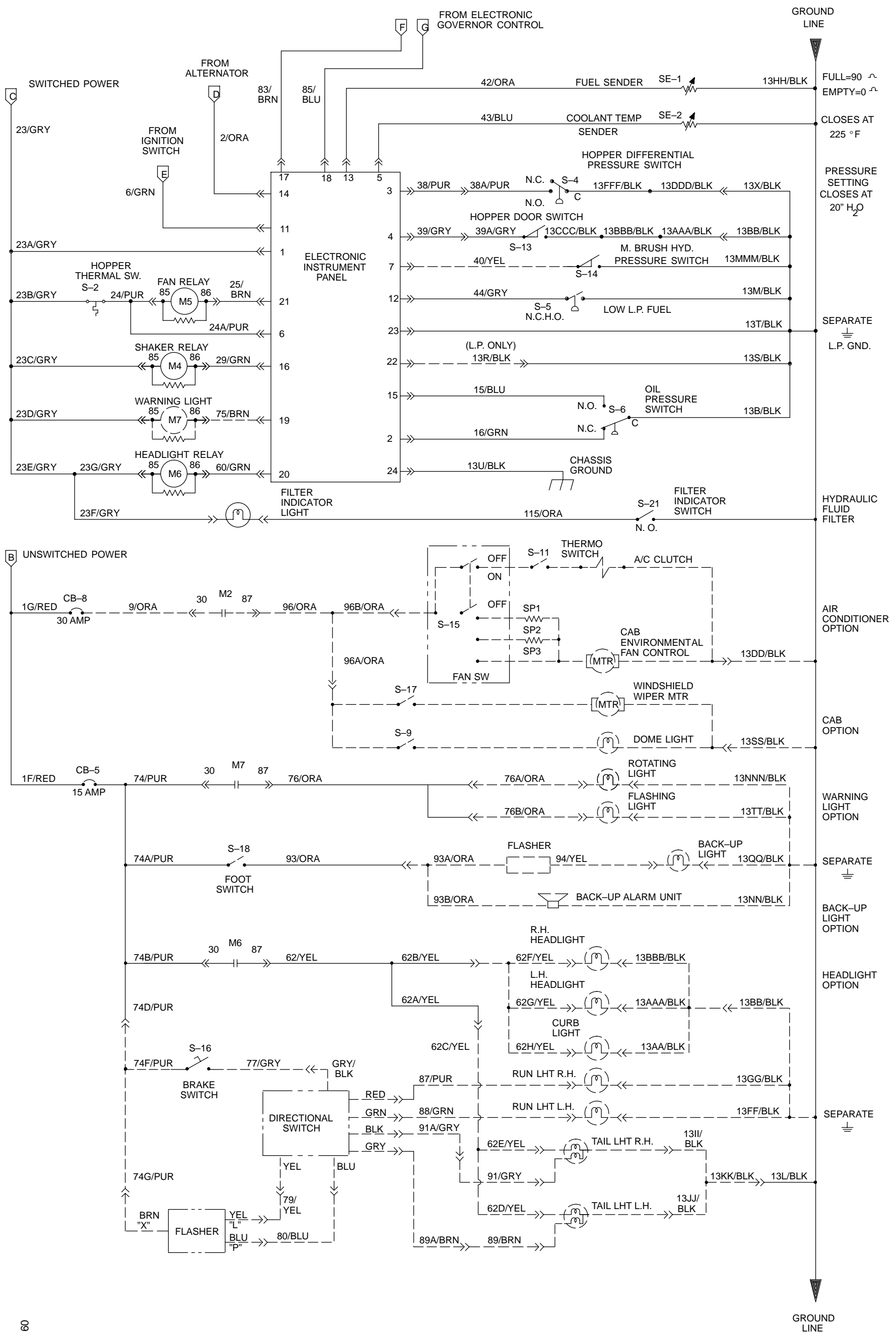
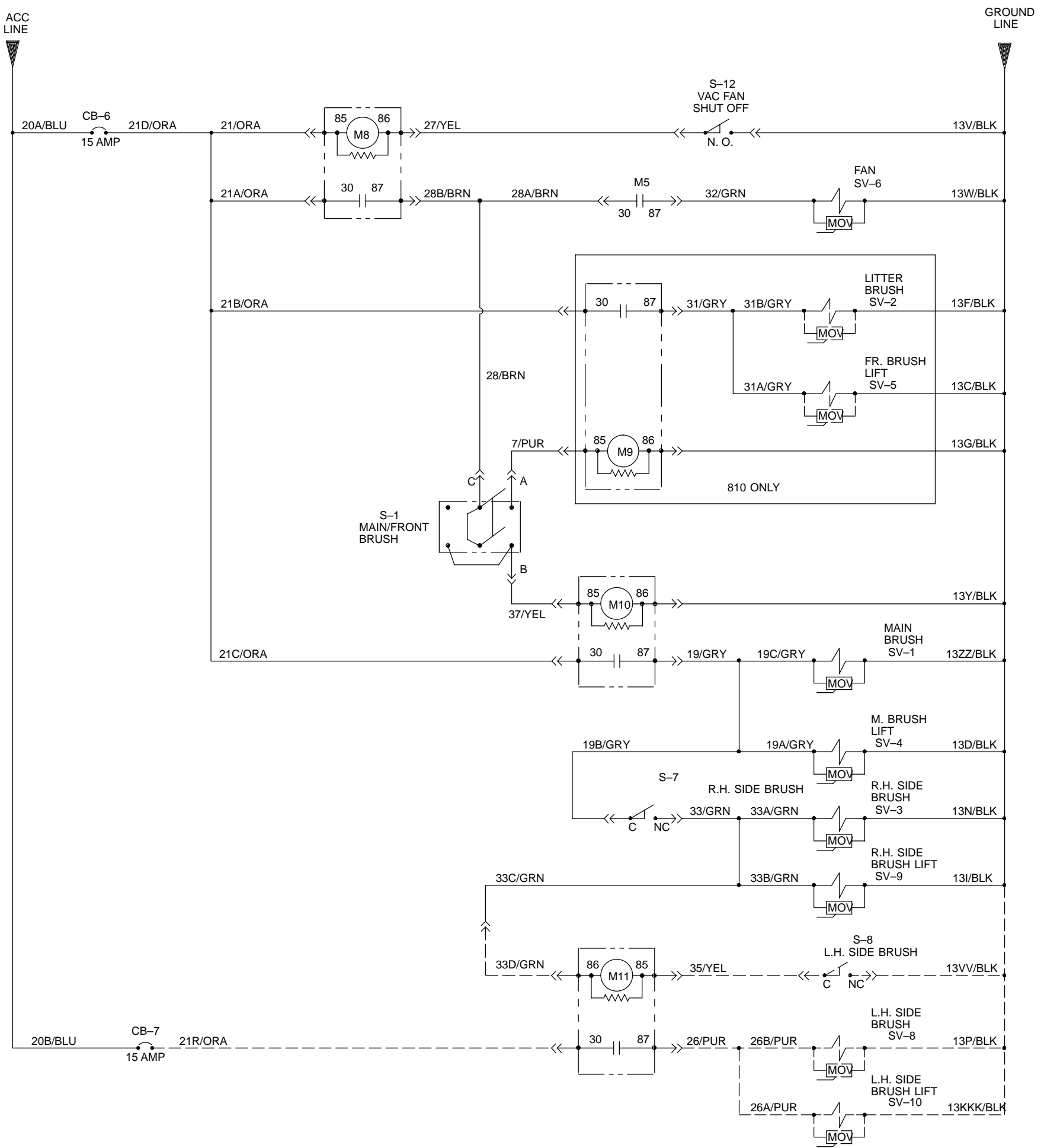

Fig. 85 - Electrical Schematic
(For machines below serial number 1700)

STANDARD PARTS



Fi 85 Electrical Schematic
For machines below serial number 1700

LEGEND			
M	POWER RELAY	HM	HOURLMETER
MTR	MOTOR	SV	SOLENOID VALVE
CB	CIRCUIT BREAKER	S	SWITCH
PM	PERMANENT MAGNET	ACC	ACCESSORY
J	JACK-FEM. SOCKET	GND	GROUND CHASSIS
P	PLUG-MALE PIN	C	COMMON
PB	PUSHBUTTON	N.O.	NORMALLY OPEN
VM	VOLTMETER	N.C.	NORMALLY CLOSED
FU	FUSE	NOV	METAL OXIDE VARISTOR

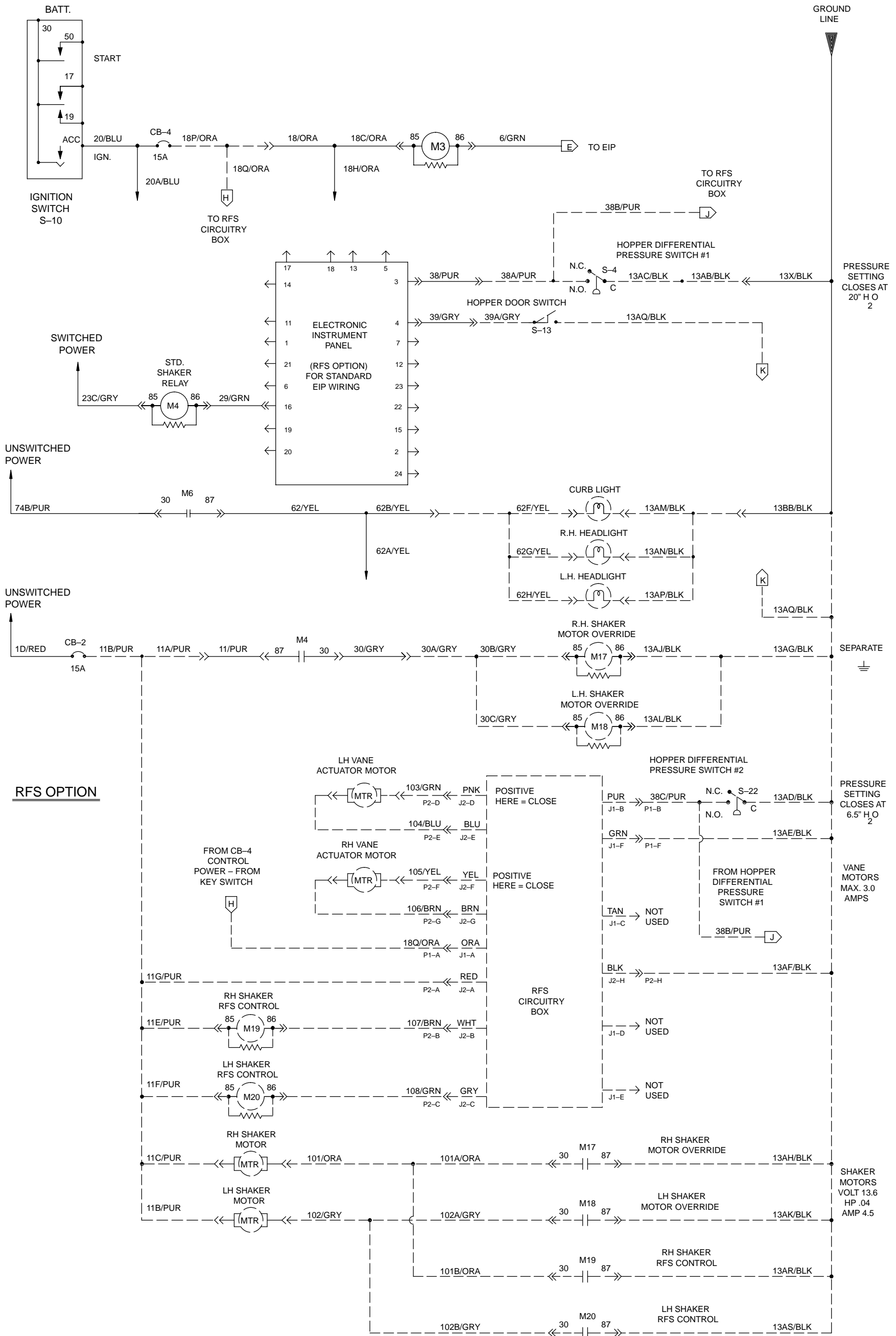

Fi 85 Electrical Schematic For machines below serial number 1700

STANDARD PARTS

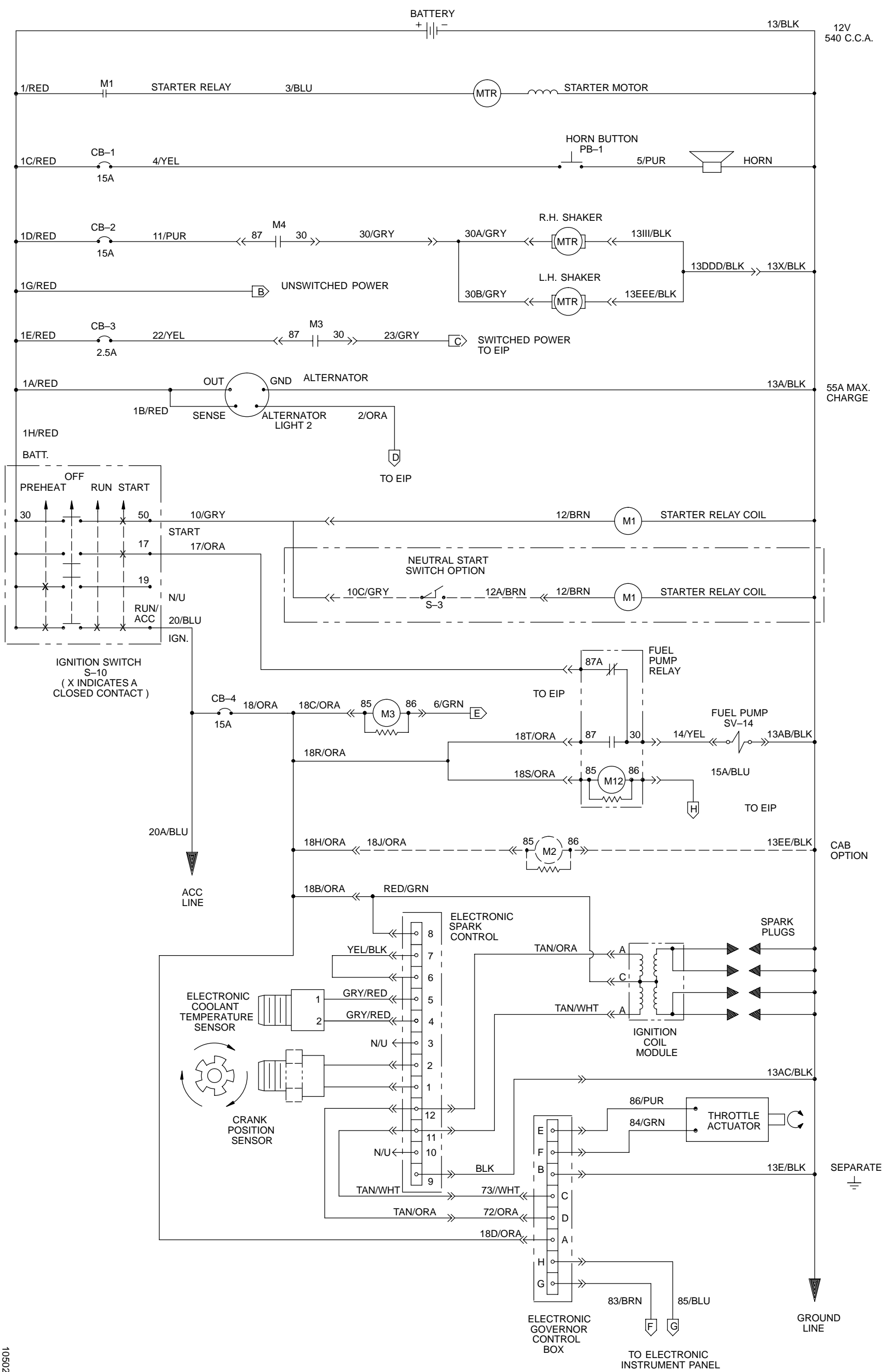
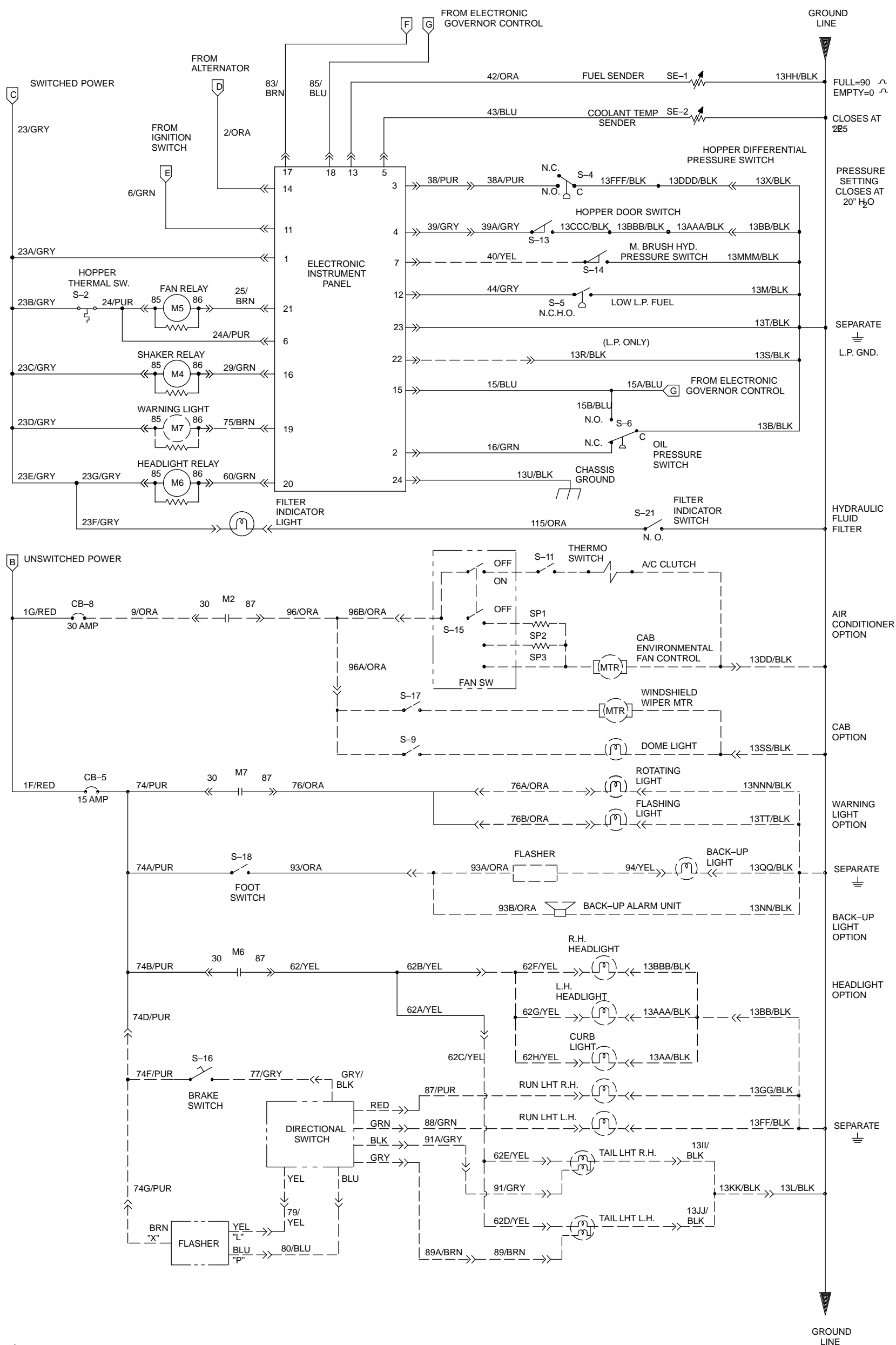

Fig. 86 - Electrical Schematic (For machines serial number 1700 and above)



10502

Fig. 86 - Electrical Schematic (For machines serial number 1700 and above)

STANDARD PARTS

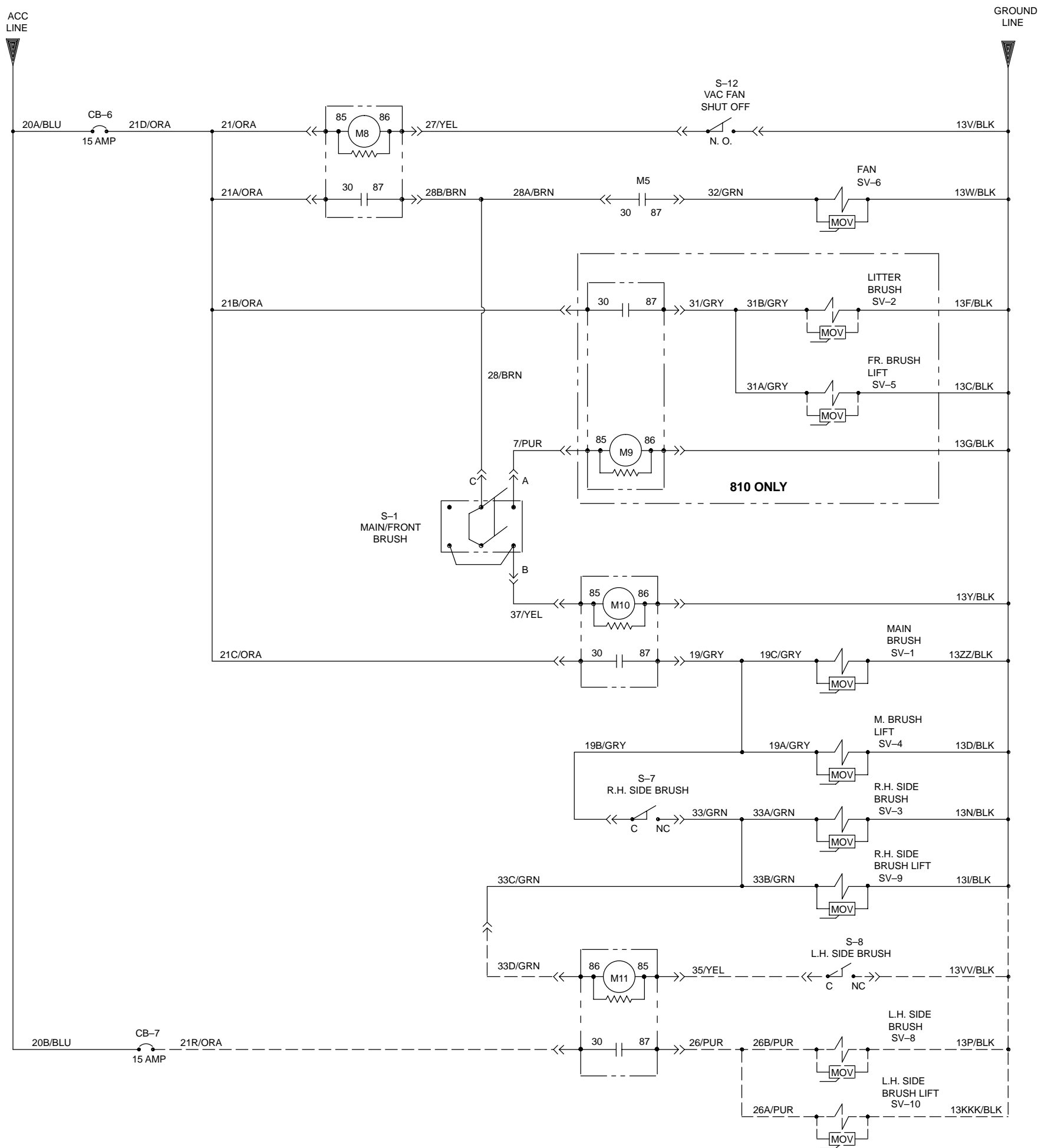

LEGEND			
M	POWER RELAY	HM	HOURLMETER
MTR	MOTOR	SV	SOLENOID VALVE
CB	CIRCUIT BREAKER	S	SWITCH
PM	PERMANENT MAGNET	ACC	ACCESSORY
J	JACK-FEM. SOCKET	GND	GROUND CHASSIS
P	PLUG-MALE PIN	C	COMMON
PB	PUSHBUTTON	N.O.	NORMALLY OPEN
VM	VOLTMETER	N.C.	NORMALLY CLOSED
FU	FUSE	NOV	METAL OXIDE VARISTOR

Fi 86 Electrical Schematic
For machines serial number 1700 and above

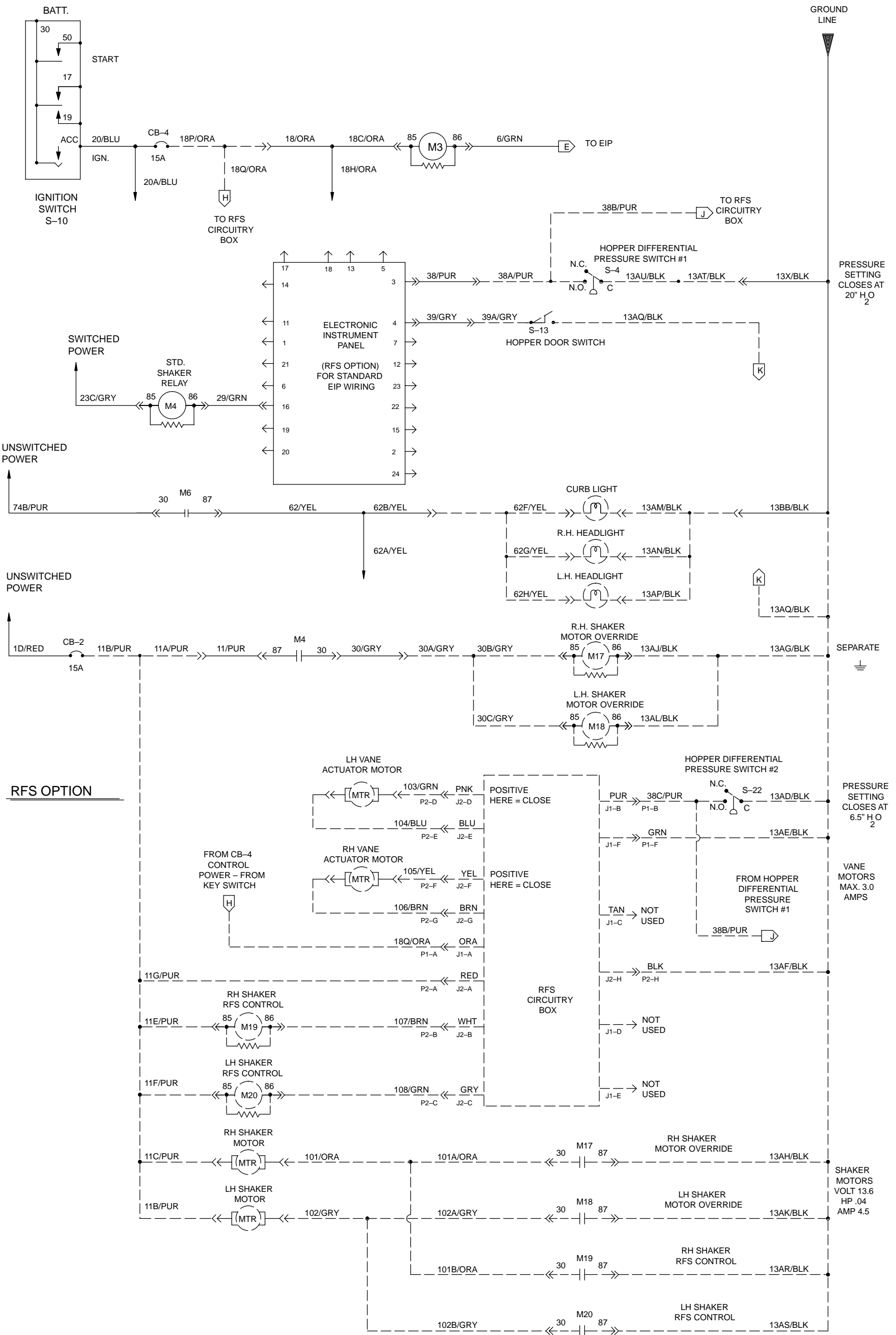

RFS OPTION

Fi 86 Electrical Schematic For machines serial number 1700 and above

Fig. 87 – Wire Harnesses Group
(For machines below serial number 1700)

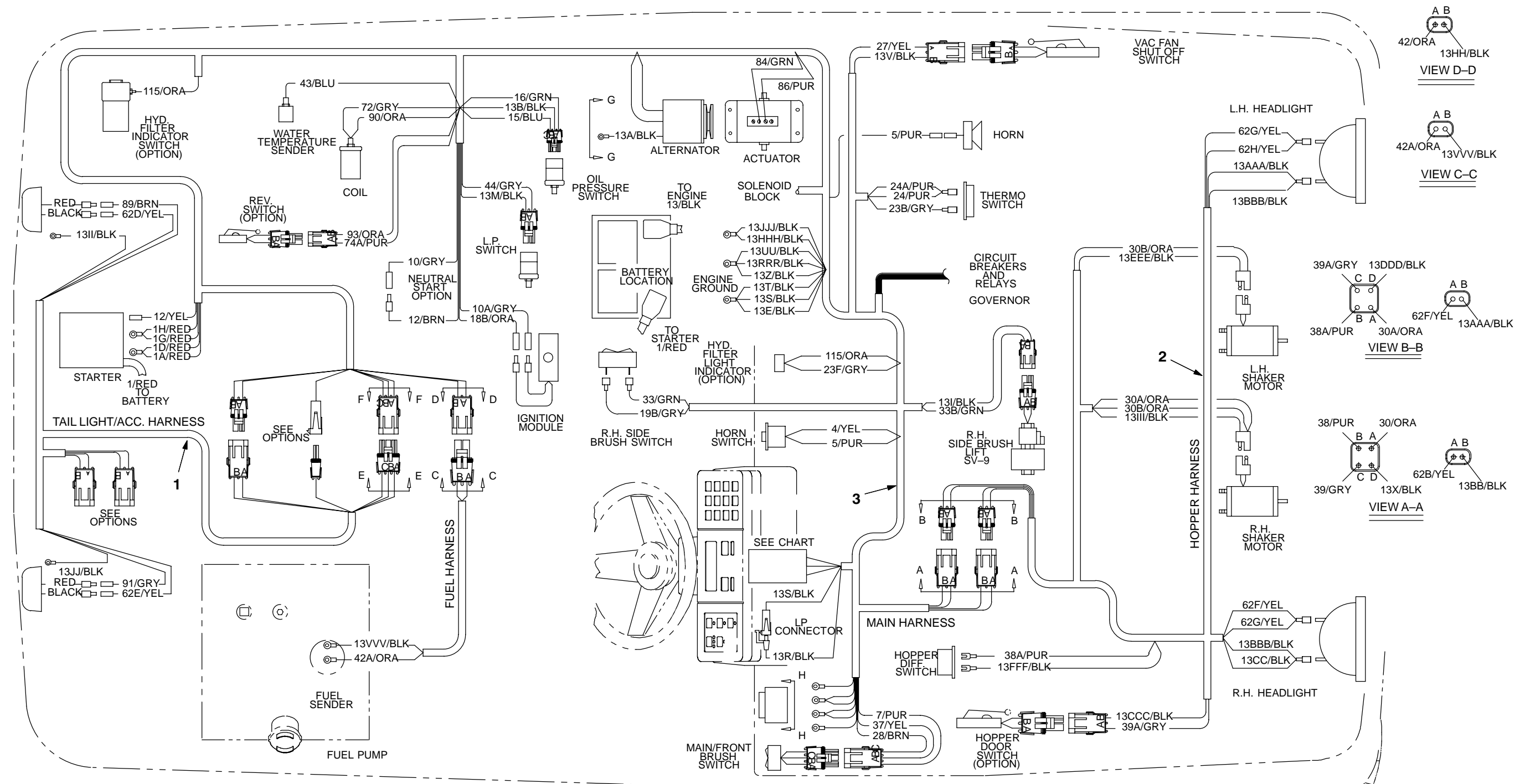

SOCKET NO.	WIRE NO.	COLOR	SOCKET NO.	WIRE NO.	COLOR	SOCKET NO.	WIRE NO.	COLOR	SOCKET NO.	WIRE NO.	COLOR
1	23A	GRY	7	40	YEL	13	42	ORA	19	75	BRN
2	16	GRN	8	PLUG	---	14	2	ORA	20	60	GRN
3	38	PUR	9	PLUG	---	15	15	BLU	21	25	BRN
4	39	GRY	10	PLUG	---	16	29	GRN	22	13R	BLK
5	43	BLU	11	6	GRN	17	83	BRN	23	13T	BLK
6	24A	PUR	12	44	GRY	18	85	BLU	24	13U	BLK

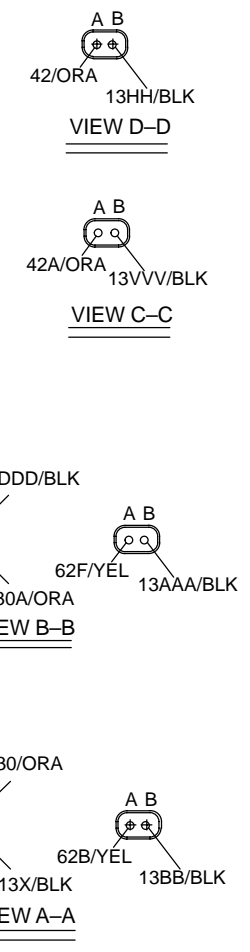
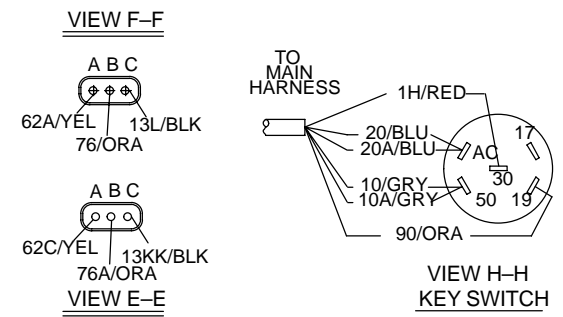

STANDARD PARTS

Fi 87 Wire Harness Group
For machines below serial number 1700

RELAYS

- M3 ELECTRONIC INSTRUMENT PANEL
- M4 SHAKER MOTOR
- M5 VAC FAN SOLENOID
- M6 HEADLIGHTS
- M7 ROTATING/FLASHING LIGHTS
- M8 HOPPER LIFT
- M9 FRONT BRUSH
- M10 MAIN BRUSH

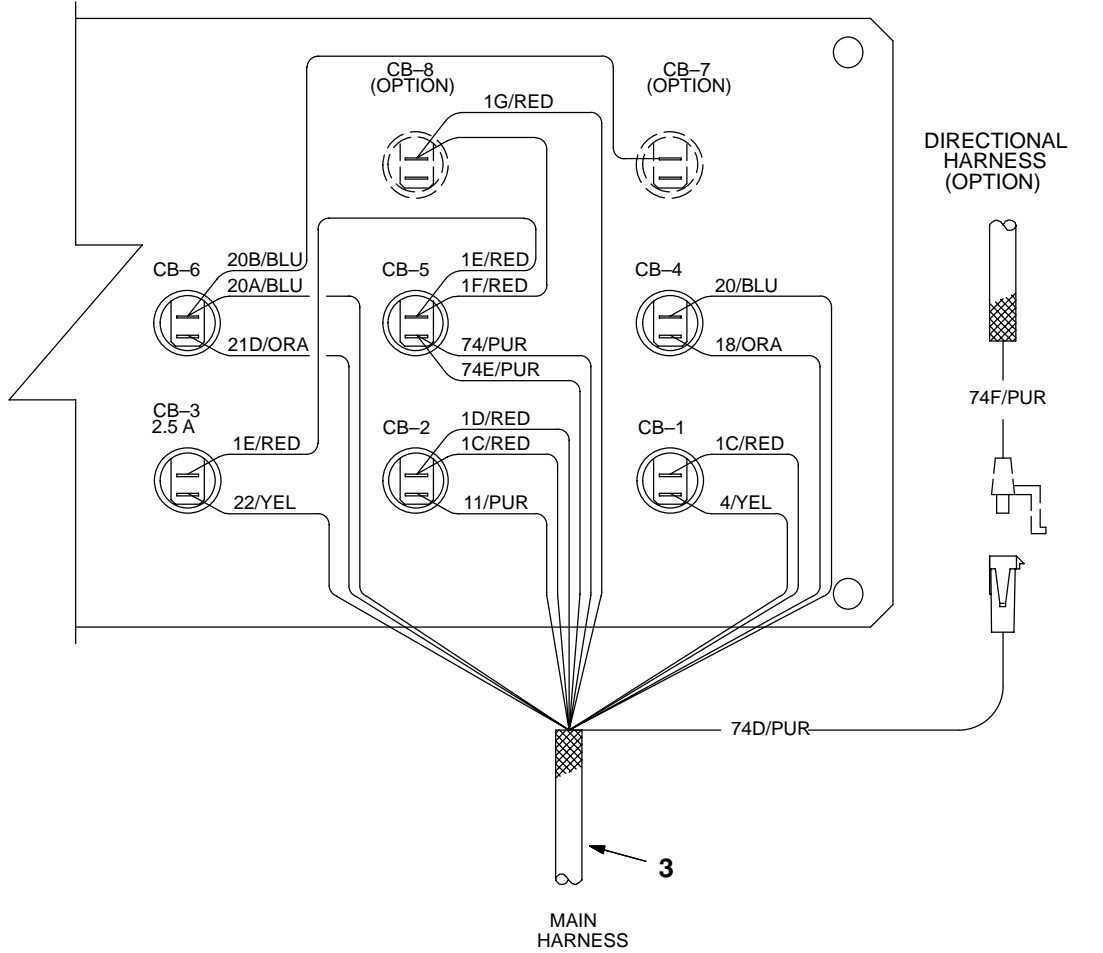
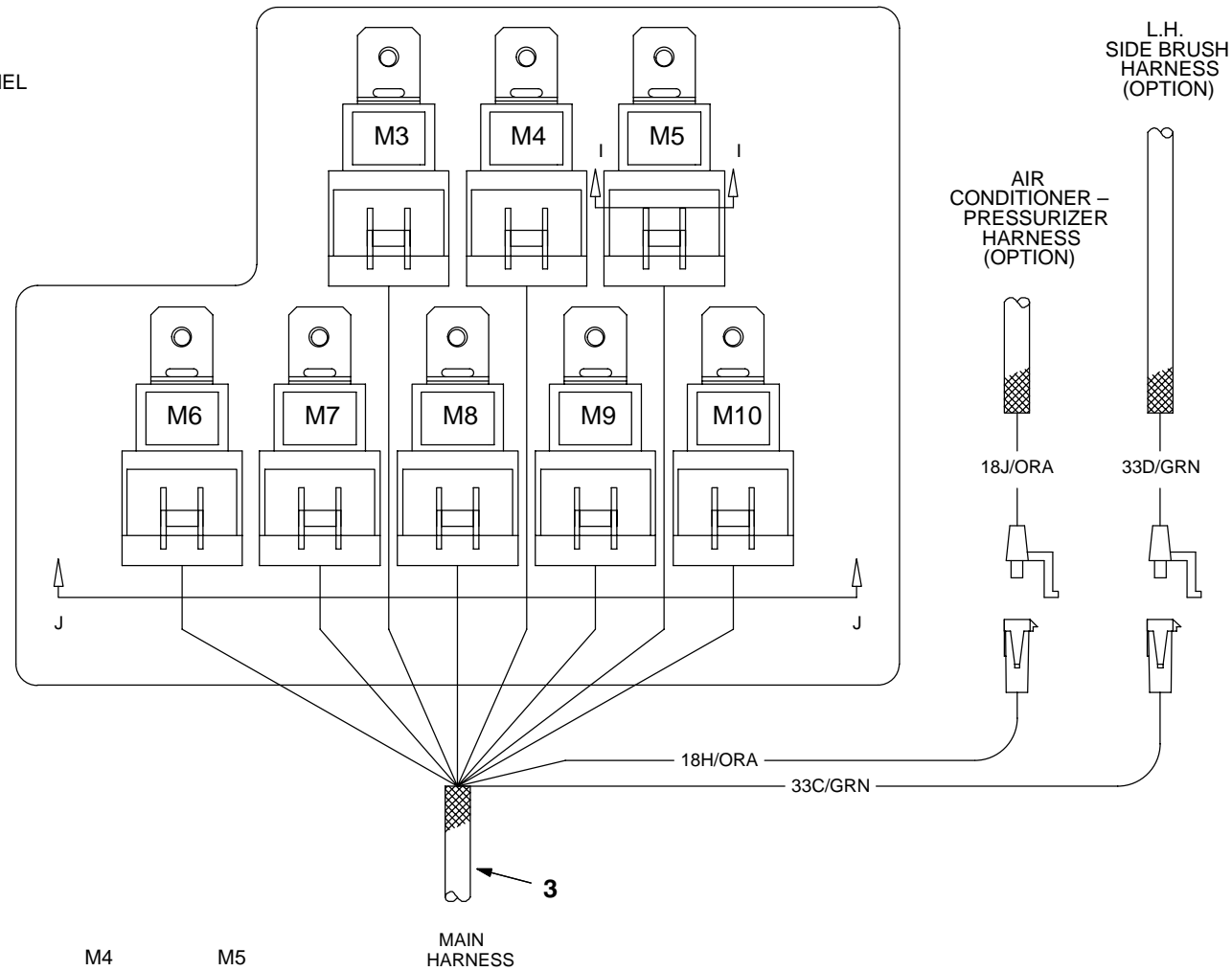

CIRCUIT BREAKERS

- CB-1 HORN
- CB-2 SHAKER MOTOR
- CB-3 VAC FAN RELAY, SHAKER RELAY, WARNING LIGHT & HEADLIGHT
- CB-4 ELECTRONIC INSTRUMENT PANEL
- CB-5 ROTATING LIGHT & BACK-UP ALARM
- CB-6 HOPPER LIFT RELAY, FRONT/MAIN BRUSH
- CB-7 LEFT HAND SIDE BRUSH
- CB-8 CAB ACCESSORIES

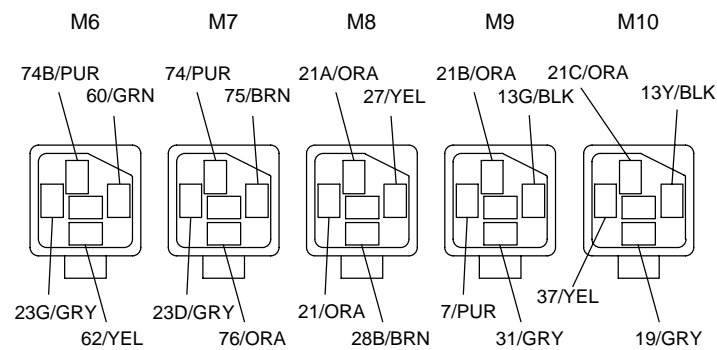
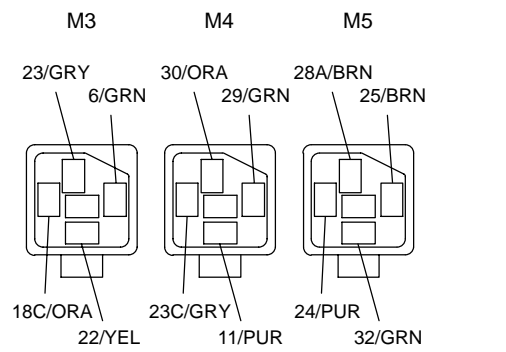

VIEW J-J

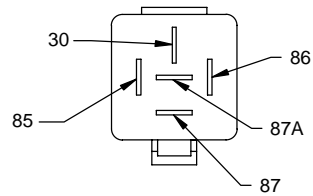

- 85 COIL+
- 86 COIL-
- 30 COMMON CONTACT
- 87 N.O. CONTACT
- 87A N.C. CONTACT

SECTION I-I

Fi 87 Wire Harnesses Group
For machines below serial number 1700

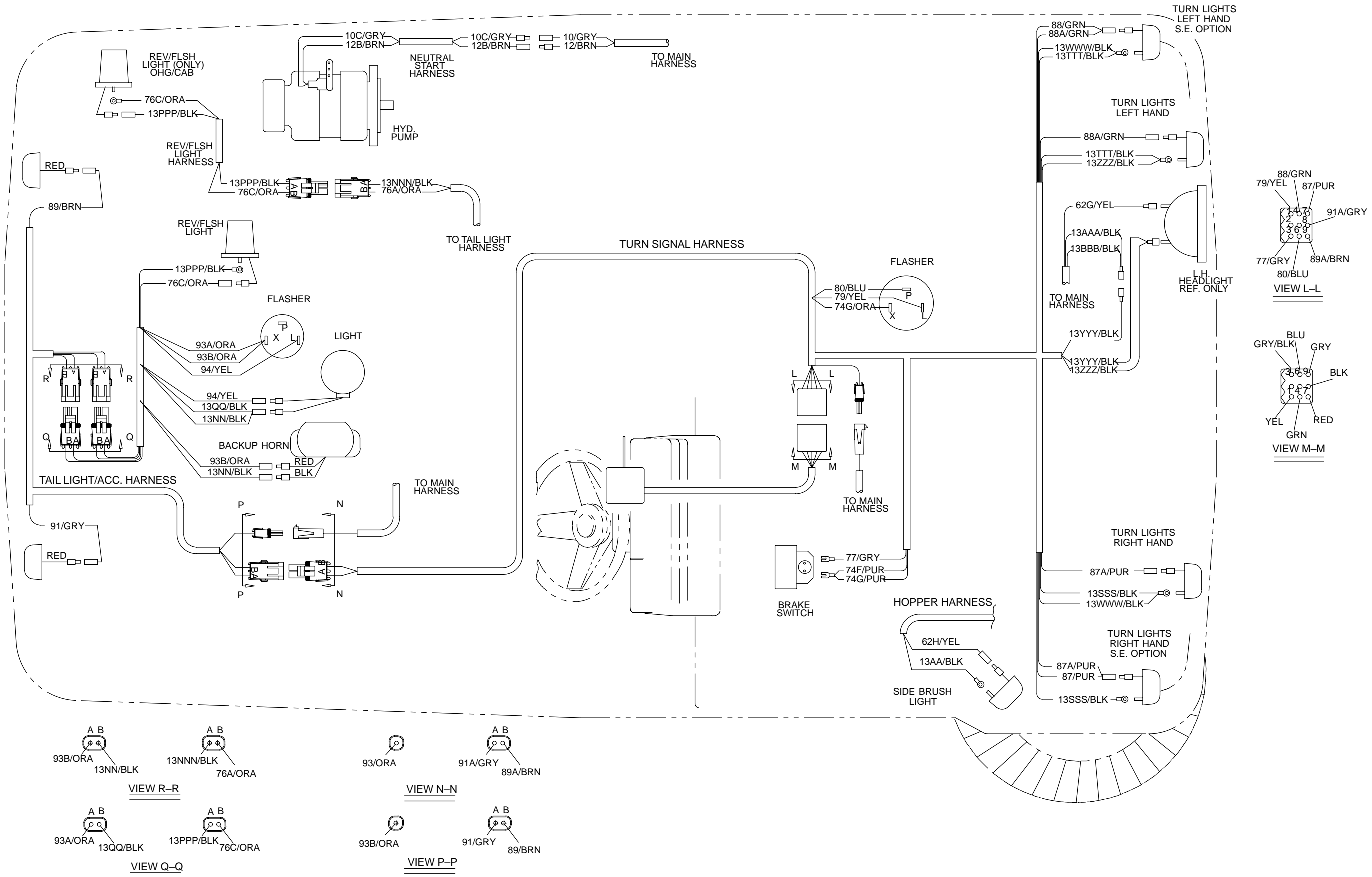

STANDARD PARTS

Fi 87 Wire Harnesses Group For machines below serial number 1700

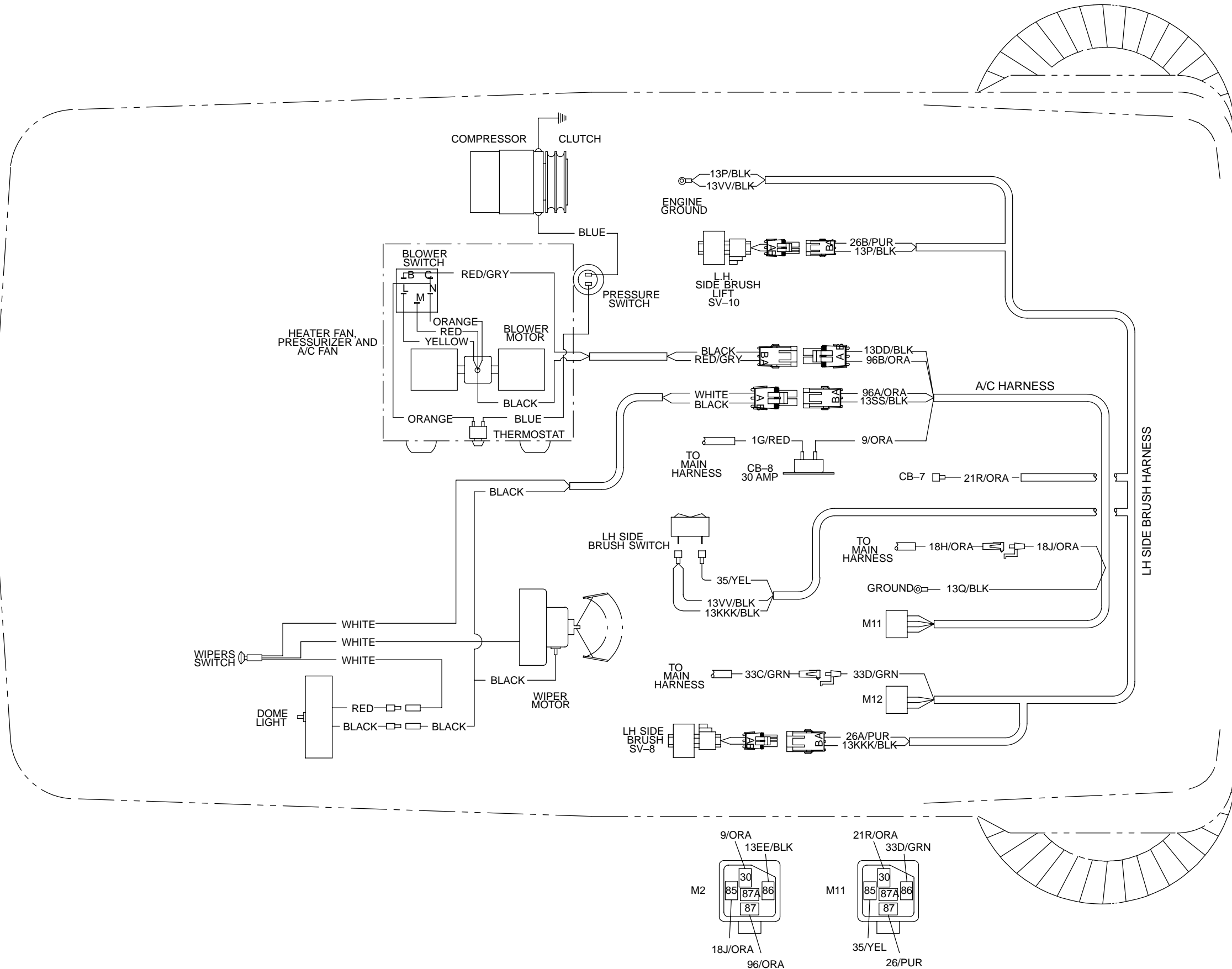

Fi 87 Wire Harnesses Group
For machines below serial number 1700

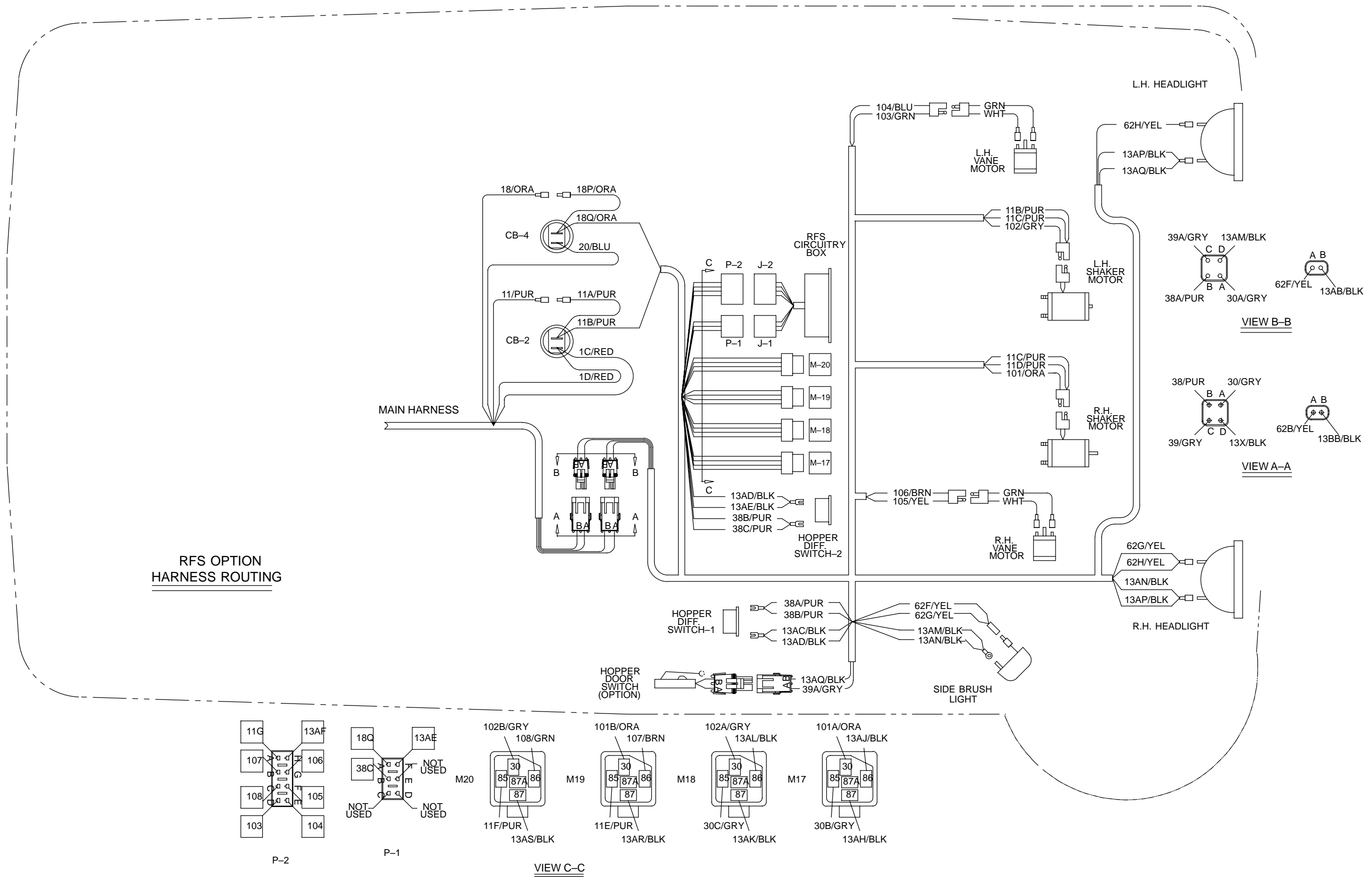

**Fig. 87 – Wire Harnesses Group
(For machines below serial number 1700)**

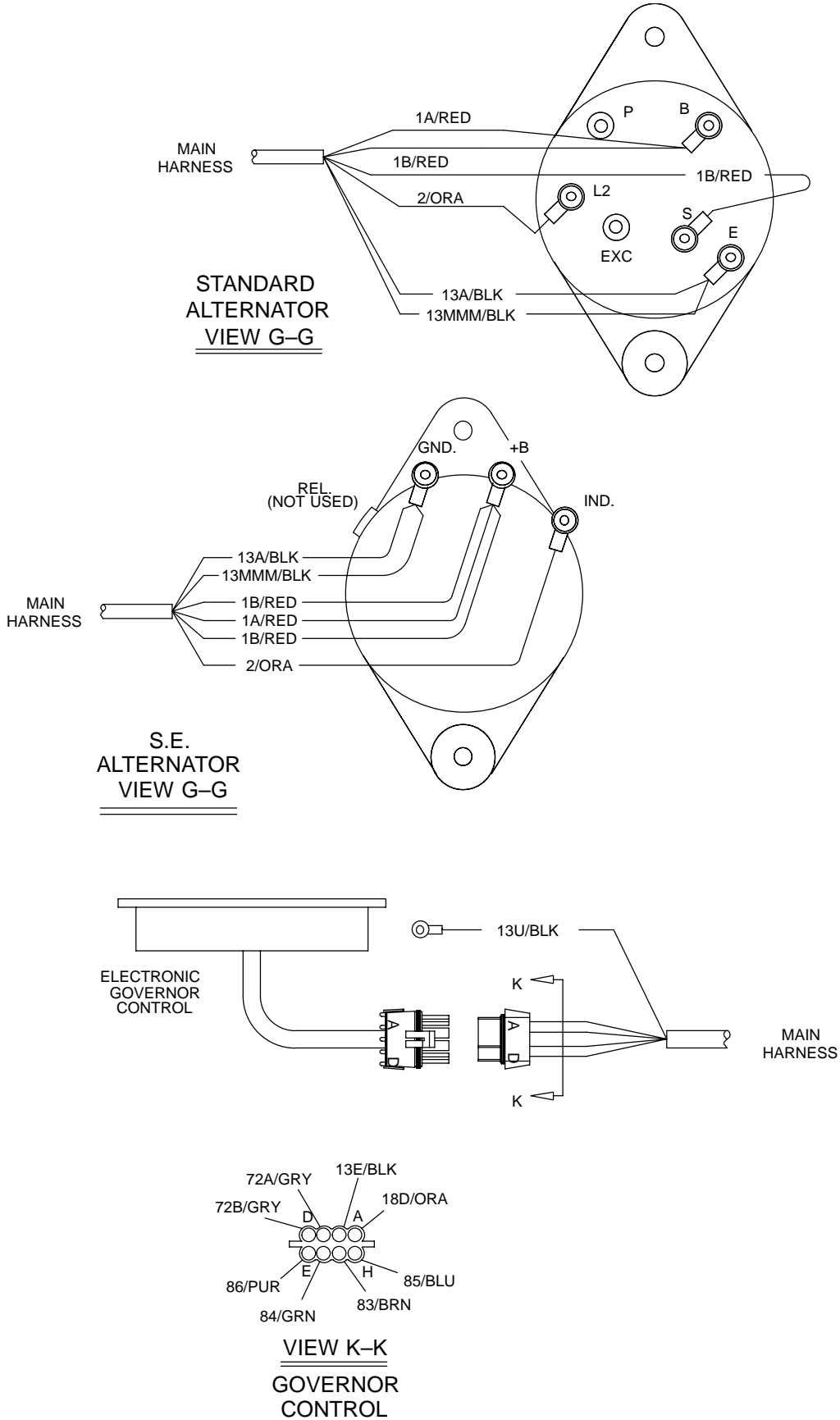

**Fig. 87 – Wire Harnesses Group
(For machines below serial number 1700)**

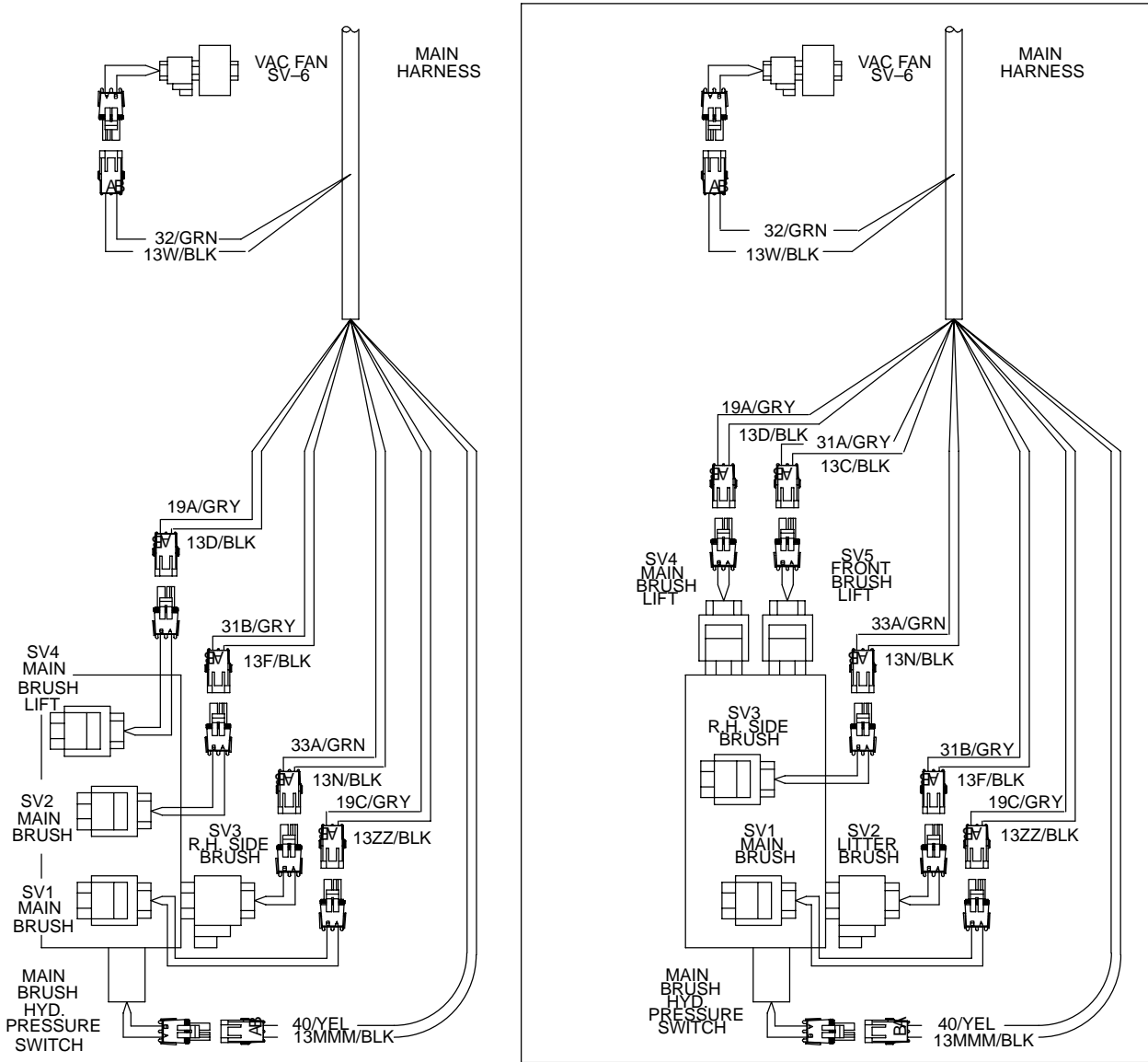

810
MODEL
ONLY

08773/09919

Ref.	Tennant Part No.	Machine Serial Number	Description	Qty.
1	70400	(000000–001699)	Harness, Turn/Rotate/Tail Lights	1
2	63417	(000000–001699)	Harness, Hopper	1
3	77745	(000000–001699)	Harness, Main, Gas/LPG, Lsg	1

STANDARD PARTS

Fig. 88 – Wire Harnesses Group
(For machines serial number 1700 and above)

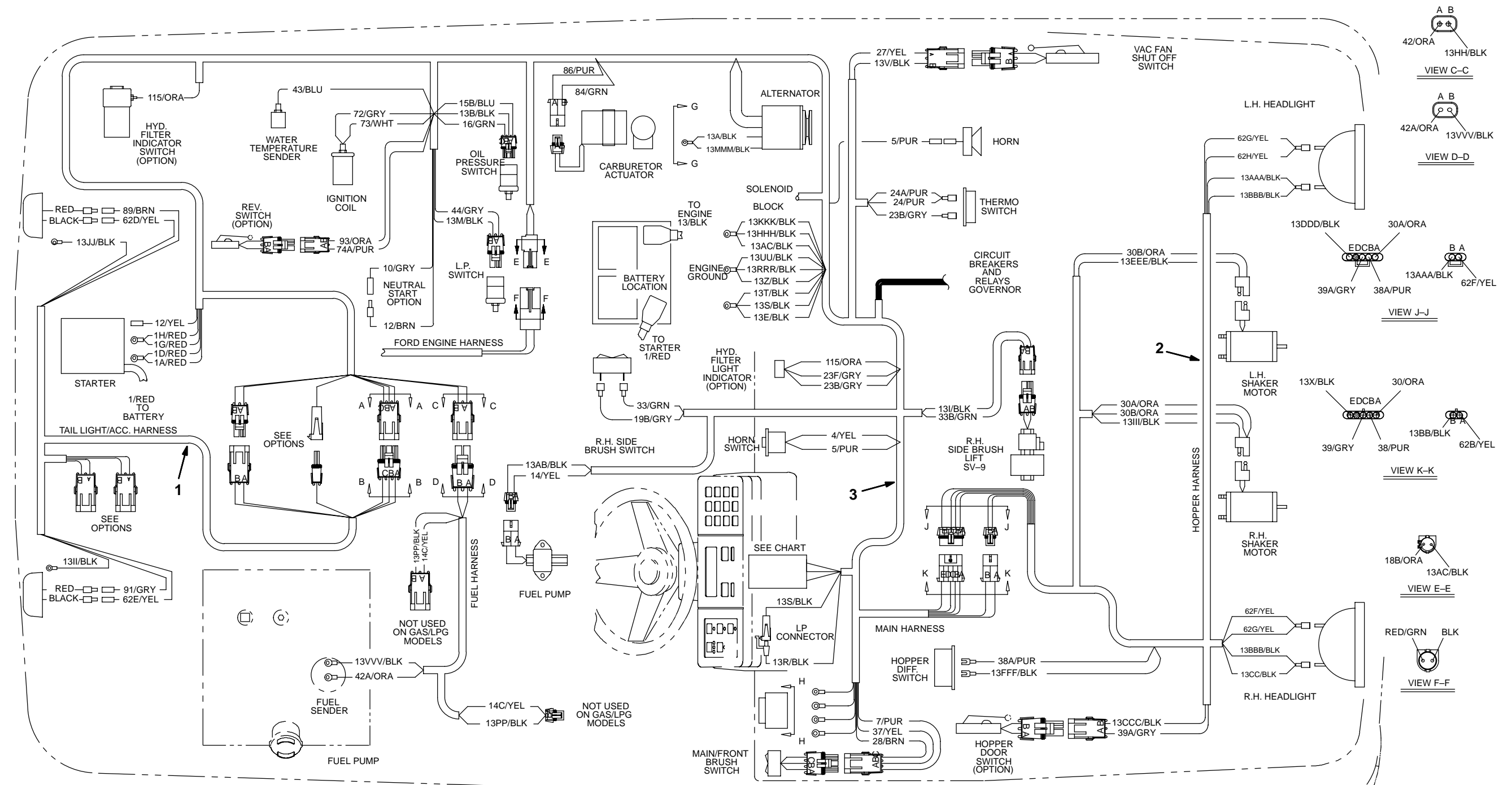

SOCKET NO.	WIRE NO.	COLOR	SOCKET NO.	WIRE NO.	COLOR	SOCKET NO.	WIRE NO.	COLOR	SOCKET NO.	WIRE NO.	COLOR
1	23A	GRY	7	40	YEL	13	42	ORA	19	75	BRN
2	16	GRN	8	PLUG	—	14	2	ORA	20	60	GRN
3	38	PUR	9	PLUG	—	15	15	BLU	21	25	BRN
4	39	GRY	10	PLUG	—	16	29	GRN	22	13R	BLK
5	43	BLU	11	6	GRN	17	83	BRN	23	13T	BLK
6	24A	PUR	12	44	GRY	18	85	BLU	24	13U	BLK

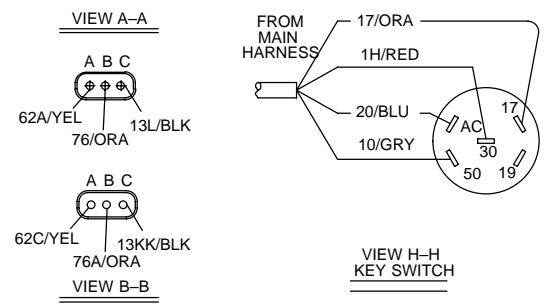

Fi 88 Wire Harnesses Group
For machines serial number 1700 and above

- RELAYS
- M3 ELECTRONIC INSTRUMENT PANEL
 - M4 SHAKER MOTOR
 - M5 VAC FAN SOLENOID
 - M6 HEADLIGHTS
 - M7 ROTATING/FLASHING LIGHTS
 - M8 HOPPER LIFT
 - M9 FRONT BRUSH
 - M10 MAIN BRUSH
 - M12 FUEL PUMP

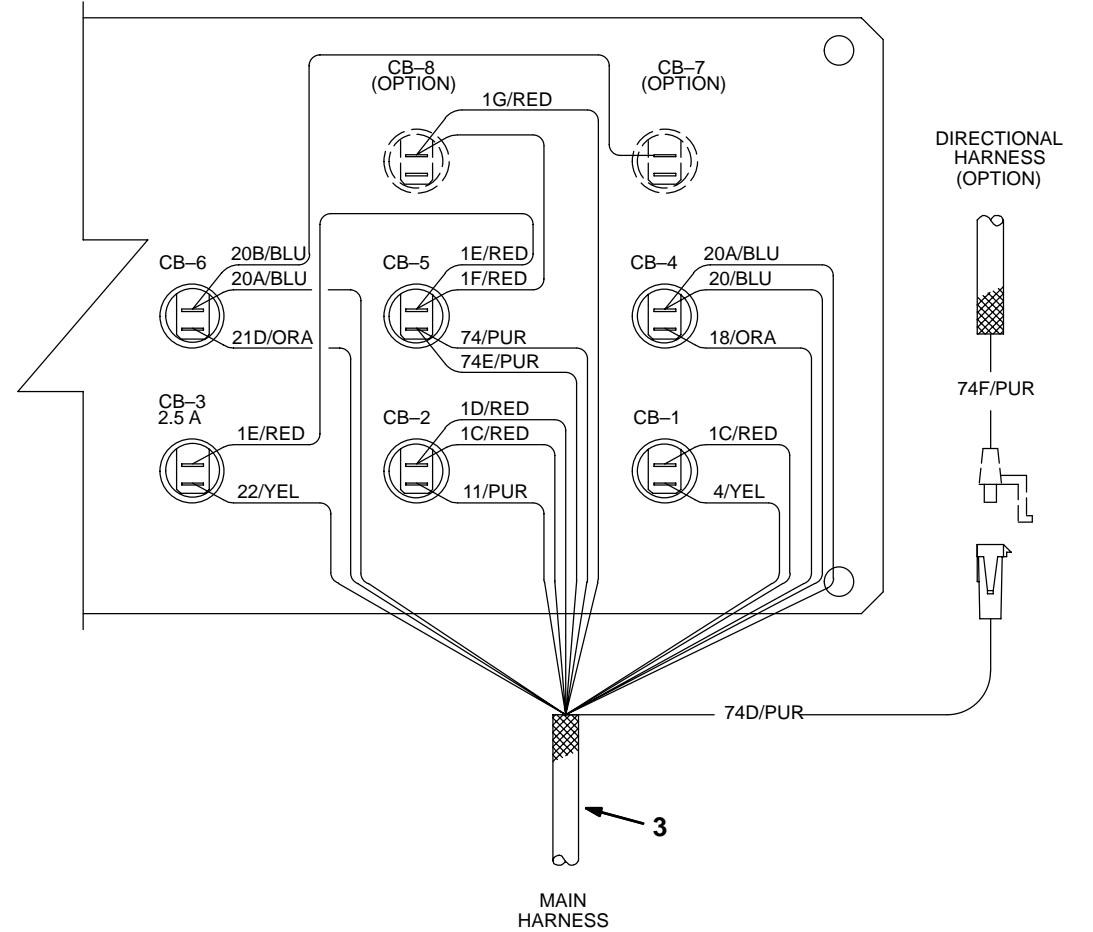
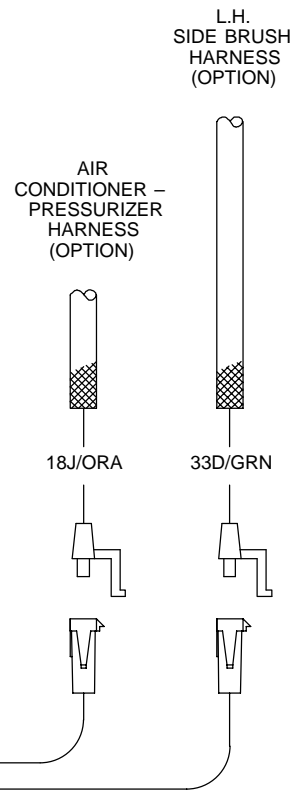
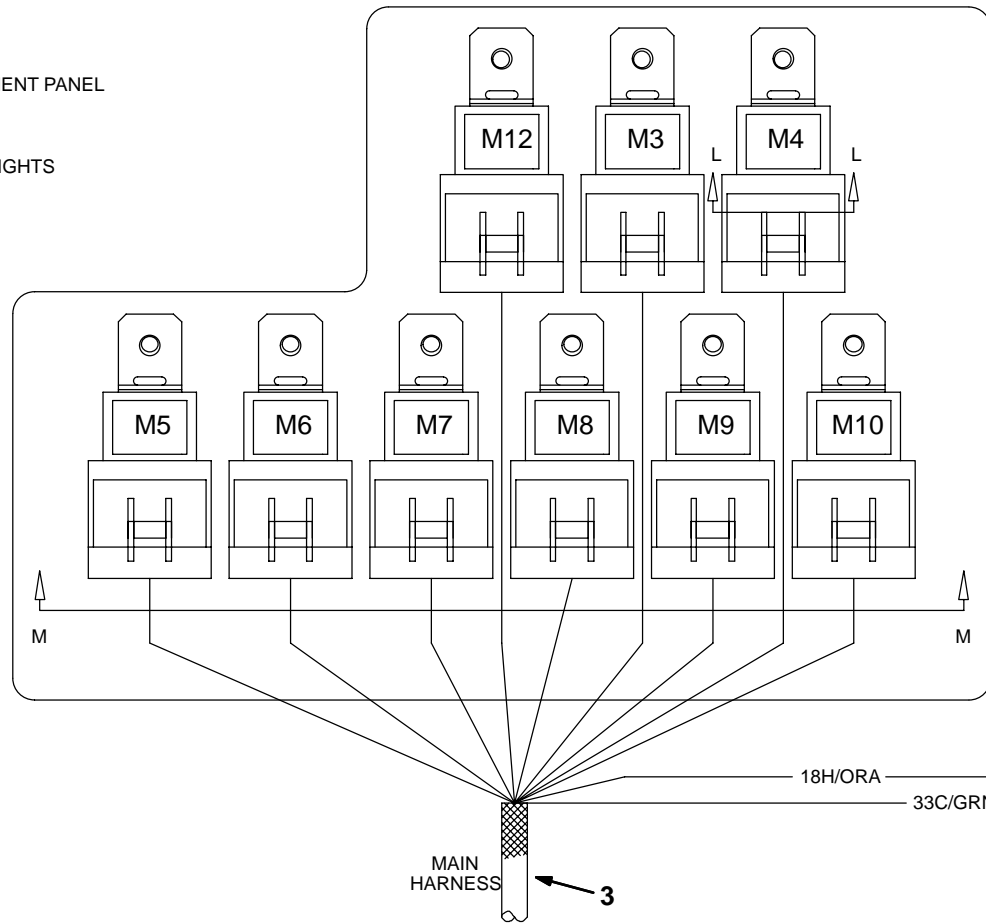

CIRCUIT BREAKERS

- CB-1 HORN
- CB-2 SHAKER MOTOR
- CB-3 VAC FAN RELAY, SHAKER RELAY, WARNING LIGHT & HEADLIGHT
- CB-4 ELECTRONIC INSTRUMENT PANEL
- CB-5 ROTATING LIGHT & BACK-UP ALARM
- CB-6 HOPPER LIFT RELAY, FRONT/MAIN BRUSH
- CB-7 LEFT HAND SIDE BRUSH
- CB-8 CAB ACCESSORIES

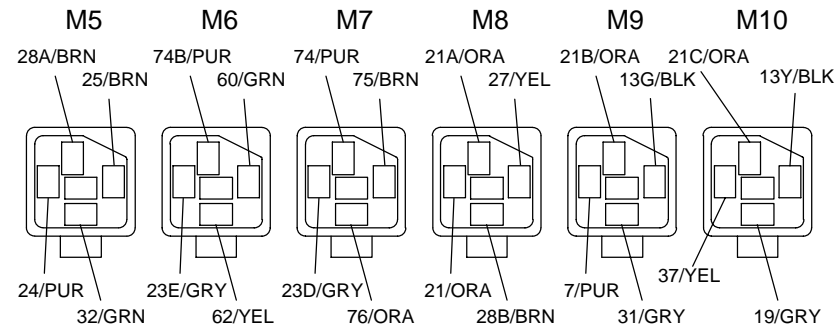
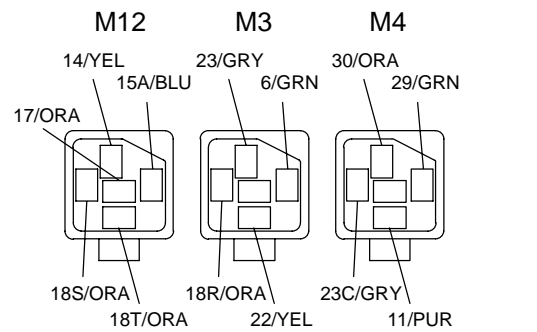

VIEW M-M

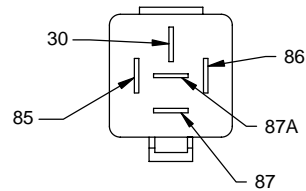

- 85 COIL+
- 86 COIL-
- 30 COMMON CONTACT
- 87 N.O. CONTACT
- 87A N.C. CONTACT

SECTION L-L

STANDARD PARTS

Fi 88 Wire Harnesses Group For machines serial number 1700 and above

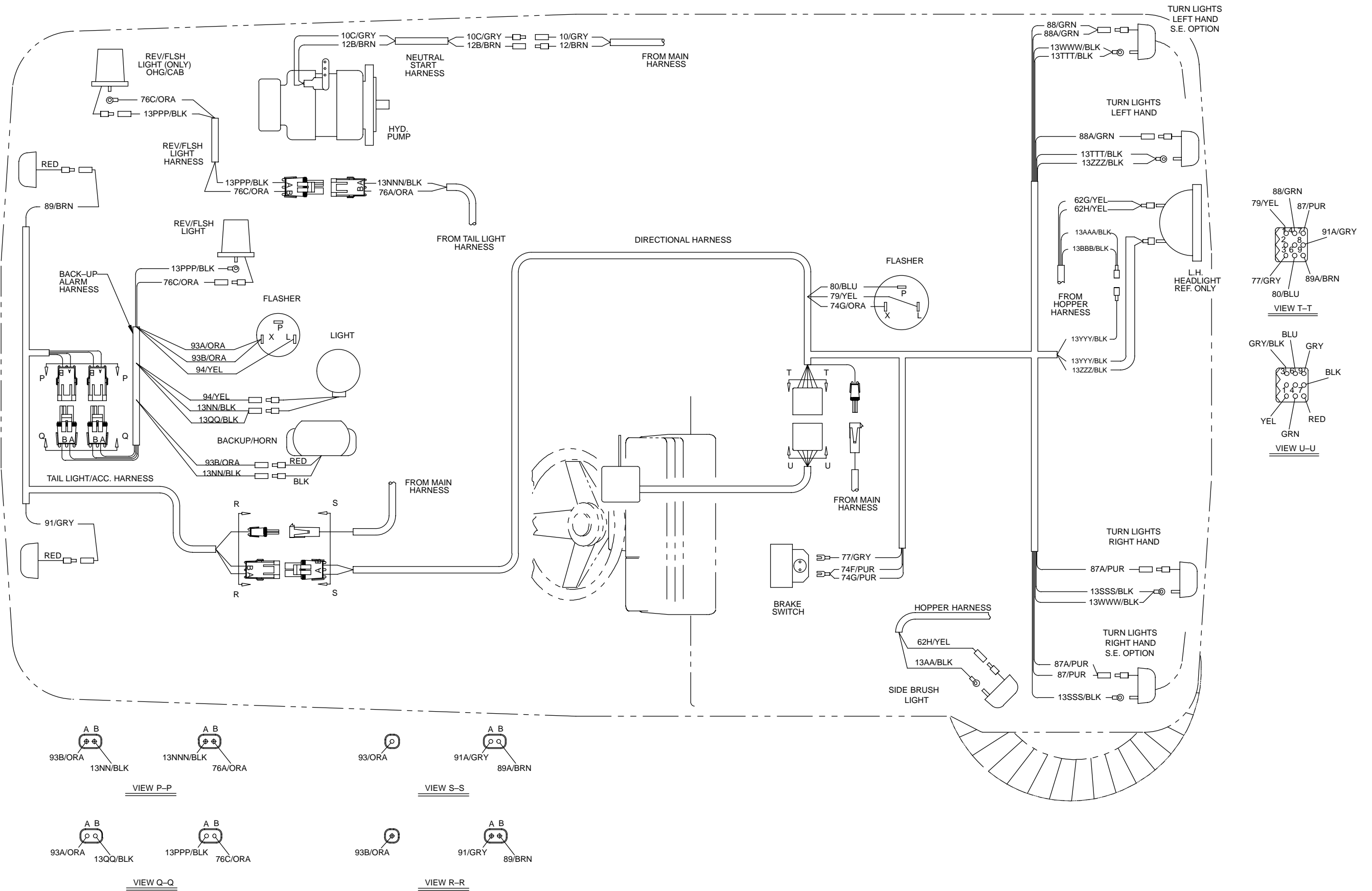

Fi 88 Wire Harnesses Group
For machines serial number 1700 and above

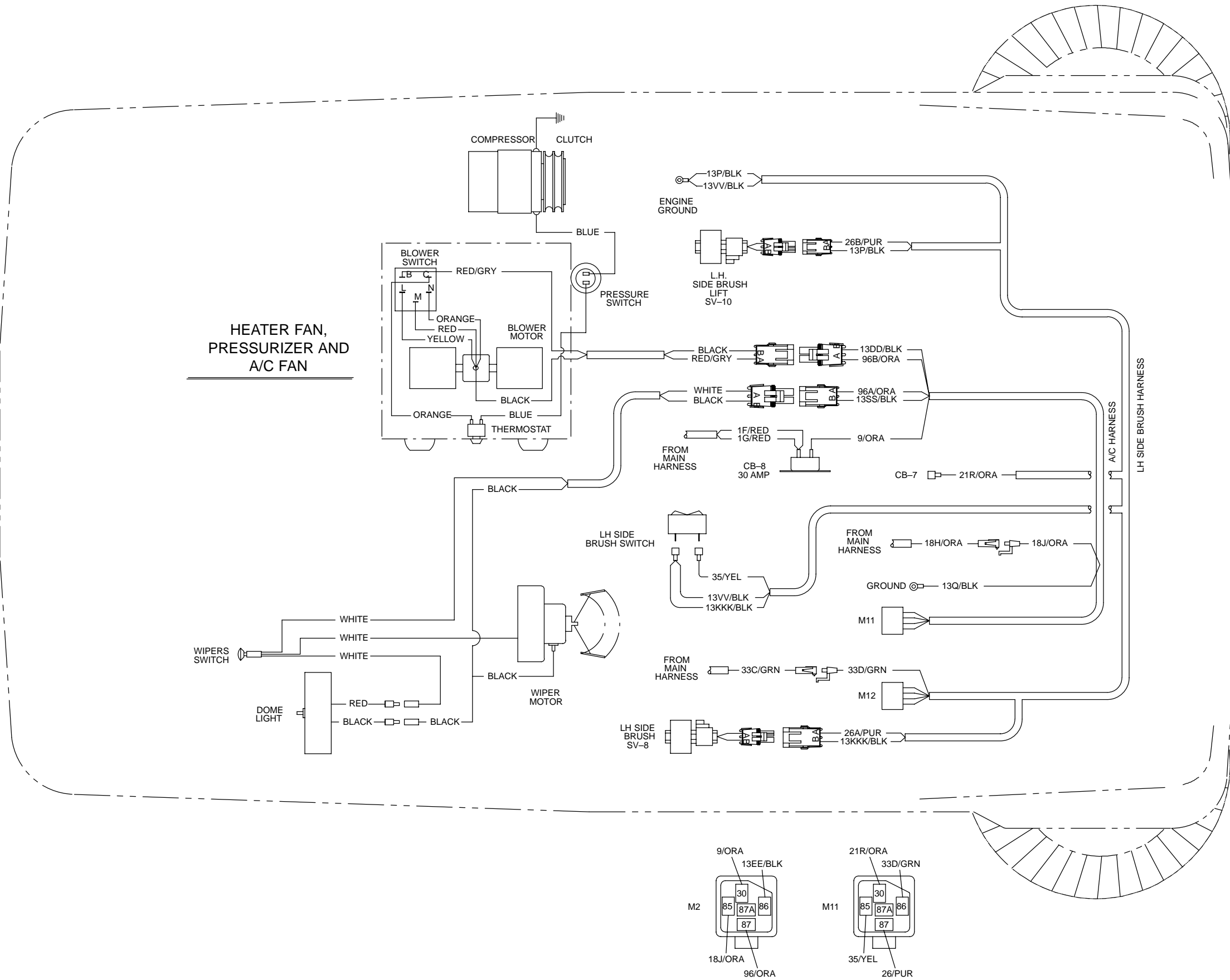

STANDARD PARTS

Fi 88 Wire Harnesses Group For machines serial number 1700 and above

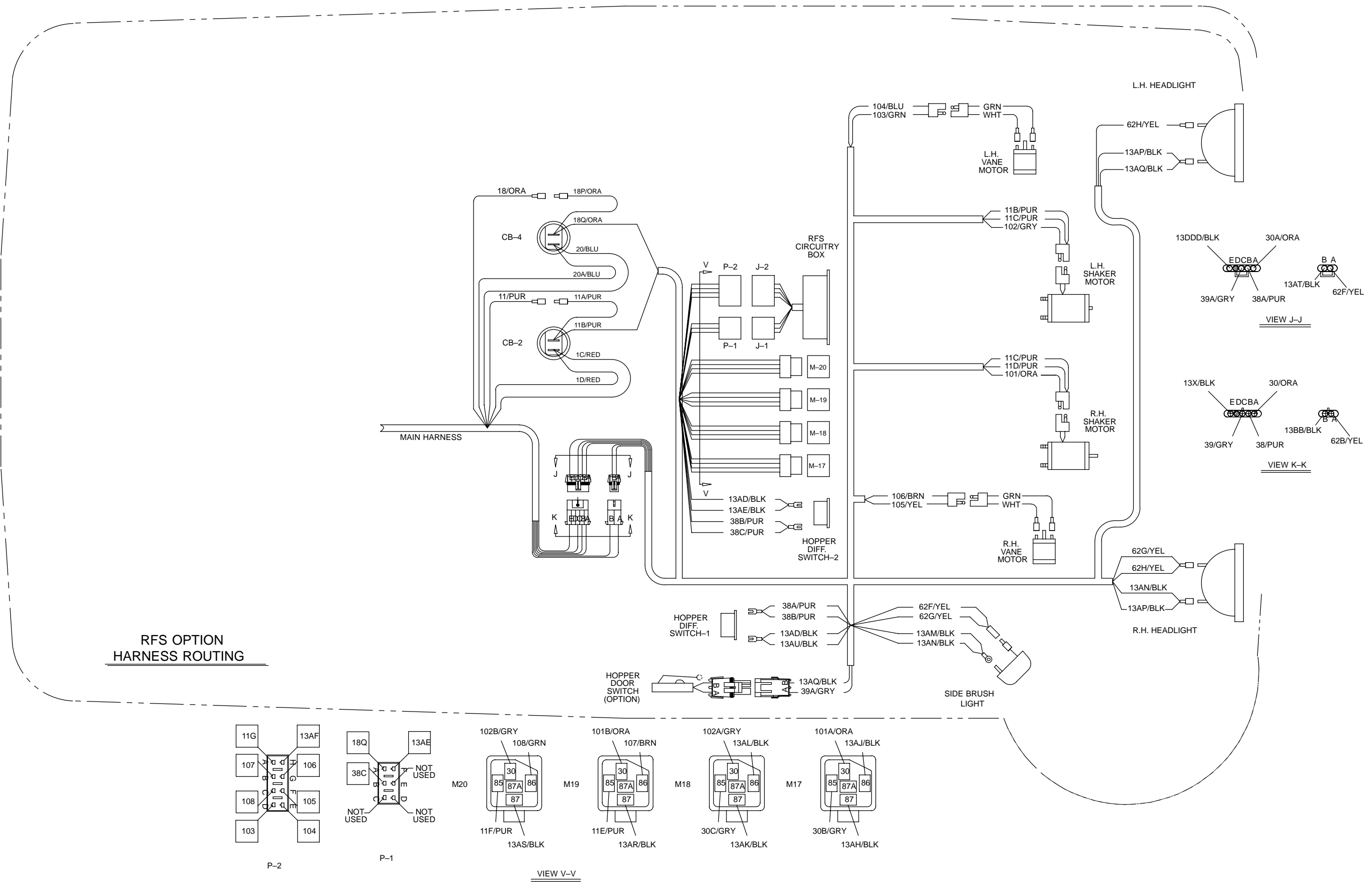

Fi 88 Wire Harnesses Group
For machines serial number 1700 and above

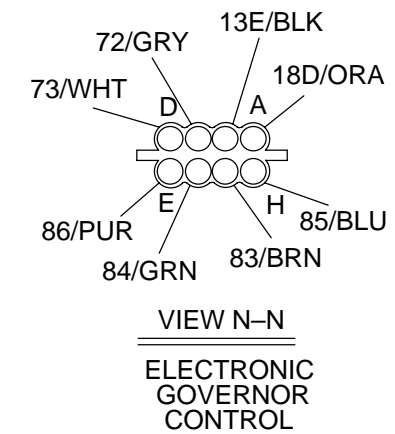
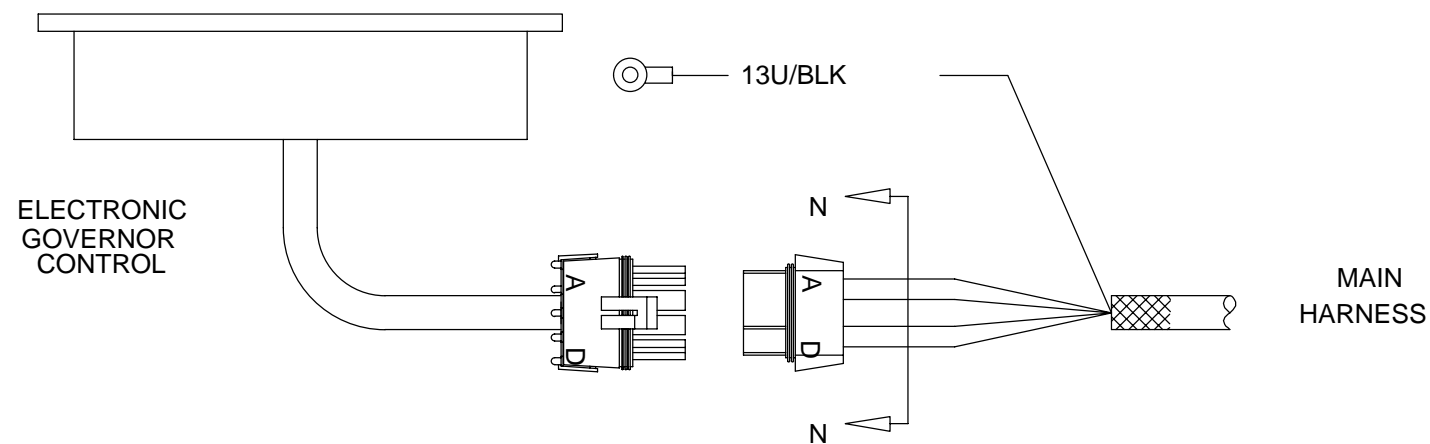
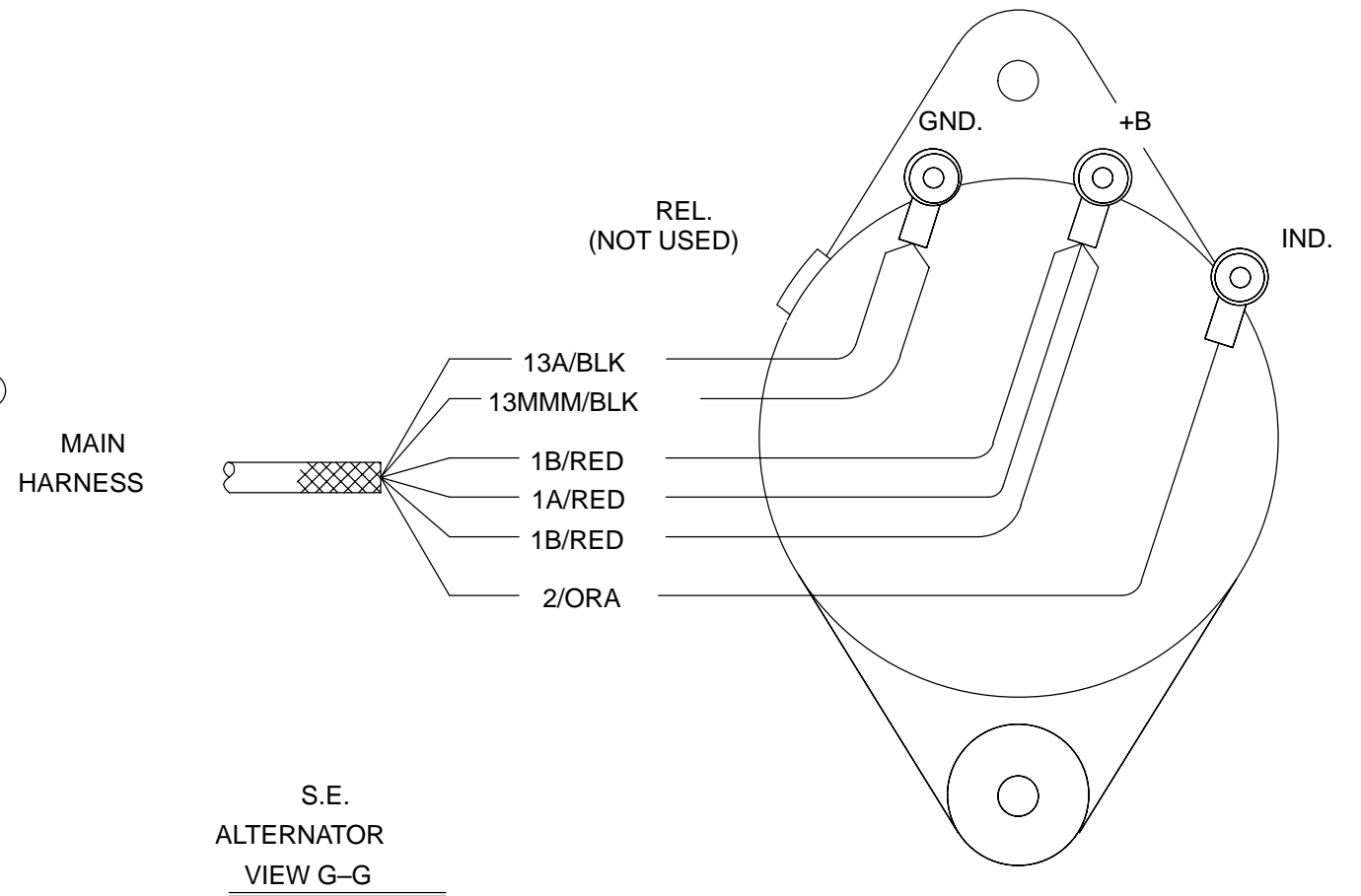
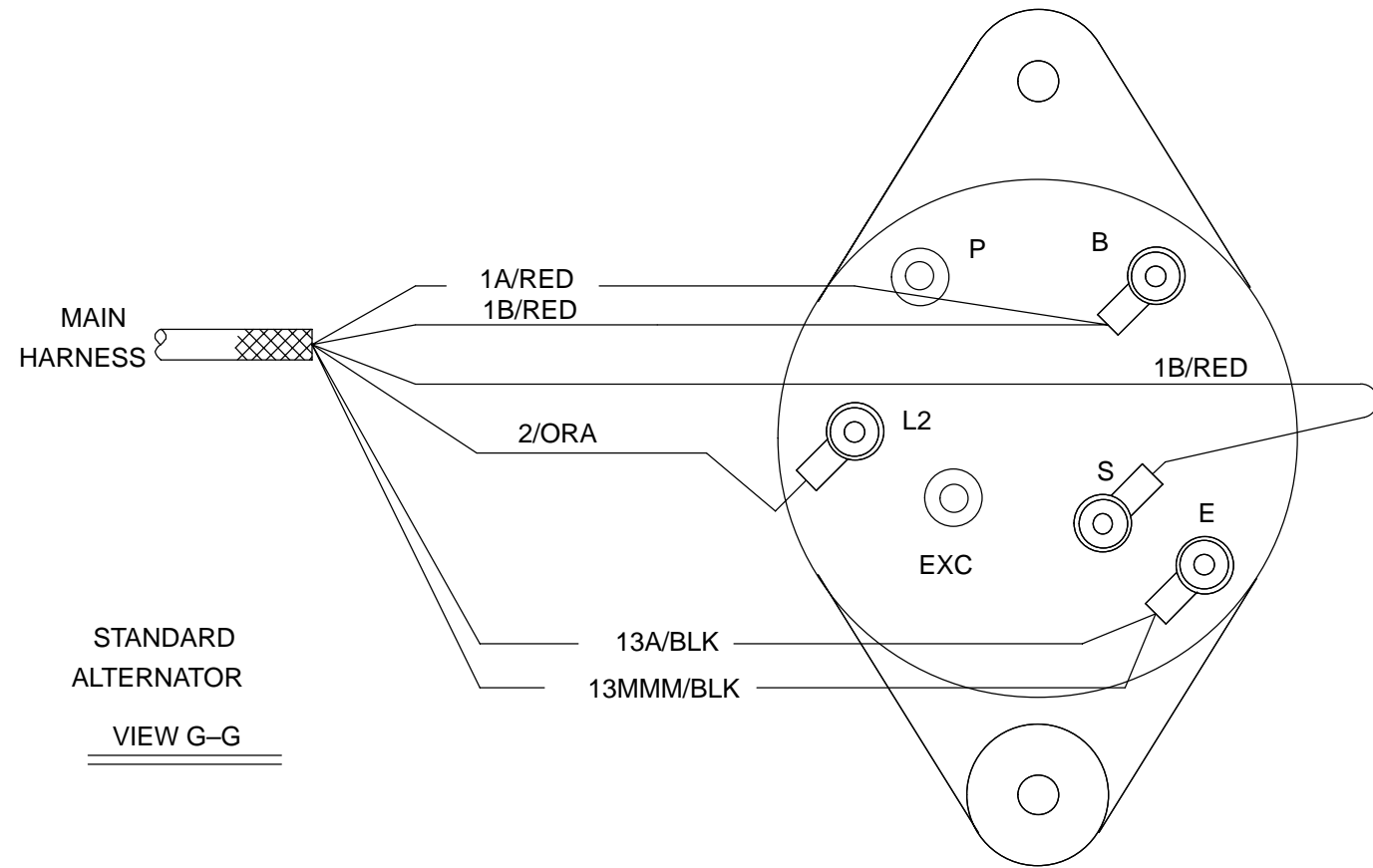

Fi 88 Wire Harnesses Group
For machines serial number 1700 and above

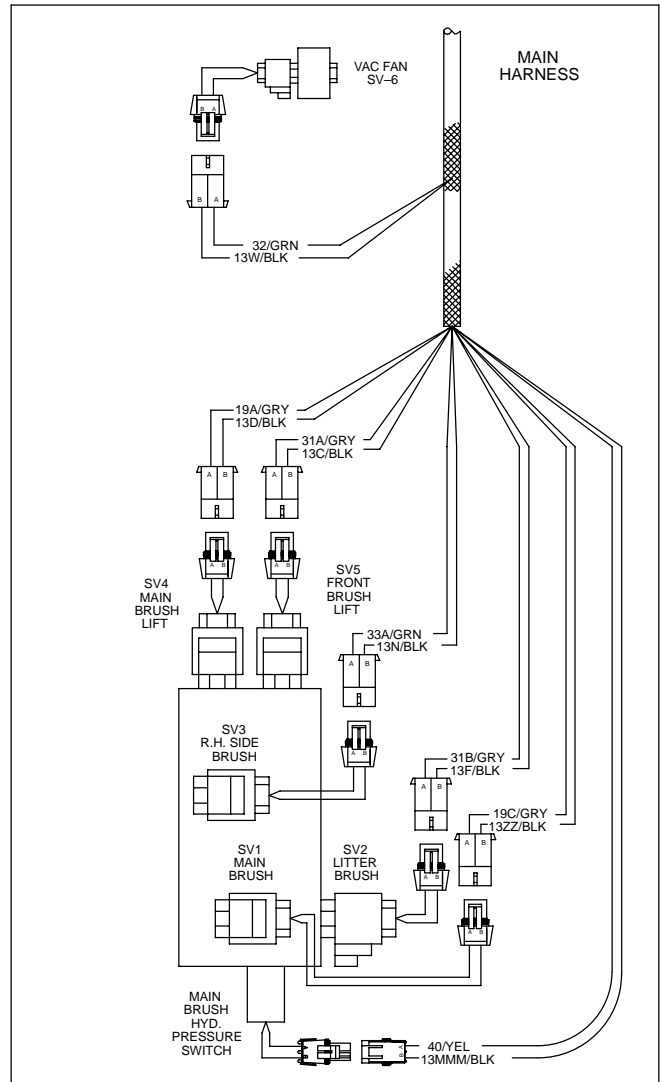
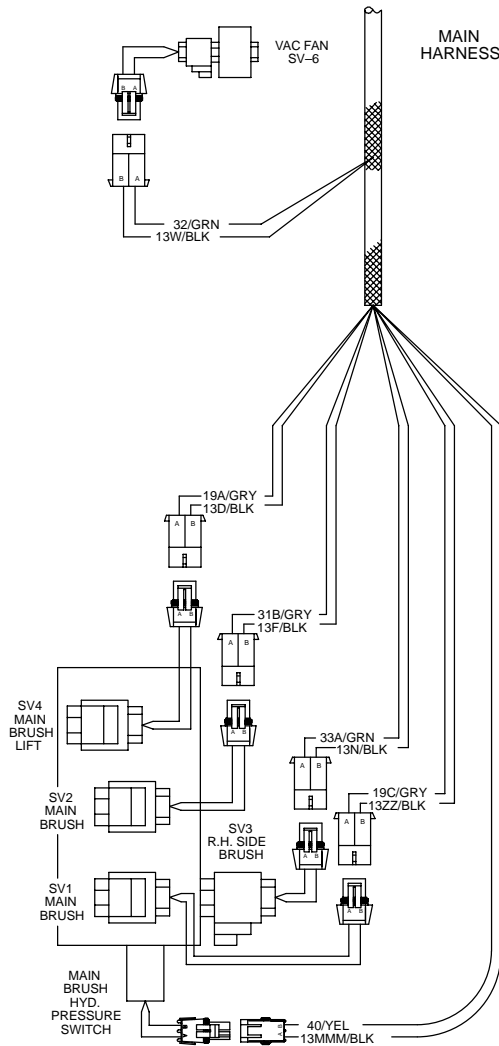

810
 MODEL
 ONLY

10503/10501

Ref.	Tennant Part No.	Machine Serial Number	Description	Qty.
1	70400	(001700–)	Harness, Turn/Rotate/Tail Lights	1
2	83695	(001700–)	Harness, Hopper 800/810	1
3	83693	(001700–)	Harness, Main, Gas/LPG, Lrg	1

Fig. 89 – Label Group

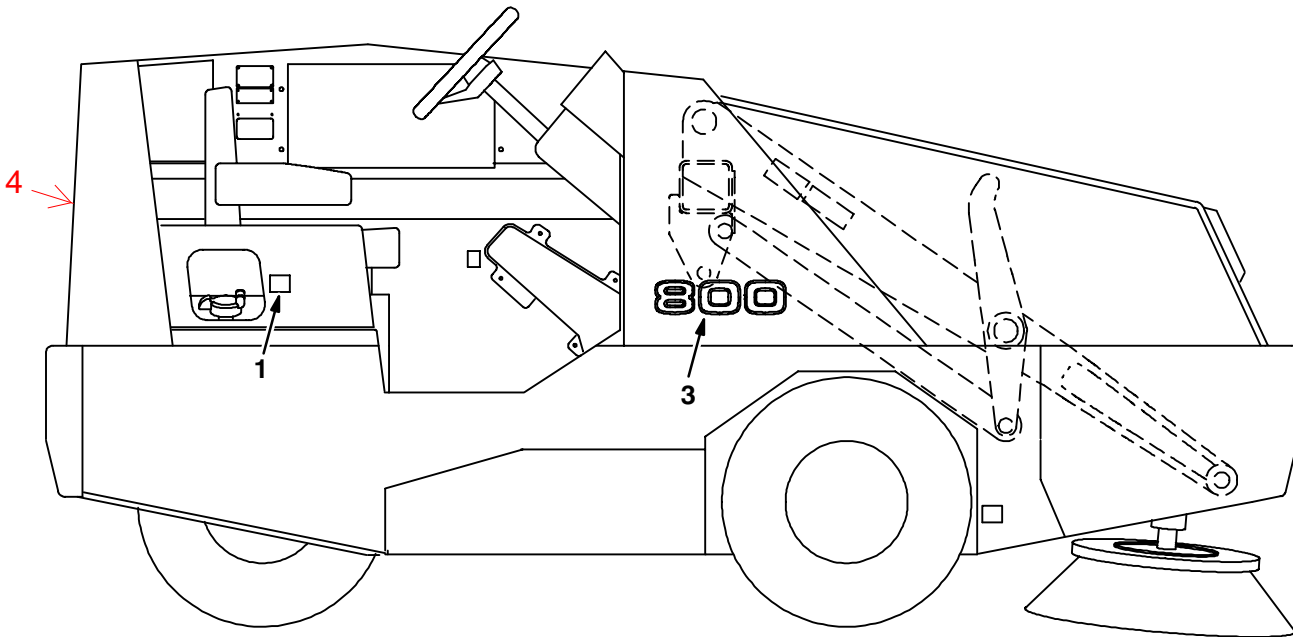
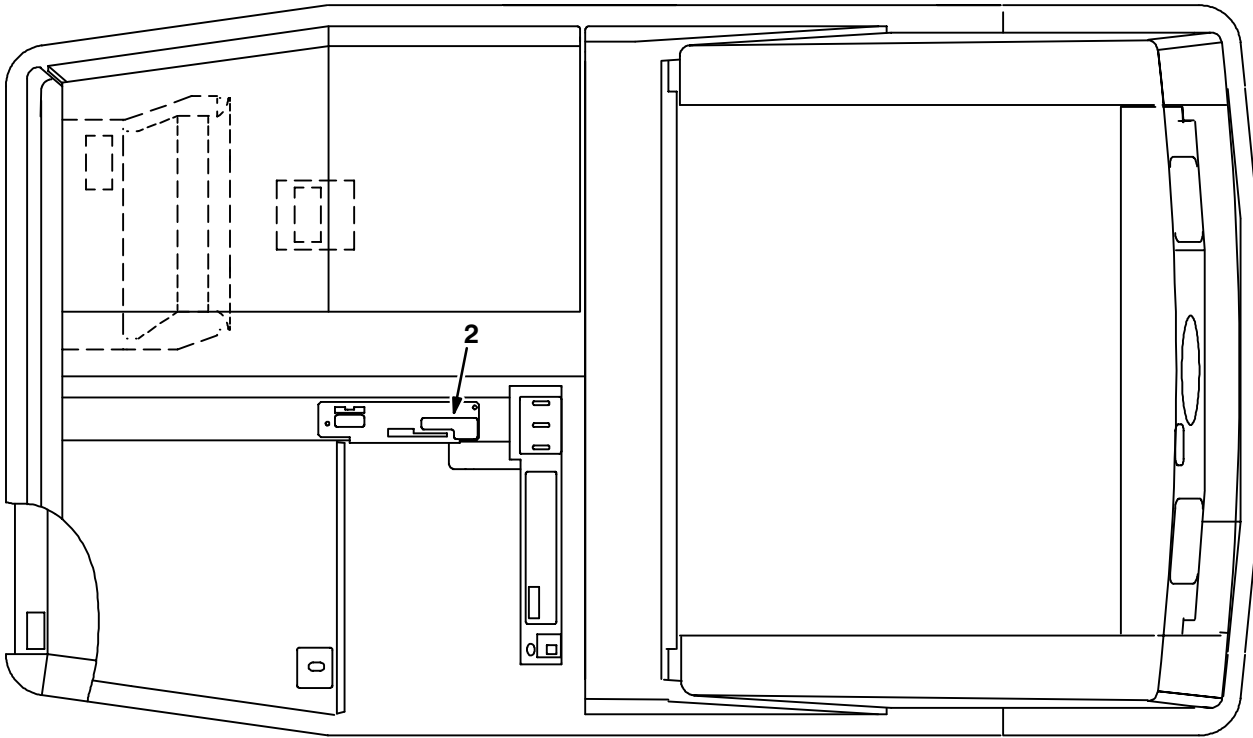

08566/08774

Ref.	Tennant Part No.	Machine Serial Number	Description	Qty.
1	59767	(000000–)	Label Set, Info & Hazard	1
2	70705	(000000–)	Label Set, Operational 800	1
3	70536	(000000–)	Label, Numerals 800	2
4	09905	(000000–)	Label, Logo, Tennant Oval	1

SECTION 3

CONTENTS

	PAGE
Fig. 1 – Flashing Light Kit, Overhead Guard	3-2
Fig. 2 – Revolving Light Kit, Overhead Guard	3-4
Fig. 3 – Flashing Light Kit, Cab	3-6
Fig. 4 – Revolving Light Kit, Cab	3-8
Fig. 5 – Flashing Light Kit, Low	3-10
Fig. 6 – Revolving Light Kit, Low	3-12
Fig. 7 – Back-Up Alarm Warning Kit	3-14
Fig. 8 – Back-Up Alarm Warning Kit, Blower Wand	3-16
Fig. 9 – Overhead Guard Kit	3-17
Fig. 10 – Blower Group	3-18
Fig. 11 – Blower Vac Fan Group	3-20
Fig. 12 – Blower Group	3-22
Fig. 13 – Blower Vac Fan Group	3-24
Fig. 14 – Hopper Floor Kit	3-26
Fig. 15 – Bumper Assembly, SE	3-27
Fig. 16 – Bumper Assembly, SE	3-28
Fig. 17 – Bumper Assembly, SE	3-29
Fig. 18 – Side Brush Lift Group, L.H.	3-30
Fig. 19 – Side Brush Lift Group, L.H.	3-32
Fig. 20 – Side Brush Group, L.H.	3-34
Fig. 21 – Side Brush Wire Harness Group, L.H.	3-36
Fig. 22 – Side Brush Wire Harness Group, L.H.	3-37
Fig. 23 – Side Brush Hydraulic Hose Group, L.H.	3-38
Fig. 24 – Side Brush Hydraulic Hose Group, L.H.	3-39
Fig. 25 – Side Brush Light Group	3-40
Fig. 26 – Cab Group	3-42
Fig. 27 – Cab Door Assembly	3-44
Fig. 28 – Cab Insulation Group	3-46
Fig. 29 – Mirror Kit	3-48
Fig. 30 – Air Cleaner Assembly, Air Conditioner	3-50
Fig. 31 – Air Conditioner Group	3-52
Fig. 32 – Heater/Pressurizer Assembly	3-54
Fig. 33 – Alternator Group, SE	3-56
Fig. 34 – Vacuum Wand Kit	3-58
Fig. 35 – Vacuum Wand Kit	3-60
Fig. 36 – Side Brush Dust Control Kit	3-62
Fig. 37 – Air Cleaner Assembly, Gas SE	3-64
Fig. 38 – Air Cleaner Assembly, LPG SE	3-66
Fig. 39 – Protectoseal Fuel Tank Cap Group	3-68
Fig. 40 – Fire Extinguisher Kit	3-69
Fig. 41 – Solid Tire and Rim Assembly, Front	3-70
Fig. 42 – Solid Tire and Rim Assembly, Rear	3-71
Fig. 43 – Seat Belt Kit	3-72
Fig. 44 – Neutral Start Group	3-73
Fig. 45 – RFS Filter System Group	3-74
Fig. 46 – Documentation Group	3-76

Fig. 1 – Flashing Light Kit, Overhead Guard

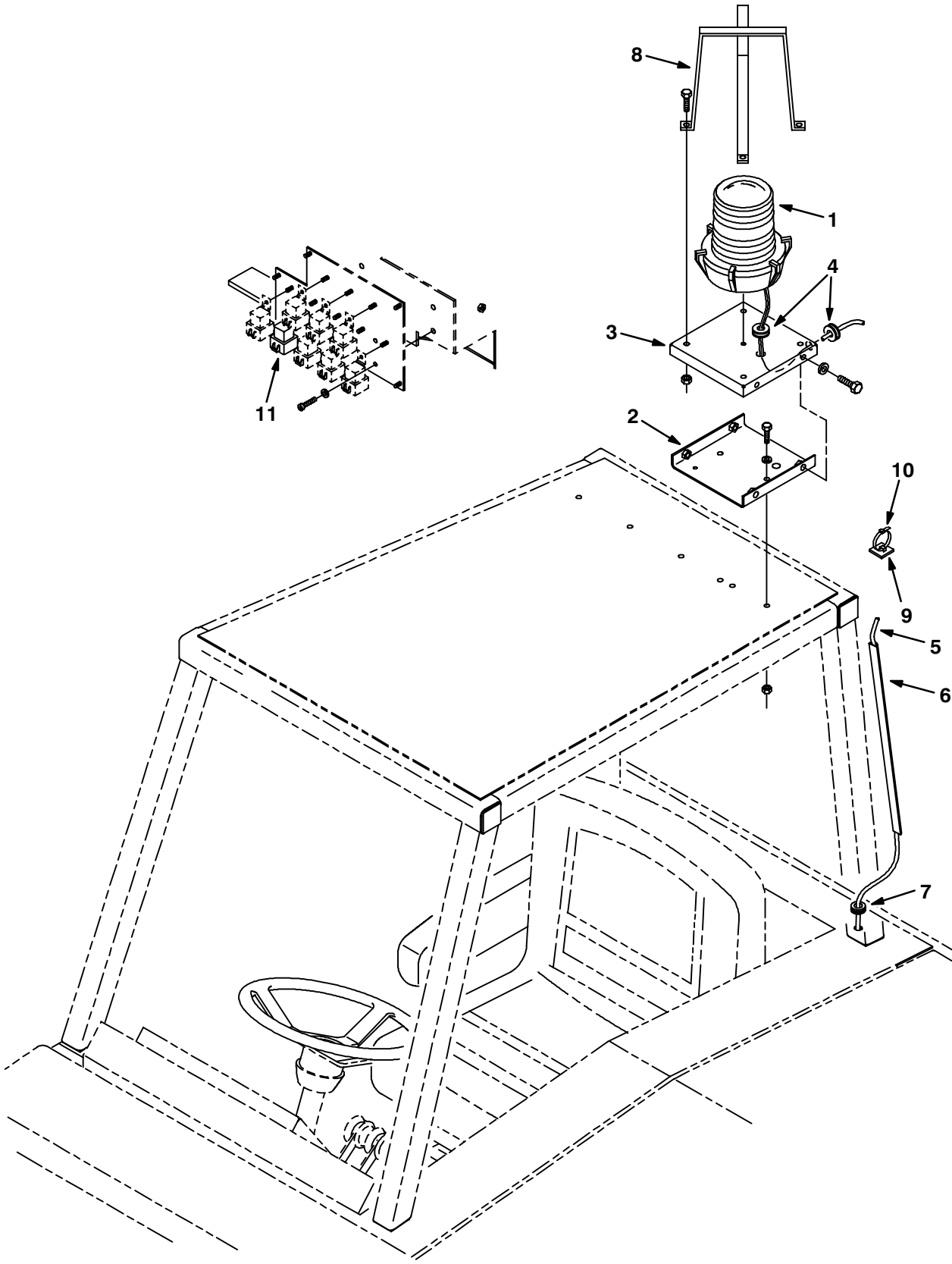

Fig. 1 – Flashing Light Kit, Overhead Guard

Ref.	Tennant Part No.	Machine Serial Number	Description	Qty.
▽	73755	(000000–) Light Kit Flsh 800L Ohg	1
▽ 1	82063	(000000–) Light, Flashing, Amber, 12V–Re	1
	58520	(000000–) Lens,Flashing Lite Fr207 Amber	1
	45779	(000000–) Bulb, 12V	1
2	73899	(000000–) Bracket	1
3	73898	(000000–) Panel	1
4	10632–20	(000000–) Grommet,Rbr,0.38ld,For .06Matl	2
5	74000	(000000–) Harness,Rev/Flsh Light,Cab,Ohg	1
6	86331	(000000–) Duct, Vinyl .40X .75X26.0 .25D	1
7	10632–2	(000000–) Grommet,Rbr,0.63ld,For .13Matl	1
8	45272	(000000–) Guard Wldt, Lights, Revl & Flsh	1
9	55248	(000000–) Cable Tie Mount	3
10	49266	(000000–) Tie, Cable	3
11	56186	(000000–) Relay, Shrouded, 12V	1
	58518	(000000–) Lens,Flashing Lite Fr207 Red	1
	58519	(000000–) Lens,Flashing Lite Fr207 Blue	1

Fig. 2 – Revolving Light Kit, Overhead Guard

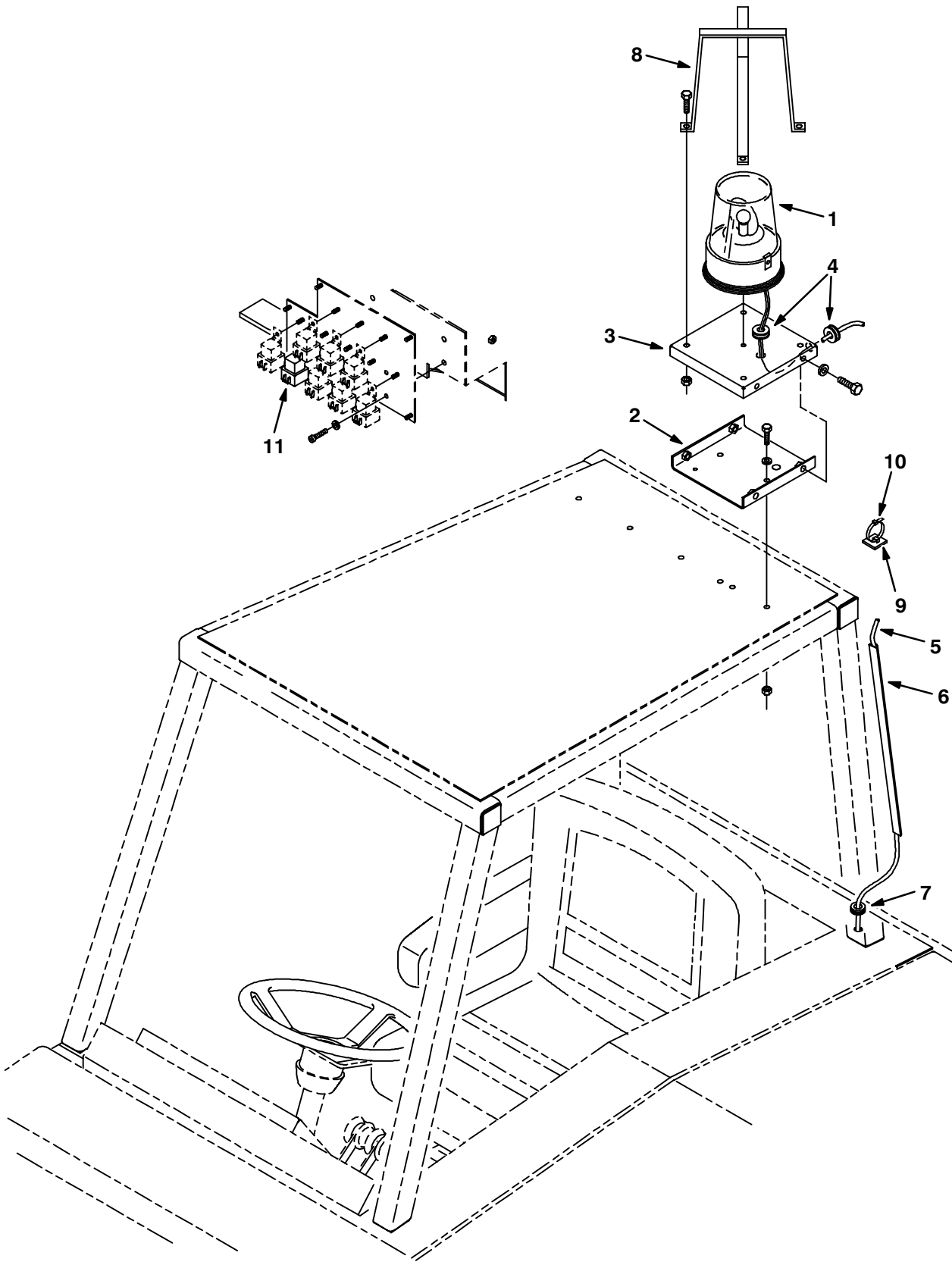

Fig. 2 – Revolving Light Kit, Overhead Guard

Ref.	Tennant Part No.	Machine Serial Number	Description	Qty.
▽	73757	(000000–) Light Kit Revl 800L Ohg	1
▽ 1	82200	(000000–) Light,Rev.Amber 12V–Reworked	1
	44681–1	(000000–) Lens,Rev.Light,Amber	1
	45779	(000000–) Bulb, 12V	1
2	73899	(000000–) Bracket	1
3	73898	(000000–) Panel	1
4	10632–20	(000000–) Grommet,Rbr,0.38ld,For .06Matl	2
5	74000	(000000–) Harness,Rev/Flsh Light,Cab,Ohg	1
6	86331	(000000–) Duct, Vinyl .40X .75X26.0 .25D	1
7	10632–2	(000000–) Grommet,Rbr,0.63ld,For .13Matl	1
8	45272	(000000–) Guard Wldt, Lights, Revl & Flsh	1
9	55248	(000000–) Cable Tie Mount	3
10	49266	(000000–) Tie, Cable	3
11	56186	(000000–) Relay, Shrouded, 12V	1
	44681	(000000–) Lens,Rev.Light,Red	1
	44681–2	(000000–) Lens,Rev.Light,Blue	1

Fig. 3 – Flashing Light Kit, Cab

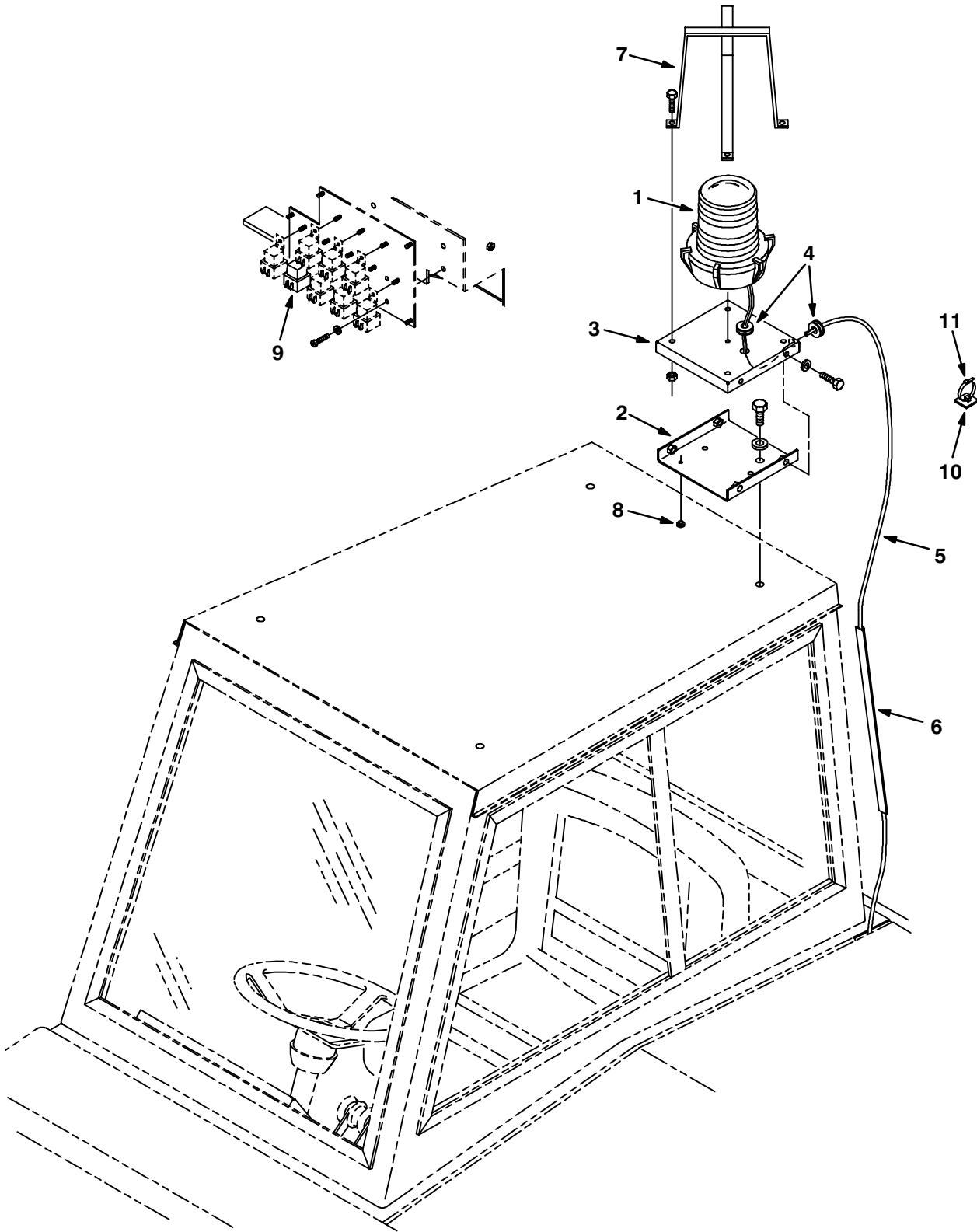

Fig. 3 – Flashing Light Kit, Cab

Ref.	Tenant Part No.	Machine Serial Number	Description	Qty.
▽	73751	(000000–)	Light Kit Flsh 800L Cab	1
▽ 1	82063	(000000–)	Light, Flashing, Amber, 12V–Re	1
	58520	(000000–)	Lens,Flashing Lite Fr207 Amber	1
	45779	(000000–)	Bulb, 12V	1
2	73899	(000000–)	Bracket	1
3	73898	(000000–)	Panel	1
4	10632–20	(000000–)	Grommet,Rbr,0.38ld,For .06Matl	2
5	74000	(000000–)	Harness,Rev/Flsh Light,Cab,Ohg	1
6	86331	(000000–)	Duct, Vinyl .40X .75X26.0 .25D	1
7	45272	(000000–)	Guard Wldt, Lights, Revl & Flsh	1
8	29233	(000000–)	Bumper, Rubber	1
9	56186	(000000–)	Relay, Shrouded, 12V	1
10	55248	(000000–)	Cable Tie Mount	3
11	49266	(000000–)	Tie, Cable	3
	58518	(000000–)	Lens,Flashing Lite Fr207 Red	1
	58519	(000000–)	Lens,Flashing Lite Fr207 Blue	1

Fig. 4 – Revolving Light Kit, Cab

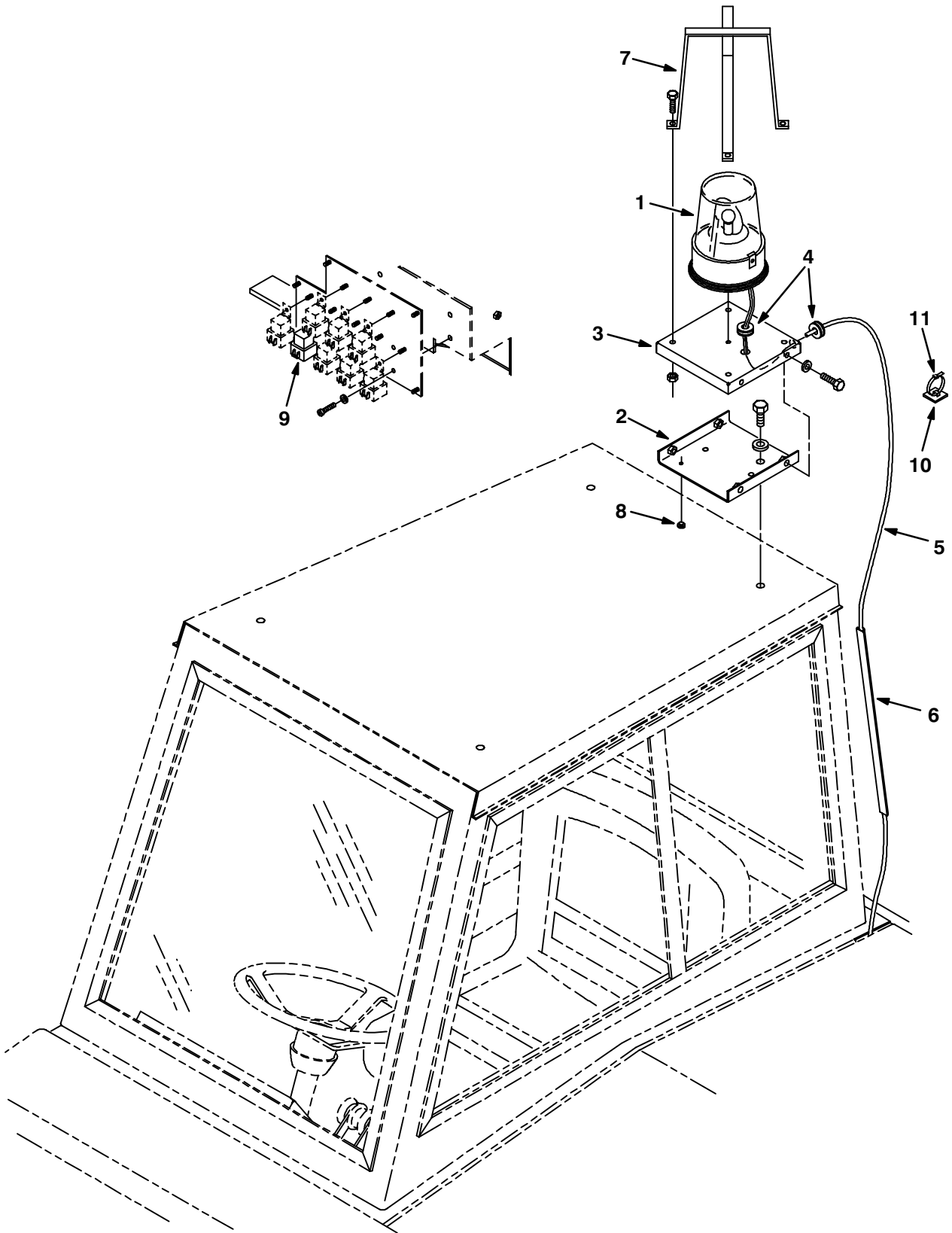

Fig. 4 – Revolving Light Kit, Cab

Ref.	Tennant Part No.	Machine Serial Number	Description	Qty.
▽	73753	(000000–) Light Kit Revl 800L Cab	1
▽ 1	82200	(000000–) Light,Rev.Amber 12V–Reworked	1
	44681–1	(000000–) Lens,Rev.Light,Amber	1
	45779	(000000–) Bulb, 12V	1
2	73899	(000000–) Bracket	1
3	73898	(000000–) Panel	1
4	10632–20	(000000–) Grommet,Rbr,0.38Id,For .06Matl	2
5	74000	(000000–) Harness,Rev/Flsh Light,Cab,Ohg	1
6	86331	(000000–) Duct, Vinyl .40X .75X26.0 .25D	1
7	45272	(000000–) Guard Wldt, Lights, Revl & Flsh	1
8	29233	(000000–) Bumper, Rubber	1
9	56186	(000000–) Relay, Shrouded, 12V	1
10	55248	(000000–) Cable Tie Mount	3
11	49266	(000000–) Tie, Cable	3
	44681	(000000–) Lens,Rev.Light,Red	1
	44681–2	(000000–) Lens,Rev.Light,Blue	1

Fig. 5 – Flashing Light Kit, Low

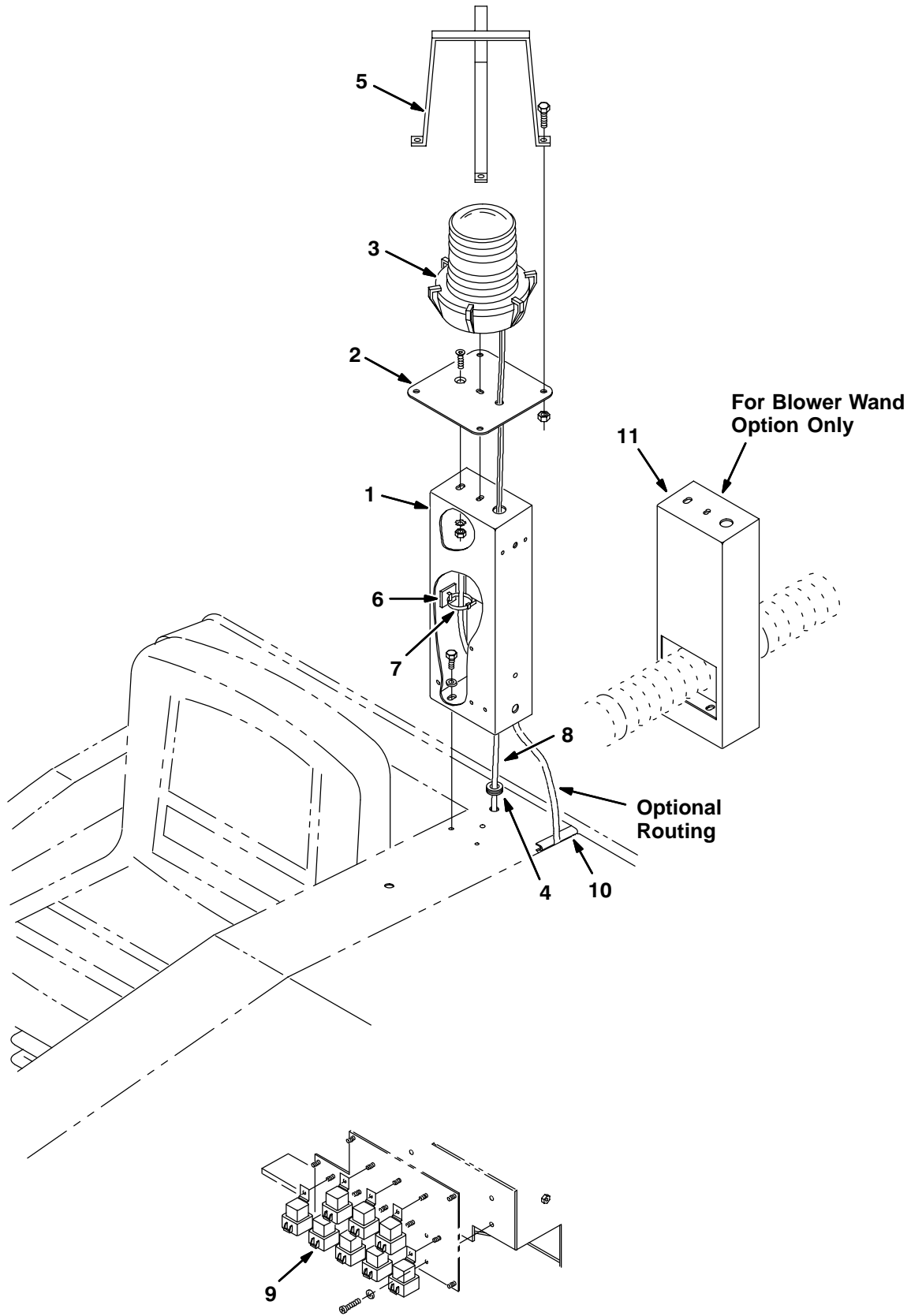

Fig. 5 – Flashing Light Kit, Low

Ref.	Tennant Part No.	Machine Serial Number	Description	Qty.
∇	73759	(000000–) Light Kit Flashing	1
1	76404	(000000–) Channel,	1
2	75573	(000000–) Plate	1
∇	82063	(000000–) Light, Flashing, Amber, 12V–Re	1
	58520	(000000–) Lens,Flashing Lite Fr207 Amber	1
	45779	(000000–) Bulb, 12V .2A 32Cp #1156	1
4	10632–11	(000000–) Grommet,Rbr,0.38Id,For .19Matl	1
5	45272	(000000–) Guard Wldt, Lights, Revl&Flsh	1
6	55248	(000000–) Cabletie Mount, Adhesive	1
7	49266	(000000–) Tie, Cable 1.75D Max 7.50Lg	1
8	74000	(000000–) Harness, Rev/Flash Light,Cab O	1
9	56186	(000000–) Relay, Shrouded, 12 Vdc	1
10	62595–18	(000000–) Molding, Trim 11–14Ga 3.00	1
11	79513	(000000–) Channel Wldt, Blower Wand	1
	58518	(000000–) Lens,Flashing Lite Fr207 Red	1
	58519	(000000–) Lens,Flashing Lite Fr207 Blue	1

Fig. 6 – Revolving Light Kit, Low

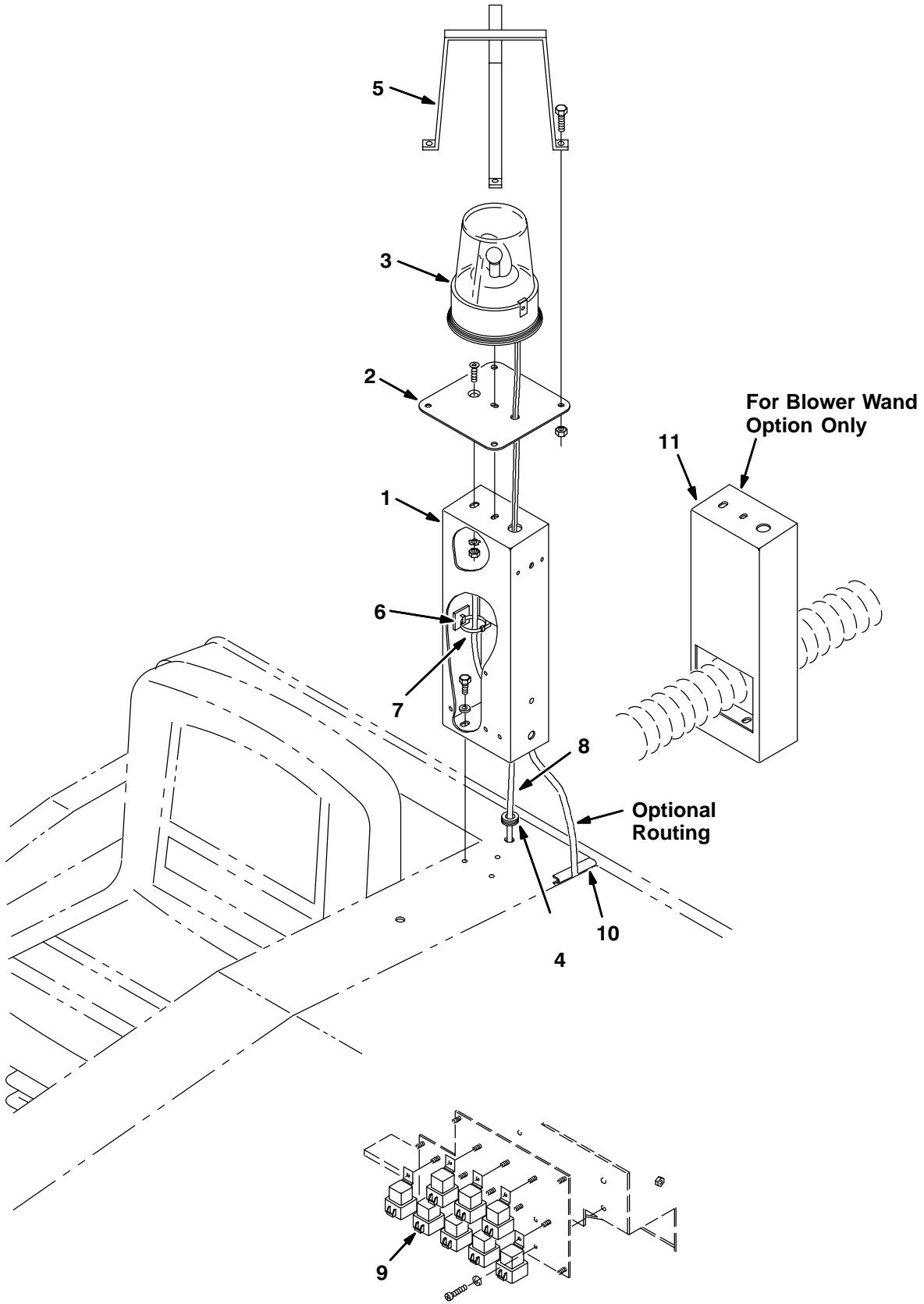

Fig. 6 – Revolving Light Kit, Low

Ref.	Tennant Part No.	Machine Serial Number	Description	Qty.
∇	73761	(000000–) Light Kit Revl 800 Low	1
1	76404	(000000–) Channel,	1
2	75573	(000000–) Plate	1
∇	82200	(000000–) Light,Rev.Amber 12V	1
	44681–1	(000000–) Lens,Rev.Light,Amber	1
	45779	(000000–) Bulb, 12V .2A 32Cp #1156	1
4	10632–11	(000000–) Grommet,Rbr,0.38Id,For .19Matl	1
5	45272	(000000–) Guard Wldt, Lights, Revl&Flsh	1
6	55248	(000000–) Cabletie Mount, Adhesive	1
7	49266	(000000–) Tie, Cable 1.75D Max 7.50Lg	1
8	74000	(000000–) Harness, Rev/Flash Light,Cab O	1
9	56186	(000000–) Relay, Shrouded, 12 Vdc	1
10	62595–18	(000000–) Molding, Trim 11–14Ga 3.00	1
11	79513	(000000–) Channel Wldt, Blower Wand	1
	44681	(000000–) Lens,Rev.Light,Red	1
	44681–2	(000000–) Lens,Rev.Light,Blue	1

Fig. 7 – Back-Up Alarm Warning Kit

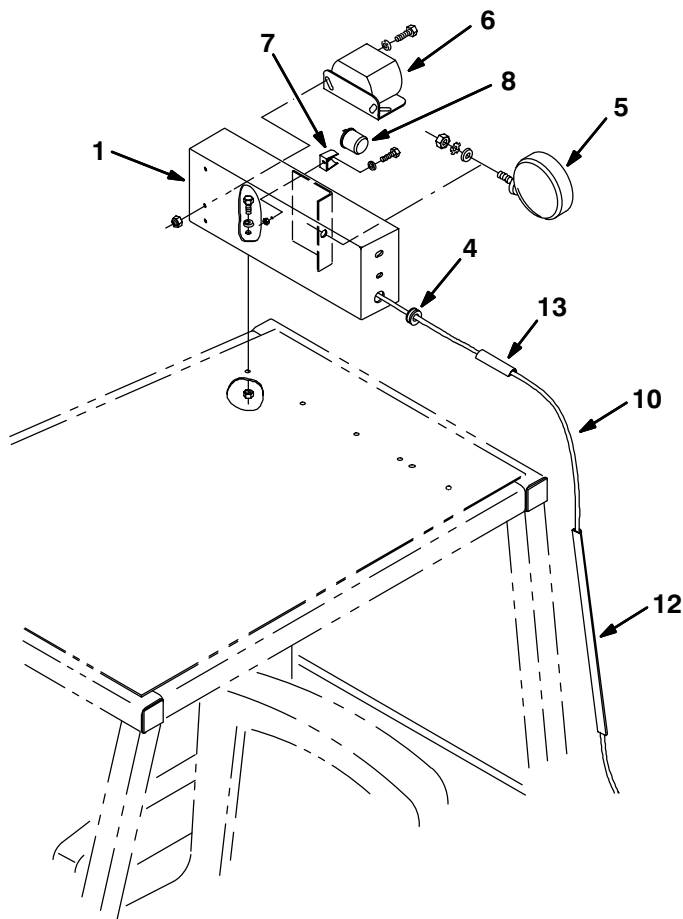
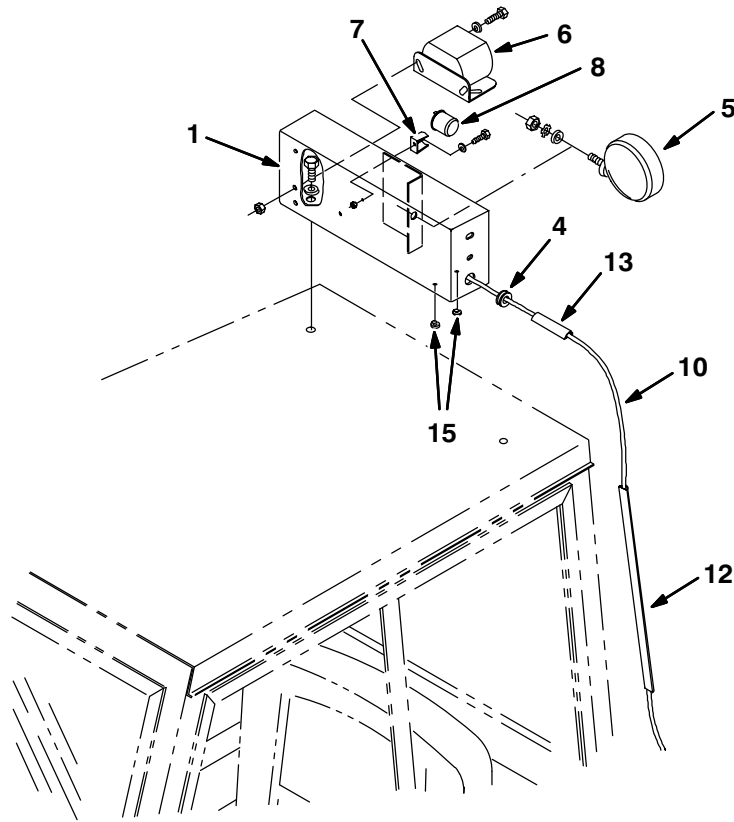
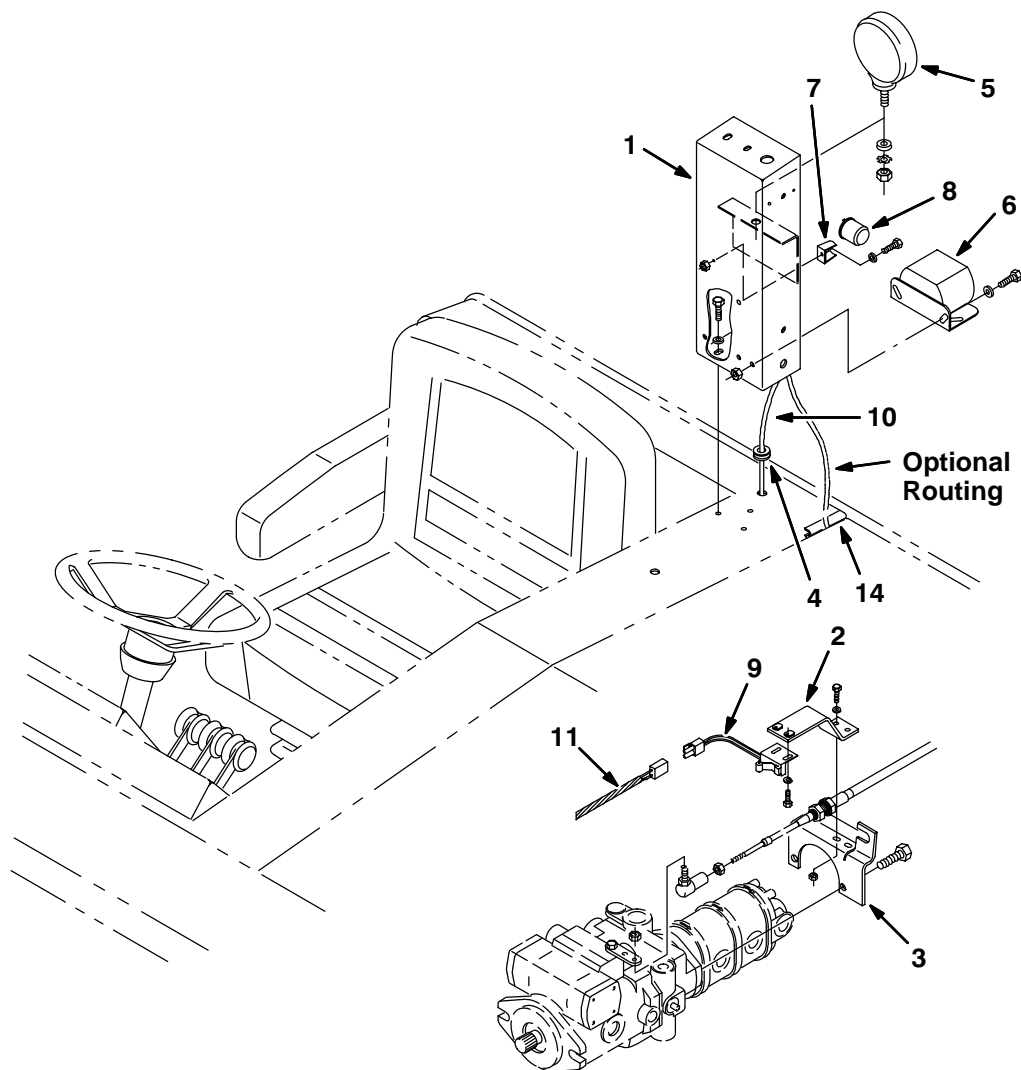

Fig. 7 – Back-Up Alarm Warning Kit



08758/08759

Ref.	Tennant Part No.	Machine Serial Number	Description	Qty.	
▽	70696	(000000–) Warning Kit, Backup	1	
1	76404	(000000–) Channel,	1	
2	75568	(000000–) Bracket	1	
3	76427	(000000–) Bracket, Mounting, Alarm Switch	1	
4	10632–9	(000000–) Grommet, Rbr, 0.56ld, For .13Matl	1	
▽	5	36438	(000000–) Headlight Assy, 210G	1
		36439	(000000–) Bulb, 12V .9A	1
6	61920	(000000–) Horn, Back-Up Alarm	1	
7	24576–1	(000000–) Bracket, Flasher	1	
8	24576	(000000–) Flasher, 12V. Ideal Co. Hd552Ps83	1	
9	59965	(000000–) Switch, Roller	1	
10	76415	(000000–) Harness, Alarm, Backup	1	
11	76460	(000000–) Harness, Jumper, Backup	1	
12	77423	(000000–) Duct, Vinyl 26.0"	1	
13	86333	(000000–) Duct, Vinyl .40X.75X3.5 .25D	1	
14	62595–18	(000000–) Molding, Trim 11–14Ga 3.00	1	
15	29233	(000000–) Bumper, 3/32 Matl.	1	

Fig. 8 – Back-Up Alarm Warning Kit, Blower Wand

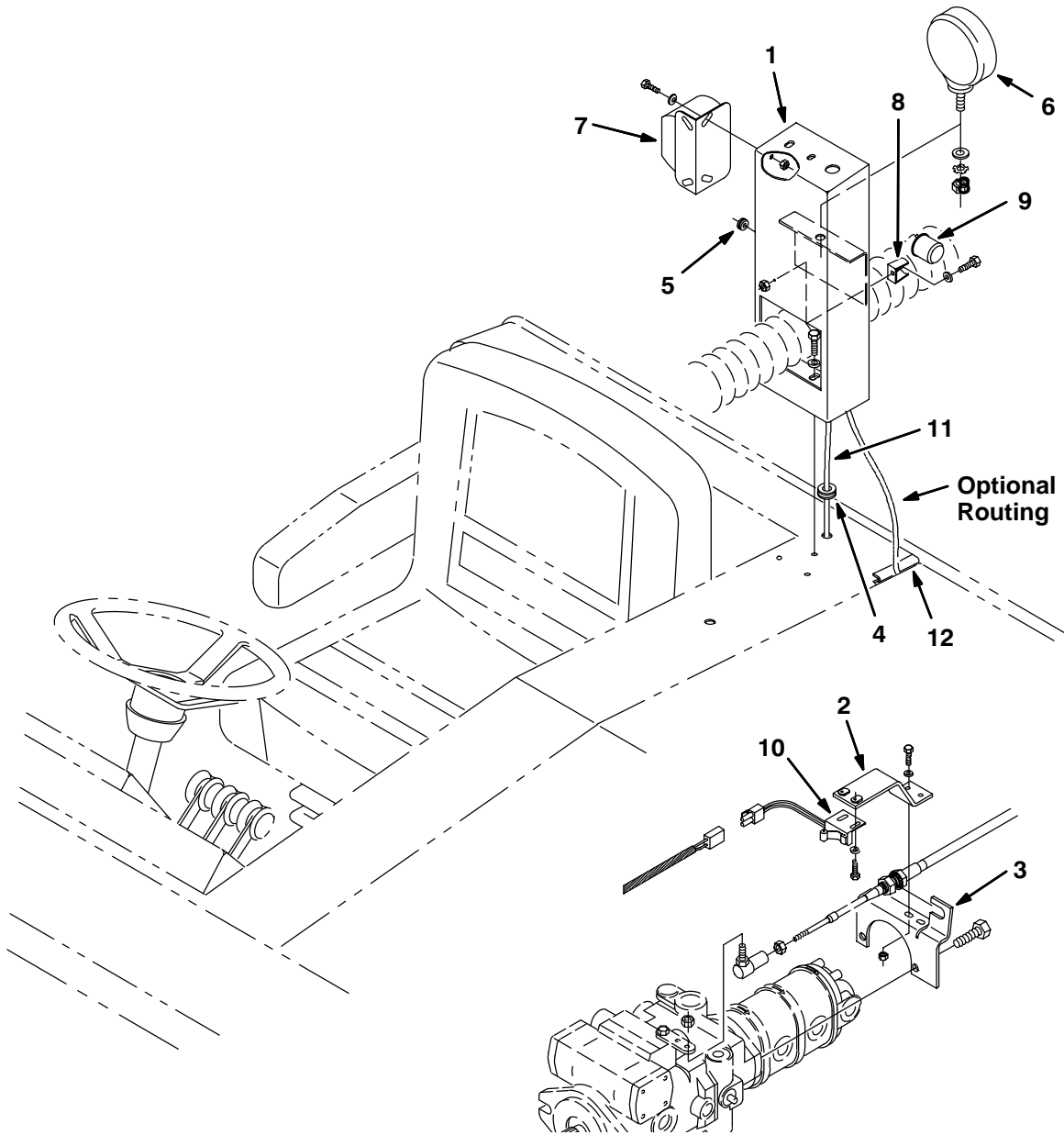

Fig. 8 – Back-Up Alarm Warning Kit, Blower Wand

Ref.	Tenant Part No.	Machine Serial Number	Description	Qty.
∇	79554	(000000–) Warning Kit, Backup Low Blower	1
1	79513	(000000–) Channel Wldt, Blower Wand	1
2	75568	(000000–) Bracket	1
3	76427	(000000–) Bracket, Mounting,Alarm Switch	1
4	10632–9	(000000–) Grommet,Rbr,0.56ld,For .13Matl	1
5	10632–5	(000000–) Grommet Rbr 0.25ld For .09Matl	1
∇	6	36438	(000000–) Headlight Assy,210G	1
		36439	(000000–) Bulb, 12V .9A	1
7	61920	(000000–) Horn, Back-Up Alarm	1
8	24576–1	(000000–) Bracket, Flasher	1
9	24576	(000000–) Flasher,12V.Ideal Co.Hd552Ps83	1
10	59965	(000000–) Switch, Roller	1
11	76415	(000000–) Harness, Alarm, Backup	1
12	62595–18	(000000–) Molding, Trim 11–14Ga 3.00	1

Fig. 9 – Overhead Guard Kit

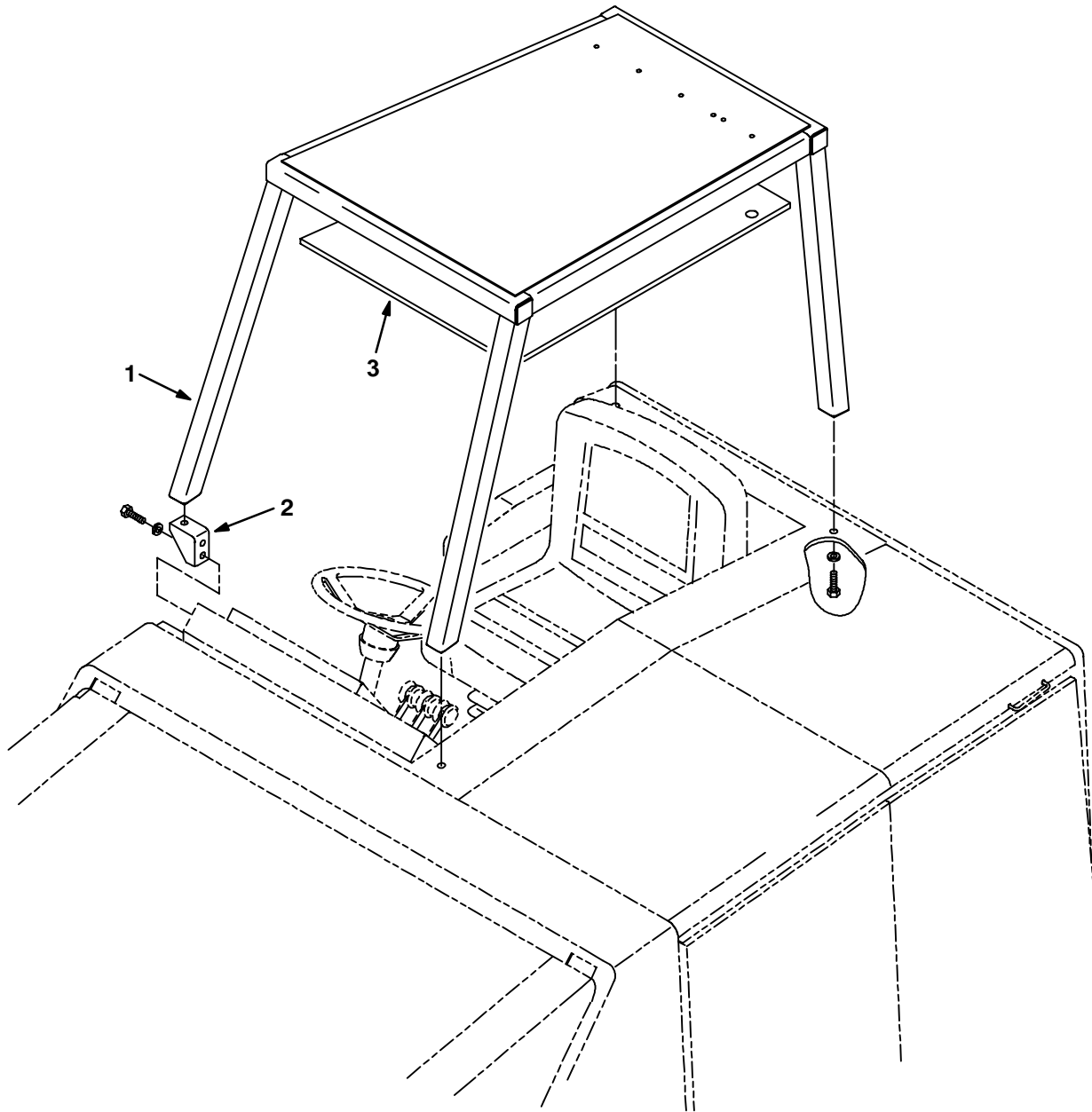

Fig. 9 – Overhead Guard Kit

Ref.	Tennant Part No.	Machine Serial Number	Description	Qty.
∇	70669	(000000–) Guard Kit, Overhead	1
1	65258	(000000–) Guard Wldt, Overhead	1
2	70454	(000000–) Bracket, Mtg, Ohg	1
3	74007	(000000–) Foam, Insulation	1

Fig. 10 – Blower Group

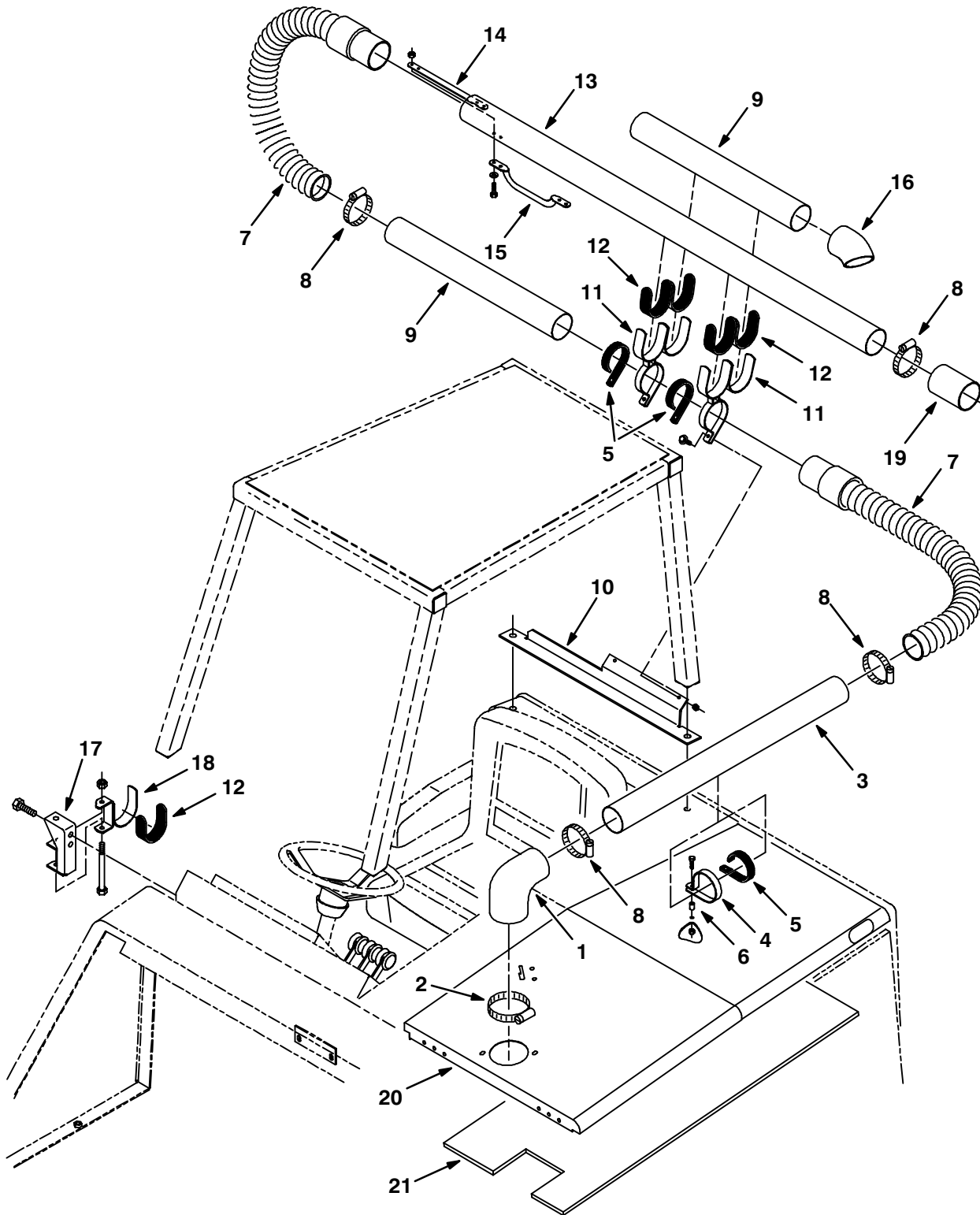

Fig. 10 – Blower Group

Ref.	Tennant Part No.	Machine Serial Number	Description	Qty.
1	59919	(000000-xxxxxx)	Hose, Reducer	1
2	23498	(000000-xxxxxx)	Clamp-Wormdrive, 2.63- 4.50D	1
3	73692	(000000-xxxxxx)	Tube, Blower Wand	1
4	77631	(000000-xxxxxx)	Clamp, 3.250 Id	1
5	71025	(000000-xxxxxx)	Pad, Rubber	3
6	73675	(000000-xxxxxx)	Spacer	1
7	64320	(000000-xxxxxx)	Hose& Cuff Assy,Vinyl3.0ldx 24	2
8	43555	(000000-xxxxxx)	Clamp-Wormdrive, 1.62- 3.50D	4
9	73700	(000000-xxxxxx)	Tube, Blower Wand	2
10	73689	(000000-xxxxxx)	Bracket, Hose, Blower	1
11	76578	(000000-xxxxxx)	Clamp Wldt, Tube, Blower Wand	2
12	69981	(000000-xxxxxx)	Pad, Rubber	5
13	77743	(000000-001118)	Blower Tube Replacement Kit	1
14	69937	(000000-xxxxxx)	Plate, Backing, Handle	1
15	32822	(000000-xxxxxx)	Handle, Grab	1
16	73677	(000000-xxxxxx)	Hose, Rubber	1
17	73653	(000000-xxxxxx)	Bracket Wldt	1
18	69918	(000000-xxxxxx)	Bracket, Support, Blower	1
19	76575	(000000-xxxxxx)	Hose, Rubber	1
20	79012	(000000-xxxxxx)	Cover Wldt, Engine	1
21	73709	(000000-xxxxxx)	Bracket, Channel	1

NOTE: Blower Kit, TENNANT Part Number 73776, includes Fig. 10, and Fig. 11.

Fig. 11 – Blower Vac Fan Group

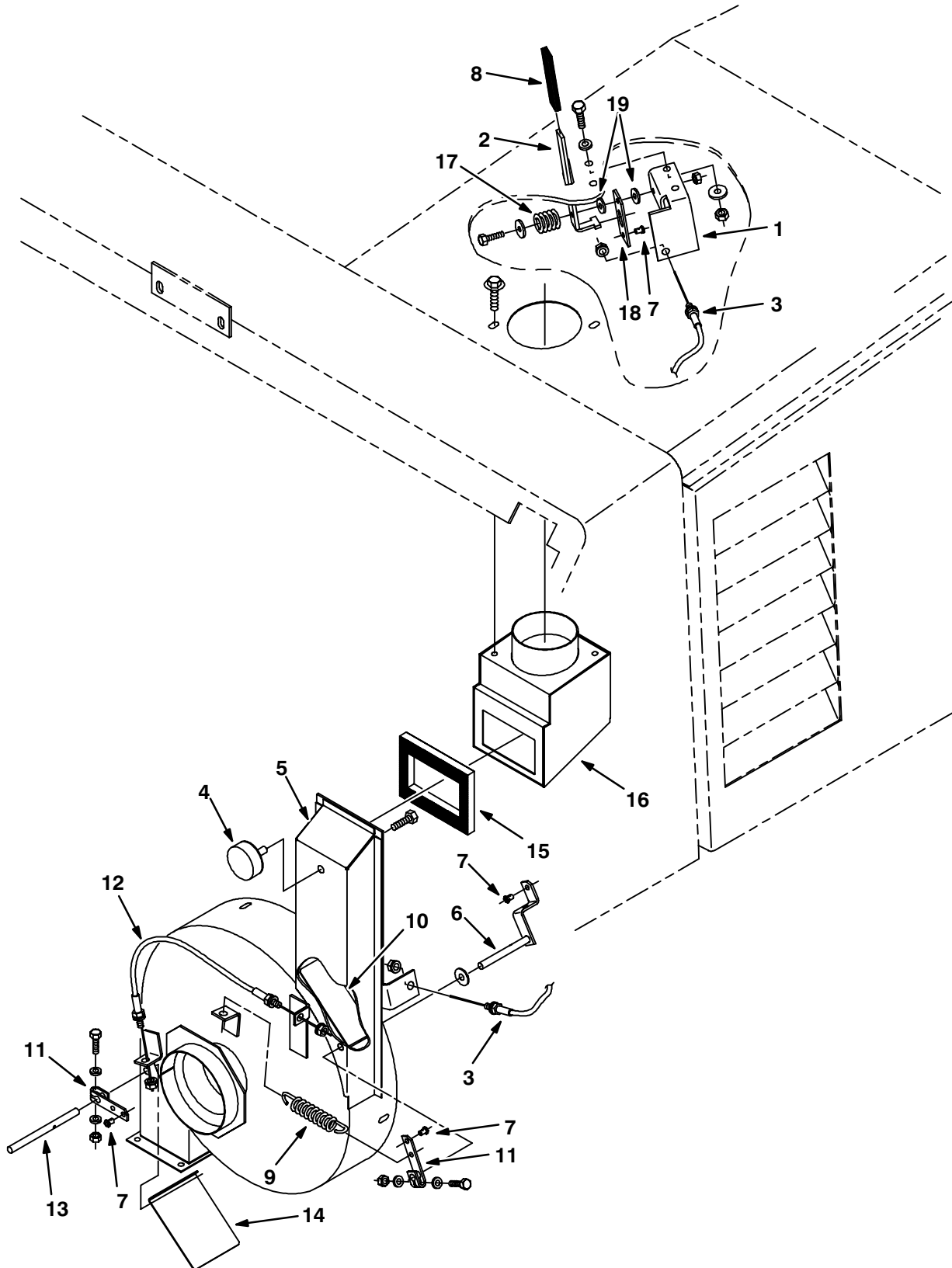

Fig. 11 – Blower Vac Fan Group

Ref.	Tennant Part No.	Machine Serial Number	Description	Qty.
1	70870	(000000-xxxxxx)	Bracket, Mounting, Lever	1
2	70871	(000000-xxxxxx)	Lever, Blower	1
3	70879	(000000-xxxxxx)	Cable Assy	1
4	70756	(000000-xxxxxx)	Bumper, Rubber	1
5	73656	(000000-xxxxxx)	Housing Wldt, Vac Fan, Front	1
6	73671	(000000-xxxxxx)	Arm, Wldt, Outlet	1
7	43242	(000000-xxxxxx)	Swivel	4
8	87246	(000000-xxxxxx)	Grip Vinyl .18 X .75 X 4.00	1
9	01274	(000000-xxxxxx)	Sprng,Tens,0.965Odx.09Wire4.4L	1
10	73661	(000000-xxxxxx)	Plate, Damper, Outlet	1
11	73663	(000000-xxxxxx)	Arm, Couple	1
12	70878	(000000-xxxxxx)	Cable Assy	1
13	73660	(000000-xxxxxx)	Rod, Inlet	1
14	73664	(000000-xxxxxx)	Plate, Damper, Inlet	1
15	73655	(000000-xxxxxx)	Insulation, Acoustic, Fan	1
16	73674	(000000-xxxxxx)	Duct, Wldt	1
17	44853	(000000-xxxxxx)	Sprng,Comp,0.74Idx.11Wire 1.5L	1
18	76448	(000000-xxxxxx)	Plate, Lever	1
19	16236	(000000-xxxxxx)	Washer,Nyl,0.26 Bx0.72 X.07 Th	2

NOTE: Blower Kit, TENNANT Part Number 73776, includes Fig. 10, and Fig. 11.

Fig. 12 – Blower Group

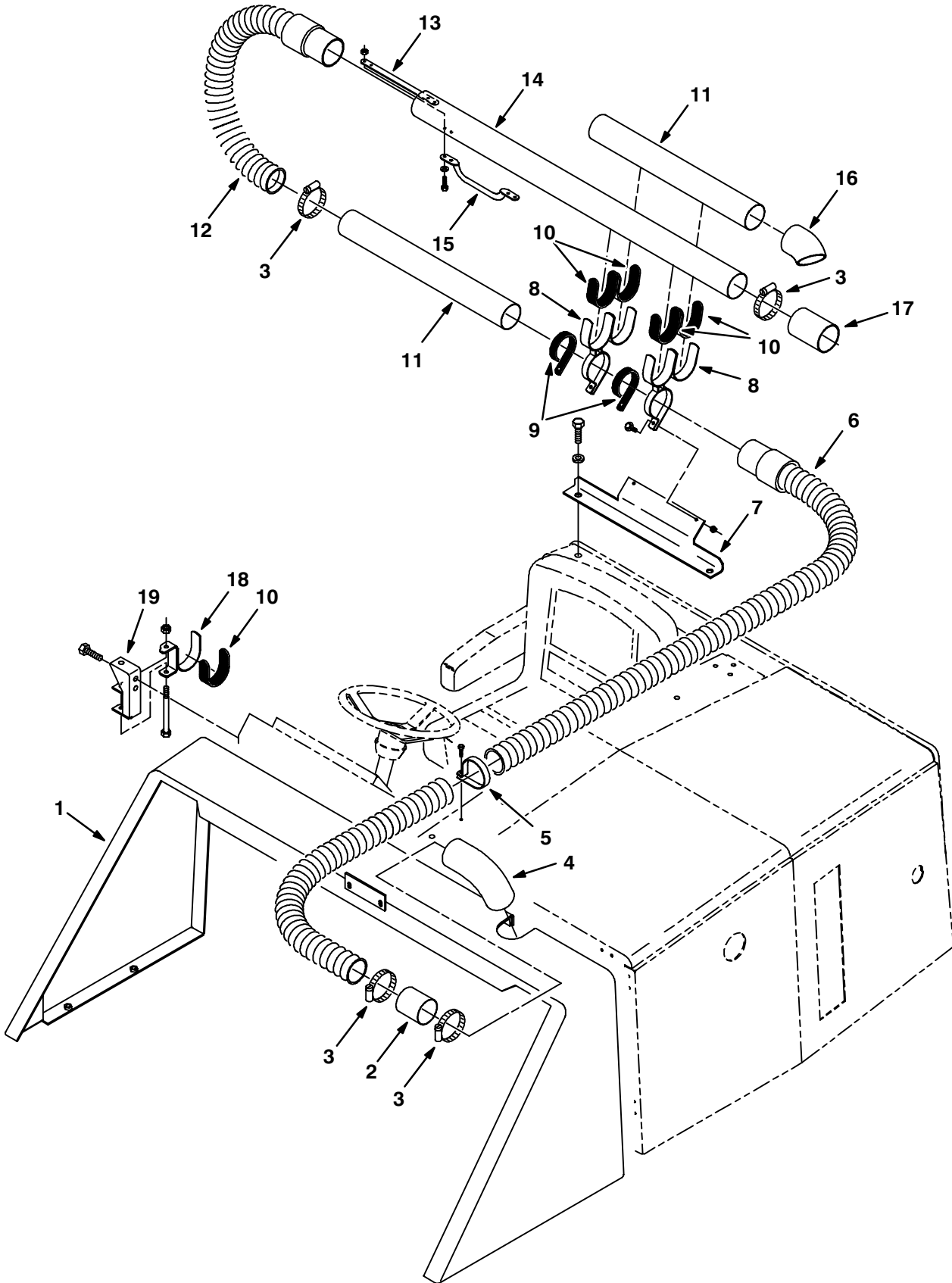

Fig. 12 – Blower Group

Ref.	Tenant Part No.	Machine Serial Number	Description	Qty.
1	77665	(xxxxxx-) Panel, Lintel	1
2	76945	(xxxxxx-) Tube, 3.00D 2.88B 3.00,Stl Dom	1
3	43555	(xxxxxx-) Clamp-Wormdrive, 1.62- 3.50D	4
4	75689	(xxxxxx-) Hose, Rubber, Elbow, 3.00	1
5	77631	(xxxxxx-) Clamp, 3.250 Id	1
6	79650	(xxxxxx-) Hose& Cuff Assy	1
7	73689	(xxxxxx-) Bracket, Hose, Blower	1
8	76578	(xxxxxx-) Clamp Wldt, Tube, Blower Wand	2
9	71025	(xxxxxx-) Pad, Rubber	2
10	69981	(xxxxxx-) Pad, Rubber	5
11	73700	(xxxxxx-) Tube, Blower Wand	2
12	64320	(xxxxxx-) Hose& Cuff Assy,Vinyl3.0ldx 24	1
13	69937	(xxxxxx-) Plate, Backing, Handle	1
14	77742	(001119-) Tube, Blower Wand	1
15	32822	(xxxxxx-) Handle, Grab	1
16	73677	(xxxxxx-) Hose, Rubber	1
17	76575	(xxxxxx-) Hose, Rubber	1
18	69918	(xxxxxx-) Bracket, Support, Blower	1
19	73653	(xxxxxx-) Bracket Wldt	1

Fig. 13 – Blower Vac Fan Group

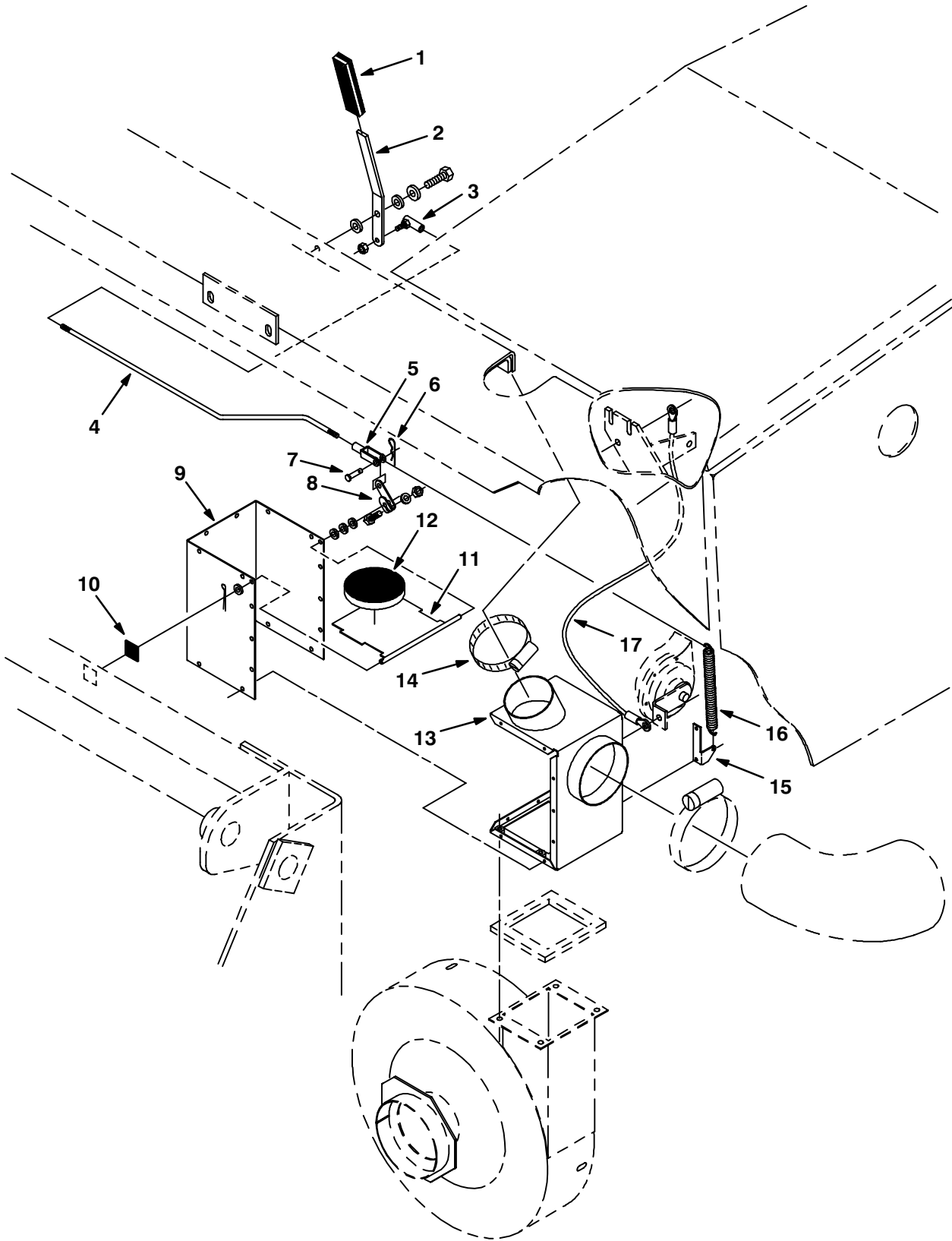
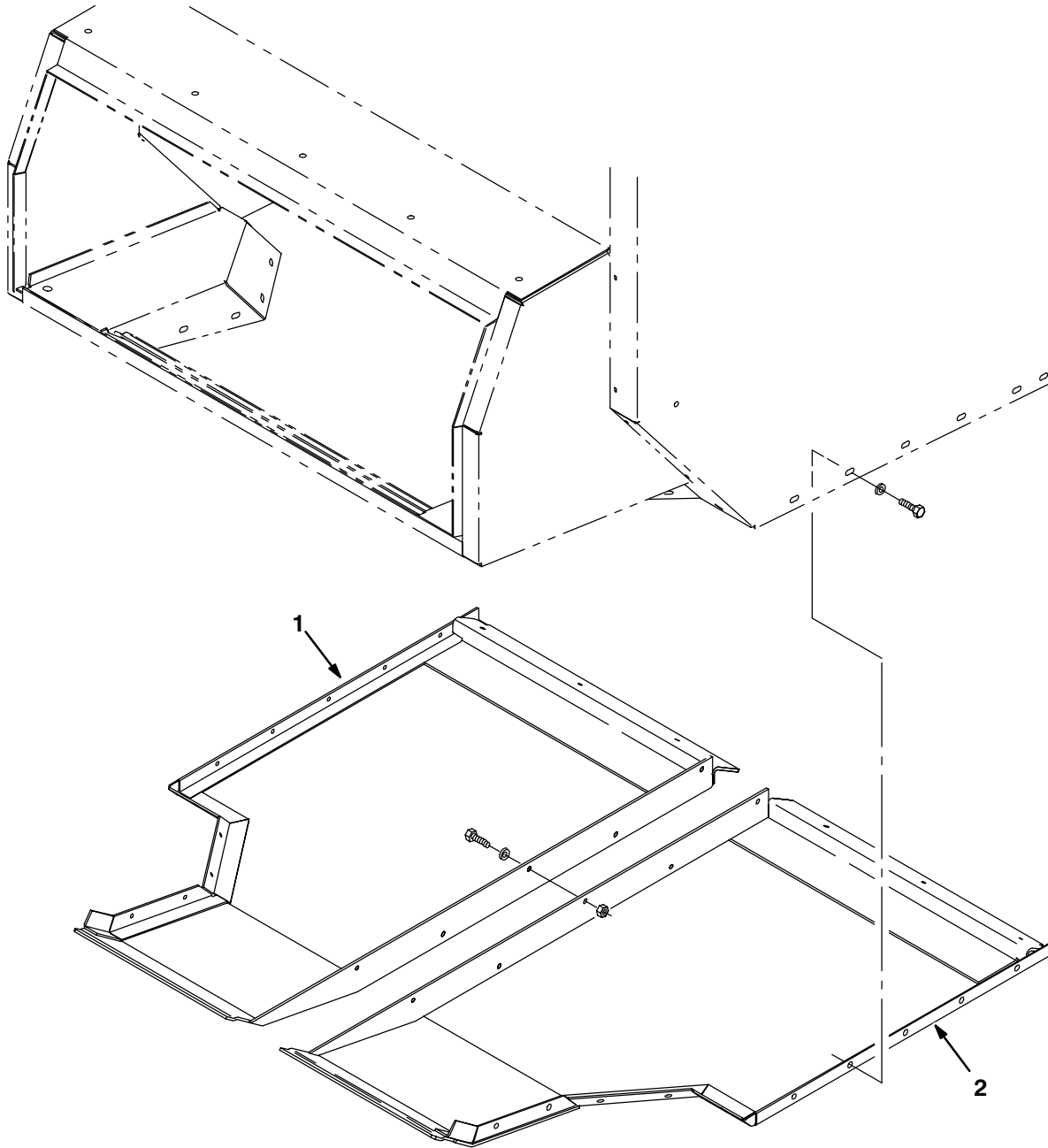

Fig. 13 – Blower Vac Fan Group

Ref.	Tenant Part No.	Machine Serial Number	Description	Qty.
1	87246	(xxxxxx-) Grip Vinyl .18 X .75 X 4.00	1
2	77662	(xxxxxx-) Lever	1
3	14601	(xxxxxx-) Ball Joint, 250-28	1
4	77629	(xxxxxx-) Rod, Push	1
5	14595-1	(xxxxxx-) Clevis, Adjust. 0.25-28Th. Cad.	1
6	08085	(xxxxxx-) Pin Hair Cotter .056Dx1.1L	1
7	14605	(xxxxxx-) Pin, Clevis, 0.25 Dia. X 0.75 Lg	1
8	30480	(xxxxxx-) Lever Carburator	1
9	77538	(xxxxxx-) Panel, Vac Duct	1
10	21170	(xxxxxx-) Pad	1
11	77537	(xxxxxx-) Panel, Flap Valve	1
12	77671	(xxxxxx-) Insulation, S/Foam	1
13	77542	(xxxxxx-) Panel, Vac Duct	1
14	43555	(xxxxxx-) Clamp-Wormdrive, 1.62- 3.50D	1
15	77670	(xxxxxx-) Bracket	1
16	29260	(xxxxxx-) Sprng, Tens, 0.37Odx.05Wire 4.5L	1
17	82731	(xxxxxx-) Wire-Ground, Alternator	1

Fig. 14 – Hopper Floor Kit



07667/07668

Ref.	Tennant Part No.	Machine Serial Number	Description	Qty.
∇	70686	(000000–) Hopper Floor Kit, St Stl 800	1
1	77611	(000000–) Panel Wldt, Hopper, Floor, RH	1
2	77613	(000000–) Panel Wldt, Hopper, Floor, LH	1

Fig. 15 – Bumper Assembly, SE

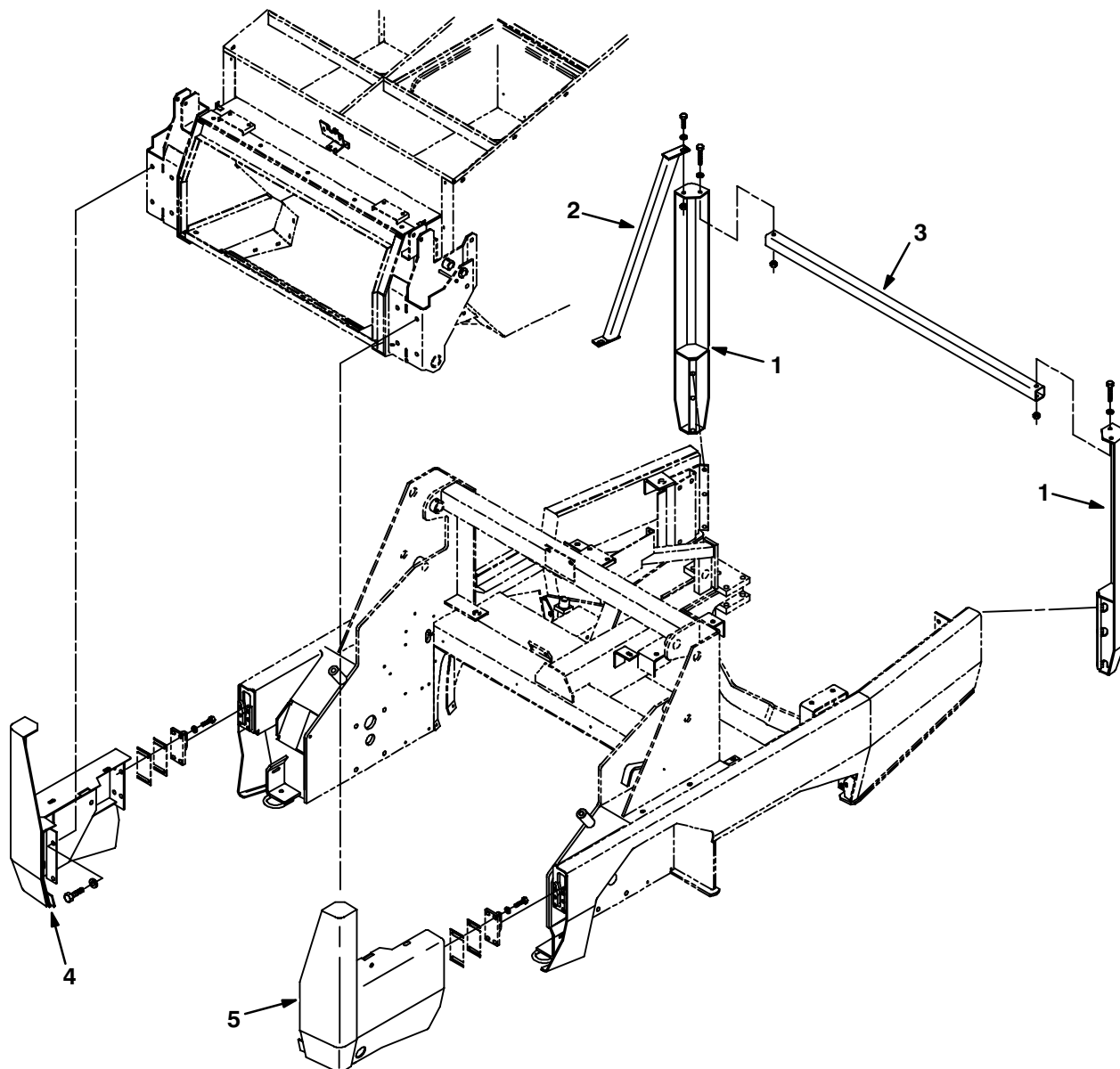

07683/07684

Ref.	Tennant Part No.	Machine Serial Number	Description	Qty.
▽	70684	(000000-001184)	Bumper Assy, Se	1
1	70802	(000000-001184)	Leg Wldt, Bumper, Se	2
2	70793	(000000-001184)	Brace Wldt, Bumper, Se	1
3	70815	(000000-001184)	Tube, Cross, Bumper, Se	1
4	70885	(000000-001184)	Leg Wldt, Bumper, Se	1
5	73688	(000000-001184)	Leg Wldt, Bumper, Se	1

Fig. 16 – Bumper Assembly, SE

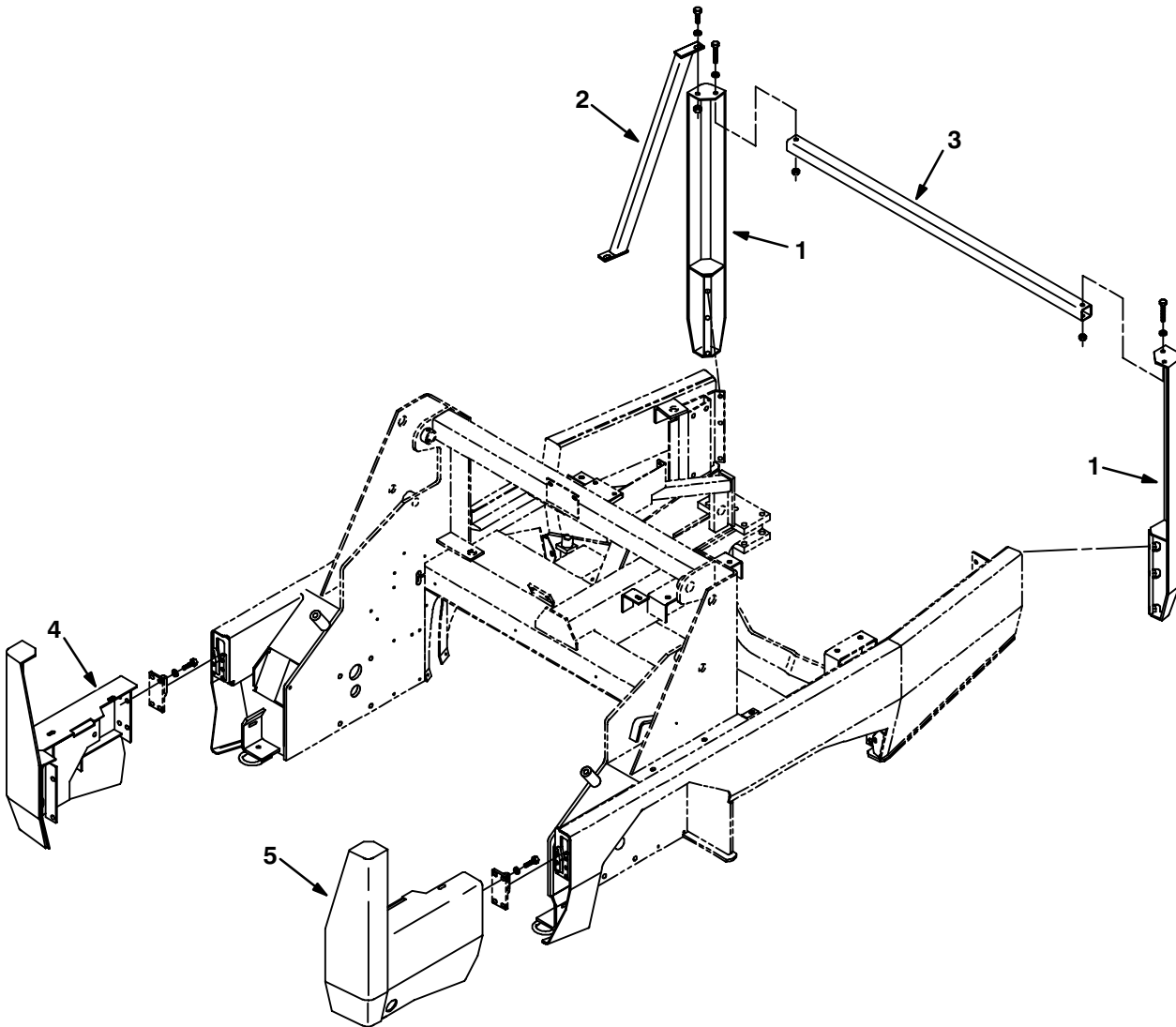

09908/09909

Ref.	Tennant Part No.	Machine Serial Number	Description	Qty.
∇	77545	(001185-001699)	Bumper Assy, Se	1
1	70802	(001185-001699)	Leg Wldt, Bumper, Se	2
2	70793	(001185-001699)	Brace Wldt, Bumper, Se	1
3	70815	(001185-001699)	Tube, Cross, Bumper, Se	1
4	77519	(001185-001699)	Bumper Wldt, Se, Rh, Front	1
5	77520	(001185-001699)	Bumper Wldt,Se, Lh, Front	1

Fig. 17 – Bumper Assembly, SE

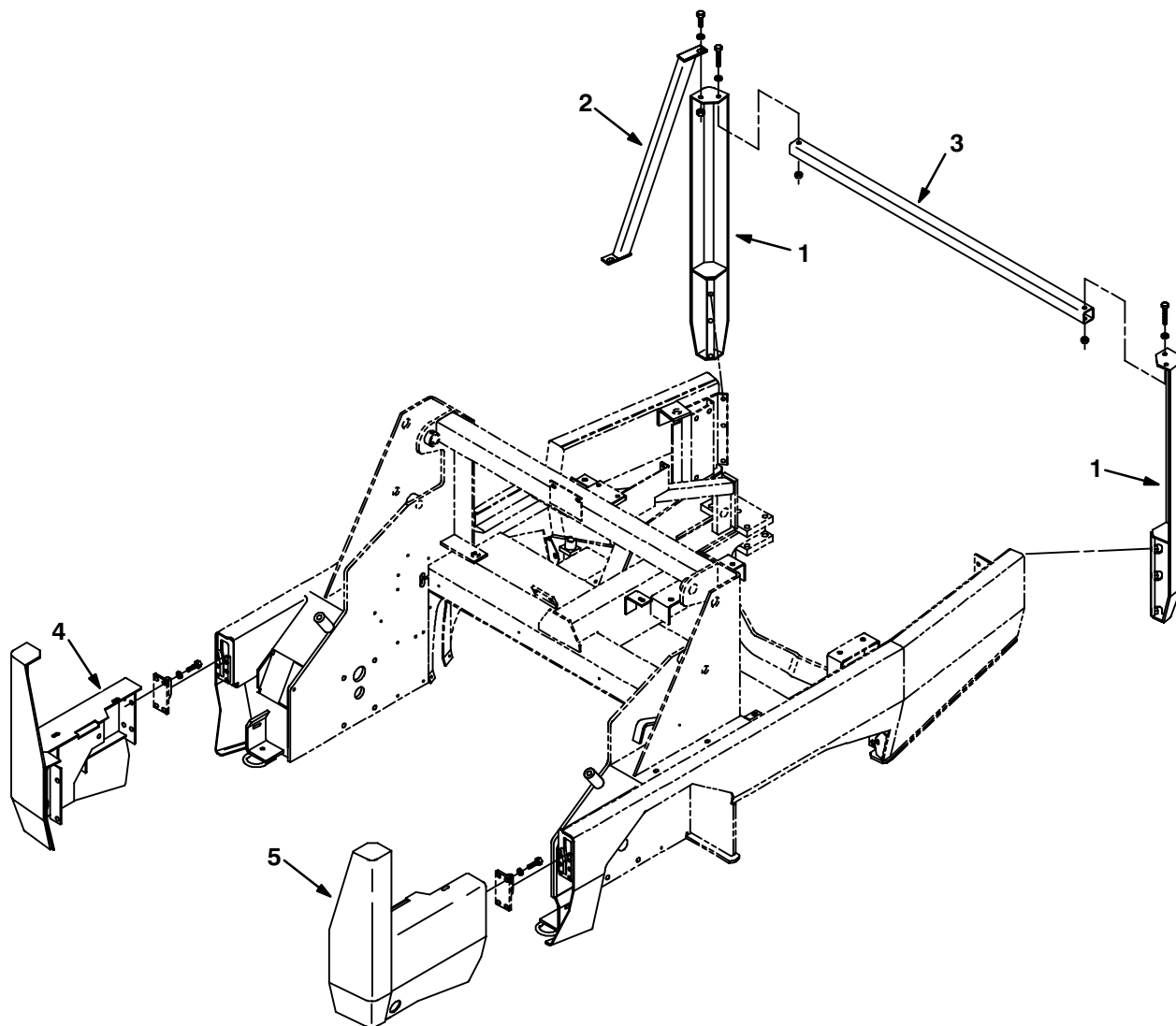

10506/09909

Ref.	Tennant Part No.	Machine Serial Number	Description	Qty.
∇	83557	(001700–)	Bumper Assy, Se	1
1	70802	(001700–)	Leg Wldt, Bumper, Se	2
2	70793	(001700–)	Brace Wldt, Bumper, Se	1
3	70815	(001700–)	Tube, Cross, Bumper, Se	1
4	83626	(001700–)	Bumper Wldt, Se, Rh, Front	1
5	83627	(001700–)	Bumper Wldt, Se, Lh, Front	1

Fig. 18 – Side Brush Lift Group, L.H.

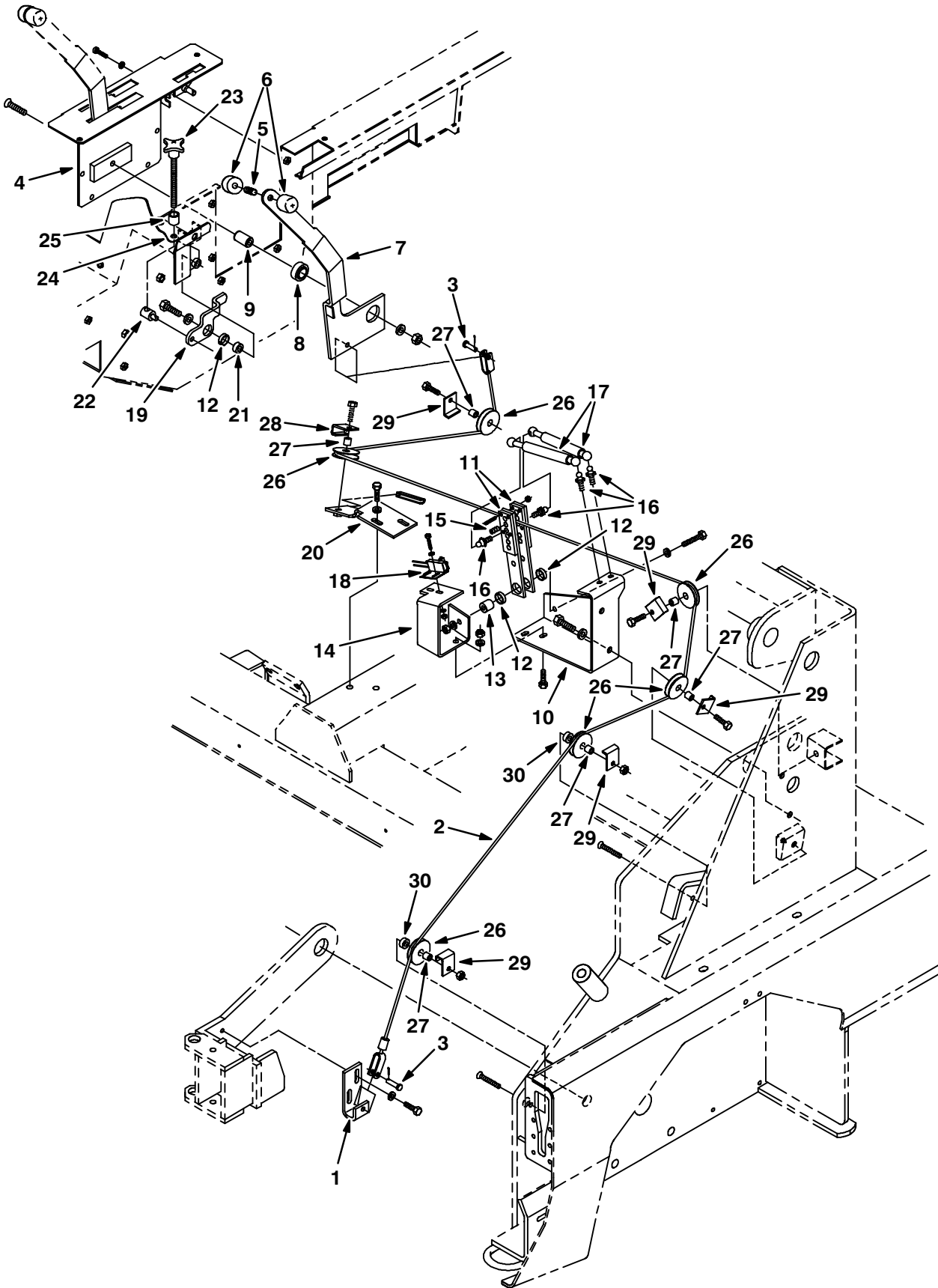

Fig. 18 – Side Brush Lift Group, L.H.

Ref.	Tennant Part No.	Machine Serial Number	Description	Qty.
1	75282	(000000-001176)	Bracket, Channel	1
2	75537	(000000-001176)	Cable Assy, Side Brush, Lift	1
3	69582	(000000-001176)	Pin,Clevis,0.31 Dia X 1.00 Lg	2
4	75065	(000000-001176)	Plate Wldt, Cover	1
5	75859	(000000-001176)	Rod-Thread, Full M10X1.5 X1.50	1
6	75857	(000000-001176)	Knob, Handle, Threaded	2
7	75022	(000000-001176)	Handle Wldt, Side Brush Lift	1
8	54663	(000000-001176)	Bearing, Self Aligning	1
9	75023	(000000-001176)	Spacer .77Od .406Id 1.318Lg	1
10	75491	(000000-001176)	Bracket Wldt	1
11	74031	(000000-001176)	Lever Wldt	2
12	74090	(000000-001176)	Bearing	3
13	73818	(000000-001176)	Sleeve, .375B .75D .75 Stl	1
14	75092	(000000-001176)	Bracket, Pivot	1
15	39338	(000000-001176)	Scr Set .31-18X0.50	1
16	58494	(000000-001176)	Stud, Ball, Gas Spring	4
17	73714	(000000-001176)	Strip, Retainer, Seal, Rh Gasspring	2
18	59962	(000000-001176)	Switch, Roller	1
19	70797	(000000-001176)	Lever	1
20	75082	(000000-001176)	Bracket, Mtg, Pulley	1
21	75894	(000000-001176)	Spacer	1
22	70444	(000000-001176)	Rod, Cam Adjuster	1
23	54848	(000000-001176)	Knob, Adjusting	1
24	52296	(000000-001176)	Washer,Nyl,0.405Bx0.812X.060Th	1
25	75892	(000000-001176)	Tube, .75D .172W .75 Stl	1
26	58279	(000000-001176)	Pulley – Cable, 1.5 Dia	6
27	56624	(000000-001176)	Spacer, Pulley	6
28	74899	(000000-001176)	Bracket, Cable Keeper	2
29	54400	(000000-001176)	Angle, Cable Keeper	4
30	73737	(000000-001176)	Sleeve, .375B .75D .32 Stl	2

Fig. 19 – Side Brush Lift Group, L.H.

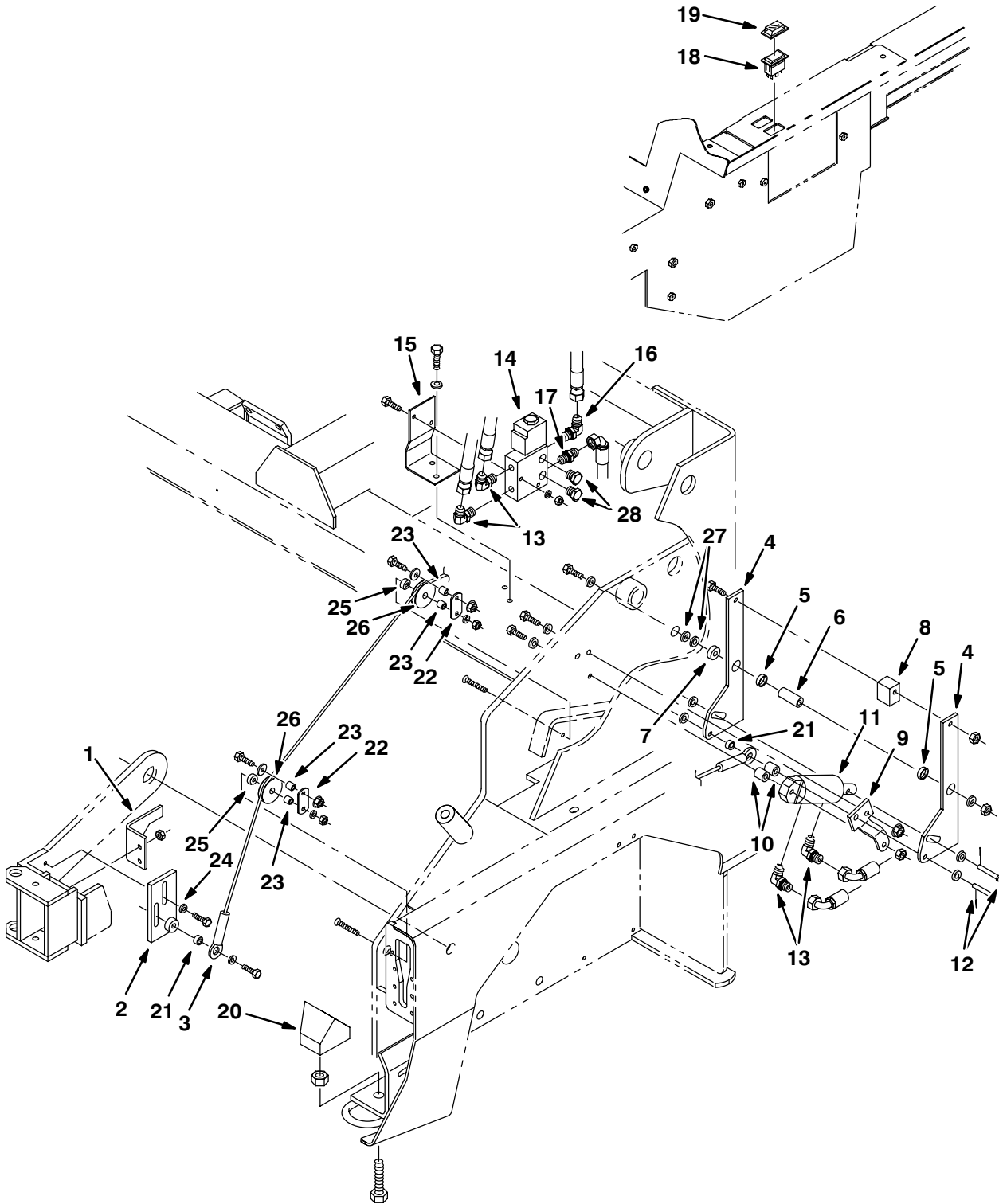

Fig. 19 – Side Brush Lift Group, L.H.

Ref.	Tennant Part No.	Machine Serial Number	Description	Qty.
1	77458	(001177-) Bracket, Angle	1
2	77569	(001177-) Plate Wldt	1
3	77568	(001177-) Cable, Side Brush, Lift	1
4	77584	(001177-) Plate	2
5	74090	(001177-) Bearing	2
6	77597	(001177-) Sleeve, 0.406B 0.75D1.80 Stl	1
7	77727	(001177-) Sleeve .438B 1.00D .35Stl	1
8	77459	(001177-) Spacer	1
9	77783	(001177-) Plate, Angle	1
10	77600	(001177-) Sleeve, 0.406B .750D .800Stl	2
11	77599	(001177-) Cylinder, Hyd 1.5B 1.5S 2500	1
12	51813	(001177-) Pin,Clevis,0.37 Dia.X 2.12 Lg	2
13	77097	(001177-) Ftg-Hyd E90 Jm04/Om04	4
14	77771	(001177-001699) Valve, Hyd, Control Solenoid	1
14	84016	(001700-) Valve, Hyd, Solenoid (See Breakdowns)	1
15	21231	(001177-) Bracket, Side Brush, Valve	1
16	56820	(001177-) Ftg-Hyd E90 Jm06/Om06	1
17	56690	(001177-) Ftg-Hyd Str Jm06/Om06	1
18	65561	(001177-) Switch Rocker Spst	1
19	57807	(001177-) Cover, Rocker Switch Seal	1
20	77738	(001177-) Block	1
21	65174	(001177-) Spacer	2
22	79115	(001177-) Plate, Side Brush, Roller	2
23	56624	(001177-) Spacer, Pulley	4
24	41186	(001177-) Washer-Belleville .31 Pltd	1
25	73737	(001177-) Sleeve, .375B .75D .32 Stl	2
26	58279	(001177-) Pulley – Cable, 1.5 Dia	2
27	32492	(001177-) Flat Washer, 3/8" Hard	2
28	46482	(001700-) Ftg-Hyd Plg Om06	2

Fig. 20 – Side Brush Group, L.H.

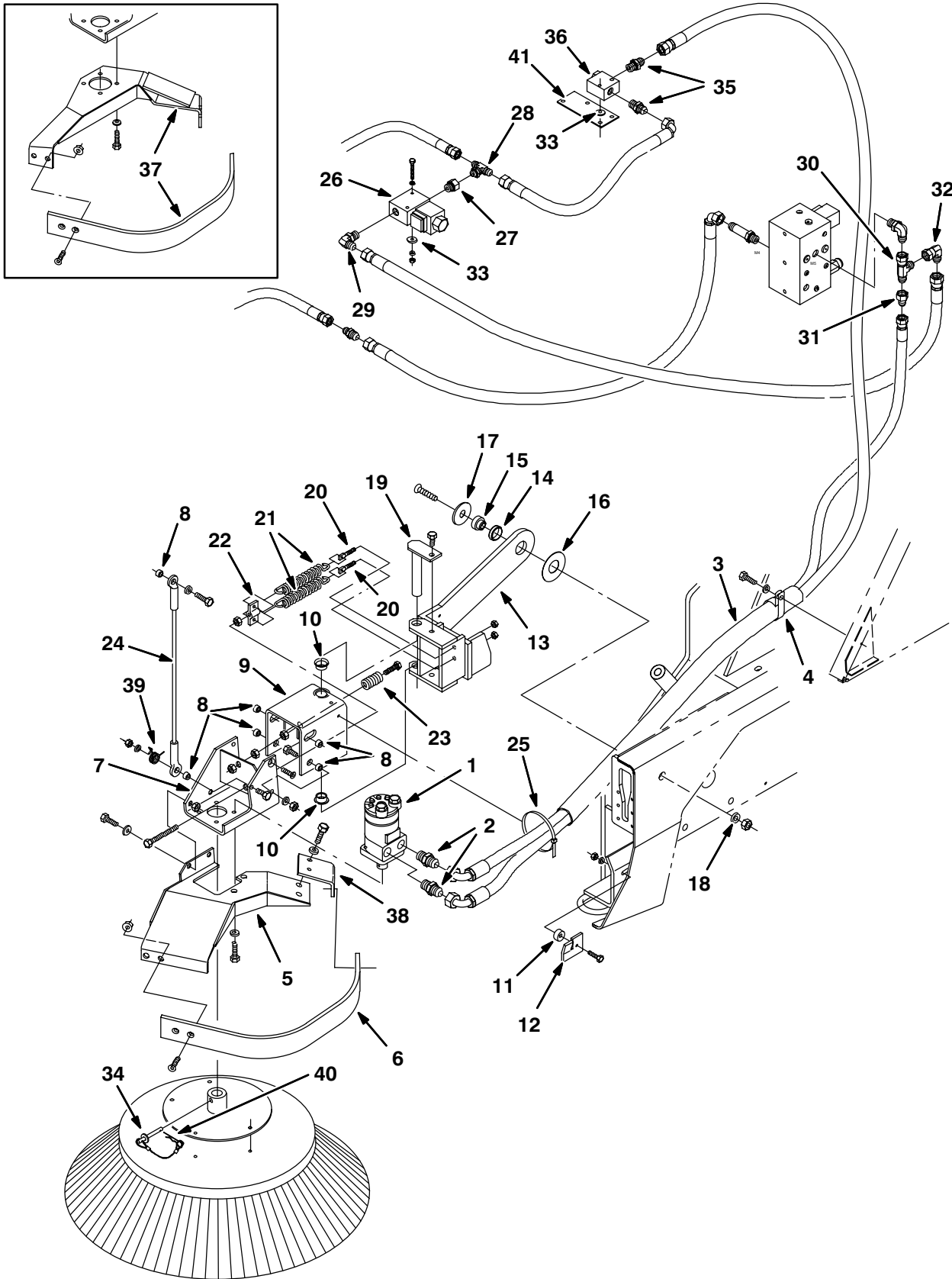
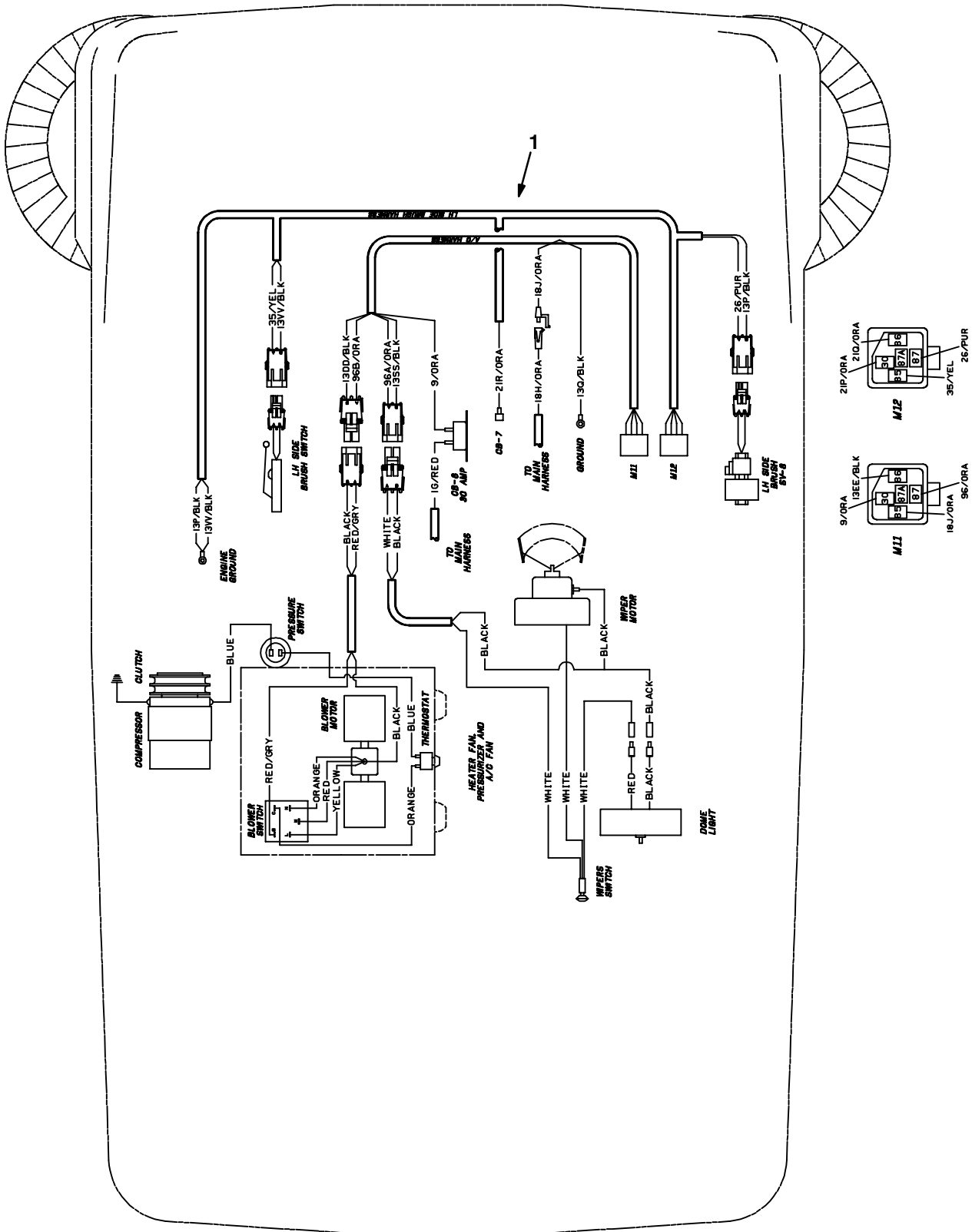

Fig. 20 – Side Brush Group, L.H.

Ref.	Tennant Part No.	Machine Serial Number	Description	Qty.
1	62564	(000000–001477)	Motor, Hyd (Repl. By 79781) (See Breakdowns)	1
1	79781	(001478–)	Motor, Hyd Gear In 17.9 B 1500 (See Breakdowns)	1
2	47508	(000000–)	Ftg–Hyd StrJm06/Om10	2
3	76461	(000000–)	Sleeve, Nylon #27 55.OI	1
4	86328	(000000–)	Clamp, Cable 1.5 Dia	1
5	21250	(001340–)	Guard Wldt, Sidebrush	1
6	21252	(001340–)	Guard, Side Brush	1
7	75142	(000000–)	Bracket, Mounting, Motor	1
8	65174	(000000–)	Spacer	6
9	75099	(000000–)	Bracket Wldt, Pivot	1
10	04761	(000000–)	Bearing, Flange .875 Bore	2
11	74059	(000000–)	Spacer	1
12	75899	(000000–)	Bracket, Angle	1
13	75117	(000000–)	Bracket Wldt, Lift	1
14	70627	(000000–)	Bearing	1
15	70526	(000000–)	Shaft, Pivot	1
16	70524	(000000–)	Washer, 1.300B 3.000	1
17	70525	(000000–)	Spacer	1
18	36328	(000000–)	Washer–Belleville .50 Pltd	1
19	70431	(000000–)	Pin	1
20	70626	(000000–)	Bolt–Eye M8–1.25	2
21	65160	(000000–)	Spring, Extension	2
22	65173	(000000–)	Bracket, Spring	1
23	65180	(000000–)	Spring, Comp	1
24	70532	(000000–)	Cable, Retaining, Side Brush	1
25	49263	(000000–)	Tie Cable 3.00D Max 11.41Lg	1
26	65391	(000000–001699)	Valve–Hyd, Solenoid (See Breakdowns)	1
26	84015	(001700–)	Valve–Hyd, Solenoid (See Breakdowns)	1
27	47637	(000000–)	Ftg–Hyd Str Om08/Of06	1
28	67683	(000000–)	Ftg–Hyd Tee Jm06Omjm	1
29	44868	(000000–)	Ftg–Hyd E90 Jm08/Om08	1
30	45482	(000000–)	Ftg–Hyd Tee Jm08Jmjf	1
31	47753	(000000–)	Ftg–Hyd Str Jm06/Jf08	1
32	17980	(000000–)	Ftg–Hyd E90 Jm08/Jf08	1
33	63416	(000000–)	Washer, .310B .88D .12Rbr	4
34	21035	(000000–)	Pin Assy, .312X3.0 W/Lanyard	1
35	56690	(000000–)	Ftg–Hyd Str Jm06/Om06	2
36	79621	(000000–)	Check Valve, 100 Psi	1
37	21253	(000000–001339)	Guard Replmt Kit Side Brush Lh	1
38	21251	(001340–)	Plate, Angle	1
39	79124	(000000–)	Spring, Torsion	1
40	44906	(000000–)	Pin,Hair Cotter #Lhcot–2,Leitk	1
41	79622	(000000–)	Plate, Mtg, Check Valve	1

Fig. 21 – Side Brush Wire Harness Group, L.H.



08776/08564

Ref.	Tennant Part No.	Machine Serial Number	Description	Qty.
1	77726	(00000-001699)	Harness, Side Brush, L.H.	1

Fig. 22 – Side Brush Wire Harness Group, L.H.

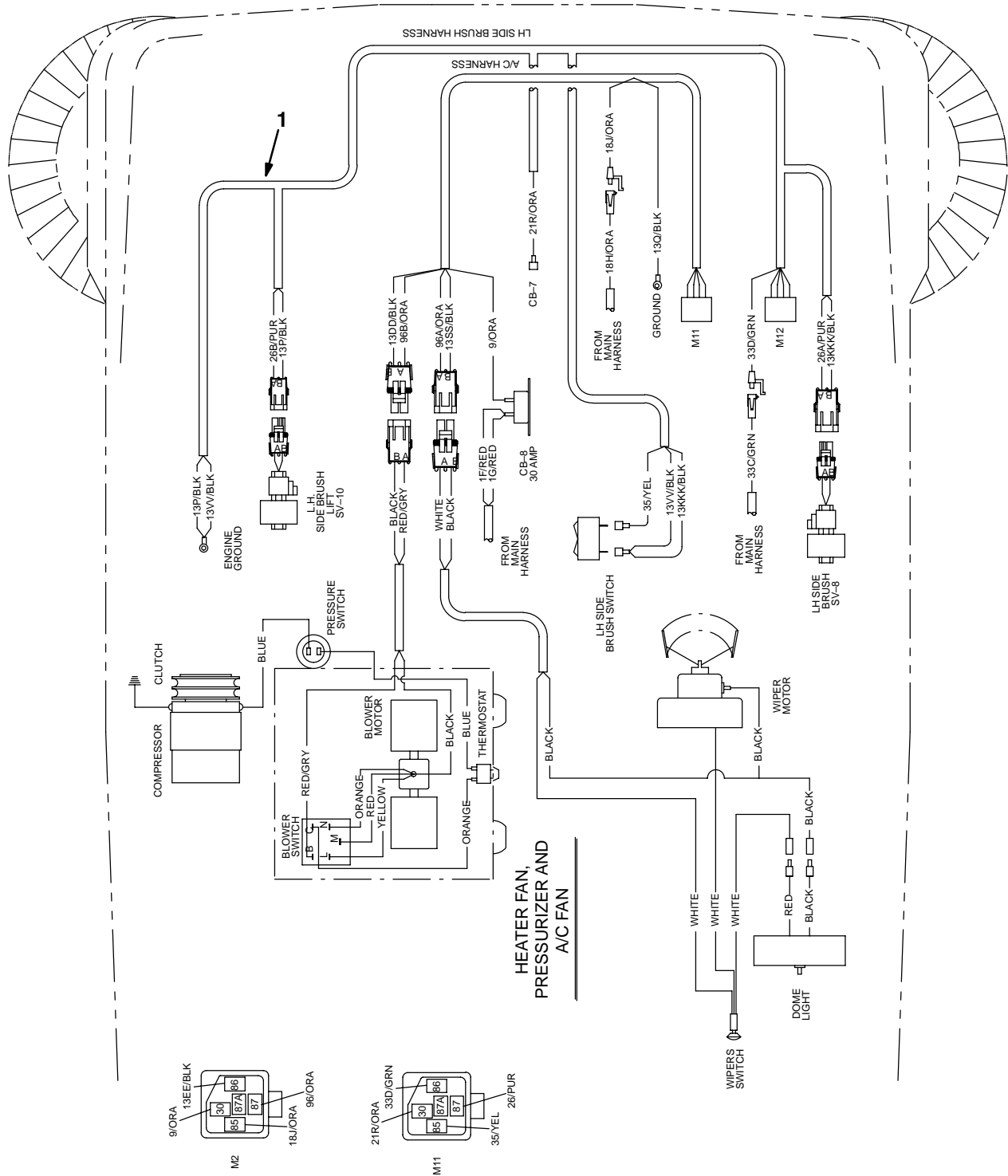

10505/10501

Ref.	Tennant Part No.	Machine Serial Number	Description	Qty.
1	83699	(001700–)	Harness, Side Brush, L.H.	1

Fig. 23 – Side Brush Hydraulic Hose Group, L.H.

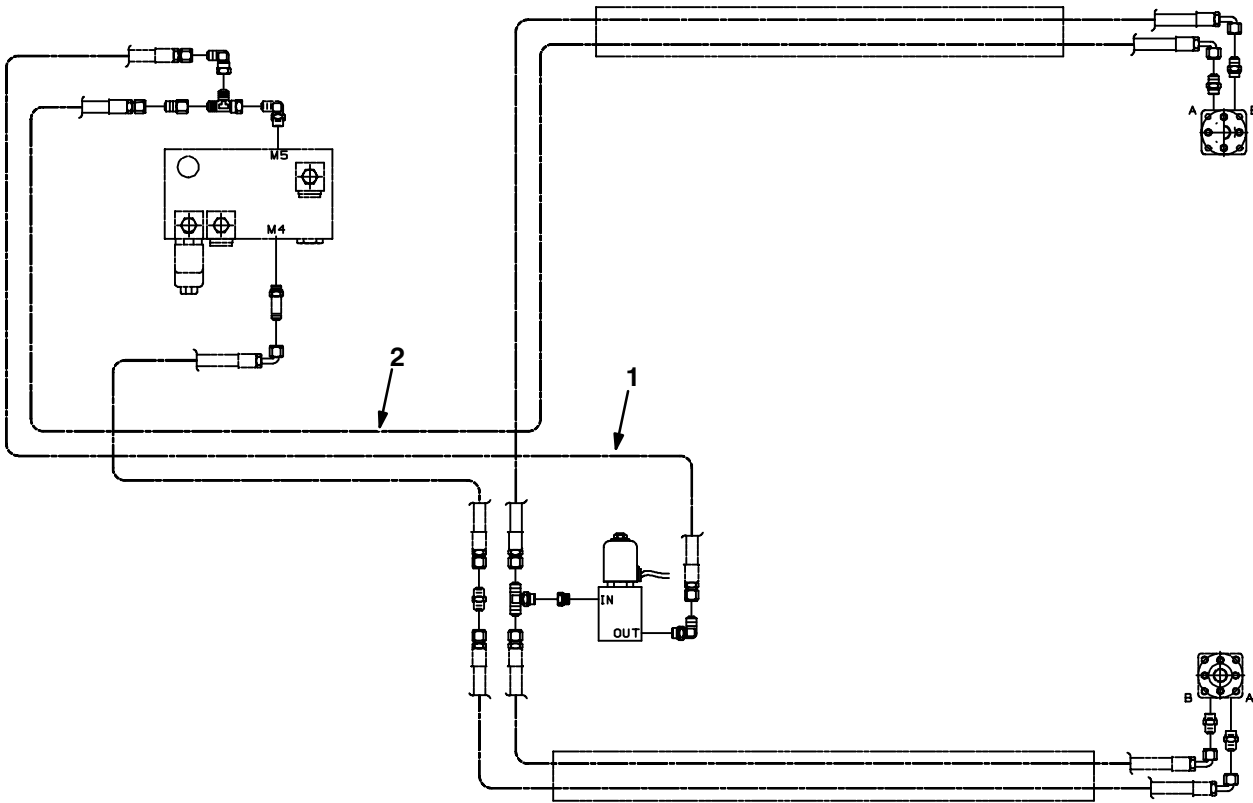

08762/08763

Ref.	Tennant Part No.	Machine Serial Number	Description	Qty.
1	76684	(000000-001176)	Hose-Hyd Med06 Jf/J9	1
2	31597	(000000-001176)	Hose-Hyd Med06 Jf/J9	1

Fig. 24 – Side Brush Hydraulic Hose Group, L.H.

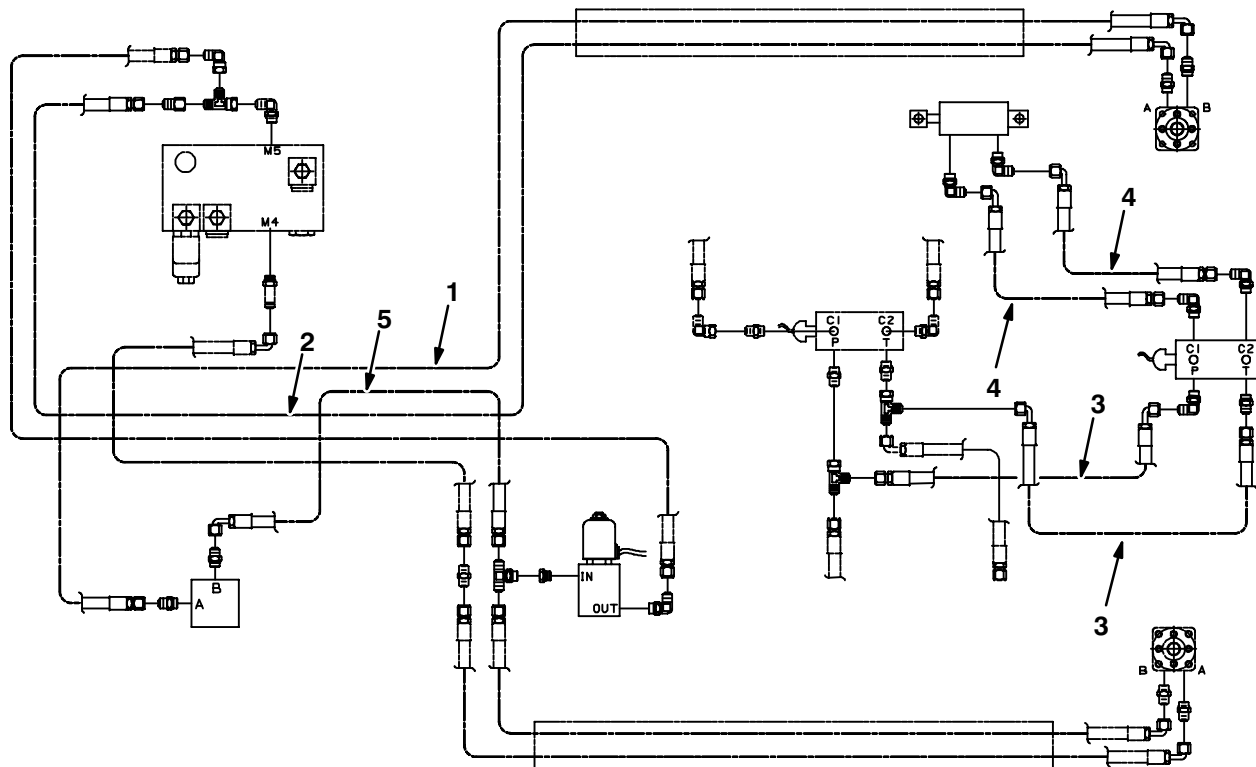

09913/08763

Ref.	Tennant Part No.	Machine Serial Number	Description	Qty.
1	76684	(001177-) Hose-Hyd Med 06	1
2	65194	(001177-) Hose-Hyd Med 06	1
3	78998	(001177-) Hose-Hyd Med 06	2
4	57963	(001177-) Hose-Hyd Med 04	2
5	01999	(001259-) Hose-Hyd Med 06	1

Fig. 25 – Side Brush Light Group

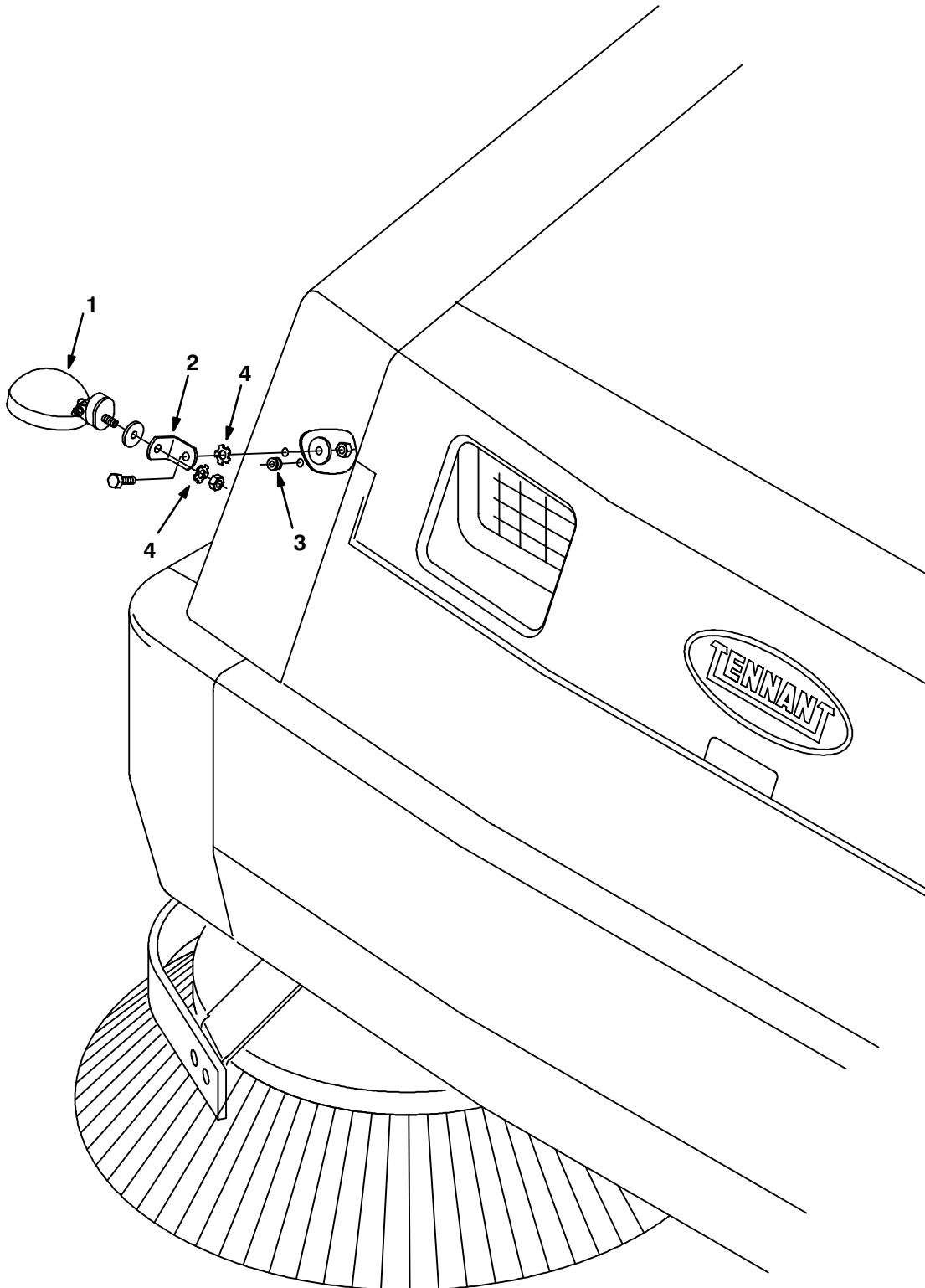

Fig. 25 – Side Brush Light Group

Ref.	Tennant Part No.	Machine Serial Number	Description	Qty.
∇	70699	(000000–) Light Kit, Side Brush	1
1	61424	(000000–) Light, Spot Hi–D 255li L	1
2	76385	(000000–) Bracket, Angle	1
3	10632–5	(000000–) Grommet Rbr 0.25ld For .09Matl	1
4	41141	(000000–) Washer–Loc Int–Ext .31 Pltd	2

Fig. 26 – Cab Group

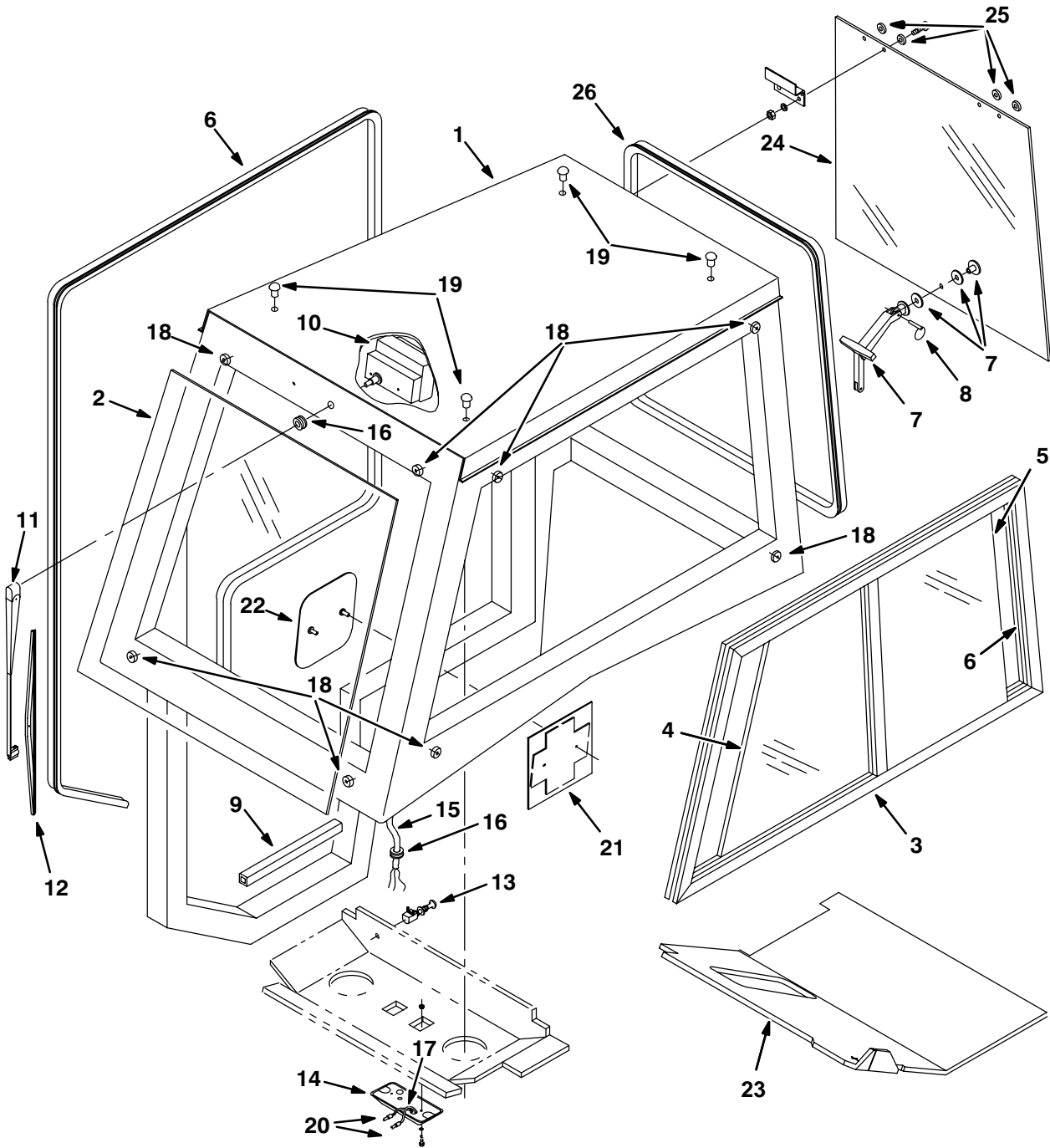

Fig. 26 – Cab Group

Ref.	Tenant Part No.	Machine Serial Number	Description	Qty.
1	75820	(000000–)	Cab Body	1
2	75822	(000000–)	Glass, Windshield	1
∇ 3	75823	(000000–)	Glass, Sliding, Lh	1
4	21307	(000000–)	Fmnt Glass Asy–Cab	1
5	21308	(000000–)	Rear Glass Asy–Cab	1
6	21309	(000000–)	Frame Asy–Cab	1
7	76950	(000000–)	Latch, Rear Wind	1
8	76971	(000000–)	Ring, Rear Window	1
9	76973	(000000–)	Seal Cw	1
10	76977	(000000–)	Motor, Wiper 12V	1
11	76980	(000000–)	Arm, Rear Wiper	1
12	76982	(000000–)	Blade Arm, Rear	1
13	76985	(000000–)	Switch, Wiper Motor	1
14	76996	(000000–)	Light, Dome 12V	1
15	77810	(000000–)	Harness, Wire	1
16	77811	(000000–)	Grommet	2
17	77812	(000000–)	Wire, Dome Light	2
18	77813	(000000–)	Spacer	8
19	77814	(000000–)	Closure	4
20	77815	(000000–)	Disconnect, Male	2
21	70785	(000000–)	Bracket Wldt, Cab, Lpg	1
22	70788	(000000–)	Cover, Cab, Lpg	1
23	76522	(000000–)	Tread, Floormat, Rubber, Cab	1
24	75824	(000000–)	Glass, Rear	1
25	75825	(000000–)	Spacer, Glass	4
26	76948	(000000–)	Gasket, Push On	1
	21310	(000000–)	Seal Kit, Cab	1

Fig. 27 – Cab Door Assembly

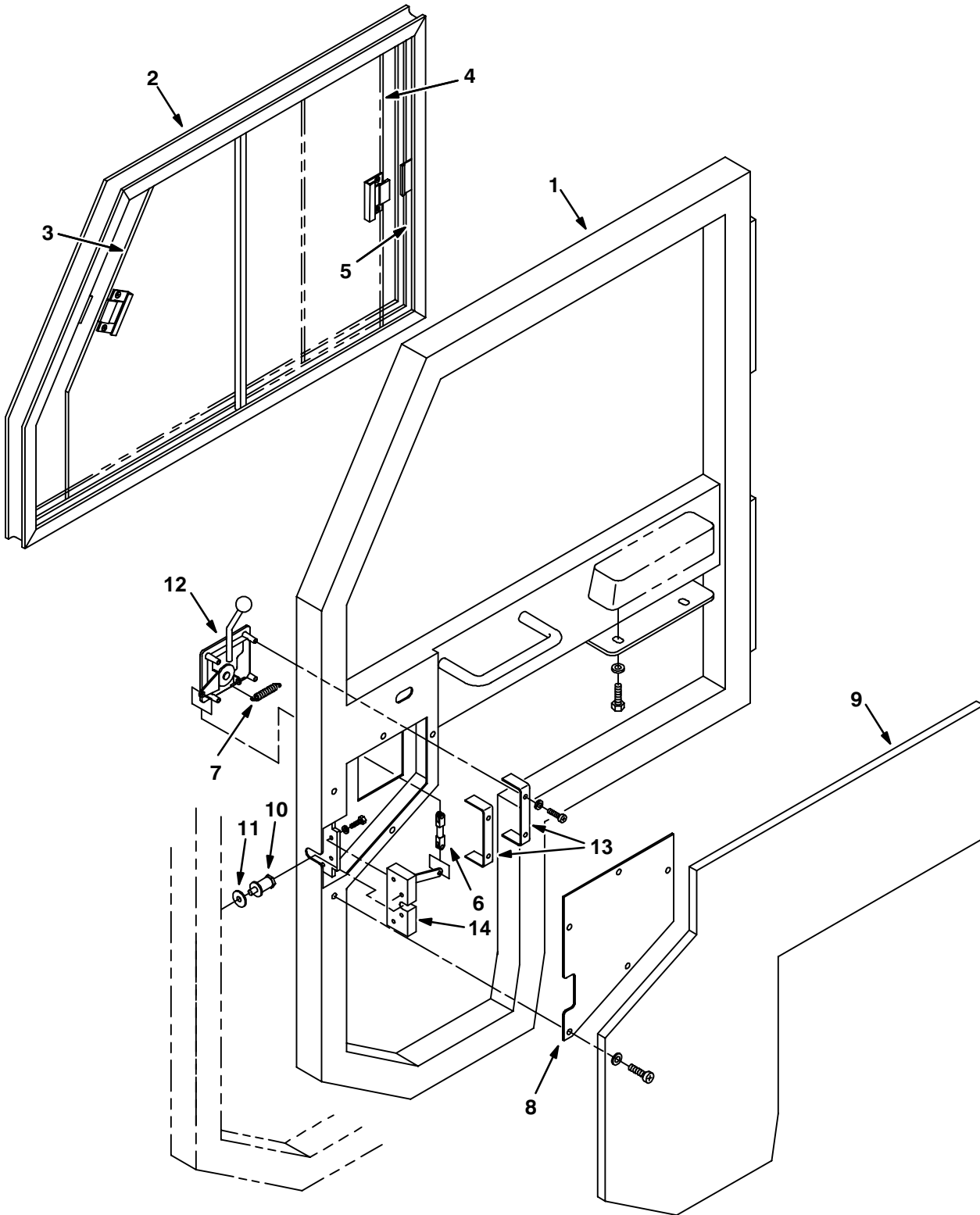

Fig. 27 – Cab Door Assembly

Ref.	Tenant Part No.	Machine Serial Number	Description	Qty.	
∇	75821	(000000–) Door Group	1	
1	77816	(000000–) Door Cw	1	
∇	2	77817	(000000–) Sliding Glass	1
3	21311	(000000–) Frnt Glass Asy–Door	1	
4	21312	(000000–) Rear Glass Asy–Door	1	
5	21313	(000000–) Frame Assy–Door	1	
6	77821	(000000–) Link, Connecting	1	
7	77822	(000000–) Pin Assy, Spring	2	
8	77823	(000000–) Plate	1	
9	77824	(000000–) Foam, Door	1	
10	76975	(000000–) Striker Assy	1	
11	76976	(000000–) Shim, Door Striker	2	
∇	12	77818	(000000–) Paddle Handle	1
	21150	(000000–) Key Set	1	
13	77819	(000000–) Bracket	2	
14	77820	(000000–) Clam Latch	1	

Fig. 28 – Cab Insulation Group

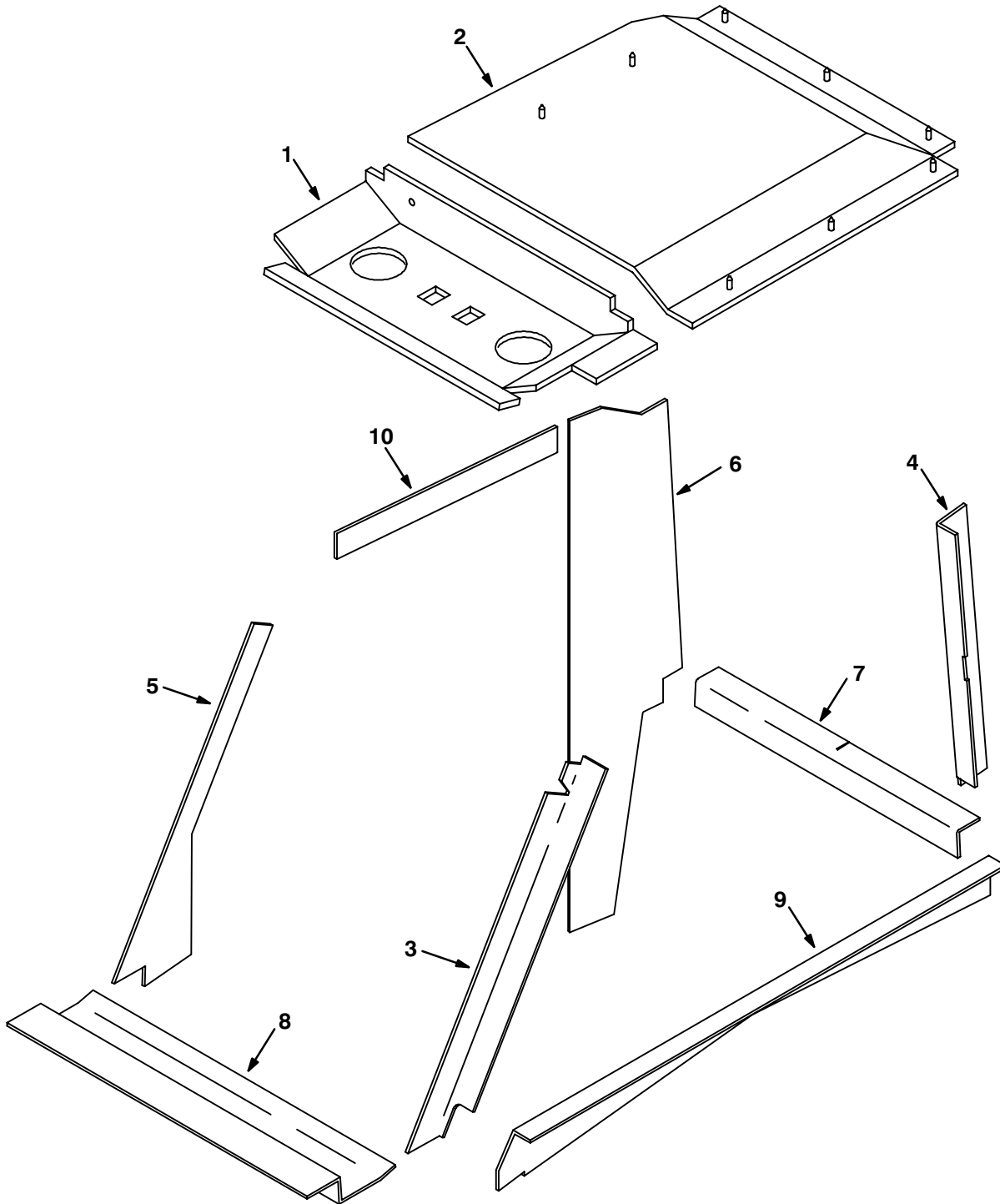

Fig. 28 – Cab Insulation Group

Ref.	Tenant Part No.	Machine Serial Number	Description	Qty.
1	77800	(000000–)	Headliner, Front	1
2	77801	(000000–)	Headliner, Rear Cw	1
3	77802	(000000–)	Foam, Lh Front Pos	1
4	77803	(000000–)	Foam, Lh Rear Pos	1
5	77804	(000000–)	Foam, Rh Front Pos	1
6	77805	(000000–)	Foam, Rh Rear Pos	1
7	77806	(000000–)	Foam, Rear Sill	1
8	77807	(000000–)	Foam, Front Sill	1
9	77808	(000000–)	Foam, Lh Side Sill	1
10	77809	(000000–)	Foam, Rh Upper Sill	1

Fig. 29 – Mirror Kit

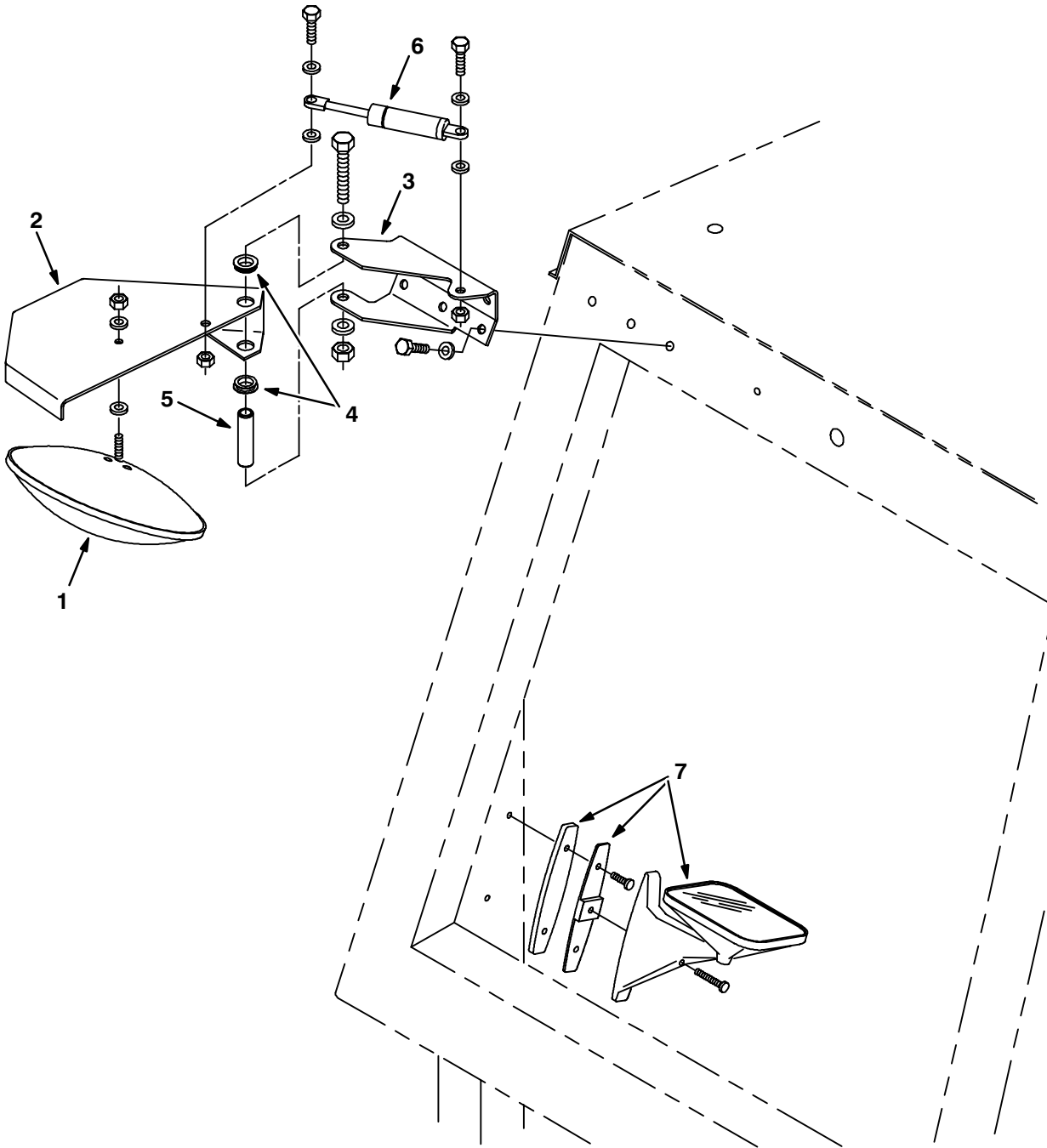

Fig. 29 – Mirror Kit

Ref.	Tennant Part No.	Machine Serial Number	Description	Qty.
∇	76898	(000000–) Mirror Kit, Side Brush	1
1	68445	(000000–) Mirror,8.0 Round,Convex	1
2	75881	(000000–) Guard, Mirror	1
3	75880	(000000–) Bracket, Mounting, Mirror	1
4	41434	(000000–) Bshg,Flange,0.62Bx0.68Od,Nylon	2
5	70761	(000000–) Tube, 0.62D .44B 2.44, Stl	1
6	12549	(000000–) Spring, Gas 80 Lb	1
7	75882	(000000–) Mirror, Side Brush	1

Fig. 30 – Air Cleaner Assembly, Air Conditioner

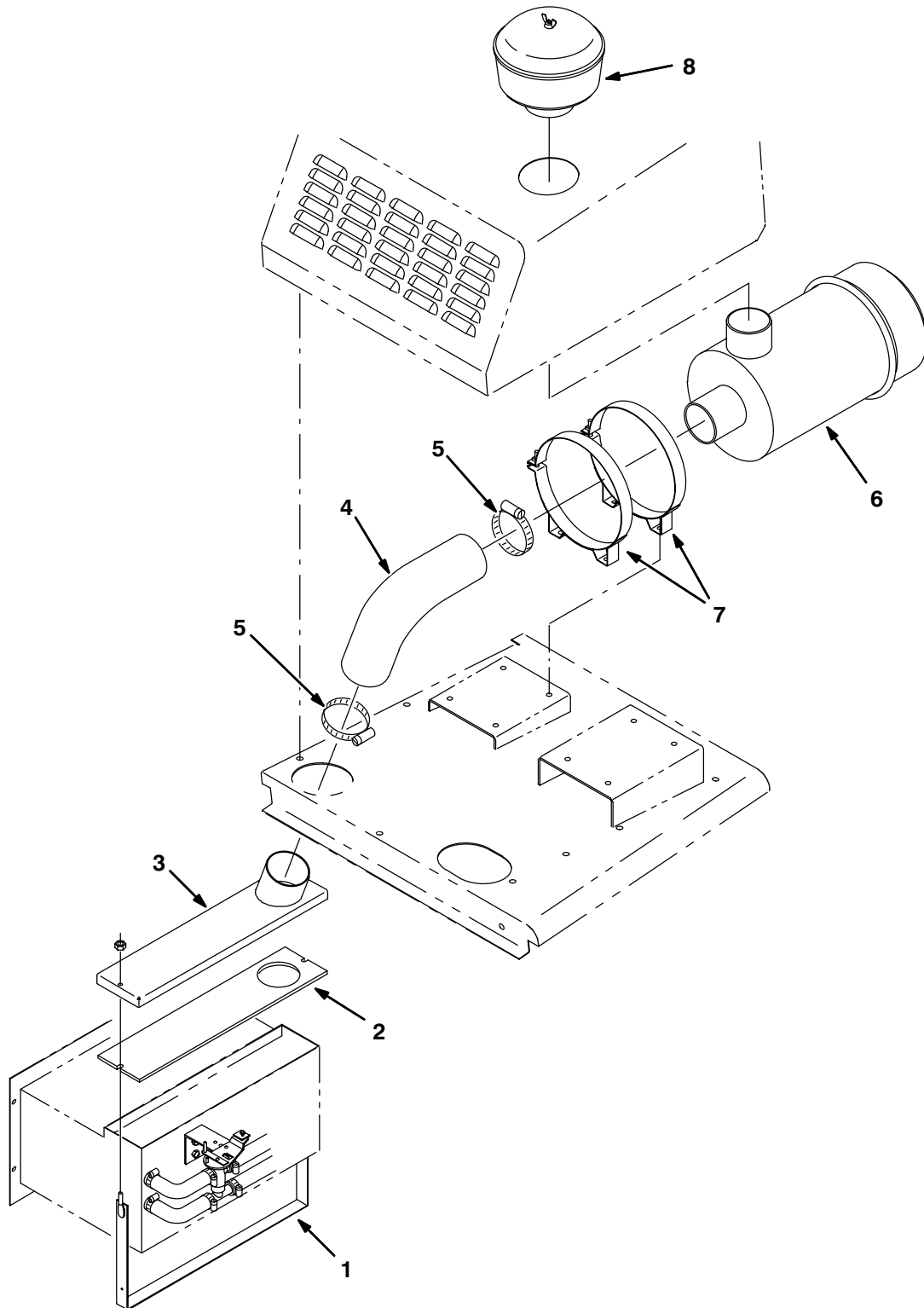

Fig. 30 – Air Cleaner Assembly, Air Conditioner

Ref.	Tennant Part No.	Machine Serial Number	Description	Qty.
∇	75890	(000000–) Air Cleaner Assy, Air Cond	1
1	75875	(000000–) Strap Wldt, A/C Cover	1
2	21216	(000000–) Gasket, Air Cond Box	1
3	75192	(000000–) Cover Wldt, Air Cond Box	1
4	75304	(000000–) Hose, Rubber, Elbow	1
5	43555	(000000–) Clamp–Wormdrive, 1.62– 3.50D	2
6	75609	(000000–) Filter, Air, A/C	1
7	75606	(000000–) Strap, Mtg, Air Cleaner	2
8	75666	(000000–) Filter, Pre–Cleaner, A/C	1

Fig. 31 – Air Conditioner Group

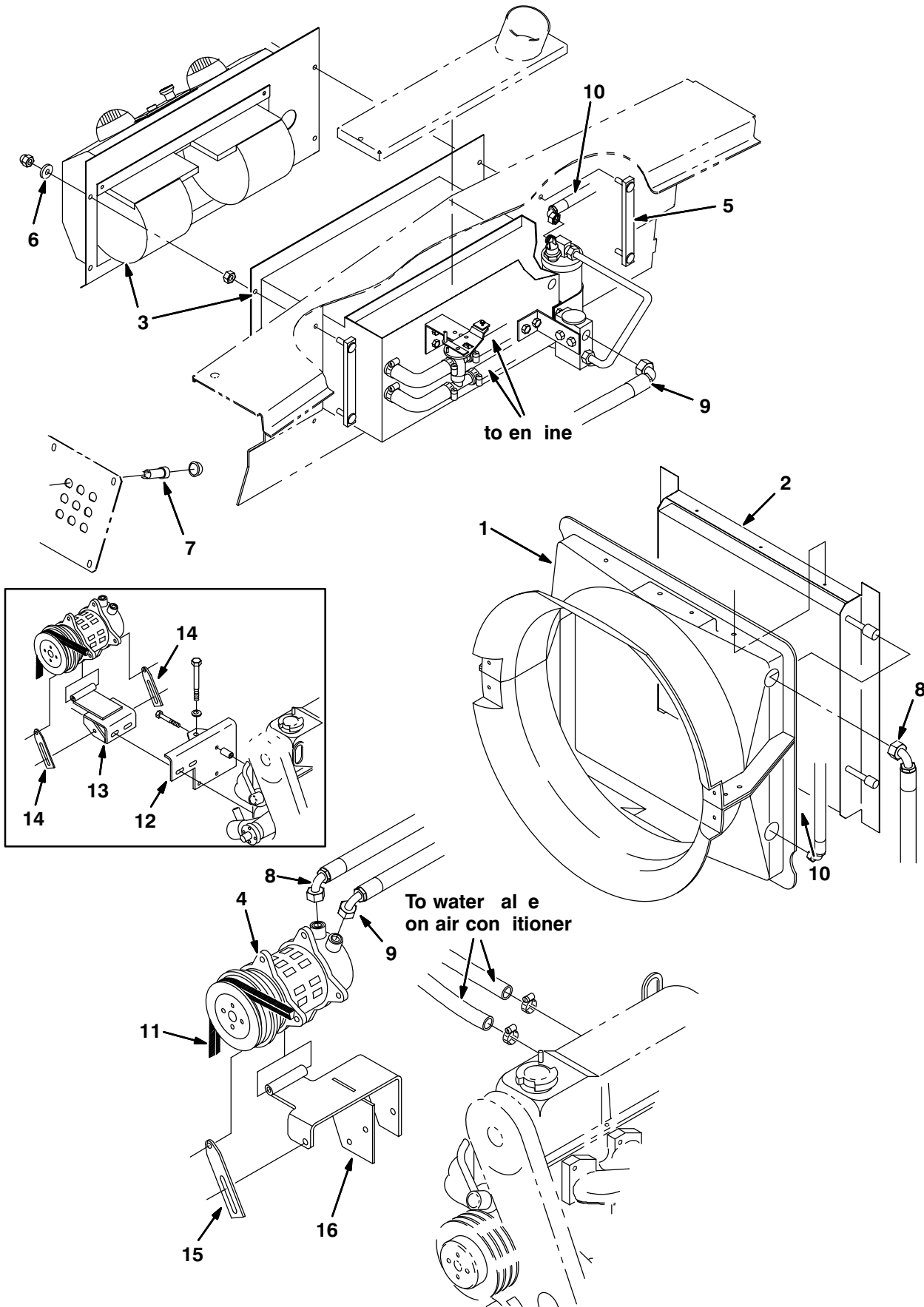

Fig. 31 – Air Conditioner Group

Ref.	Tennant Part No.	Machine Serial Number	Description	Qty.
1	75866	(000000–)	Duct, Fan, Ac	1
2	73858	(000000–)	Condensor, Air Conditioner	1
3	77675	(000000–001397)	Air Conditioner, A 134 (Repl. By 21270) (See Breakdowns)	1
3	21270	(001398–)	Air Conditioner 134R Recirc (See Breakdowns)	1
4	77869	(000000–001157)	Compressor R12	1
4	77674	(001158–)	Compressor, A/C	1
5	75884	(000000–)	Strip	2
6	41128	(000000–)	Nut–Low Crown .31–18 Pltd	4
7	76473	(000000–)	Breaker–Circuit, 30 Thermal	1
	76437	(000000–)	Harness, Air Conditioner	1
∇	8	21277	(000000–001157) A/C Hose #8 R12 De	1
		32134	(000000–001157) O–Ring, #8	2
∇	8	21274	(001158–) Hose, A/C #8 134A	1
		32134	(001158–) O–Ring, #8	2
∇	9	21278	(000000–001157) A/C Hose #10 R12 De	1
		32147	(000000–001157) O–Ring	2
∇	9	21275	(001158–) Hose, A/C #10	1
		32147	(001158–) O–Ring	2
∇	10	21276	(000000–001157) A/C Hose #6 R12 De	1
		32133	(000000–001157) O–Ring #6	4
∇	10	21273	(001158–) A/C Hose #6 134A De	1
		32133	(001158–) O–Ring #6	4
	11	36548	(000000–) V–Belt, A–45 Hy–T	1
	12	75900	(000000–001699) Plate Wldt	1
	13	75898	(000000–001699) Angle Wldt	1
	14	73717	(000000–001699) Link, Tension	2
	15	83645	(001700–) Link, Tension 5.2 Lg	1
	16	83726	(001700–) Bracket, Wldt, Mtg A/c Comp	1

Fig. 32 – Heater/Pressurizer Assembly

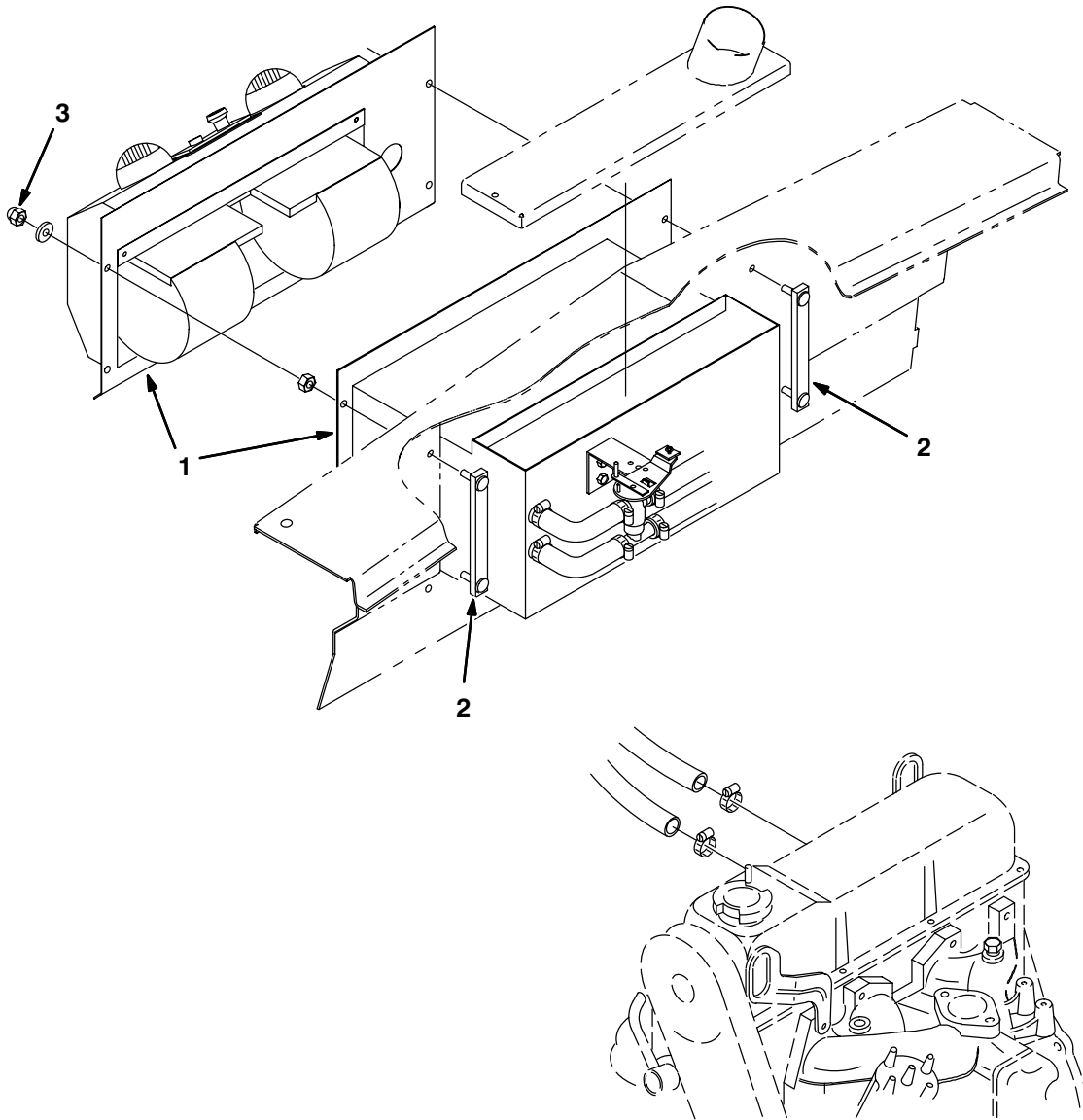

Fig. 32 – Heater/Pressurizer Assembly

Ref.	Tennant Part No.	Machine Serial Number	Description	Qty.
∇	76245	(000000–)	Heater/Pressurizer Assy	1
1	74091	(000000–001397)	Heater, Pressurizer Grp (Repl. By 21271) (See Breakdowns)	1
1	21271	(001398–)	Heater, Pressurizer Group (See Breakdowns)	1
2	75884	(000000–)	Strip	2
3	41128	(000000–)	Nut–Low Crown .31–18 Pltd	4
	76437	(000000–)	Wire Harness	1

Fig. 33 – Alternator Group, SE

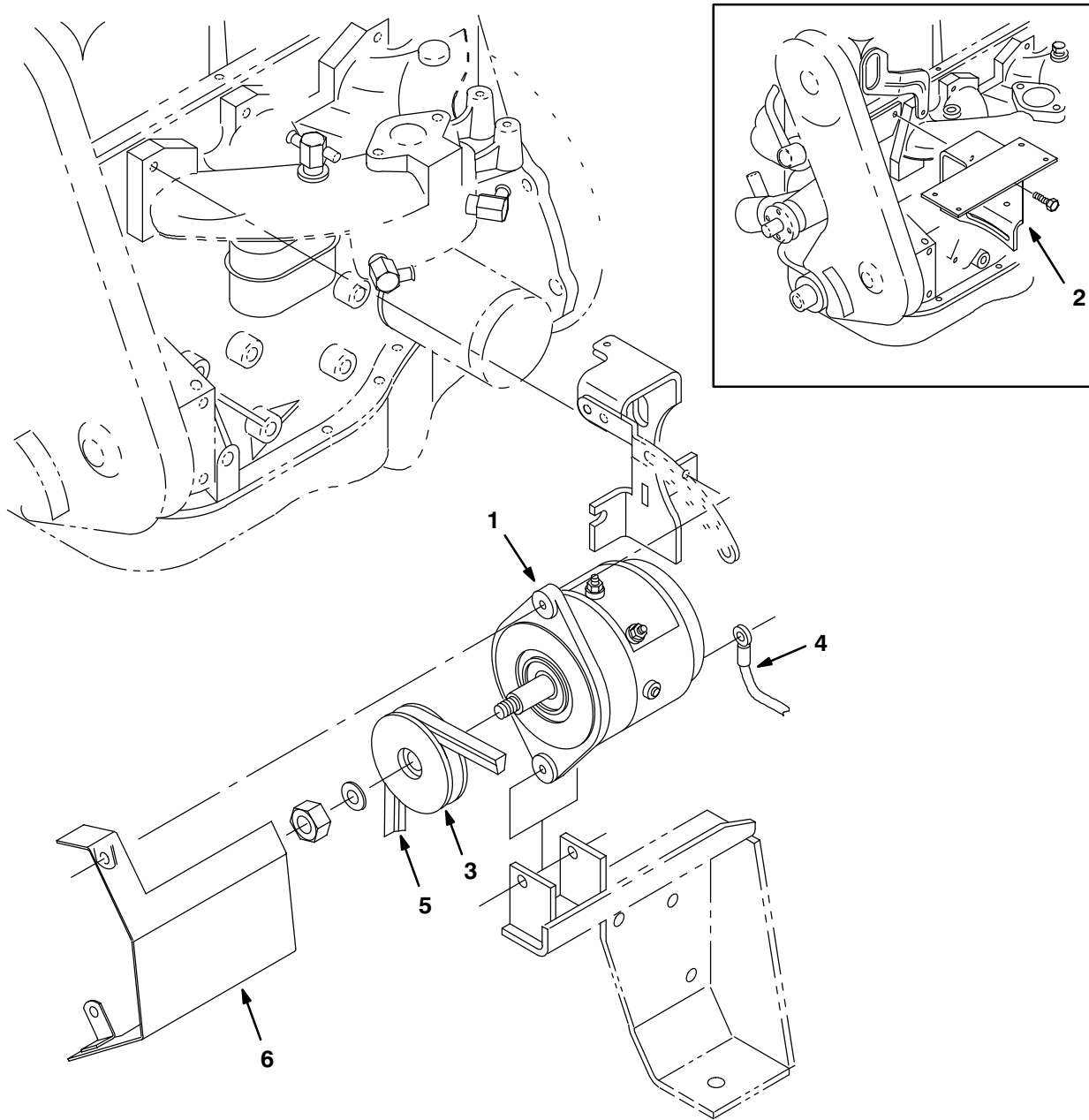

Fig. 33 – Alternator Group, SE

Ref.	Tennant Part No.	Machine Serial Number	Description	Qty.
1	75828	(000000–)	Alternator	1
2	75829	(000000–001699)	Bracket Wldt, Alternator, Top	1
3	77555	(000000–)	Sheave, Alternator, Se	1
4	31525	(000000–)	Wire, Ground, Alternator	1
5	75833	(000000–)	Belt, V .47, 45.1 Long	1
6	21223	(000000–)	Guard Wldt	1
	65222	(000000–)	Sender, Filter, Hydraulic	1

Fig. 34 – Vacuum Wand Kit

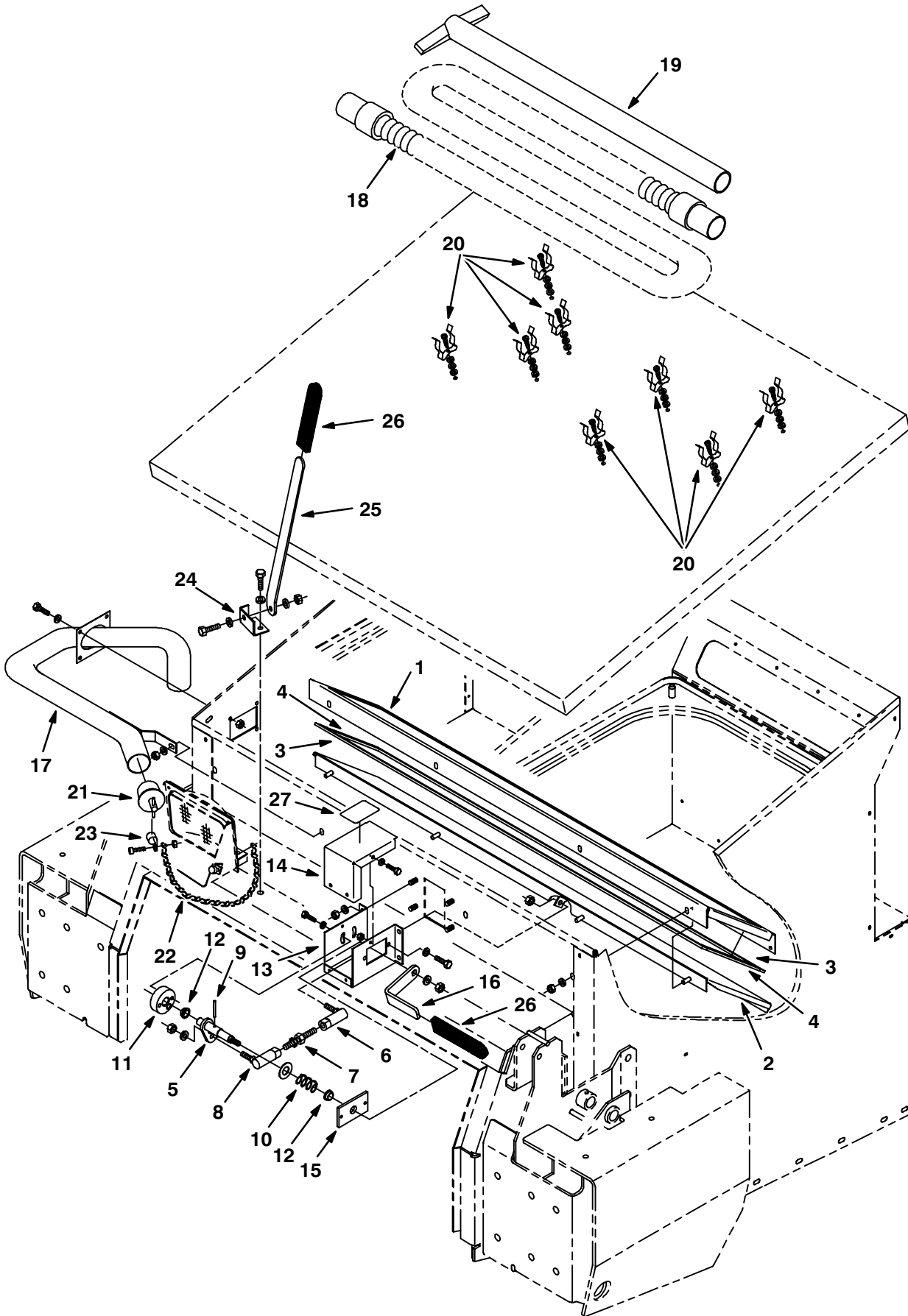

Fig. 34 – Vacuum Wand Kit

Ref.	Tennant Part No.	Machine Serial Number	Description	Qty.
∇	70668	(000000–001247)	Wand Kit, Vacuum	1
1	73871	(000000–001247)	Plate, Mounting, Vac Door	1
2	75701	(000000–001247)	Plate Wldt, Vac Door	1
3	75876	(000000–001247)	Seal, Foam Rbr, .19 .75W 47.1L	2
4	75877	(000000–001247)	Seal, Foam Rbr .19 .75W 8.43L	2
5	74083	(000000–001247)	Shaft Wldt	1
6	82962	(000000–001247)	Balljoint .375–24 Lh	1
7	11676	(000000–001247)	Stud, Adjustment	1
8	51531	(000000–001247)	Ball Joint .375–24	1
9	23146	(000000–001247)	Pin,Roll,.18Odx1.62L,.187/.192	1
10	19035	(000000–001247)	Sprng,Comp,0.83ldx.07Wire 1.0L	1
11	73884	(000000–001247)	Disk, Adjusting	1
12	04843	(000000–001247)	Bearing, Flange .625 Bore	2
13	73877	(000000–001247)	Panel, Cover	1
14	73878	(000000–001247)	Panel, Cover	1
15	73880	(000000–001247)	Plate	1
16	73883	(000000–001247)	Handle	1
17	74074	(000000–001247)	Adaptor Wldt, Vac Wand	1
18	54009	(000000–001247)	Hose&2Cuff Assy,Vinyl2.0ld10Ft	1
19	54012	(000000–001247)	Wand	1
20	36158	(000000–001247)	Clip Finger Grip	8
21	42124	(000000–001247)	Plug, Drain	1
22	01570	(000000–001247)	Chain,#12Jack Type 6.0Lg	1
23	26395–2	(000000–001247)	Clamp–Cable, 0.38Dia 0.38Wth	1
24	76286	(000000–001247)	Adaptor Wldt, Vac Wand	1
25	76338	(000000–001247)	Bar, Prop	1
26	70659	(000000–001247)	Grip, Handle, Flat	2
27	76406	(000000–001247)	Label, Vac Wand	1

Fig. 35 – Vacuum Wand Kit

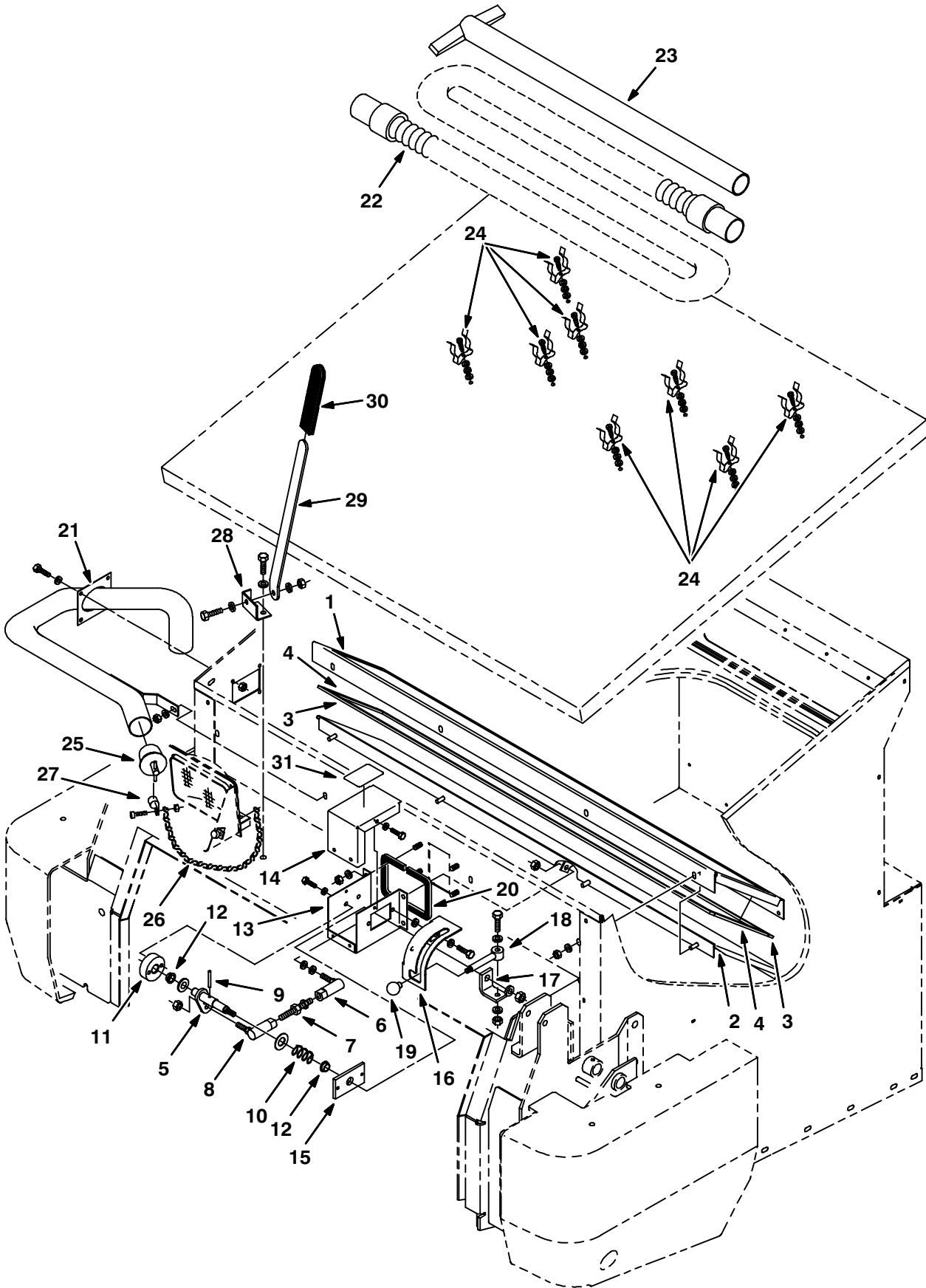

Fig. 35 – Vacuum Wand Kit

Ref.	Tennant Part No.	Machine Serial Number	Description	Qty.
∇	70668	(001248–) Wand Kit, Vac	1
1	73871	(001248–) Plate, Mounting, Vac Door	1
2	75701	(001248–) Plate Wldt, Vac Door	1
3	75876	(001248–) Seal, Foam Rbr, .19 .75W 47.1L	2
4	75877	(001248–) Seal, Foam Rbr .19 .75W 8.43L	2
5	21047	(001248–) Shaft	1
6	82962	(001248–) Balljoint .375–24 Lh	1
7	11676	(001248–) Stud, Adjustment	1
8	51531	(001248–) Ball Joint .375–24	1
9	23146	(001248–) Pin,Roll,.18Odx1.62L,.187/.192	1
10	19035	(001248–) Sprng,Comp,0.83Idx.07Wire 1.0L	1
11	21041	(001248–) Disk	1
12	04843	(001248–) Bearing, Flange .625 Bore	2
13	21054	(001248–) Box, Mounting, Lever, Vac	1
14	21104	(001248–) Panel, Cover	1
15	73880	(001248–) Plate	1
16	79646	(001248–) Plate, Latch	1
17	79647	(001248–) Angle	1
18	79644	(001248–) Handle	1
19	26565	(001248–) Knob,0.38–16,1.25Dia,Plastic	1
20	79674	(001248–) Seal	1
21	74074	(001248–) Adaptor Wldt, Vac Wand	1
22	54009	(001248–) Hose&2Cuff Assy,Vinyl2.0ld10Ft	1
23	54012	(001248–) Wand	1
24	36158	(001248–) Clip Finger Grip	8
25	42124	(001248–) Plug, Drain	1
26	01570	(001248–) Chain,#12Jack Type 6.0Lg	1
27	26395–2	(001248–) Clamp–Cable, 0.38Dia 0.38Wth	1
28	76286	(001248–) Adaptor Wldt, Vac Wand	1
29	76338	(001248–) Bar, Prop	1
30	70659	(001248–) Grip, Handle, Flat	2
31	76406	(001248–) Label, Vac Wand	1

Fig. 36 – Side Brush Dust Control Kit

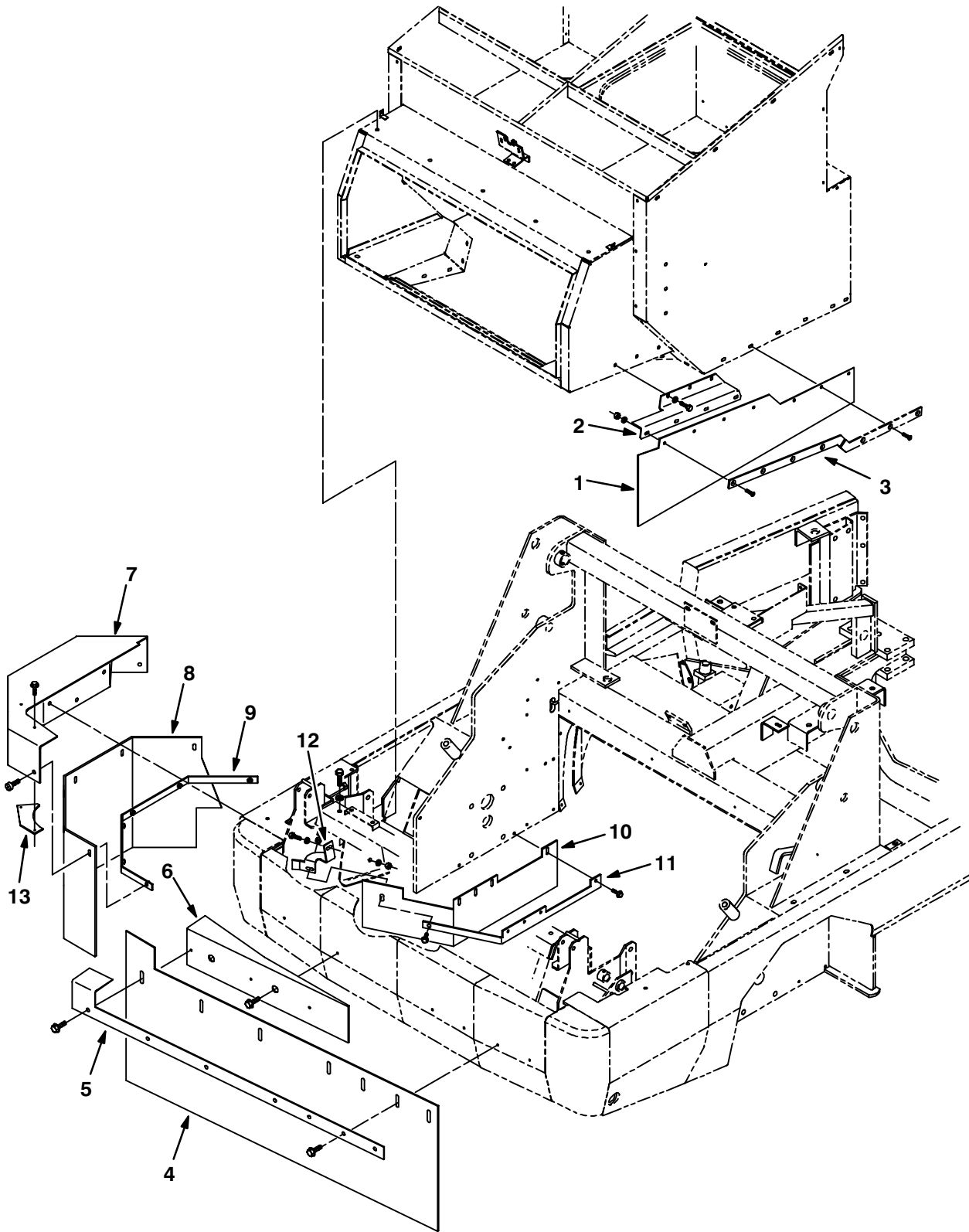

Fig. 36 – Side Brush Dust Control Kit

Ref.	Tenant Part No.	Machine Serial Number	Description	Qty.
∇	76100	(000000–)	Dust Control Kit, Side Brush	1
1	76036	(000000–)	Skirt, Deflection	1
2	76030	(000000–)	Bracket, Mounting, Skirt	1
3	76038	(000000–)	Strip, Retainer, Skirt	1
4	75901	(000000–)	Skirt, Cover, Sbdc	1
5	76049	(000000–)	Skirt, Retainer	1
6	77759	(000000–)	Bracket Wldt	1
7	75989	(000000–)	Plate Wldt, Skirt	1
8	76069	(000000–)	Skirt, Cover, Sbdc	1
9	76055	(000000–)	Plate, Retainer	1
10	76074	(000000–)	Skirt	1
11	76081	(000000–)	Skirt	1
12	76084	(000000–)	Bracket	1
13	77755	(000000–)	Plate	1

Fig. 37 – Air Cleaner Assembly, Gas SE

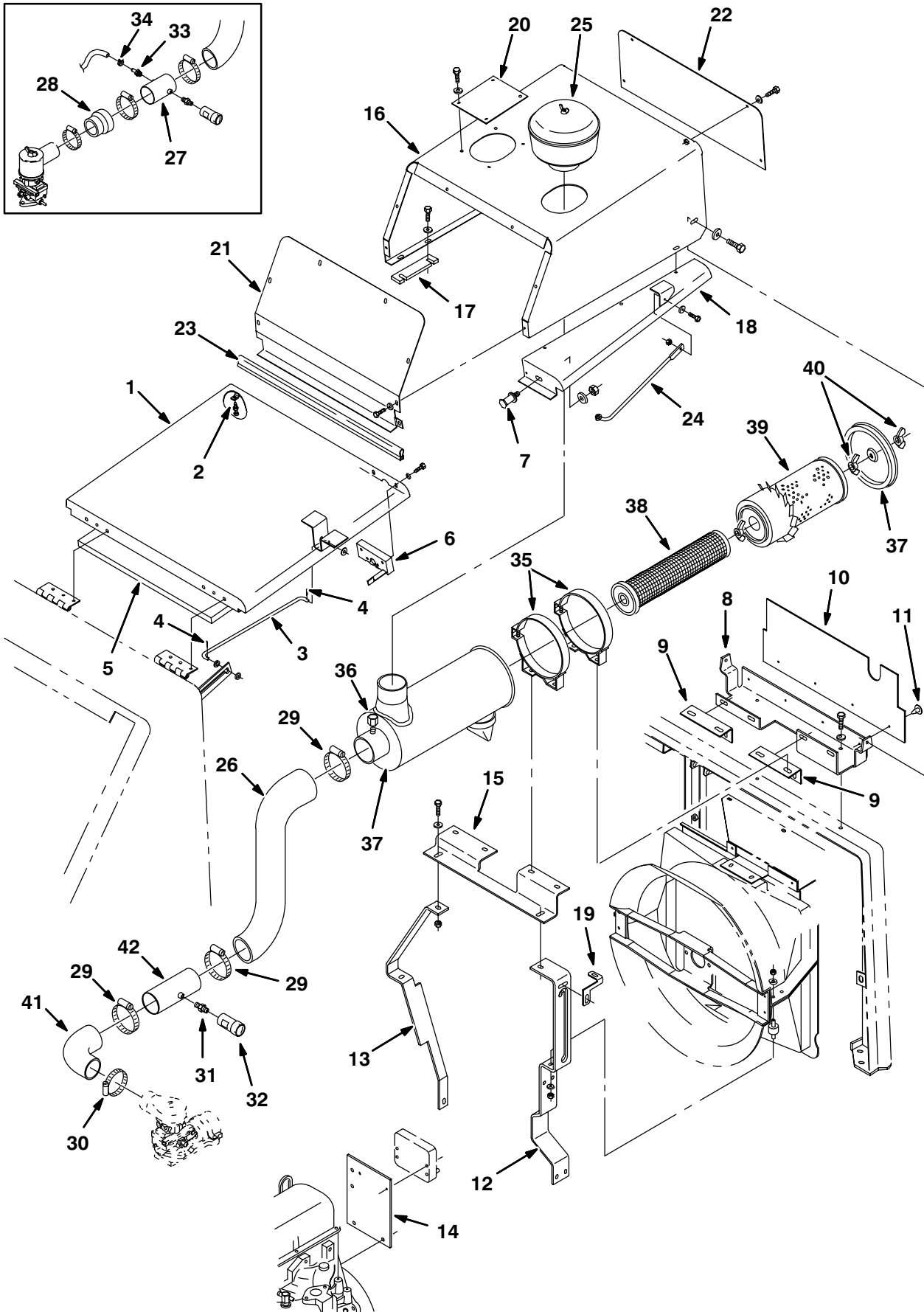

Fig. 37 – Air Cleaner Assembly, Gas SE

Ref.	Tennant Part No.	Machine Serial Number	Description	Qty.
1	75303	(000000–)	Cover Wldt, Engine Se	1
2	75128	(000000–)	Spindle, Adjustment	1
3	75883	(000000–)	Rod Support, Cover	1
4	39005	(000000–)	Pin– Cotter .094X0.75	2
5	76870	(000000–)	Insulation,S/Foam .8X19.3X20.3	1
6	58844	(000000–)	Latch, Hook, Lh	1
7	59192	(000000–)	Latch, Bolt	1
8	77703	(000000–)	Channel, Hinge, Filter Cover	1
9	79620	(000000–)	Bracket, Rear, Se	2
10	79626	(000000–)	Skirt, Air Cleaner, Se	1
11	72968	(000000–)	Rivet, Plastic .250X.898	4
12	77706	(000000–)	Bracket, Front, Lh	1
13	77707	(000000–)	Bracket, Front, Rh	1
14	83747	(001700–)	Bracket, Mtg, Ign Module	1
15	77704	(000000–)	Bracket, Mounting, Filter, Fro	1
16	77710	(000000–)	Panel, Cover, A/C Filter	1
17	21230	(000000–)	Plate, Support, Cover Se	1
18	77712	(000000–)	Panel Wldt, Cover	1
19	79624	(000000–)	Bracket	1
20	79625	(000000–)	Plate	1
21	77708	(000000–)	Panel, Cover, Front A/C	1
22	77489	(000000–)	Panel, Cover, Rear, A/C Filter	1
23	77778	(000000–)	Seal, Bulb, Sd–0504 19.75Lg	1
24	54615	(000000–)	Rod, Seat	1
25	75666	(000000–)	Filter, Pre–Cleaner, A/C	1
26	77787	(000000–)	Hose, Molded, Se, Gas	1
27	77786	(000000–001699)	Tube, Intake, Se, Gas	1
28	51745	(000000–001699)	Adaptor, Molded 2.50B	1
29	43555	(000000–)	Clamp–Wormdrive, 1.62– 3.50D	3
30	22297	(000000–)	Clamp–Wormdrive, 1.56– 2.50D L	1
31	51560–5	(000000–)	Adaptor, Filter, 1/8 Npt	1
32	03026	(000000–)	Indicator Service Air Filter	1
33	27768	(000000–001699)	Fitting, Brass Em06/Pm02	1
34	43844	(000000–001699)	Clamp–Wormdrive, 0.25– 0.62D	1
35	76321	(000000–)	Band,Mtg.	2
36	60745	(000000–)	Ftg Cap Npt 02Pf	1
∇ 37	35424	(000000–)	Air Cleaner	1
38	60933	(000000–)	Element, Filter Safety	1
39	60934	(000000–)	Element, Air Cleaner	1
40	07562	(000000–)	Nut,Wing .44–20 Special	2
41	83646	(001700–)	Elbow, Rubber 90 2.5 Id x 2.0 Id	1
42	70836	(001700–)	Tube Wldt, Air Cleaner	1

Fig. 38 – Air Cleaner Assembly, LPG SE

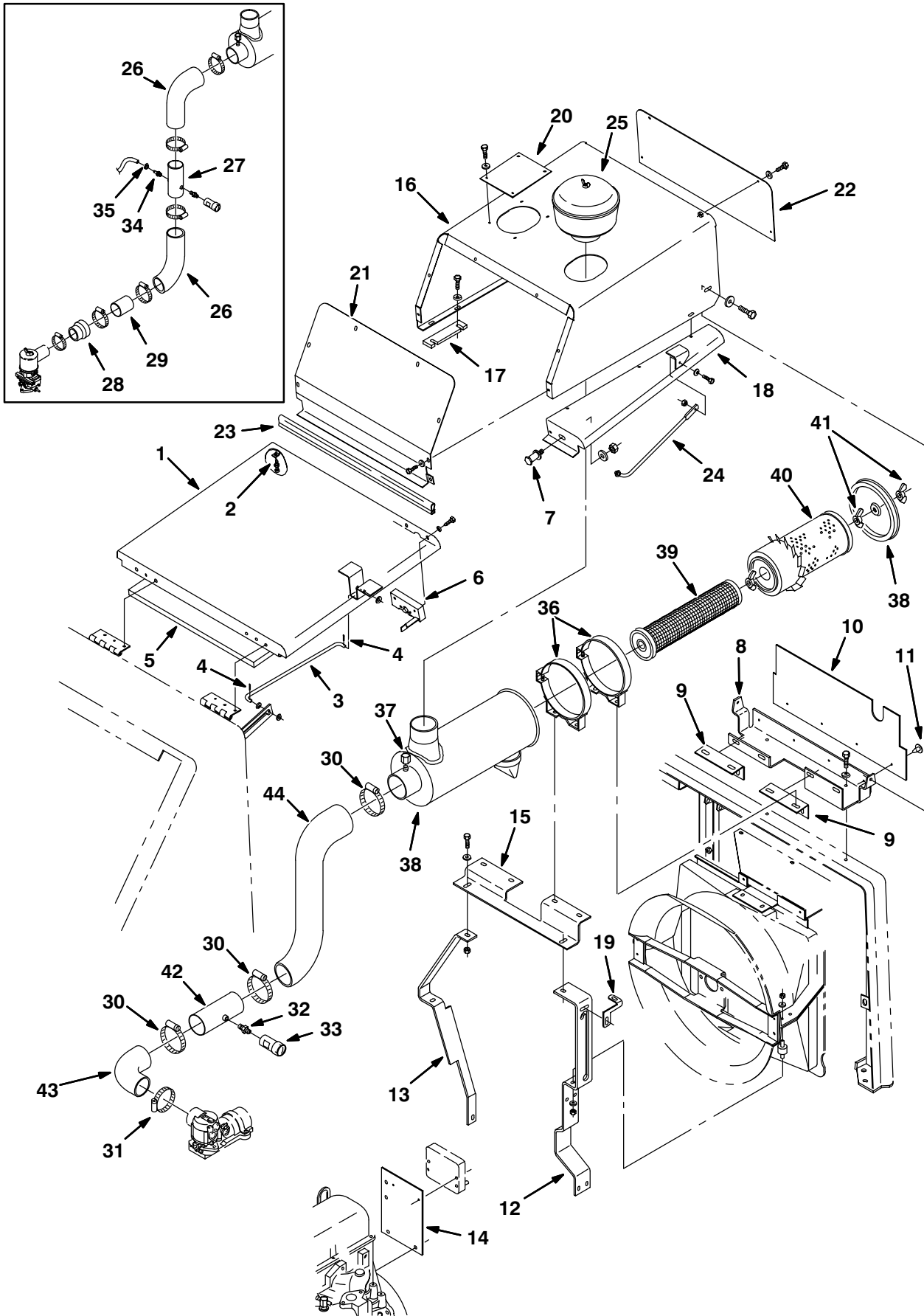
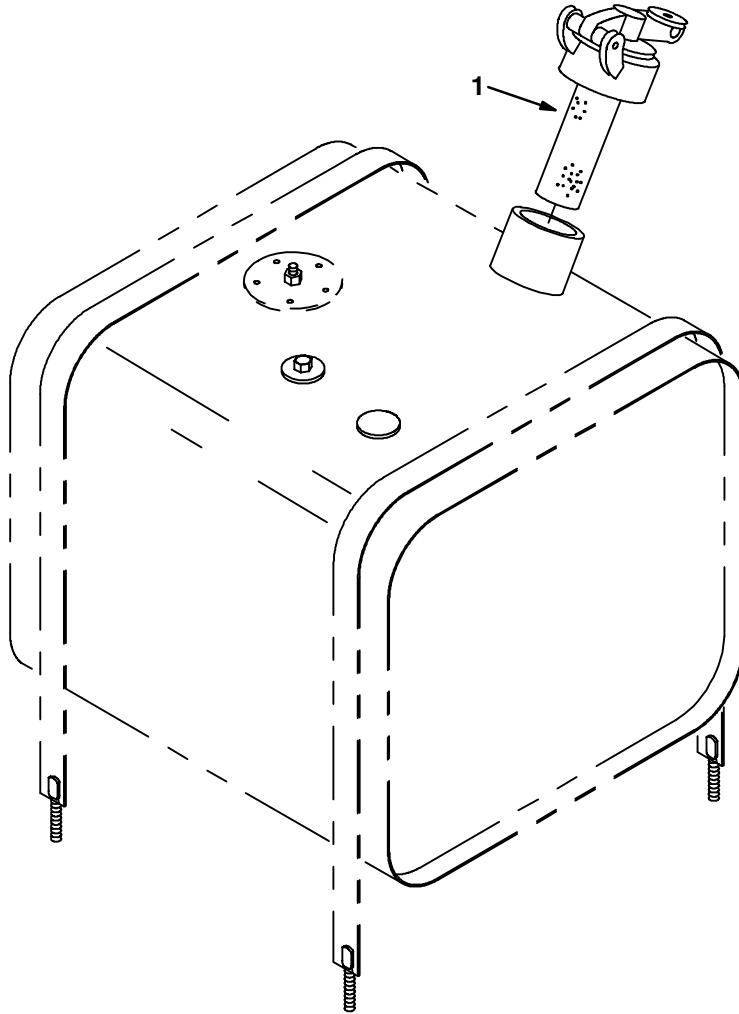

Fig. 38 – Air Cleaner Assembly, LPG SE

Ref.	Tennant Part No.	Machine Serial Number	Description	Qty.
1	75303	(000000–)	Cover Wldt, Engine Se	1
2	75128	(000000–)	Spindle, Adjustment	1
3	75883	(000000–)	Rod Support, Cover	1
4	39005	(000000–)	Pin– Cotter .094X0.75	2
5	76870	(000000–)	Insulation,S/Foam .8X19.3X20.3	1
6	58844	(000000–)	Latch, Hook, Lh	1
7	59192	(000000–)	Latch, Bolt	1
8	77703	(000000–)	Channel, Hinge, Filter Cover	1
9	79620	(000000–)	Bracket, Rear, Se	2
10	79626	(000000–)	Skirt, Air Cleaner, Se	1
11	72968	(000000–)	Rivet, Plastic .250X.898	4
12	77706	(000000–)	Bracket, Front, Lh	1
13	77707	(000000–)	Bracket, Front, Rh	1
14	83747	(001700–)	Bracket, Mtg, Ign Module	1
15	77704	(000000–)	Bracket, Mounting, Filter, Fro	1
16	77710	(000000–)	Panel, Cover, A/C Filter	1
17	21230	(000000–)	Plate, Support, Cover Se	1
18	77712	(000000–)	Panel Wldt, Cover	1
19	79624	(000000–)	Bracket	1
20	79625	(000000–)	Plate	1
21	77708	(000000–)	Panel, Cover, Front A/C	1
22	77489	(000000–)	Panel, Cover, Rear, A/C Filter	1
23	77778	(000000–)	Seal, Bulb, Sd–0504 19.75Lg	1
24	54615	(000000–)	Rod, Seat	1
25	75666	(000000–)	Filter, Pre–Cleaner, A/C	1
26	77787	(000000–001699)	Hose, Molded, Se, Gas (Cut in half)	1
27	75519	(000000–001699)	Tube, Intake, Gas	1
28	51745	(000000–001699)	Adaptor, Molded 2.50B	1
29	70838	(000000–001699)	Tube, Air Cleaner	1
30	43555	(000000–)	Clamp–Wormdrive, 1.62– 3.50D	3
31	22297	(000000–)	Clamp–Wormdrive, 1.56– 2.50D L	1
32	51560–5	(000000–)	Adaptor, Filter, 1/8 Npt	1
33	03026	(000000–)	Indicator Service Air Filter	1
34	27768	(000000–001699)	Fitting, Brass Em06/Pm02	1
35	43844	(000000–001699)	Clamp–Wormdrive, 0.25– 0.62D	1
36	76321	(000000–)	Band,Mtg.	2
37	60745	(000000–)	Ftg Cap Npt 02Pf	1
∇ 38	35424	(000000–)	Air Cleaner	1
39	60933	(000000–)	Element, Filter Safety	1
40	60934	(000000–)	Element, Air Cleaner	1
41	07562	(000000–)	Nut,Wing .44–20 Special	2
42	70836	(001700–)	Tube Wldt, Air Cleaner	1
43	83646	(001700–)	Elbow, Rubber 90 2.5 Id x 2.0 Id	1
44	77787	(001700–)	Hose, Molded, Se, Gas	1

Fig. 39 – Protectoseal Fuel Tank Cap Group



07867/07471

Ref.	Tennant Part No.	Machine Serial Number	Description	Qty.
1	02506-6	(00000-)	Gas Cap, Protectoseal	1

Fig. 40 – Fire Extinguisher Kit

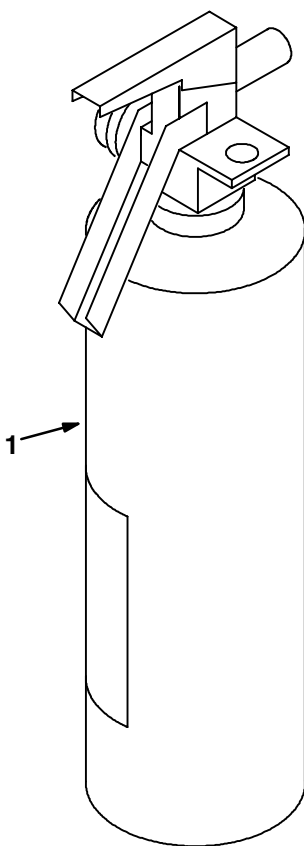

07687/07516

Ref.	Tennant Part No.	Machine Serial Number	Description	Qty.
∇	70692	(000000–) Extinguisher Kit Fire 800	1
1	25312	(000000–) Extinguisher, Fire	

Fig. 41 – Solid Tire and Rim Assembly, Front

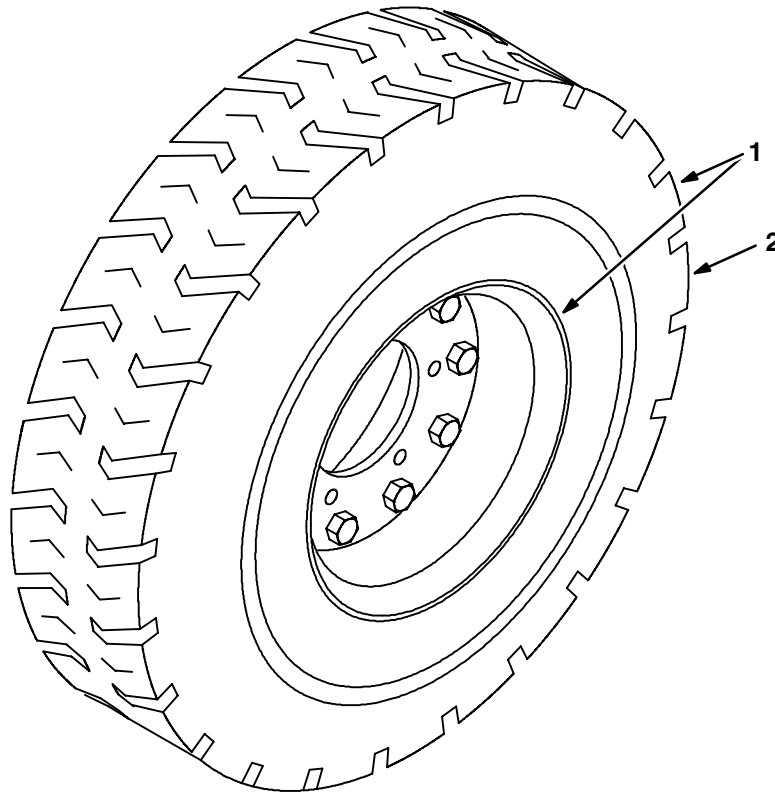

07665/07666

Ref.	Tennant Part No.	Machine Serial Number	Description	Qty.
∇ 1	63226	(000000–) Tire and Rim Assembly, Solid 6.50–10	1
2	63228	(000000–) Tire, Solid	1

Fig. 42 – Solid Tire and Rim Assembly, Rear

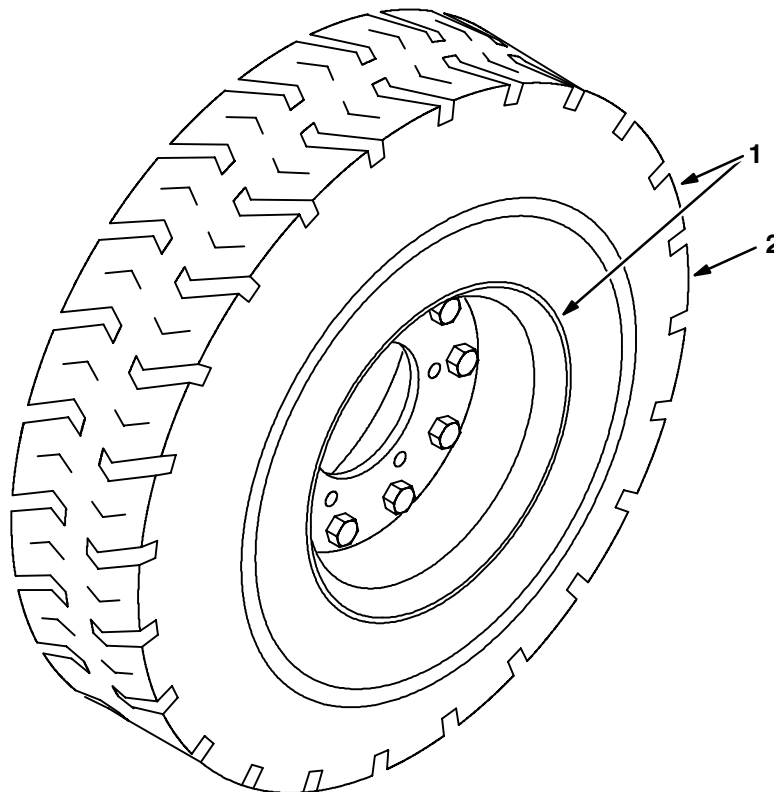

10504/07666

Ref.	Tennant Part No.	Machine Serial Number	Description	Qty.
∇ 1	21671	(000000–) Tire and Rim Assy, Rear, Solid 6.5	1
2	63228	(000000–) Tire, Solid	1

Fig. 43 – Seat Belt Kit

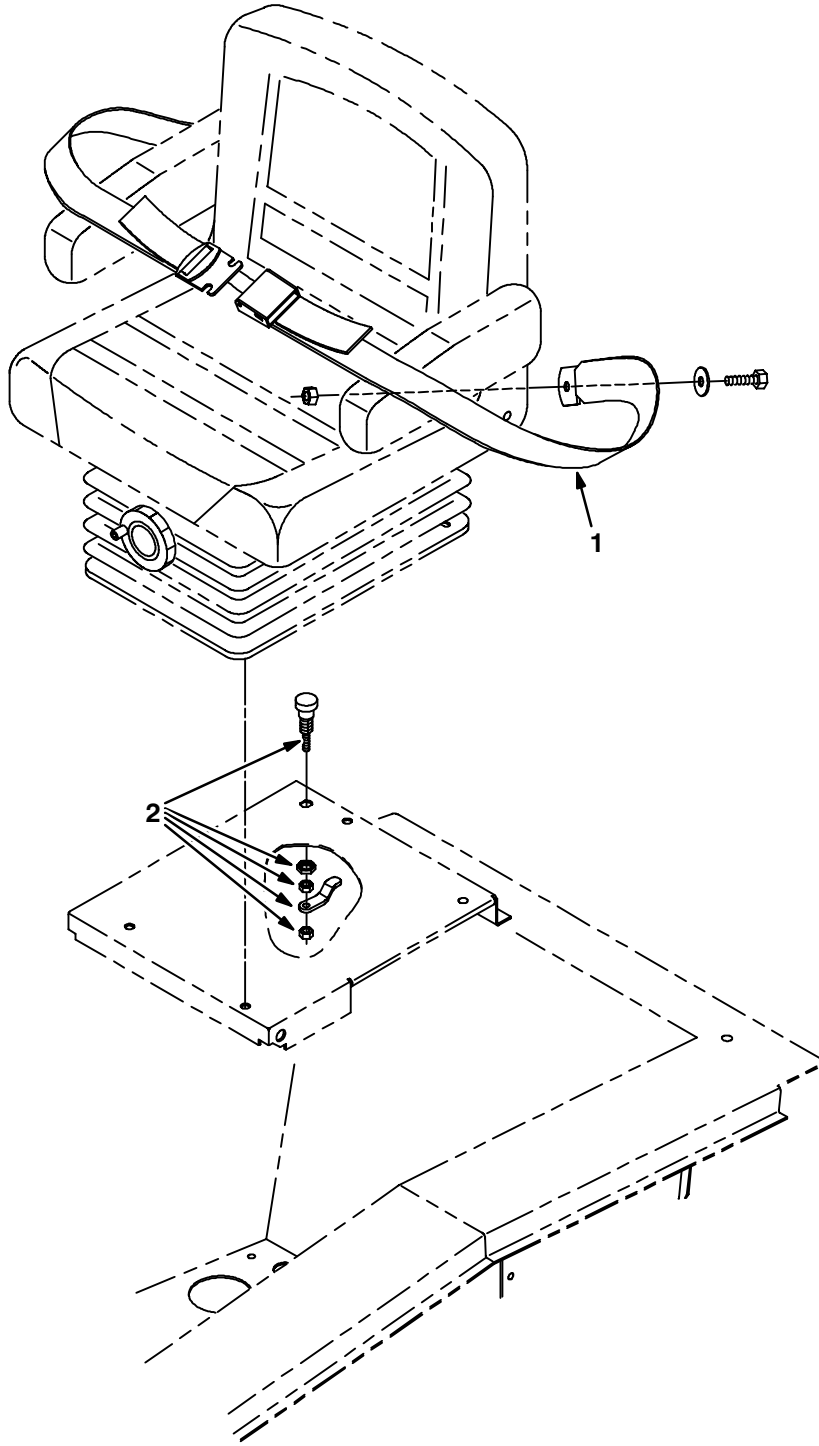

07673/07674

Ref.	Tennant Part No.	Machine Serial Number	Description	Qty.
∇	70690	(000000–)	Seat Belt Kit	1
1	30533	(000000–)	Belt, Seat	1
2	87337	(000000–)	Latch, Door	1

Fig. 44 – Neutral Start Group

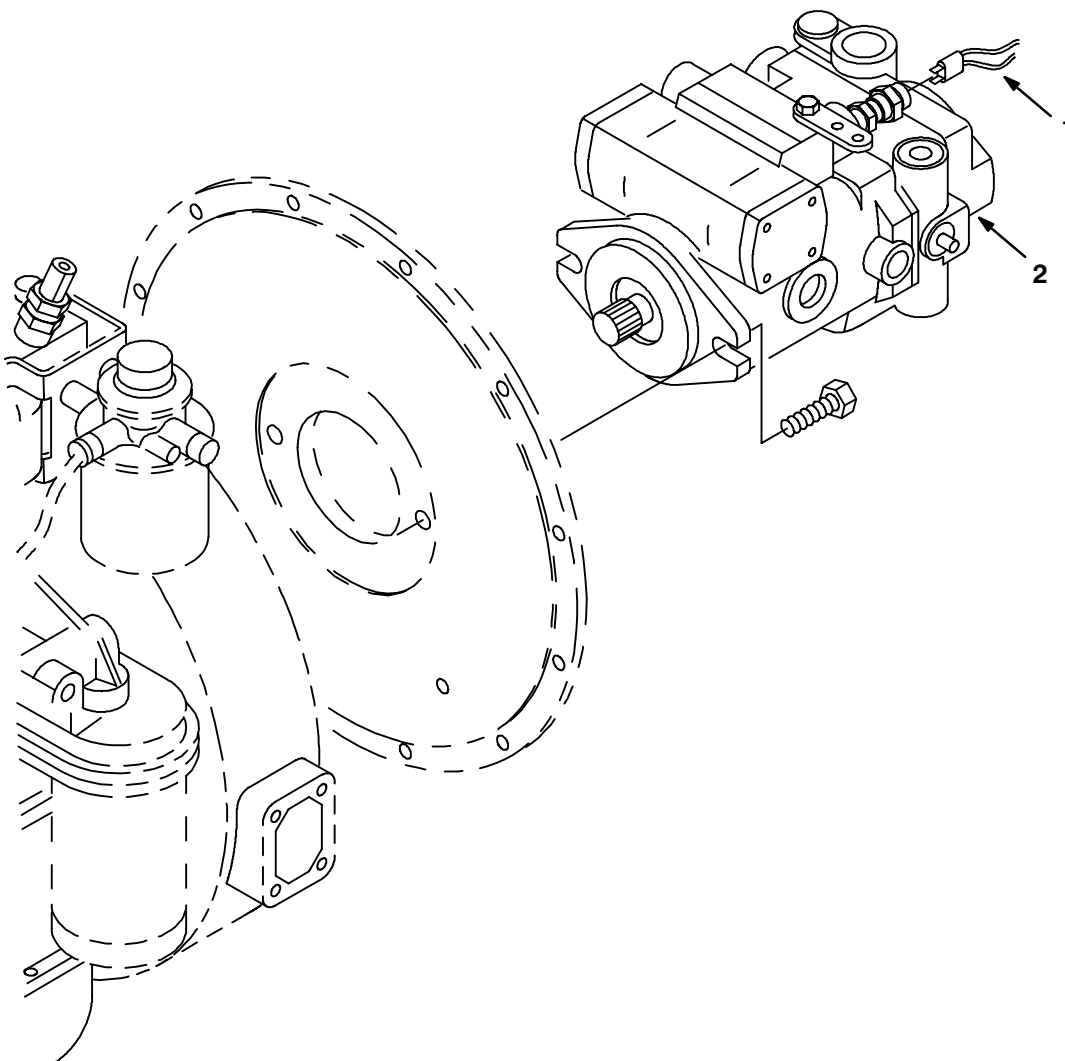

09830/09831

Ref.	Tennant Part No.	Machine Serial Number	Description	Qty.
1	63407	(000000–) Harness, Neutral, Start	1
2	74164	(000000–) Pump, Hyd Piston V 2.48 (see breakdowns)	1

Fig. 45 – RFS Filter System Group

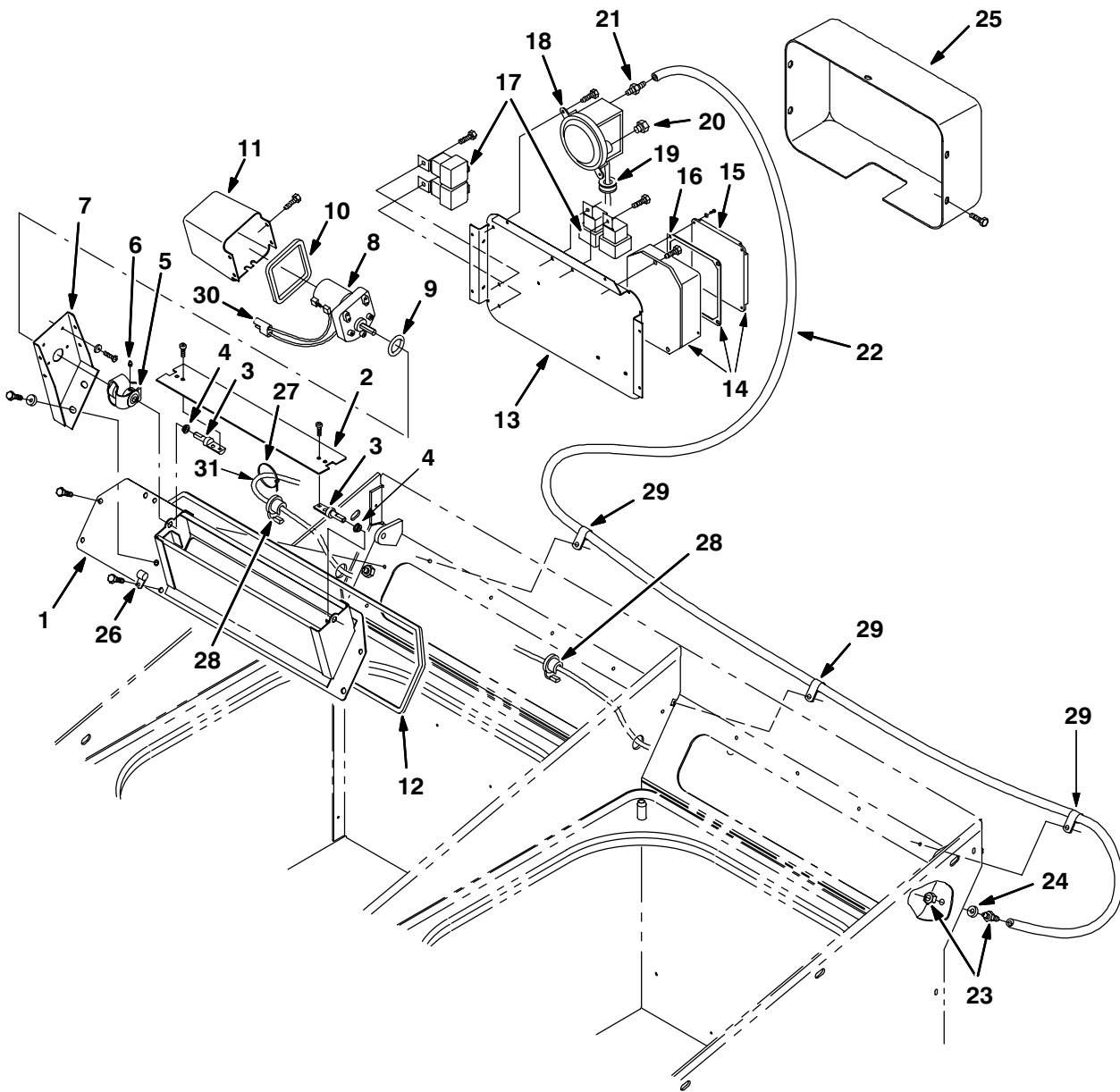
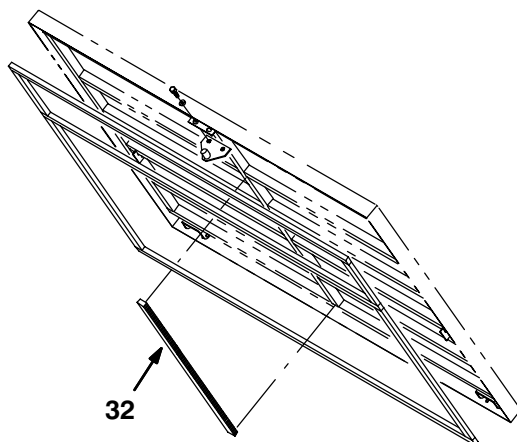

Fig. 45 – RFS Filter System Group



10230/10229,10232

Ref.	Tennant Part No.	Machine Serial Number	Description	Qty.	
▽	79174	(000000–) Rfs Kit	1	
1	79160	(000000–) Duct Wldt, Rfs	2	
2	79156	(000000–) Plate, Shutter	2	
3	79159	(000000–) Shaft, Pivot	4	
4	11747	(000000–) Bearing, Nylon	4	
5	79158	(000000–) Coupling	2	
6	20634	(000000–) Scr-Set 10–24X0.25 Nylon Loc	4	
7	79157	(000000–) Bracket, Mounting, Gearmotor	2	
8	79170	(000000–) Motor, Ele, Geared, 12Vdc	2	
9	79172	(000000–) Seal, O-Ring .787Idx.210Th	2	
10	79167	(000000–) Seal	2	
11	79155	(000000–) Cover, Motor	2	
12	79168	(000000–) Seal	2	
13	79177	(000000–) Plate, Mounting, Rfs Control	1	
▽	14	79176	(000000–) Controller Assy, Rfs	1
15	59954	(000000–) Cover, Housing, Electrical	1	
16	59921	(000000–) Gasket, Cover, Alum	1	
17	56186	(000000–) Relay, Shrouded, 12 Vdc	4	
18	75465	(000000–) Switch, Pressure	1	
19	10632–4	(000000–) Grommet,Rbr,0.62Id,For .06Matl	1	
20	82739	(000000–) Ftg, Breather	1	
21	40607	(000000–) Ftg,Brass,St Bm03/Pm02	1	
22	21301	(000000–) Hose, Vacuum, .16 Id X 76.0 Lg	1	
23	39923	(000000–) Ftg,Bulkhead–Barb Wh 1074X4	1	
24	43454	(000000–) Washer, .344B .69D .06Nylon	1	
25	79169	(000000–) Cover, Electrical	1	
26	40678	(000000–) Clamp,Cable .44D .62Wide	2	
27	49266	(000000–) Tie, Cable 1.75D Max 7.50Lg	12	
28	34864	(000000–) Strain,Relief	2	
29	46236	(000000–) Clamp–Cable, 0.25Dia 0.56Wth	3	
30	79025	(000000–) Harness, Motor, Duct	2	
31	79026	(000000–) Harness, Hopper, Rfs	1	
	83706	(000000–) Harness, Rfs Jumper	1	
32	70851	(000000–) Seal, Urethane	1	
	44961	(000000–) Tie, Cable 4.00 Max 14.50Lg	14	

Fig. 46 – Documentation Group

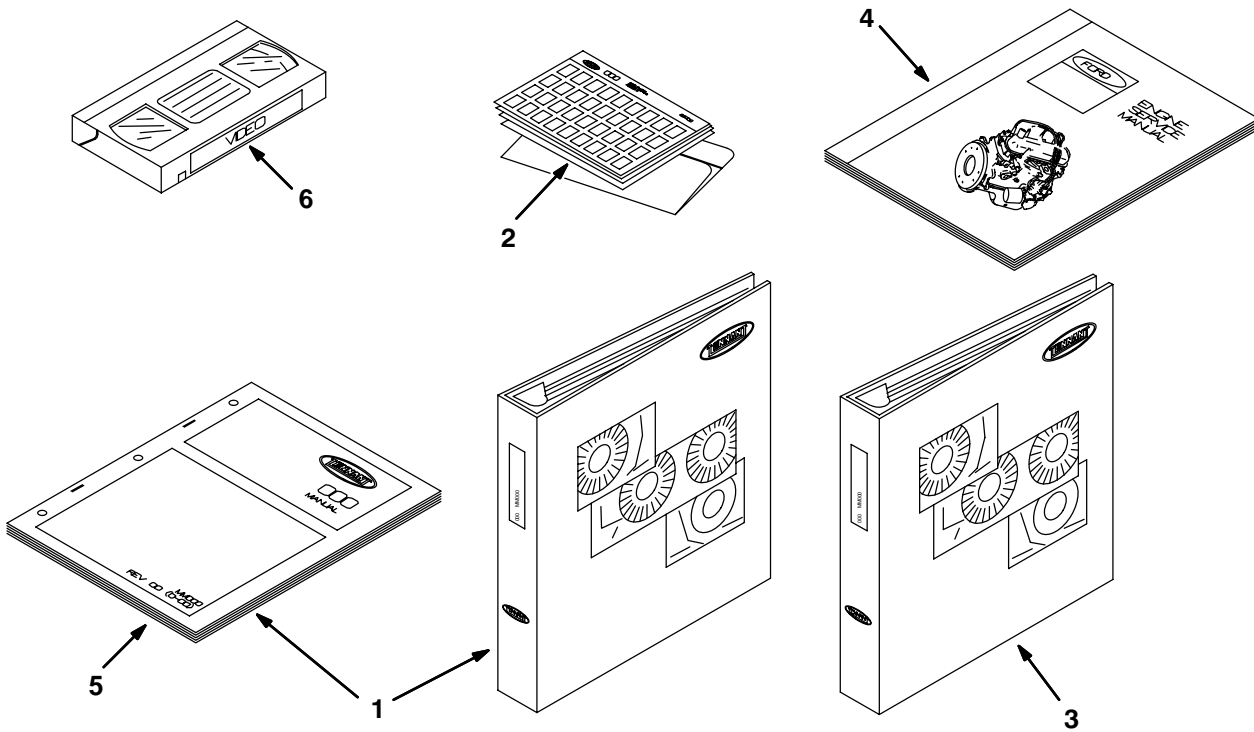

07679/07501

Ref.	Tennant Part No.	Machine Serial Number	Description	Qty.
1	MM307	(000000–)	Manual Pkg 800	1
2	85307	(000000–)	Manual–Fiche Pkg 800	1
3	MM337	(000000–)	Manual, Service 800/810	1
4	61875	(000000–)	Service Manual FD 2.3 Liter - LSG-423	1
5	MM307ES	(000000–)	Manual Op/Mt 800 Spanish	1
5	MM307FR	(000000–)	Manual Op/Mt 800 French	1
6	48842	(000000–)	Oper/Video Vhs, 800	1

SECTION 4

CONTENTS

	PAGE
Fig. 1 – Hydraulic Piston Pump Breakdown, 62548	4-2
Fig. 2 – Hydraulic Piston Pump Breakdown, 62548	4-4
Fig. 3 – Hydraulic Piston Pump Breakdown, 74163	4-6
Fig. 4 – Hydraulic Piston Pump Breakdown, 74163	4-8
Fig. 5 – Hydraulic Piston Pump Breakdown, 65219	4-10
Fig. 6 – Hydraulic Piston Pump Breakdown, 65219	4-12
Fig. 7 – Hydraulic Piston Pump Breakdown, 74164	4-14
Fig. 8 – Hydraulic Piston Pump Breakdown, 74164	4-16
Fig. 9 – Hydraulic Gear Pump Breakdown, 62561	4-18
Fig. 10 – Hydraulic Motor Breakdown, 63426	4-19
Fig. 11 – Hydraulic Motor Breakdown, 53434	4-20
Fig. 12 – Hydraulic Motor Breakdown, 62564	4-21
Fig. 13 – Hydraulic Motor Breakdown, 79781	4-22
Fig. 14 – Hydraulic Motor Breakdown, 19117	4-23
Fig. 15 – Hydraulic Motor Breakdown, 63542	4-24
Fig. 16 – Hydraulic Steering Valve Breakdown, 62565	4-25
Fig. 17 – Hydraulic Steering Valve Breakdown, 65242	4-26
Fig. 18 – Hydraulic Solenoid Valve Breakdown, 65391	4-27
Fig. 19 – Hydraulic Solenoid Valve Breakdown, 84015	4-28
Fig. 20 – Hydraulic Solenoid Valve Breakdown, 84016	4-29
Fig. 21 – Hydraulic Solenoid Valve Breakdown, 63527	4-30
Fig. 22 – Hydraulic Solenoid Valve Breakdown, 78996	4-32
Fig. 23 – Hydraulic Solenoid Valve Breakdown, 84014	4-34
Fig. 24 – Hydraulic Valve Breakdown, 62567	4-36
Fig. 25 – Hydraulic Valve Breakdown, 77495	4-37
Fig. 26 – Hydraulic Manual Control Breakdown, 74285	4-38
Fig. 27 – Hydraulic Manual Control Breakdown, 74273	4-40
Fig. 28 – Hydraulic Cylinder Breakdown, 53601	4-42
Fig. 29 – Hydraulic Cylinder Breakdown, 62975	4-43
Fig. 30 – Air Conditioner Breakdown, 77675	4-44
Fig. 31 – Air Conditioner Breakdown, 21270	4-46
Fig. 32 – Heater/Pressurizer Breakdown, 74091	4-48
Fig. 33 – Heater/Pressurizer Breakdown, 21271	4-50

Fig. 1 – Hydraulic Piston Pump Breakdown, 62548

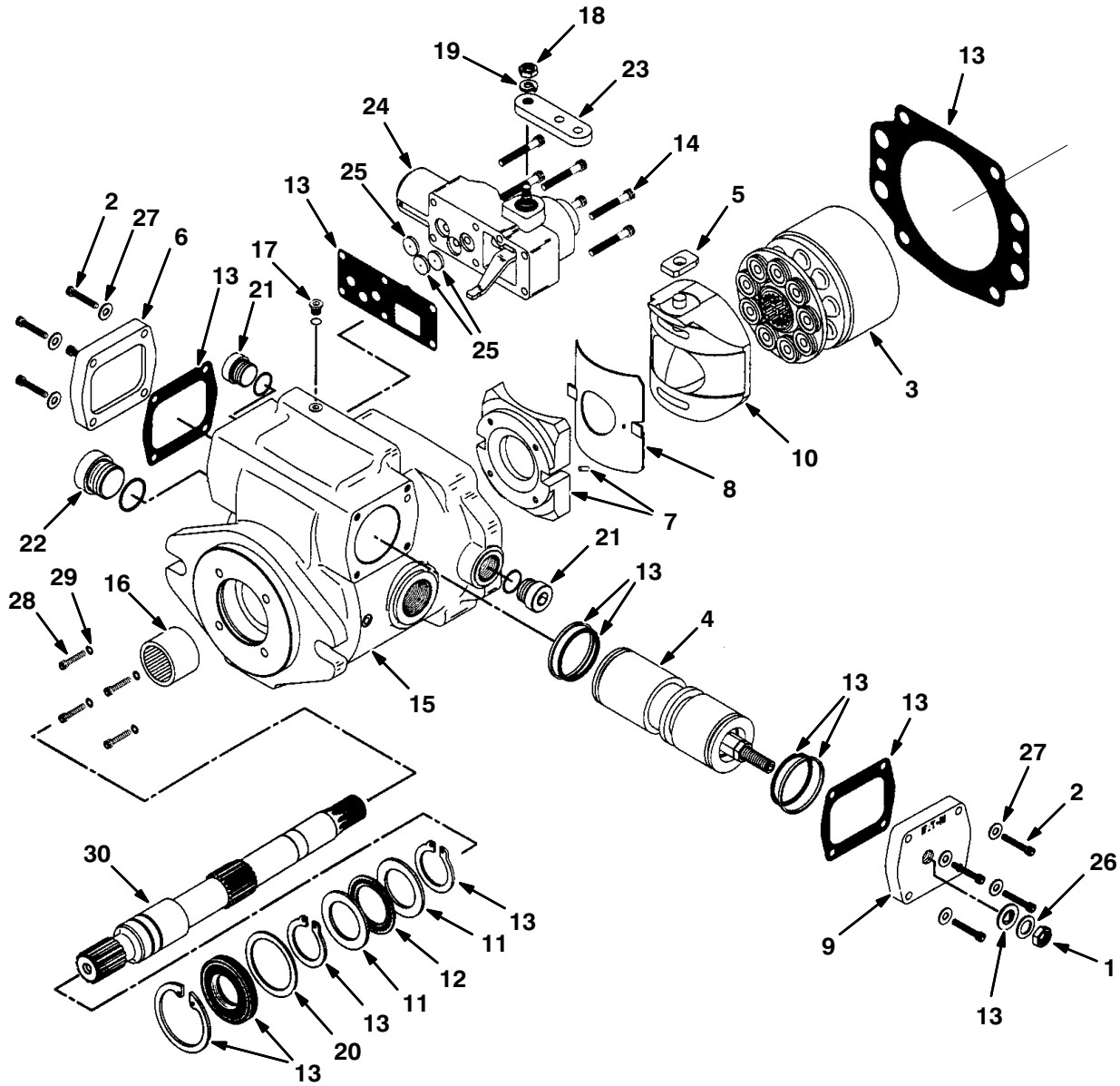

Fig. 1 – Hydraulic Piston Pump Breakdown, 62548

Ref.	Tennant Part No.	Machine Serial Number	Description	Qty.	
∇	62548	(000000–) Pump–Hyd Piston V 2.48 R4500	1	
1	74184	(000000–) Nut, Jam	1	
2	74223	(000000–) Screw, Cap	8	
3	61882	(000000–) Rotating Kit	1	
4	74286	(000000–) Servo Piston Sa En	1	
5	74287	(000000–) Follower,Piston En	1	
6	74256	(000000–) Plate, Cover En	1	
7	74288	(000000–) Camplate Cradle En	1	
8	74289	(000000–) Cam Bushing En	1	
9	74257	(000000–) Plate, Cover En	1	
10	74224	(000000–) Camplate S/A En	1	
11	74240	(000000–) Race, Bearing Ce	2	
12	74210	(000000–) Bearing	1	
13	79709	(000000–) Seal Kit, Pump En	1	
14	74262	(000000–) Screw, Cap En	6	
∇	15	79703	(000000–) Housing S/A En	1
16	37462	(000000–) Bearing	1	
17	79742	(000000–) Plug S/A En	1	
18	74266	(000000–) Nut En	1	
19	74267	(000000–) Lockwasher En	1	
20	37460	(000000–) Washer	1	
21	13907	(000000–) Plug #8	2	
22	79779	(000000–) Plug,#12 O–Ring Ph	1	
23	74272	(000000–) Arm, Control En	1	
24	74273	(000000–) Control, Manual (see Breakdown)	1	
25	74276	(000000–) Orifice, Valve En	3	
26	74280	(000000–) Washer En	1	
27	74281	(000000–) Washer En	8	
28	79706	(000000–) Screw, Cap En	4	
29	79707	(000000–) Washer En	4	
30	74265	(000000–) Shaft, Drive Sp En	1	

NOTE: Piston Pump, TENNANT Part Number 62548, includes Fig. 1, and Fig. 2.

Fig. 2 – Hydraulic Piston Pump Breakdown, 62548

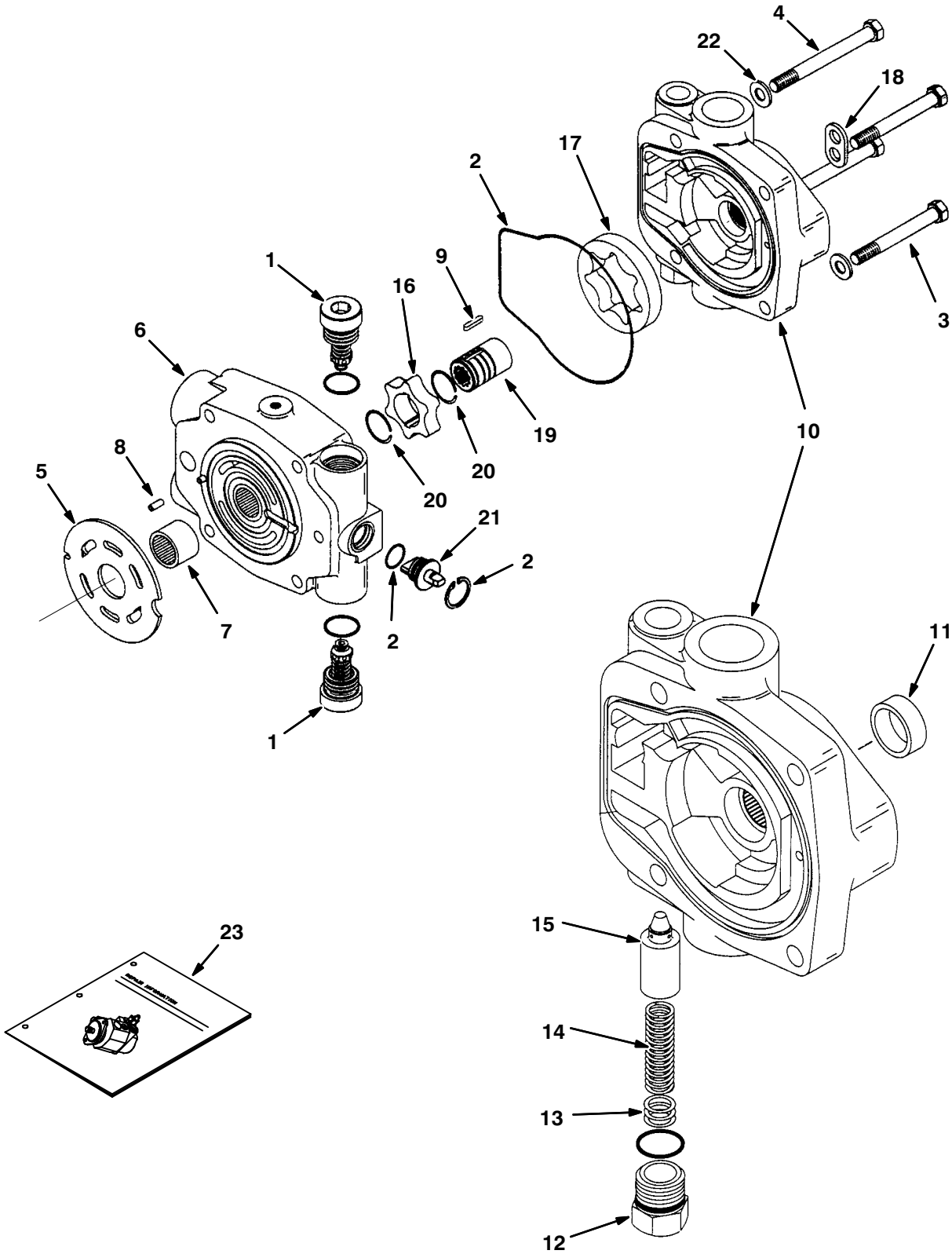

Fig. 2 – Hydraulic Piston Pump Breakdown, 62548

Ref.	Tennant Part No.	Machine Serial Number	Description	Qty.	
∇	62548	(000000–) Pump–Hyd Piston V 2.48 R4500	1	
1	74259	(000000–) Relief Valve Sa En	2	
2	79709	(000000–) Seal Kit, Pump En	1	
3	74260	(000000–) Screw, Cap En	2	
4	74261	(000000–) Screw, Cap En	2	
5	61886	(000000–) Valve Plate	1	
∇	6	79704	(000000–) Backplate S/A En	1
7	34159	(000000–) Bearing	1	
8	79748	(000000–) Roll Pin En	1	
9	74270	(000000–) Key En	1	
∇	10	74271	(000000–) Charge Pmp Adap En	1
11	79749	(000000–) Bushing En	1	
12	79750	(000000–) Plug En	1	
13	79751	(000000–) Shims En	1	
14	79752	(000000–) Spring En	1	
15	79753	(000000–) Poppet En	1	
16	74274	(000000–) Geroter,Ring In En	1	
17	74275	(000000–) Geroter,Ring Ot En	1	
18	79705	(000000–) Strap, Shipping En	1	
19	74277	(000000–) Coupler En	1	
20	74278	(000000–) Ring, Retaining En	2	
21	74279	(000000–) Actuator, Valve En	1	
22	74282	(000000–) Washer En	4	
23	74284	(000000–) Repair Info,Pmp En	1	

NOTE: Piston Pump, TENNANT Part Number 62548, includes Fig. 1, and Fig. 2.

Fig. 3 – Hydraulic Piston Pump Breakdown, 74163

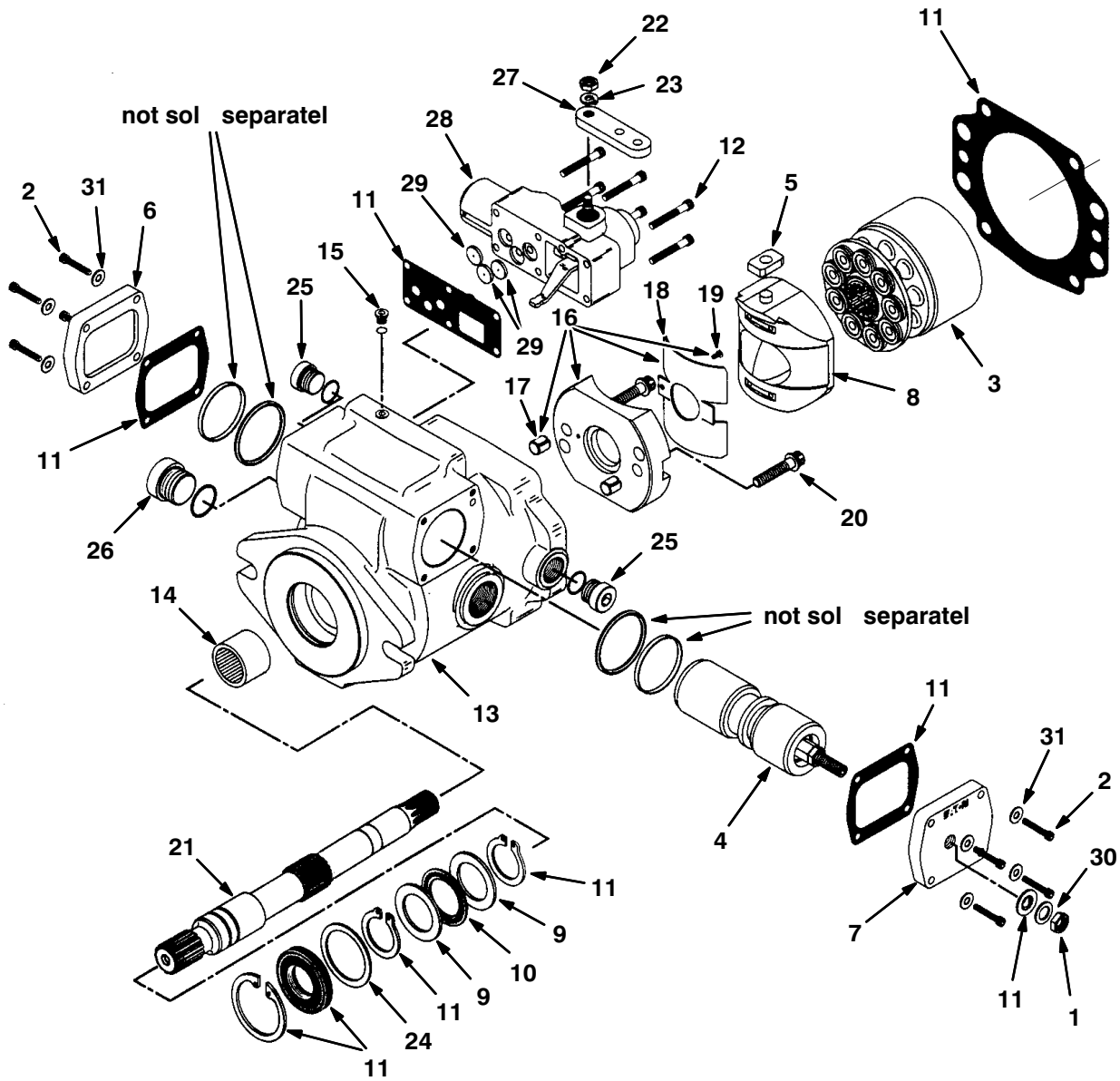

Fig. 3 – Hydraulic Piston Pump Breakdown, 74163

Ref.	Tennant Part No.	Machine Serial Number	Description	Qty.	
▽	74163	(000000–)	Pump, Hyd Piston V 2.48 R4500	1	
1	74184	(000000–)	Nut, Jam	1	
2	74223	(000000–)	Screw, Cap	8	
3	61882	(000000–)	Rotating Kit	1	
4	74253	(000000–)	Piston, Servo	1	
5	74254	(000000–)	Follower, Piston	1	
6	74256	(000000–)	Plate, Cover En	1	
7	74257	(000000–)	Plate, Cover En	1	
8	74258	(000000–)	Camplate S/A En	1	
9	74240	(000000–)	Race, Bearing Ce	2	
10	74210	(000000–)	Bearing	1	
11	74283	(000000–)	Seal Kit, Pump En	1	
12	74262	(000000–)	Screw, Cap En	6	
▽	74263	(000000–)	Housing S/A En	1	
13	79771	(000000–)	Housing En	1	
14	37462	(000000–)	Bearing	1	
15	79742	(000000–)	Plug S/A En	1	
▽	16	79743	(000000–)	Cradle Sub Assy En	1
17	79744	(000000–)	Dowel Bushing En	2	
18	79745	(000000–)	Bushing En	1	
19	79746	(000000–)	Cap Screw En	1	
20	79747	(000000–)	Cap Screw En	2	
21	74265	(000000–)	Shaft, Drive Sp En	1	
22	74266	(000000–)	Nut En	1	
23	74267	(000000–)	Lockwasher En	1	
24	37460	(000000–)	Washer	1	
25	13907	(000000–)	Plug #8	2	
26	79779	(000000–)	Plug,#12 O–Ring Ph	1	
27	74272	(000000–)	Arm, Control En	1	
28	74273	(000000–)	Control, Manual (see Breakdown)	1	
29	74276	(000000–)	Orifice, Valve En	1	
30	74280	(000000–)	Washer En	1	
31	74281	(000000–)	Washer En	8	

NOTE: Piston Pump, TENNANT Part Number 74163, includes Fig. 3, and Fig. 4.

Fig. 4 – Hydraulic Piston Pump Breakdown, 74163

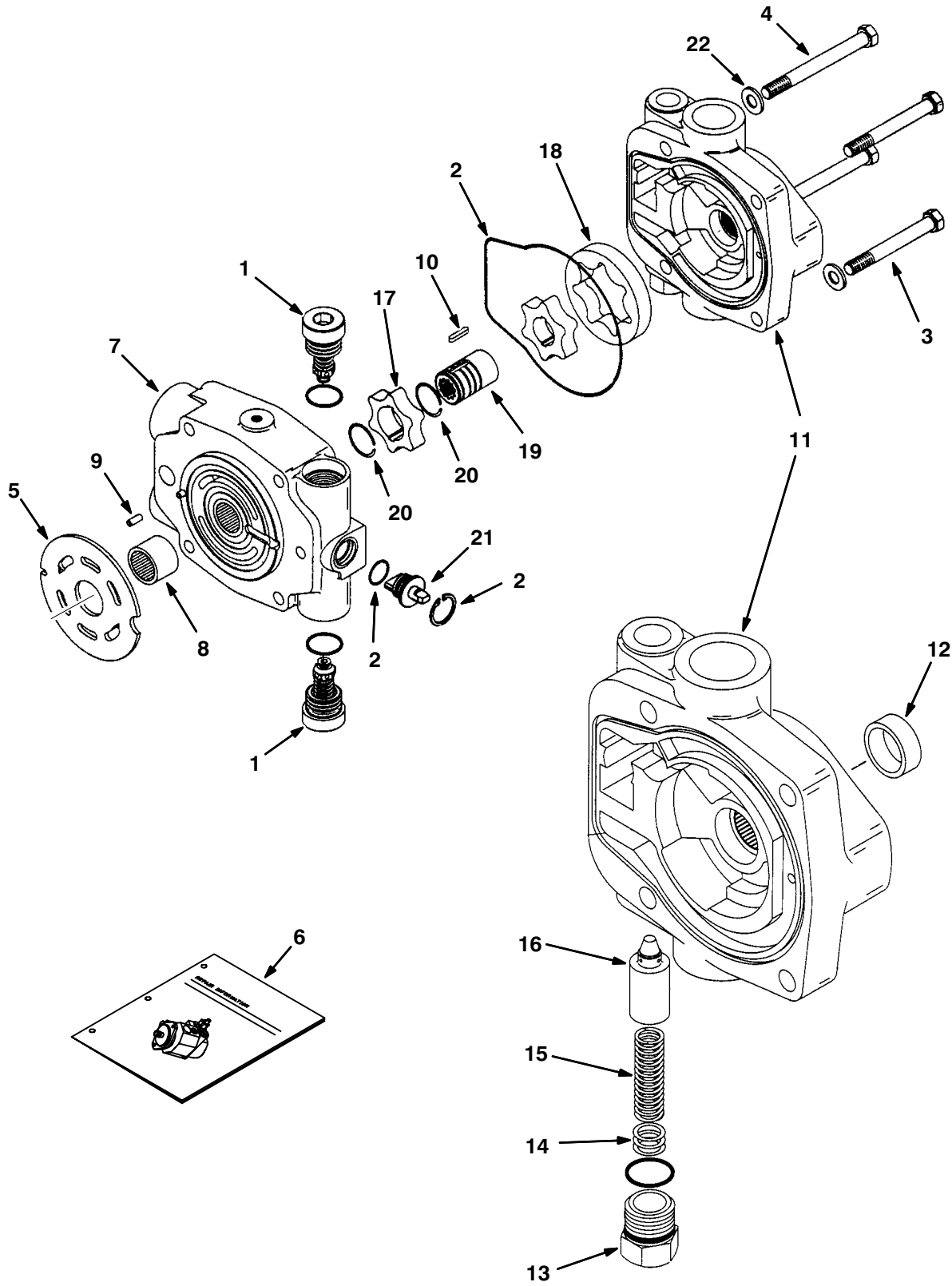

Fig. 4 – Hydraulic Piston Pump Breakdown, 74163

Ref.	Tennant Part No.	Machine Serial Number	Description	Qty.	
∇	74163	(000000–) Pump, Hyd Piston V 2.48 R4500	1	
1	74259	(000000–) Relief Valve Sa En	2	
2	74283	(000000–) Seal Kit, Pump En	1	
3	74260	(000000–) Screw, Cap En	2	
4	74261	(000000–) Screw, Cap En	2	
5	61886	(000000–) Valve Plate	1	
6	79708	(000000–) Repair Info,Pmp En	1	
∇	7	74264	(000000–) Backplate S/A En	1
8	34159	(000000–) Bearing	1	
9	79748	(000000–) Roll Pin En	1	
10	74270	(000000–) Key En	1	
∇	11	74271	(000000–) Charge Pmp Adap En	1
12	79749	(000000–) Bushing En	1	
13	79750	(000000–) Plug En	1	
14	79751	(000000–) Shims En	1	
15	79752	(000000–) Spring En	1	
16	79753	(000000–) Poppet En	1	
17	74274	(000000–) Geroter,Ring In En	1	
18	74275	(000000–) Geroter,Ring Ot En	1	
19	74277	(000000–) Coupler En	1	
20	74278	(000000–) Ring, Retaining En	2	
21	74279	(000000–) Actuator, Valve En	1	
22	74282	(000000–) Washer En	4	

NOTE: Piston Pump, TENNANT Part Number 74163, includes Fig. 3, and Fig. 4.

Fig. 5 – Hydraulic Piston Pump Breakdown, ~~65219~~ 62548

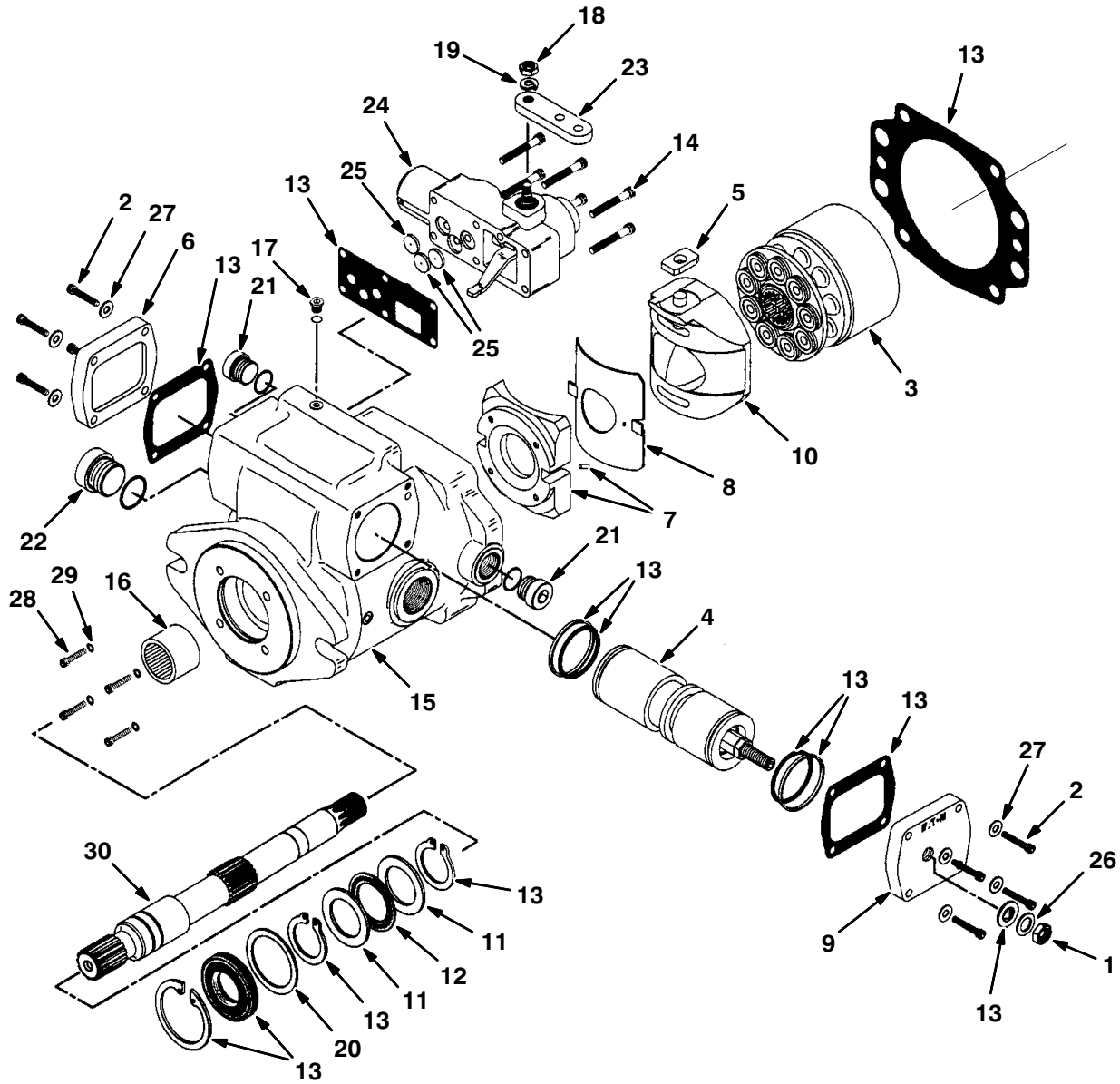

Fig. 5 – Hydraulic Piston Pump Breakdown, ~~65249~~ 62548

Ref.	Tennant Part No.	Machine Serial Number	Description	Qty.
∇	62548	(000000–)	Pump–Hyd Piston V 2.48 R4500	1
1	74184	(000000–)	Nut, Jam	1
2	74223	(000000–)	Screw, Cap	8
3	61882	(000000–)	Rotating Kit	1
4	74286	(000000–)	Servo Piston Sa En	1
5	74287	(000000–)	Follower,Piston En	1
6	74256	(000000–)	Plate, Cover En	1
7	74288	(000000–)	Camplate Cradle En	1
8	74289	(000000–)	Cam Bushing En	1
9	74257	(000000–)	Plate, Cover En	1
10	74224	(000000–)	Camplate S/A En	1
11	74240	(000000–)	Race, Bearing Ce	2
12	74210	(000000–)	Bearing	1
13	79709	(000000–)	Seal Kit, Pump En	1
14	74262	(000000–)	Screw, Cap En	6
∇	15 79703	(000000–)	Housing S/A En	1
16	37462	(000000–)	Bearing	1
17	79742	(000000–)	Plug S/A En	1
18	74266	(000000–)	Nut En	1
19	74267	(000000–)	Lockwasher En	1
20	37460	(000000–)	Washer	1
21	13907	(000000–)	Plug #8	2
22	79779	(000000–)	Plug,#12 O–Ring Ph	1
23	74272	(000000–)	Arm, Control En	1
24	74285	(000000–)	Control, Manual (see Breakdown)	1
25	74276	(000000–)	Orifice, Valve En	3
26	74280	(000000–)	Washer En	1
27	74281	(000000–)	Washer En	8
28	79706	(000000–)	Screw, Cap En	4
29	79707	(000000–)	Washer En	4
30	74265	(000000–)	Shaft, Drive Sp En	1

NOTE: Piston Pump, TENNANT Part Number ~~74163~~, includes Fig. 5, and Fig. 6.

62548

Fig. 6 – Hydraulic Piston Pump Breakdown, ~~65219~~ 62548

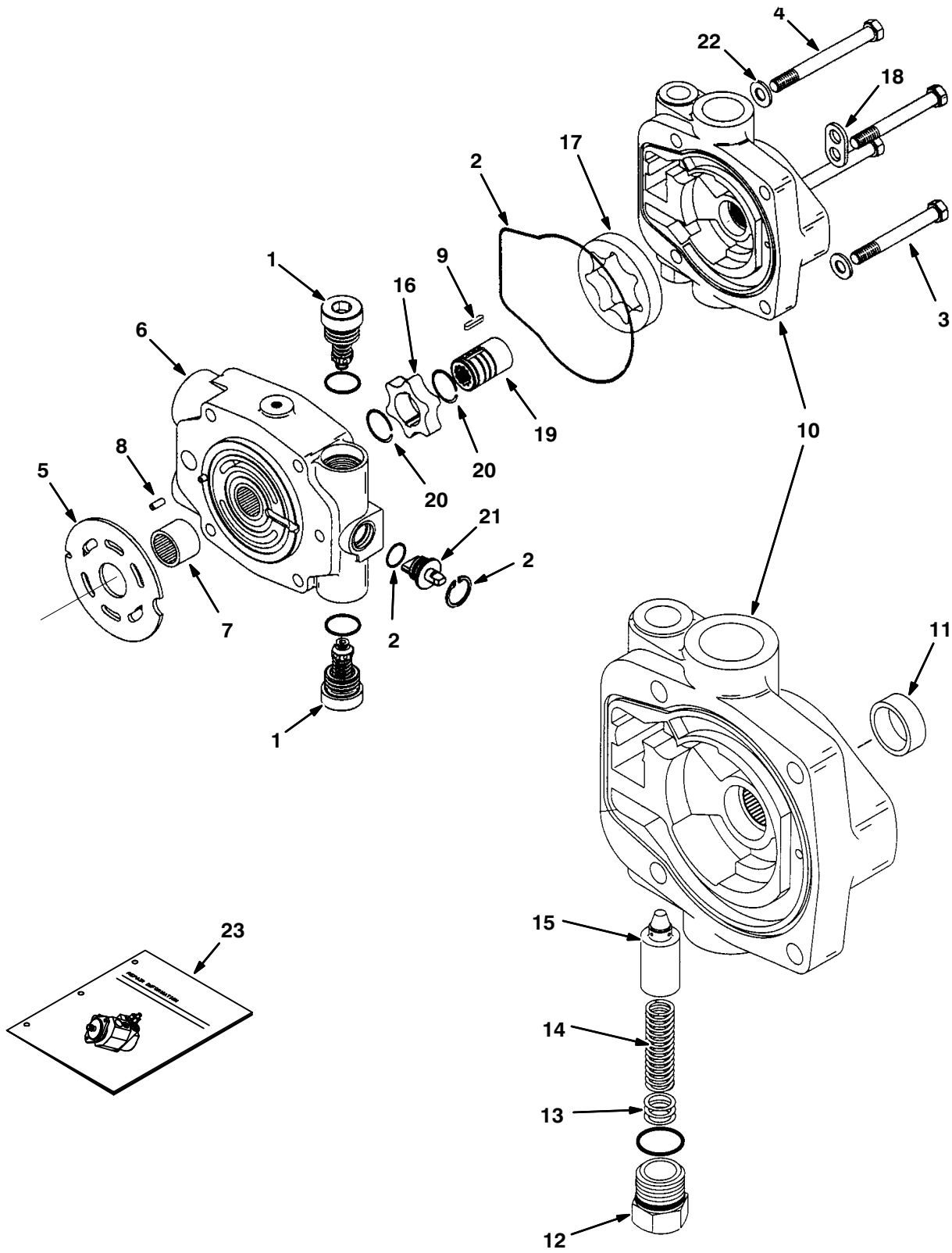

Fig. 6 – Hydraulic Piston Pump Breakdown, ~~65219~~62548

Ref.	Tennant Part No.	Machine Serial Number	Description	Qty.	
∇	62548	(000000–) Pump–Hyd Piston V 2.48 R4500	1	
1	74259	(000000–) Relief Valve Sa En	2	
2	79709	(000000–) Seal Kit, Pump En	1	
3	74260	(000000–) Screw, Cap En	2	
4	74261	(000000–) Screw, Cap En	2	
5	61886	(000000–) Valve Plate	1	
∇	6	79704	(000000–) Backplate S/A En	1
7	34159	(000000–) Bearing	1	
8	79748	(000000–) Roll Pin En	1	
9	74270	(000000–) Key En	1	
∇	10	74271	(000000–) Charge Pmp Adap En	1
11	79749	(000000–) Bushing En	1	
12	79750	(000000–) Plug En	1	
13	79751	(000000–) Shims En	1	
14	79752	(000000–) Spring En	1	
15	79753	(000000–) Poppet En	1	
16	74274	(000000–) Geroter,Ring In En	1	
17	74275	(000000–) Geroter,Ring Ot En	1	
18	79705	(000000–) Strap, Shipping En	1	
19	74277	(000000–) Coupler En	1	
20	74278	(000000–) Ring, Retaining En	2	
21	74279	(000000–) Actuator, Valve En	1	
22	74282	(000000–) Washer En	4	
23	74284	(000000–) Repair Info,Pmp En	1	

NOTE: Piston Pump, TENNANT Part Number ~~74163~~, includes Fig. 5, and Fig. 6.

62548

Fig. 7 – Hydraulic Piston Pump Breakdown, 74164

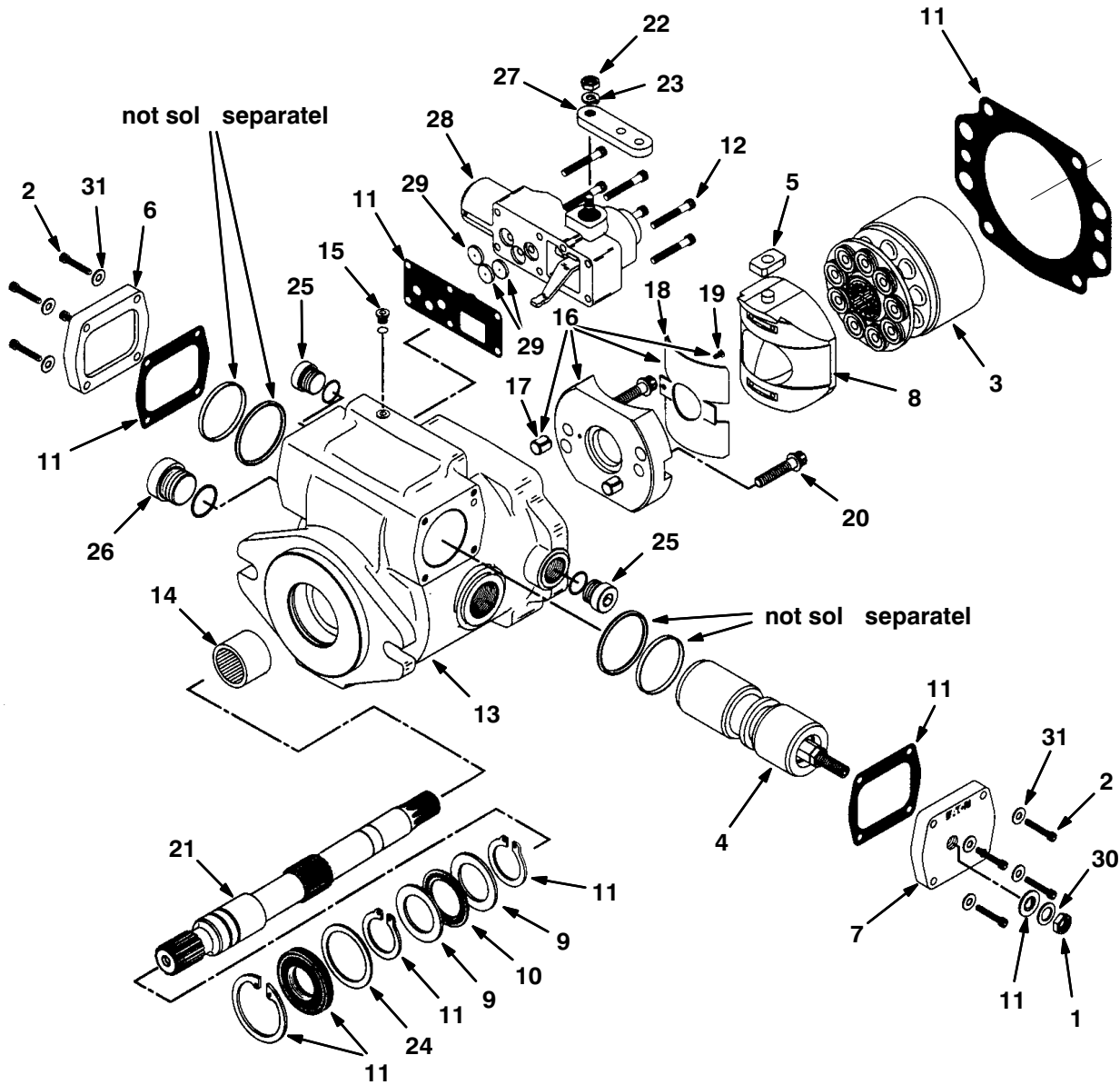

Fig. 7 – Hydraulic Piston Pump Breakdown, 74164

Ref.	Tennant Part No.	Machine Serial Number	Description	Qty.
▽	74164	(000000–) Pump, Hyd Piston V 2.48 R4500	1
1	74184	(000000–) Nut, Jam	1
2	74223	(000000–) Screw, Cap	8
3	61882	(000000–) Rotating Kit	1
4	74253	(000000–) Piston, Servo	1
5	74254	(000000–) Follower, Piston	1
6	74256	(000000–) Plate, Cover En	1
7	74257	(000000–) Plate, Cover En	1
8	74258	(000000–) Camplate S/A En	1
9	74240	(000000–) Race, Bearing Ce	2
10	74210	(000000–) Bearing	1
11	74283	(000000–) Seal Kit, Pump En	1
12	74262	(000000–) Screw, Cap En	6
▽	74263	(000000–) Housing S/A En	1
13	79771	(000000–) Housing En	1
14	37462	(000000–) Bearing	1
15	79742	(000000–) Plug S/A En	1
▽	16	79743	(000000–) Cradle Sub Assy En	1
17	79744	(000000–) Dowel Bushing En	2
18	79745	(000000–) Bushing En	1
19	79746	(000000–) Cap Screw En	1
20	79747	(000000–) Cap Screw En	2
21	74265	(000000–) Shaft, Drive Sp En	1
22	74266	(000000–) Nut En	1
23	74267	(000000–) Lockwasher En	1
24	37460	(000000–) Washer	1
25	13907	(000000–) Plug #8	2
26	79779	(000000–) Plug,#12 O–Ring Ph	1
27	74272	(000000–) Arm, Control En	1
28	74285	(000000–) Control, Manual (see Breakdown)	1
29	74276	(000000–) Orifice, Valve En	1
30	74280	(000000–) Washer En	1
31	74281	(000000–) Washer En	8

NOTE: Piston Pump, TENNANT Part Number 74164, includes Fig. 7, and Fig. 8.

Fig. 8 – Hydraulic Piston Pump Breakdown, 74164

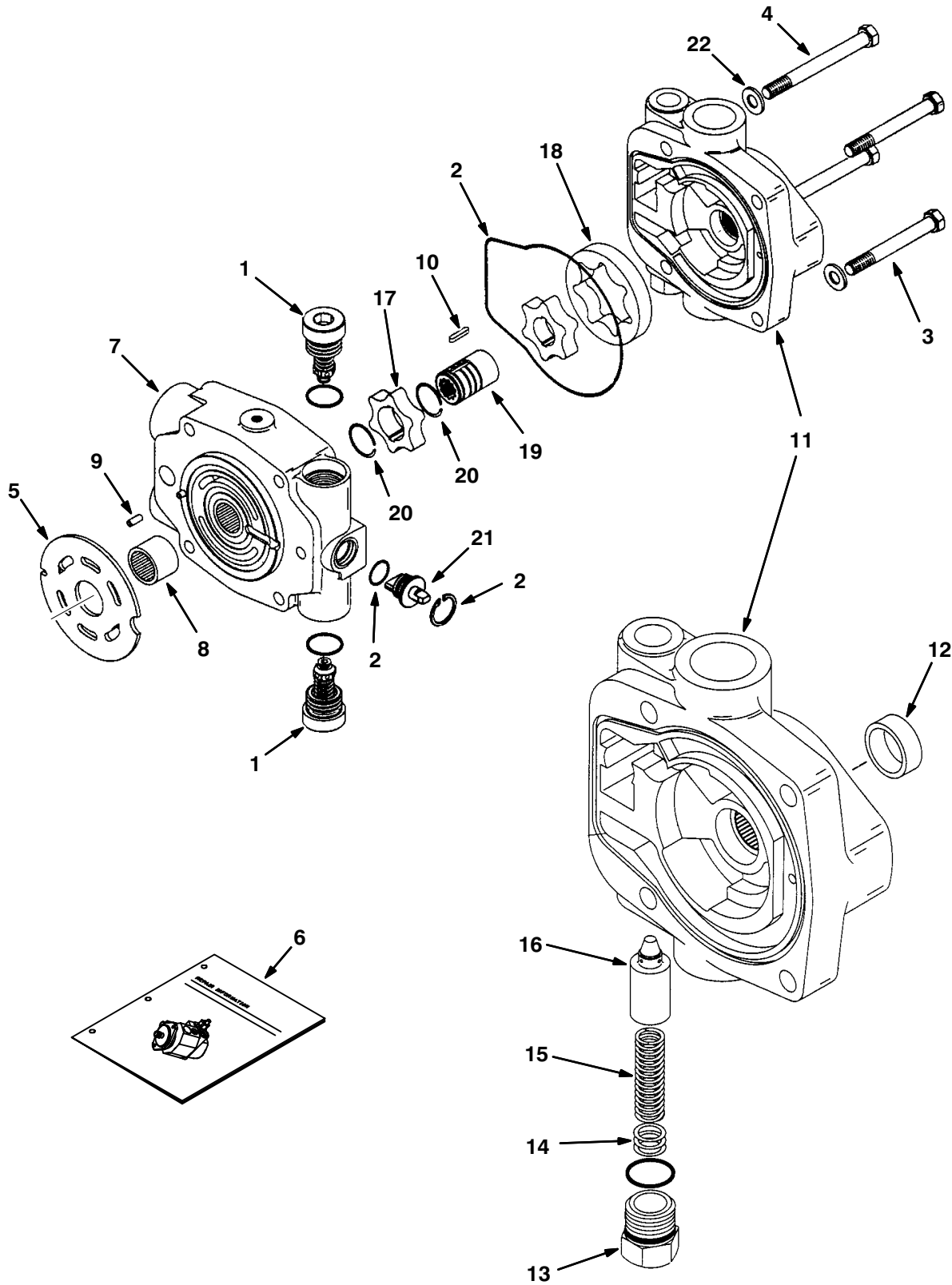
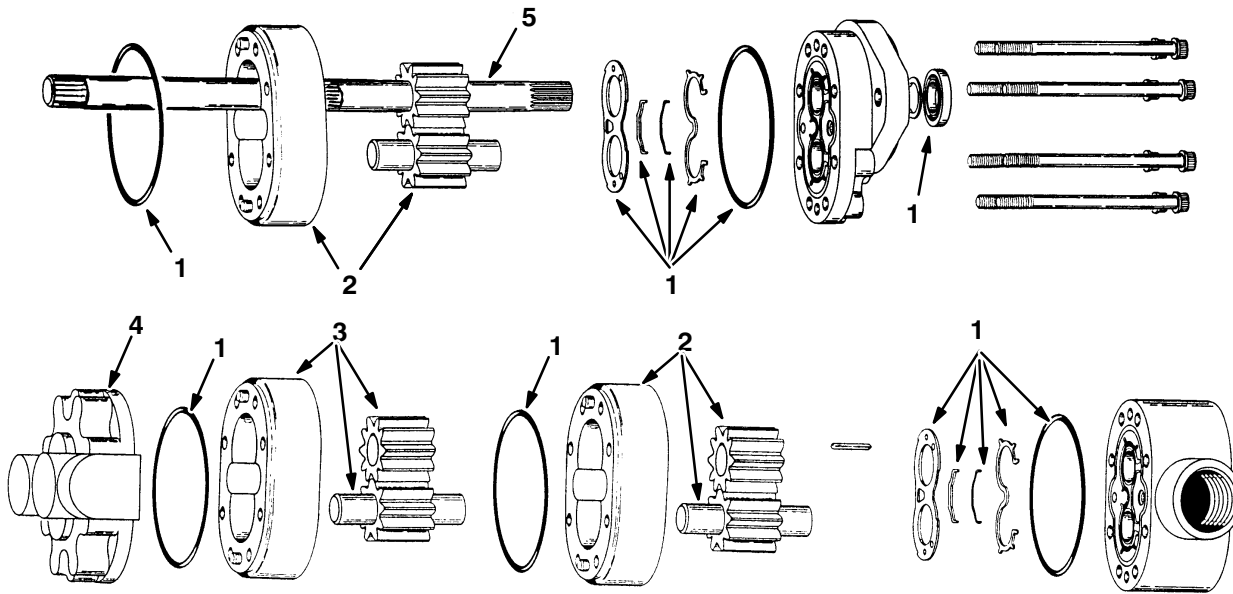

Fig. 8 – Hydraulic Piston Pump Breakdown, 74164

Ref.	Tennant Part No.	Machine Serial Number	Description	Qty.	
∇	74164	(000000–) Pump, Hyd Piston V 2.48 R4500	1	
1	74259	(000000–) Relief Valve Sa En	2	
2	74283	(000000–) Seal Kit, Pump En	1	
3	74260	(000000–) Screw, Cap En	2	
4	74261	(000000–) Screw, Cap En	2	
5	61886	(000000–) Valve Plate	1	
6	79708	(000000–) Repair Info,Pmp En	1	
∇	7	74264	(000000–) Backplate S/A En	1
8	34159	(000000–) Bearing	1	
9	79748	(000000–) Roll Pin En	1	
10	74270	(000000–) Key En	1	
∇	11	74271	(000000–) Charge Pmp Adap En	1
12	79749	(000000–) Bushing En	1	
13	79750	(000000–) Plug En	1	
14	79751	(000000–) Shims En	1	
15	79752	(000000–) Spring En	1	
16	79753	(000000–) Poppet En	1	
17	74274	(000000–) Geroter,Ring In En	1	
18	74275	(000000–) Geroter,Ring Ot En	1	
19	74277	(000000–) Coupler En	1	
20	74278	(000000–) Ring, Retaining En	2	
21	74279	(000000–) Actuator, Valve En	1	
22	74282	(000000–) Washer En	4	

NOTE: Piston Pump, TENNANT Part Number 74164, includes Fig. 7, and Fig. 8.

Fig. 9 – Hydraulic Gear Pump Breakdown, 62561



07630/07488

Ref.	Tennant Part No.	Machine Serial Number	Description	Qty.
▽	62561	(000000–) Pump, Gear	1
1	59305	(000000–) Seal Kit	1
2	58012	(000000–) Body and Gear Kit, .66 CIR	2
3	58013	(000000–) Body and Gear Kit, .50 CIR	1
4	58242	(000000–) Back Plate Assembly	1
5	65226	(000000–) Drive Shaft	1

Fig. 10 – Hydraulic Motor Breakdown, 63426

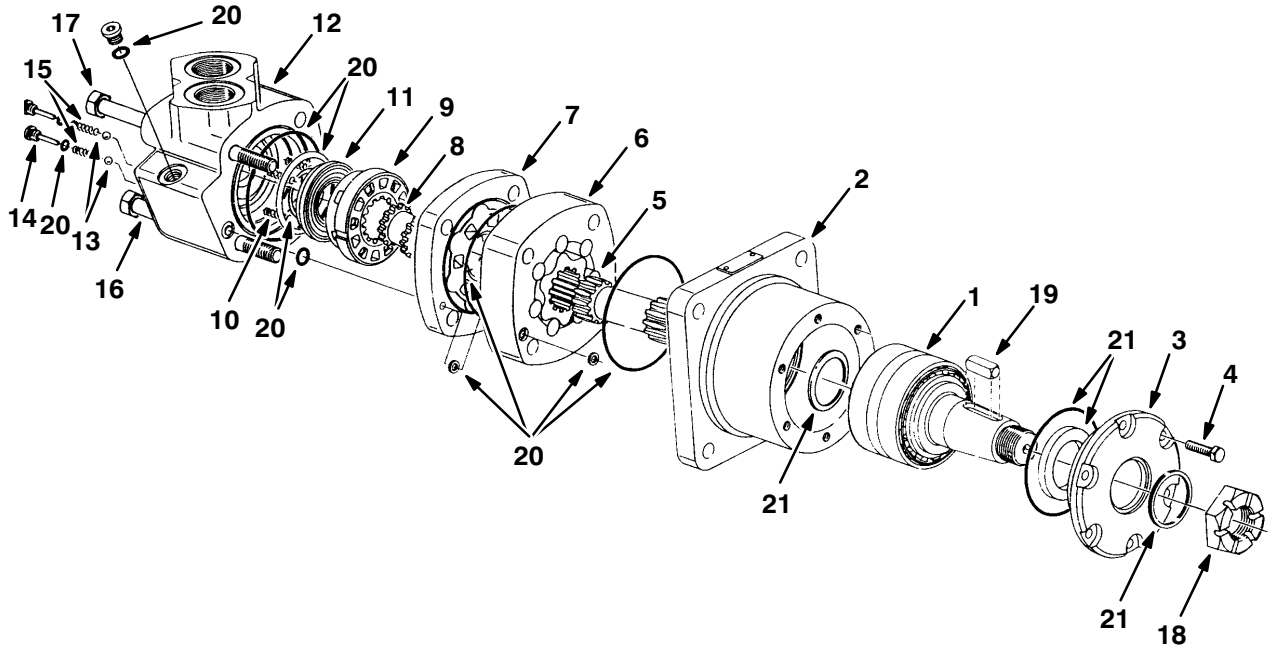

07635/01655

Ref.	Tennant Part No.	Machine Serial Number	Description	Qty.
▽	63426	(000000–) Motor, Propelling	1
1	34180	(000000–) Shaft and Brg	1
2	74132	(000000–) Housing, Brg	1
3	74133	(000000–) Retainer, Frt	1
4	37943	(000000–) Bolt	6
5	34181	(000000–) Drive	1
6	34182	(000000–) Gerotor Set	1
7	34184	(000000–) Valve Plate	1
8	34183	(000000–) Drive, Valve	1
9	34185	(000000–) Valve	1
10	34178	(000000–) Spring	3
11	37723	(000000–) Plate	1
12	74134	(000000–) Housing Assy	1
13	37766	(000000–) Ball	2
14	74137	(000000–) Plug Assembly	2
15	34179	(000000–) Spring	2
16	74135	(000000–) Screw, Cap	2
17	74136	(000000–) Screw, Cap	2
18	45622	(000000–) Nut	1
19	45623	(000000–) Key	1
20	40380	(000000–) Seal Kit, Motor	1
21	65227	(000000–) Seal Kit, Shaft	1

Fig. 11 – Hydraulic Motor Breakdown, 53434

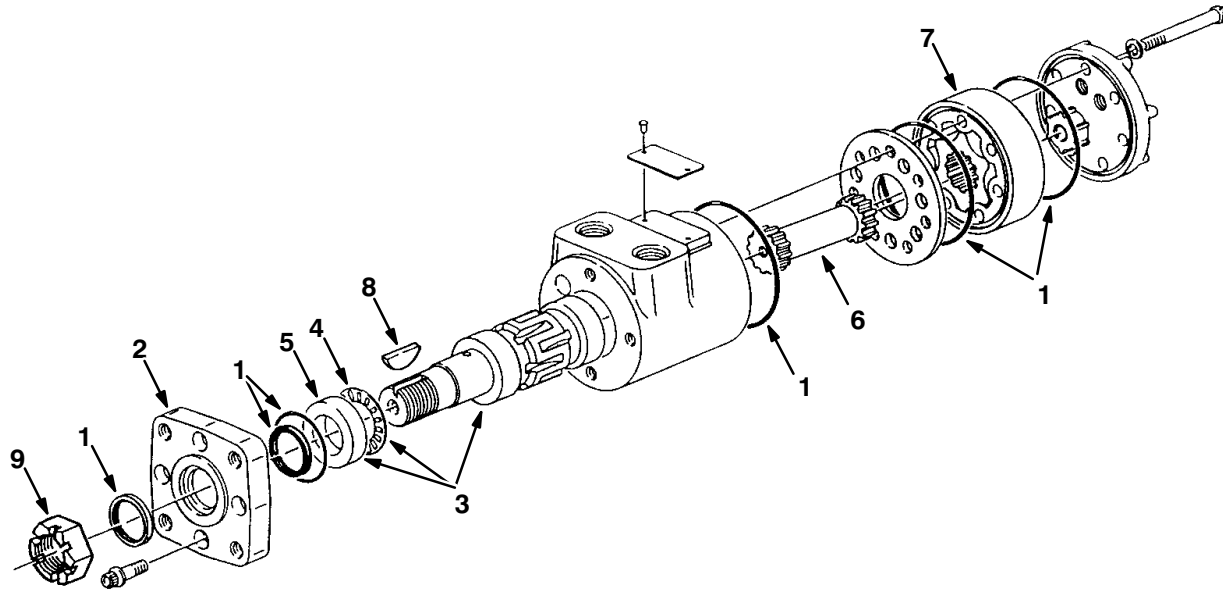

07907/05348

Ref.	Tennant Part No.	Machine Serial Number	Description	Qty.
▽	53434	(000000–) Motor, Hydraulic	1
1	61490	(000000–) Seal Kit	1
2	31354	(000000–) Flange, Mounting	1
▽	3	58278	(000000–) Output Shaft Assembly	1
4	45628	(000000–) Bearing	1
5	16695	(000000–) Race, Thrust	1
6	34176	(000000–) Drive	1
7	58270	(000000–) Gerotor Set	1
8	00500–15	(000000–) Key, Woodruff	1
9	39527	(000000–) Nut, Slotted Hex	1

Fig. 12 – Hydraulic Motor Breakdown, 62564

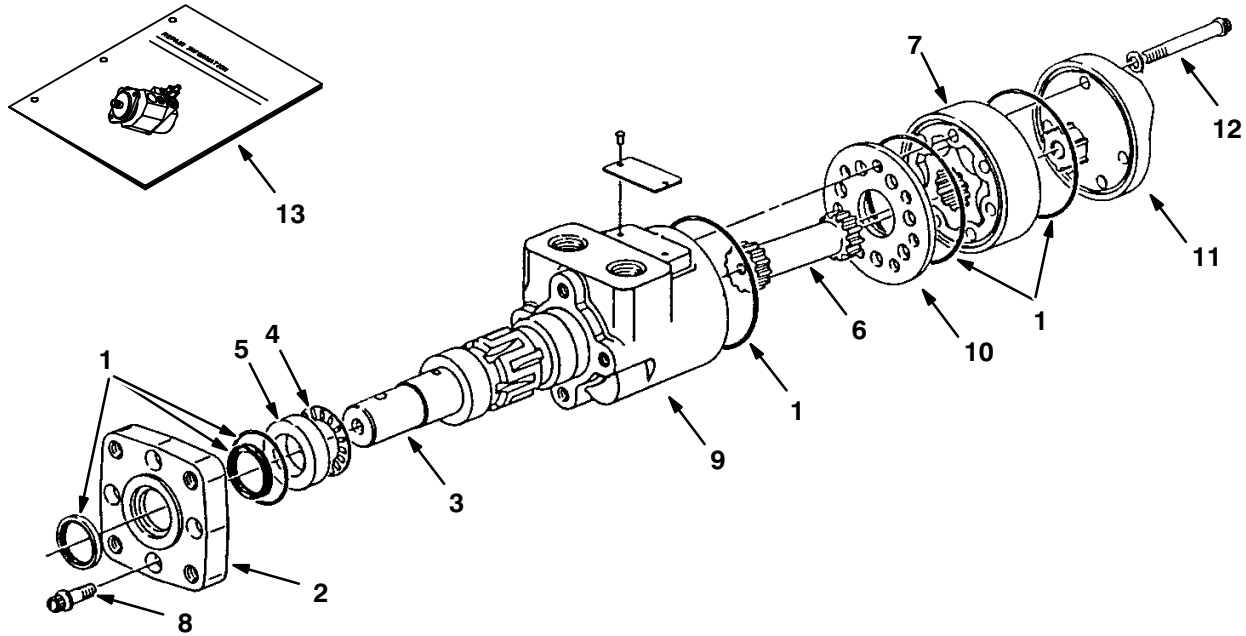

07642/07716,09670

Ref.	Tennant Part No.	Machine Serial Number	Description	Qty.
▽	62564	(000000–) Motor, Hydraulic (Repl. by 79781)	1
1	61490	(000000–) Seal Kit	1
2	31354	(000000–) Flange, Mounting	1
3	16694	(000000–) Shaft	1
4	45628	(000000–) Bearing Thrust	1
5	16695	(000000–) Race, Thrust	1
6	31380	(000000–) Drive	1
7	31385	(000000–) Gerotor Set	1
8	37555	(000000–) Screw	4
9	74100	(000000–) Housing	1
10	74094	(000000–) Spacer Plate	1
11	74101	(000000–) End Cap	1
12	65232	(000000–) Cap Screw	5
13	74250	(000000–) Repair Info, Motor	1

Fig. 13 – Hydraulic Motor Breakdown, 79781

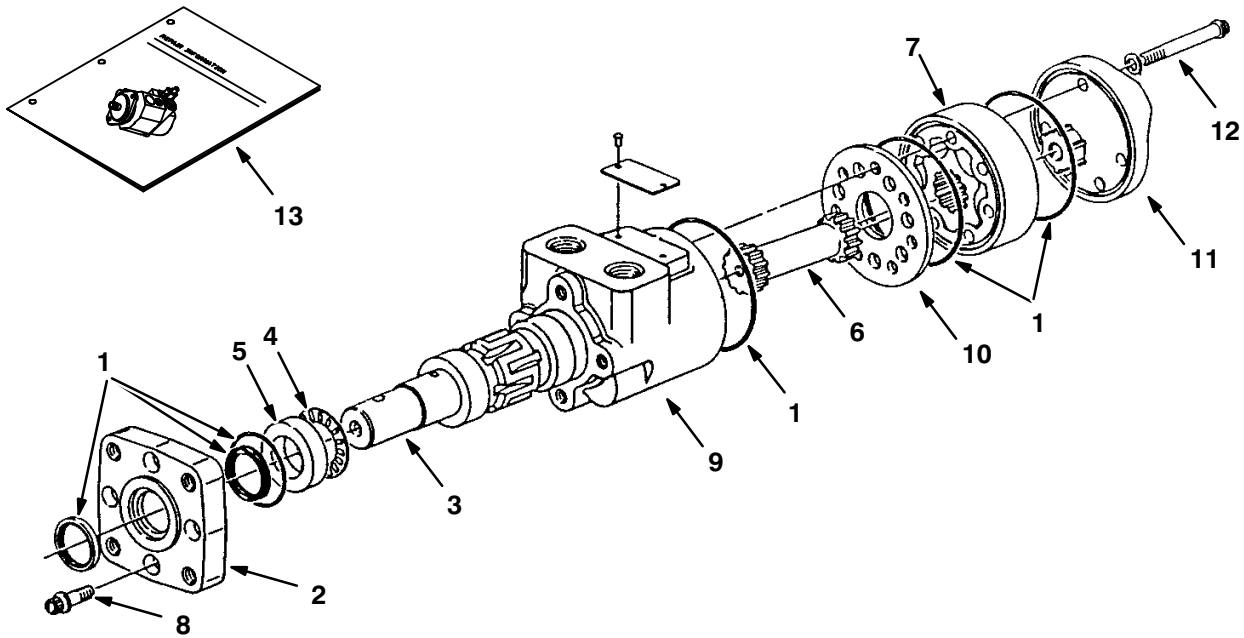

10631/07716,09670

Ref.	Tennant Part No.	Machine Serial Number	Description	Qty.
▽	79781	(000000–) Motor, Hydraulic	1
1	61490	(000000–) Seal Kit	1
2	79782	(000000–) Flange, Mounting	1
3	16694	(000000–) Shaft	1
4	45628	(000000–) Bearing Thrust	1
5	16695	(000000–) Race, Thrust	1
6	31380	(000000–) Drive	1
7	31385	(000000–) Gerotor Set	1
8	37555	(000000–) Screw	4
9	74100	(000000–) Housing	1
10	74094	(000000–) Spacer Plate	1
11	74101	(000000–) End Cap	1
12	65232	(000000–) Cap Screw	5
13	74250	(000000–) Repair Info, Motor	1

Fig. 14 – Hydraulic Motor Breakdown, 19117

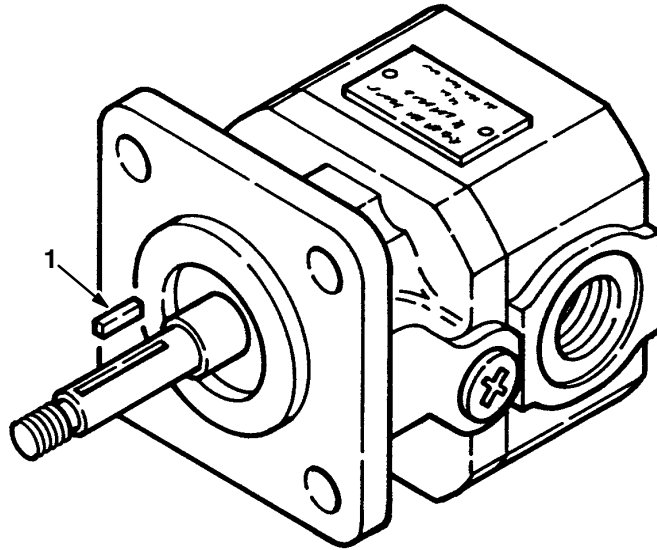

05187/05190

Ref.	Tennant Part No.	Machine Serial Number	Description	Qty.
∇	19117	(000000–) Motor, Hydraulic	1
1	00954	(000000–) Key	1
	74233	(000000–) Seal Kit	1

Fig. 15 – Hydraulic Motor Breakdown, 63542

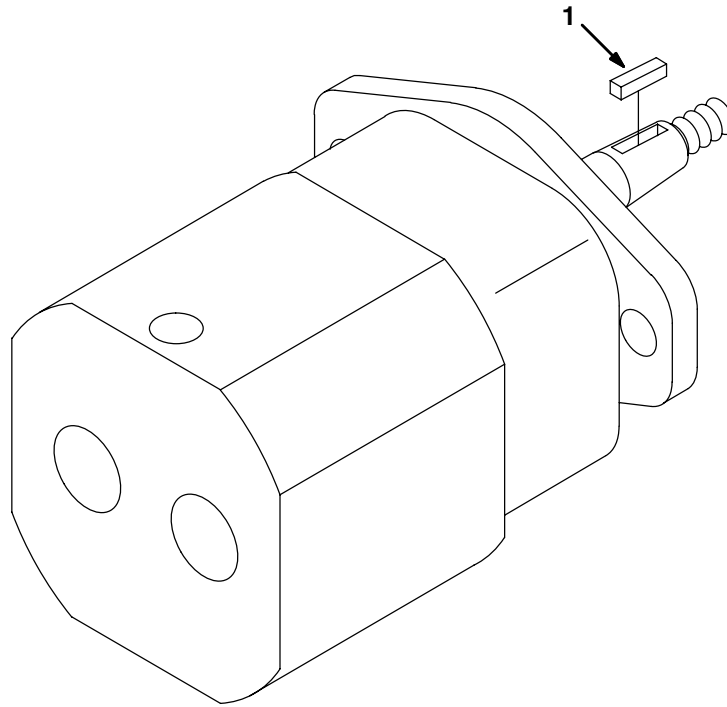

07631/10556

Ref.	Tennant Part No.	Machine Serial Number	Description	Qty.
∇	63542	(000000–) Motor, Hydraulic	1
1	00960	(000000–) Key, Square 0.12 0.12 00.50 LG	1
	74233	(000000–) Seal Kit, Hyd Mtr Gear	1

Fig. 16 – Hydraulic Steering Valve Breakdown, 62565

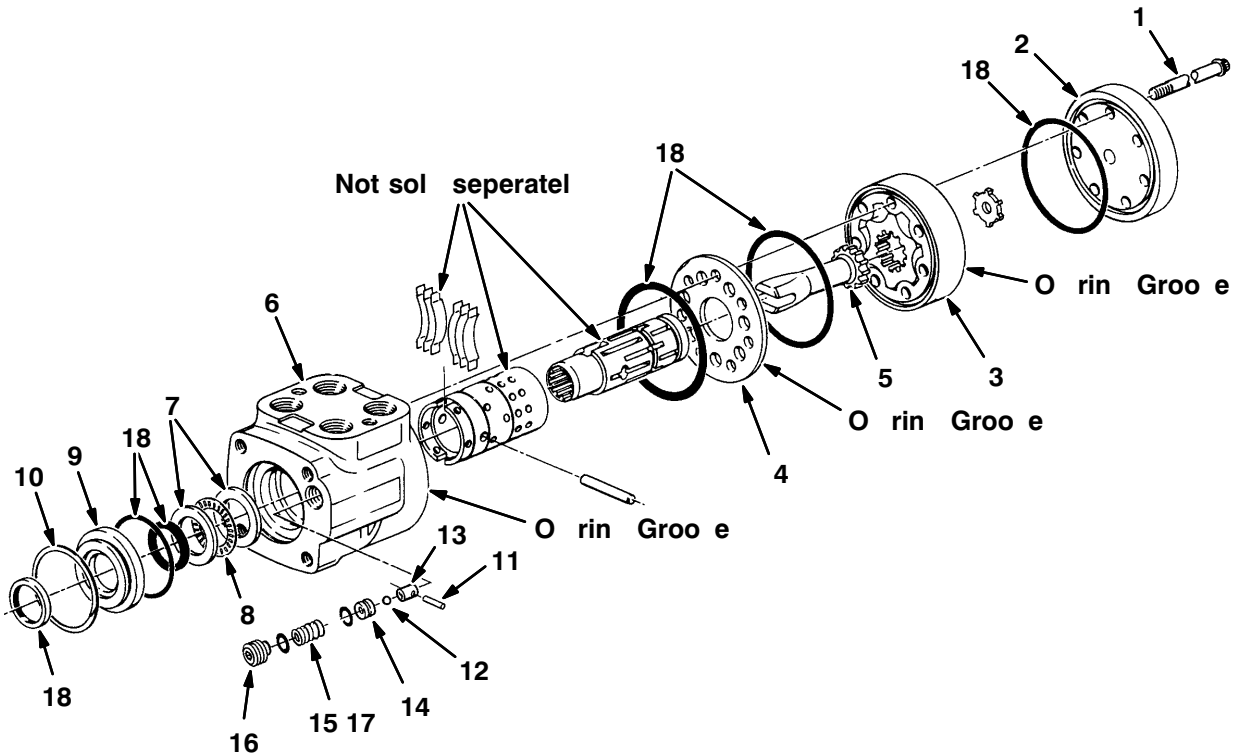

07636/07491

Ref.	Tennant Part No.	Machine Serial Number	Description	Qty.
▽	62565	(000000–)	Steer Control, Hyd#4 04.5 1300	1
1	65233	(000000–)	Cap Screw CI	6
2	65234	(000000–)	Cap, End CI	1
3	65235	(000000–)	Gerotor Set CI	1
4	74106	(000000–)	Spacer Plate	1
5	58596	(000000–)	Drive	1
6	65236	(000000–)	Control Assy CI	1
7	74109	(000000–)	Race, Bearing	2
8	74110	(000000–)	Bearing, Needle	1
9	74112	(000000–)	Bushing, Seal	1
10	74111	(000000–)	Ring, Retainer	1
11	74113	(000000–)	Pin, Spring CI	1
12	74114	(000000–)	Ball, Check CI	1
13	74115	(000000–)	Seat	1
14	74116	(000000–)	Poppet	1
15	65237	(000000–)	Spring, Comp. CI	1
16	74118	(000000–)	Plug	1
17	65238	(000000–)	Spring, Comp. CI	1
18	57152	(000000–)	Seal Kit,Stg	1

Fig. 17 – Hydraulic Steering Valve Breakdown, 65242

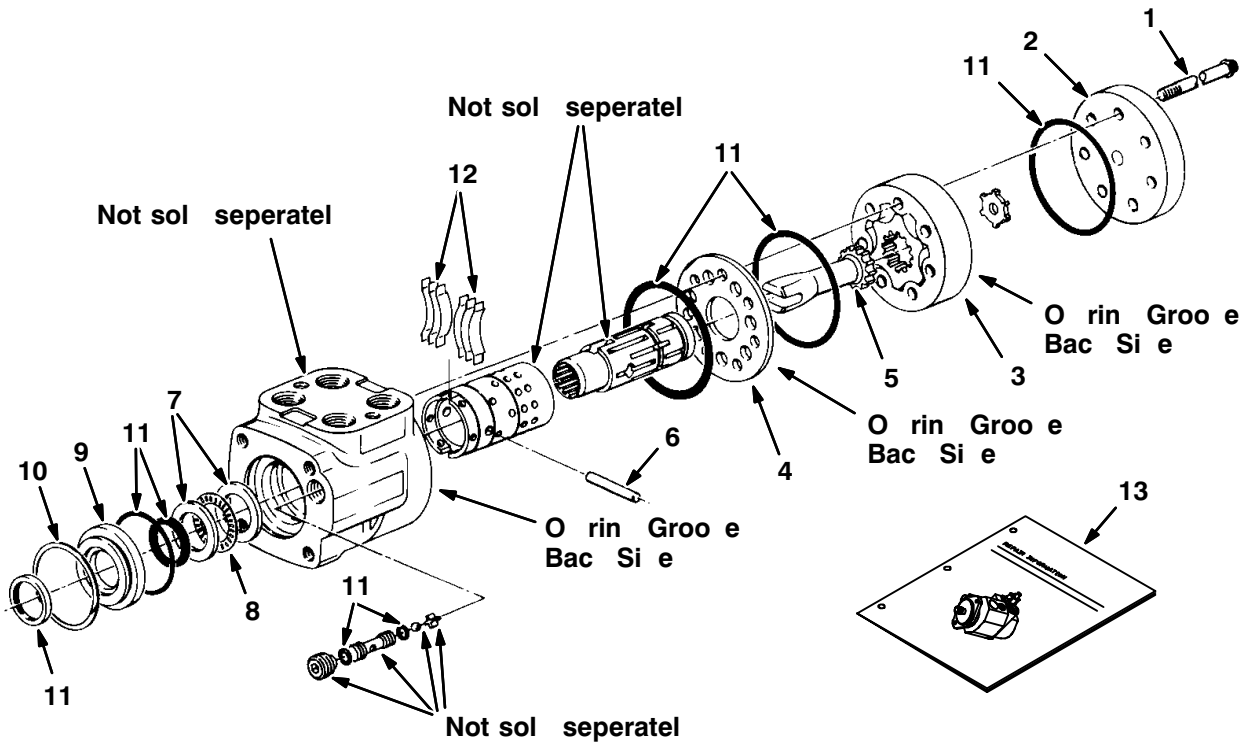

09937/09936/09670

Ref.	Tennant Part No.	Machine Serial Number	Description	Qty.
∇	65242	(000000–)	Steer Control Hyd#4 04.5 1300	1
1	74174	(000000–)	Cap, Screw	6
2	74194	(000000–)	Cap, End	1
3	65235	(000000–)	Gerotor Set Cl	1
4	74182	(000000–)	Plate, Wear	1
5	58596	(000000–)	Drive	1
6	74218	(000000–)	Pin	1
7	74109	(000000–)	Race, Bearing	2
8	74110	(000000–)	Bearing, Needle	1
9	74112	(000000–)	Bushing, Seal	1
10	74111	(000000–)	Ring, Retainer	1
11	74190	(000000–)	Seal Kit, Scu	1
12	74251	(000000–)	Repair Info,Scu Cl	1

Fig. 18 – Hydraulic Solenoid Valve Breakdown, 65391

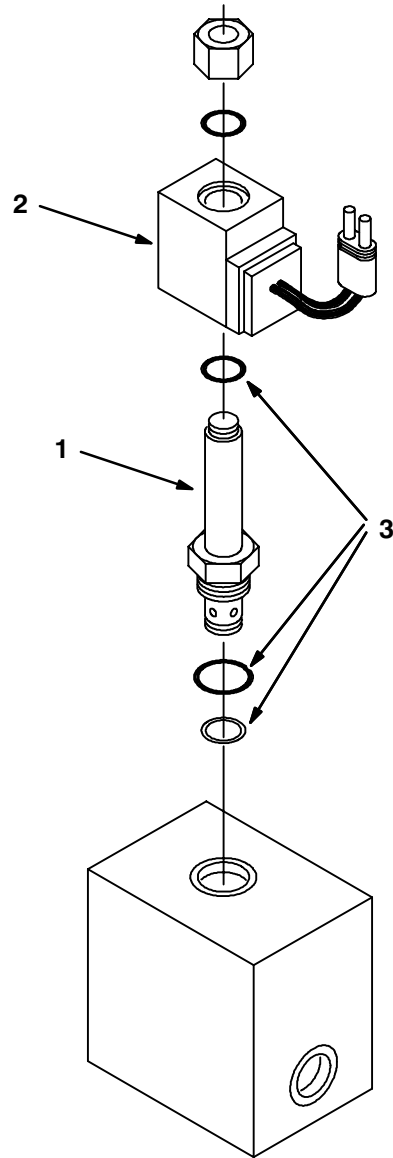

07638/07639

Ref.	Tennant Part No.	Machine Serial Number	Description	Qty.
∇	65391	(000000–) Valve–Hyd, Solenoid	1
1	61927	(000000–) Valve Stem N.O.	1
2	35493	(000000–) Coil 12Vdc	1
3	48813	(000000–) Seal Kit, One Cart	1

Fig. 19 – Hydraulic Solenoid Valve Breakdown, 84015

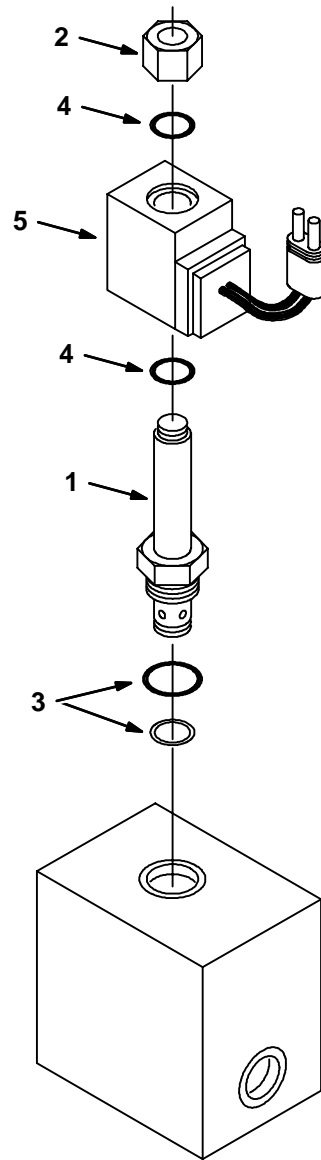

10632/07639

Ref.	Tennant Part No.	Machine Serial Number	Description	Qty.
∇	84015	(000000–)	Valve – Hyd., Solenoid	1
∇	1 79739	(000000–)	Valve Stem, N.D.	1
	2 79731	(000000–)	Nut, Cart., LNG.	1
	3 79711	(000000–)	Seal Kit, Cart.	1
	4 79740	(000000–)	Seal Kit, Coil	1
	5 21917	(000000–)	Coil, 12V W/Var	1

Fig. 20 – Hydraulic Solenoid Valve Breakdown, 84016

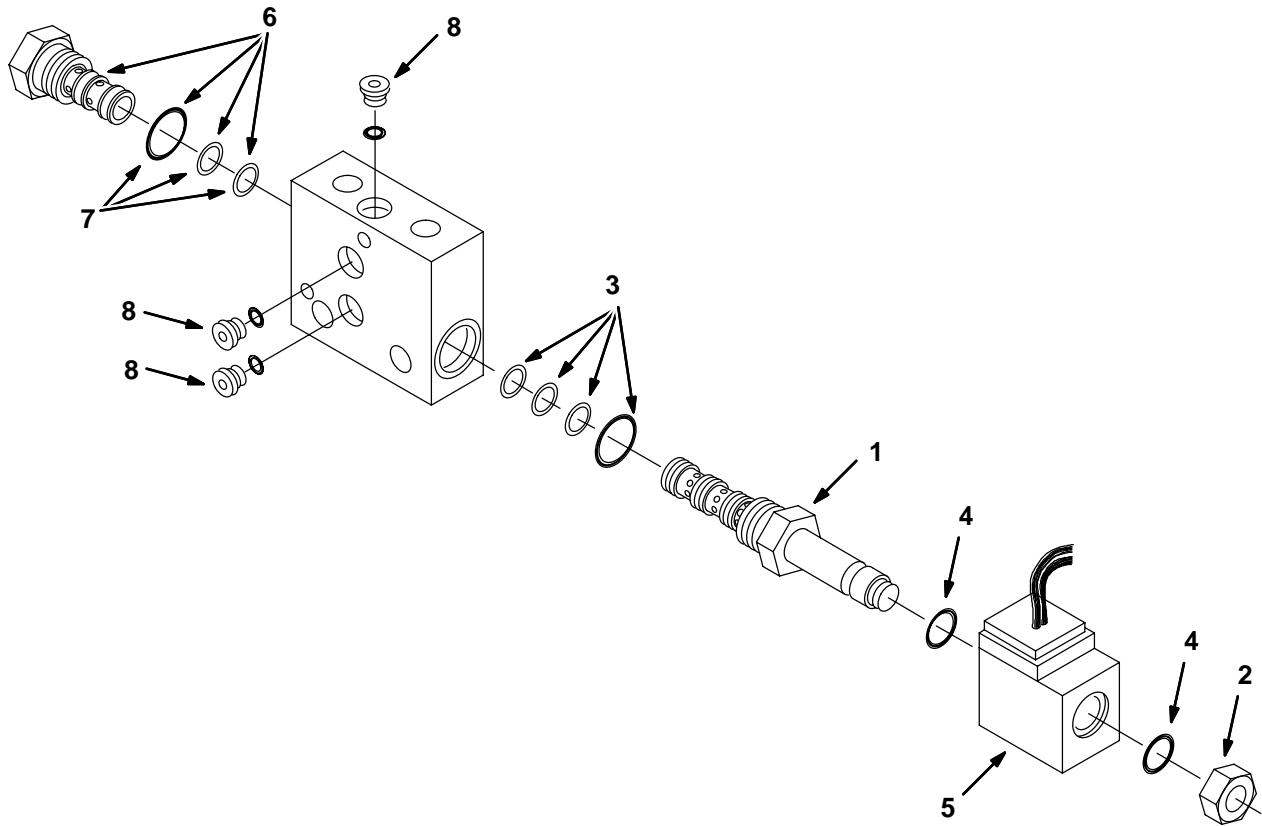

10500/10499

Ref.	Tennant Part No.	Machine Serial Number	Description	Qty.
▽	84016	(000000–) Valve, Hyd Control Solenoid	1
▽	1	79719	(000000–) Valve Stem 4W2P	1
	2	79728	(000000–) Nut, Cart., Sht	1
	3	79711	(000000–) Seal Kit, Cart	1
	4	79740	(000000–) Seal Kit, Coil	1
	5	21917	(000000–) Coil, 12V W/Var	1
▽	6	74145	(000000–) Cart, Pilot Cntr	1
	7	79711	(000000–) Seal Kit, Cart	1
	8	13902	(000000–) Plug, #2 O-Ring	3

Fig. 21 – Hydraulic Solenoid Valve Breakdown, 63527

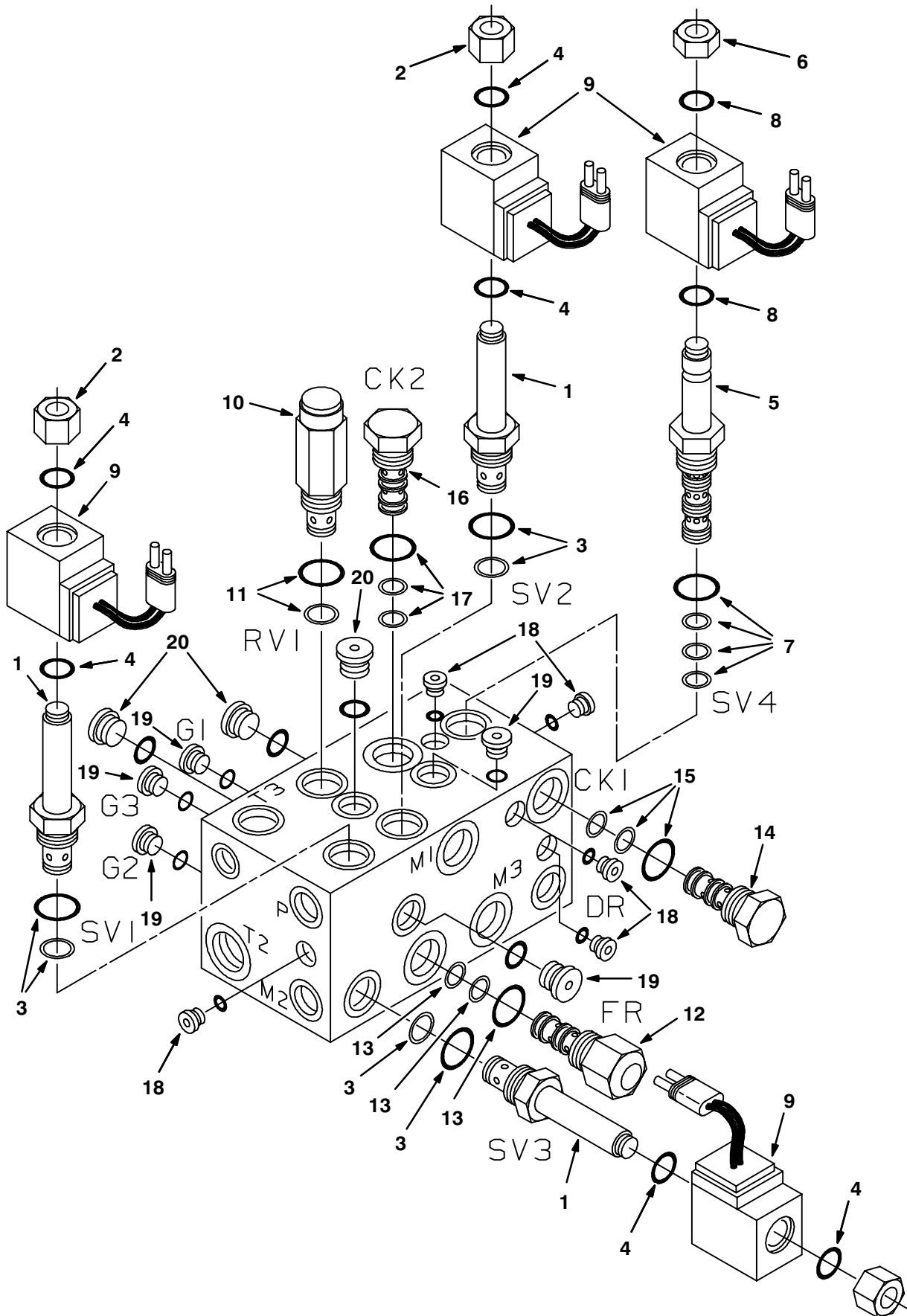

Fig. 21 – Hydraulic Solenoid Valve Breakdown, 63527

Ref.	Tennant Part No.	Machine Serial Number	Description	Qty.
∇	63527	(000000–)	Valve–Hyd, Cntl Solenoid	1
∇ 1	79739	(000000–)	Valve Stem N.O. CP	3
2	79731	(000000–)	Nut, Cart., LNG CP	1
3	79711	(000000–)	Seal Kit, Cart CP	1
4	79740	(000000–)	Seal Kit, C0il CP	1
∇ 5	79719	(000000–)	Valve Stem 4W2P CP	1
6	79728	(000000–)	Nut, Cart., SHT CP	1
7	79711	(000000–)	Seal Kit, Cart CP	1
8	79740	(000000–)	Seal Kit, C0il CP	1
9	79720	(000000–)	Coil 12V CP	4
∇ 10	65240	(000000–)	Cart, PSI CN CP	1
11	79711	(000000–)	Seal Kit, Cart CP	1
∇ 12	74268	(000000–)	Cart Flow Control CP	1
13	79711	(000000–)	Seal Kit, Cart CP	1
∇ 14	74145	(000000–)	Cart, Pilot CNTR CP	1
15	79711	(000000–)	Seal Kit, Cart CP	1
∇ 16	74146	(000000–)	Cart, Check Valve CP	1
17	79711	(000000–)	Seal Kit, Cart CP	1
18	13902	(000000–)	Plug #2	6
19	74098	(000000–)	Plug Gage #4	5
20	13904	(000000–)	Plug Gage #6	3

Fig. 22 – Hydraulic Solenoid Valve Breakdown, 78996

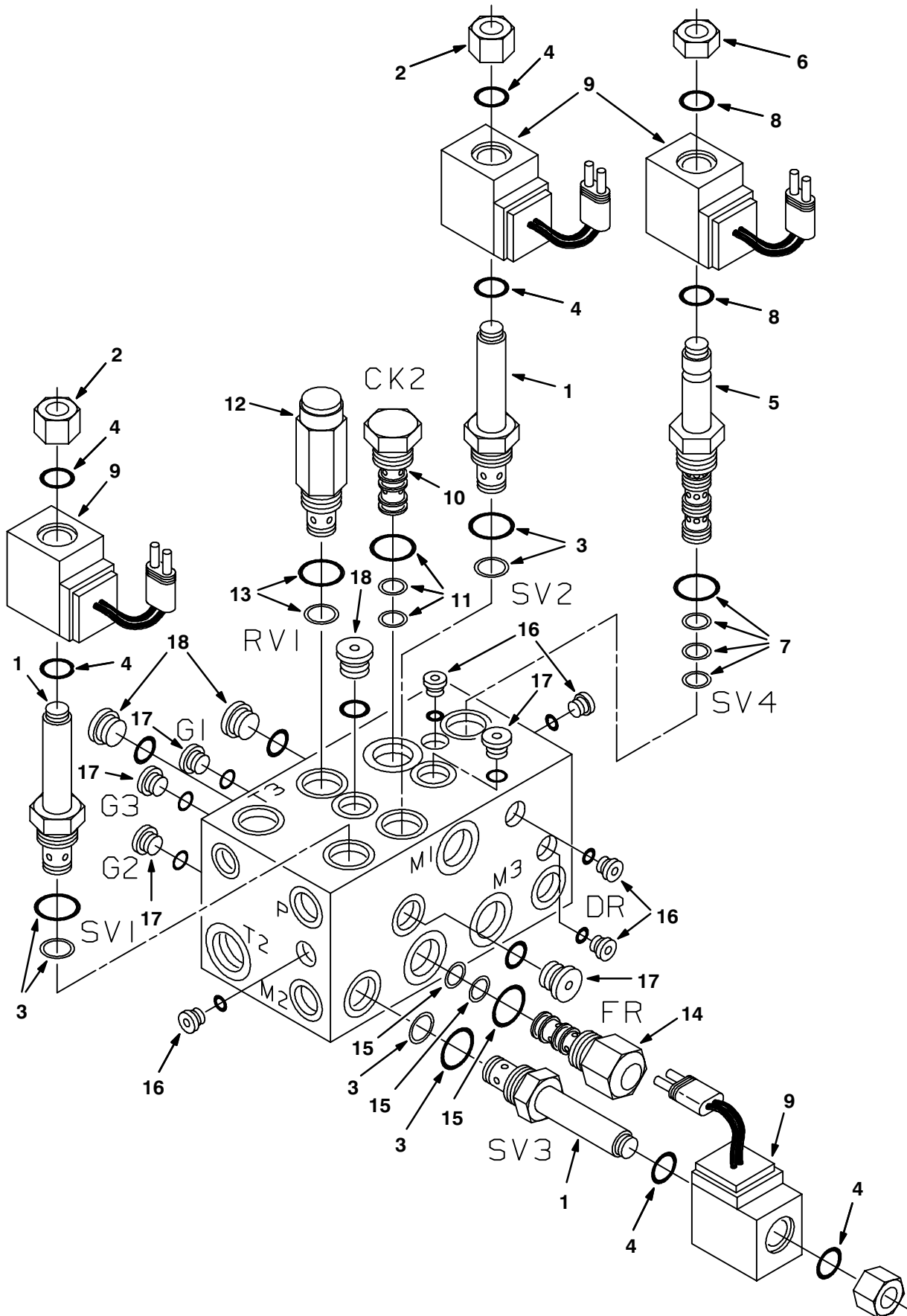

Fig. 22 – Hydraulic Solenoid Valve Breakdown, 78996

Ref.	Tenant Part No.	Machine Serial Number	Description	Qty.
▽	78996	(000000–) Valve–Hyd, Solenoid	1
▽ 1	79739	(000000–) Valve Stem N.O. CP	3
2	79731	(000000–) Nut, Cart., LNG CP	1
3	79711	(000000–) Seal Kit, Cart CP	1
4	79740	(000000–) Seal Kit, C0il CP	1
▽ 5	79719	(000000–) Valve Stem 4W2P CP	1
6	79728	(000000–) Nut, Cart., SHT CP	1
7	79711	(000000–) Seal Kit, Cart CP	1
8	79740	(000000–) Seal Kit, C0il CP	1
9	79720	(000000–) Coil 12V CP	4
▽ 10	74146	(000000–) Cart, Check Valve CP	1
11	79711	(000000–) Seal Kit, Cart CP	1
▽ 12	65240	(000000–) Cart, PSI CN CP	1
13	79711	(000000–) Seal Kit, Cart CP	1
▽ 14	74268	(000000–) Cart Flow Control CP	1
15	79711	(000000–) Seal Kit, Cart CP	1
16	13902	(000000–) Plug #2	6
17	74098	(000000–) Plug Gage #4	5
18	13904	(000000–) Plug Gage #6	3

Fig. 23 – Hydraulic Solenoid Valve Breakdown, 84014

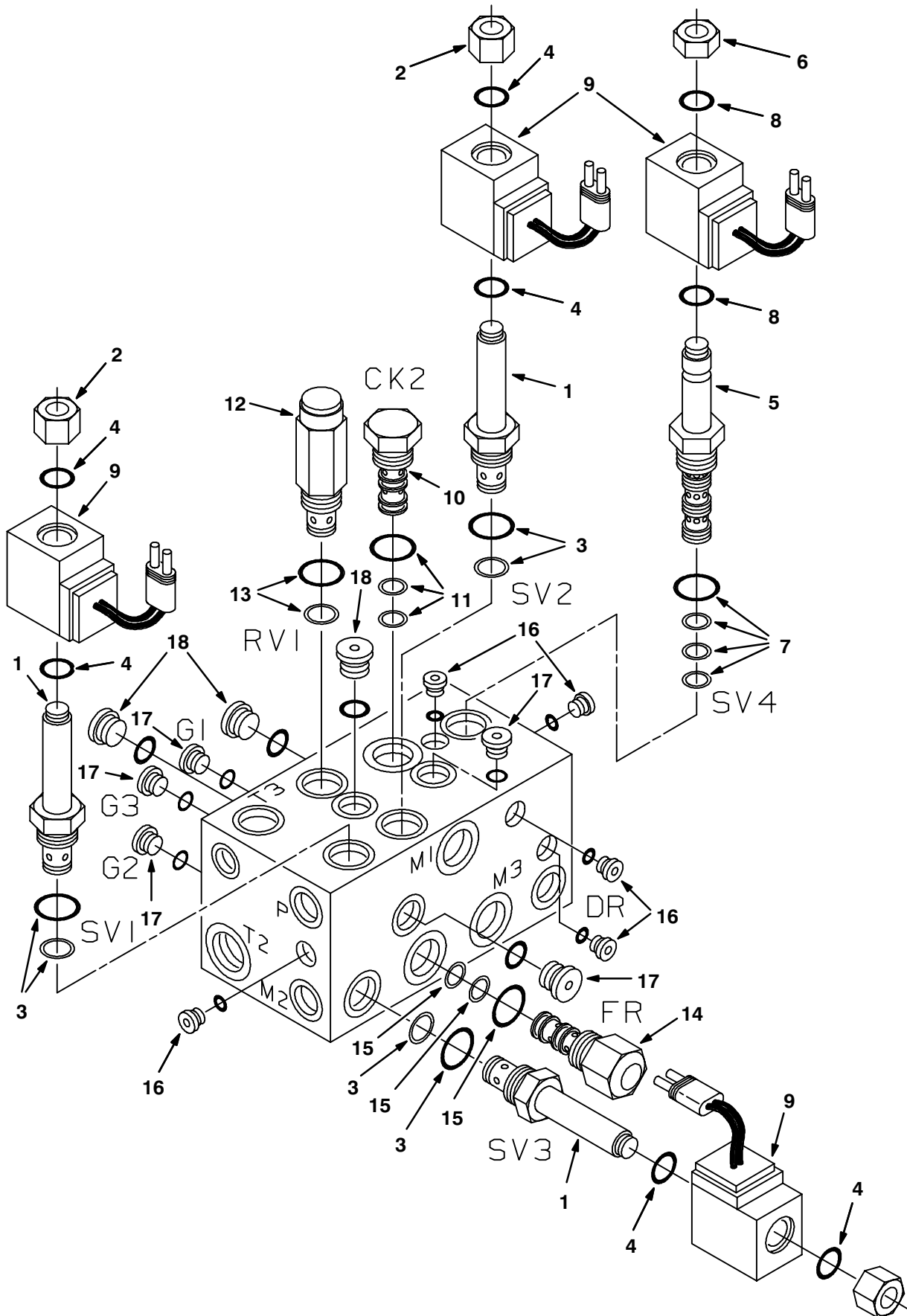
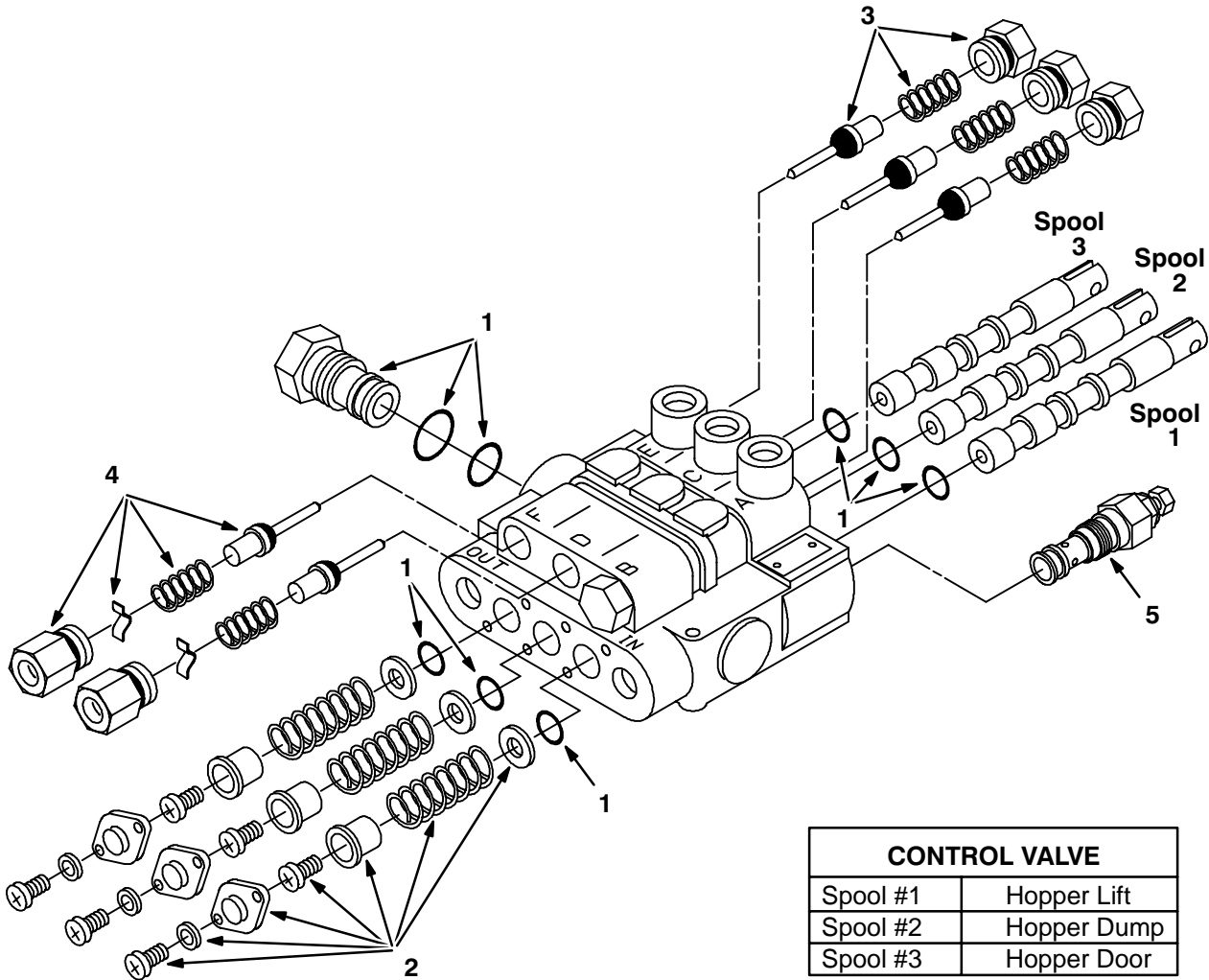

Fig. 23 – Hydraulic Solenoid Valve Breakdown, 84014

Ref.	Tenant Part No.	Machine Serial Number	Description	Qty.
∇	84014	(000000–) Valve, Hyd Control Solenoid	1
∇ 1	79739	(000000–) Valve Stem N.O. CP	3
2	79731	(000000–) Nut, Cart., LNG CP	1
3	79711	(000000–) Seal Kit, Cart CP	1
4	79740	(000000–) Seal Kit, Coil CP	1
∇ 5	79719	(000000–) Valve Stem 4W2P CP	1
6	79728	(000000–) Nut, Cart., SHT CP	1
7	79711	(000000–) Seal Kit, Cart CP	1
8	79740	(000000–) Seal Kit, Coil CP	1
9	21917	(000000–) Coil 12V w/Var CP	4
∇ 10	74146	(000000–) Cart, Check Valve CP	1
11	79711	(000000–) Seal Kit, Cart CP	1
∇ 12	65240	(000000–) Cart, PSI CN CP	1
13	79711	(000000–) Seal Kit, Cart CP	1
∇ 14	74268	(000000–) Cart Flow Control CP	1
15	79711	(000000–) Seal Kit, Cart CP	1
16	13902	(000000–) Plug #2	6
17	74098	(000000–) Plug Gage #4	5
18	13904	(000000–) Plug Gage #6	3

Fig. 24 – Hydraulic Valve Breakdown, 62567



CONTROL VALVE	
Spool #1	Hopper Lift
Spool #2	Hopper Dump
Spool #3	Hopper Door

07640/07641

Ref.	Tennant Part No.	Machine Serial Number	Description	Qty.
▽	62567	(000000–) Valve, Hydraulic	1
1	74128	(000000–) Seal Kit	1
2	74126	(000000–) Spring Kit	3
3	74129	(000000–) Check Kit, Pilot	3
4	74130	(000000–) Check Kit, Pilot	2
5	74131	(000000–) Relief Cart.	1

Fig. 25 – Hydraulic Valve Breakdown, 77495

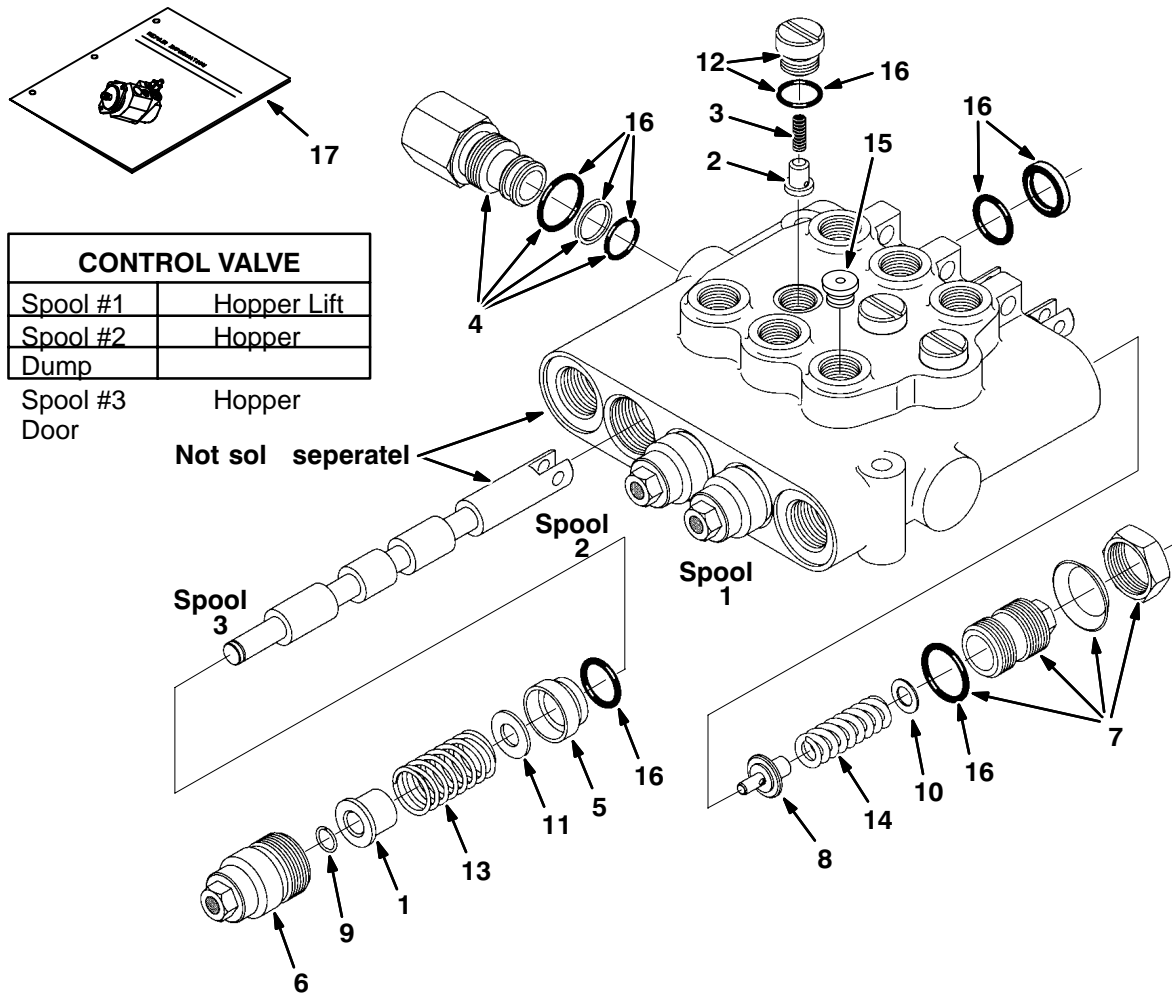

10407/10408,09670

Ref.	Tennant Part No.	Machine Serial Number	Description	Qty.
▽	77495	(000000-)	Valve, Hyd Control Man	1
1	79822	(000000-)	Spacer En	3
2	79786	(000000-)	Plunger En	3
3	79787	(000000-)	Spring En	3
4	79823	(000000-)	Plug Assy,Byd En	1
5	79788	(000000-)	Bushing En	3
6	79789	(000000-)	Cap Assembly En	3
7	79790	(000000-)	Plug Assembly En	1
8	79791	(000000-)	Poppet En	1
9	79792	(000000-)	Retaining Rng En	3
10	79793	(000000-)	Shim .035 Thk En	1
10	79798	(000000-)	Shim .015 Thk En	1
10	79799	(000000-)	Shim .010 Thk En	1
11	79794	(000000-)	Washer En	3
12	79795	(000000-)	Plug & O-Ring En	3
13	79824	(000000-)	Spring En	3
14	79797	(000000-)	Spring En	1
15	13904	(000000-)	Plug Gage #6	1
16	79812	(000000-)	Seal Kit, Vlv En	1
17	79820	(000000-)	Instr. Valve Repair Info	1

Fig. 26 – Hydraulic Manual Control Breakdown, 74285

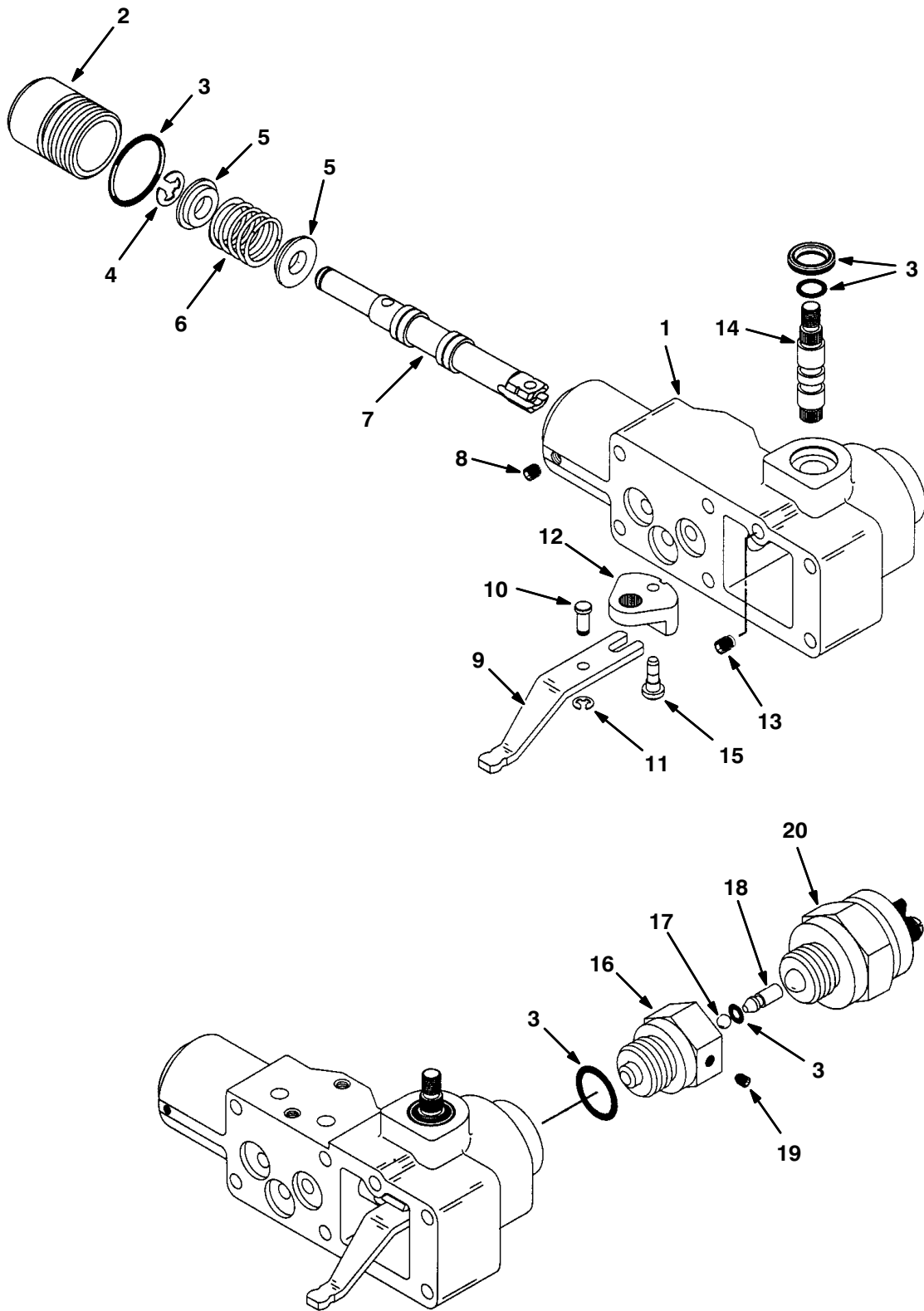

Fig. 26 – Hydraulic Manual Control Breakdown, 74285

Ref.	Tenant Part No.	Machine Serial Number	Description	Qty.
∇	74285	(000000–) Manual Control En	1
1	79777	(000000–) Housing,Control En	1
2	79755	(000000–) Plug En	1
3	79776	(000000–) Seal Kit,Cntrl En	1
4	79756	(000000–) Ring, Retaining En	1
5	79757	(000000–) Spring,Retainer En	2
6	79758	(000000–) Spring, Cntr En	1
7	79772	(000000–) Vlv Spool Wide En	1
8	79760	(000000–) Screw, Set En	1
9	79761	(000000–) Link, Feedback En	1
10	79762	(000000–) Dowel Pin En	1
11	79763	(000000–) Ring, Retaining En	1
12	79764	(000000–) Bell Crank En	1
13	79765	(000000–) Screw, Set En	1
14	79766	(000000–) Shaft, Input En	1
15	79767	(000000–) Pin, Headed En	1
16	79773	(000000–) Adaptor,Neutral En	1
17	79774	(000000–) Ball En	1
18	79778	(000000–) Pin, Cntrl Assy En	1
19	79760	(000000–) Screw, Set En	1
20	79775	(000000–) Switch,Lockout En	1

Fig. 27 – Hydraulic Manual Control Breakdown, 74273

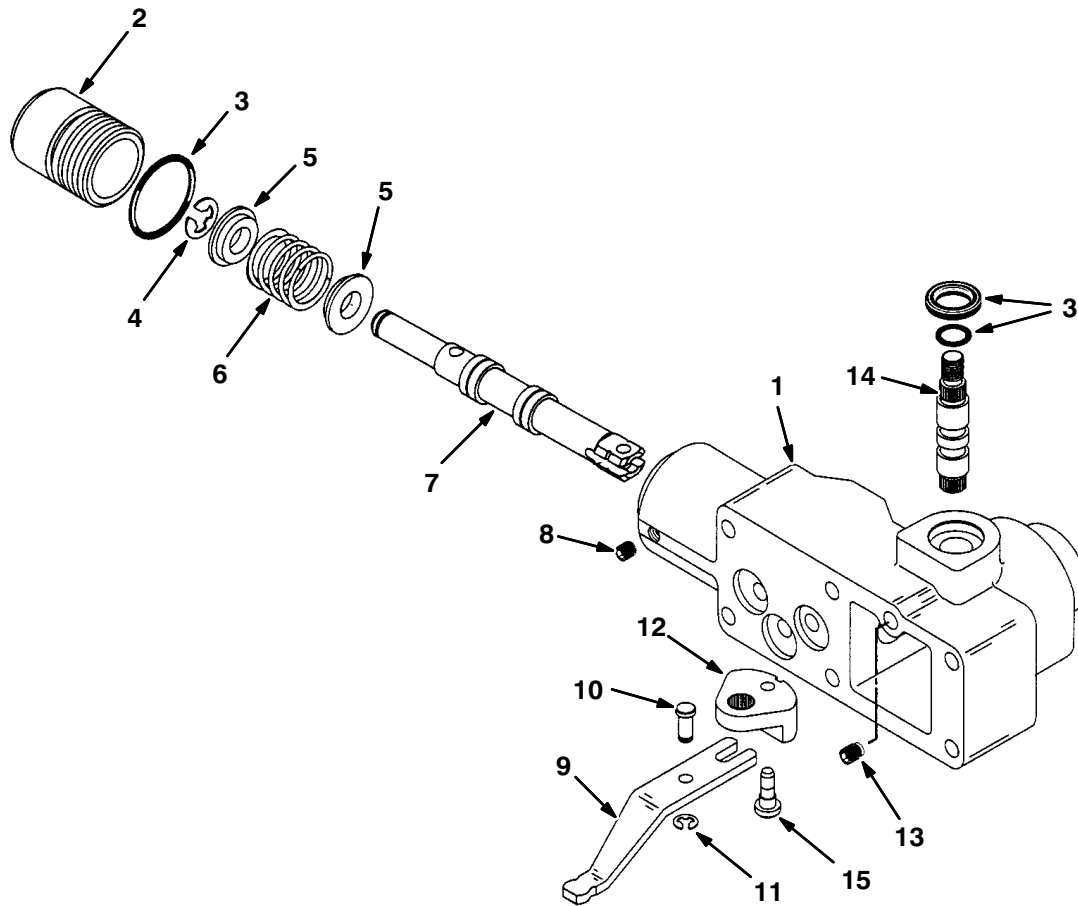
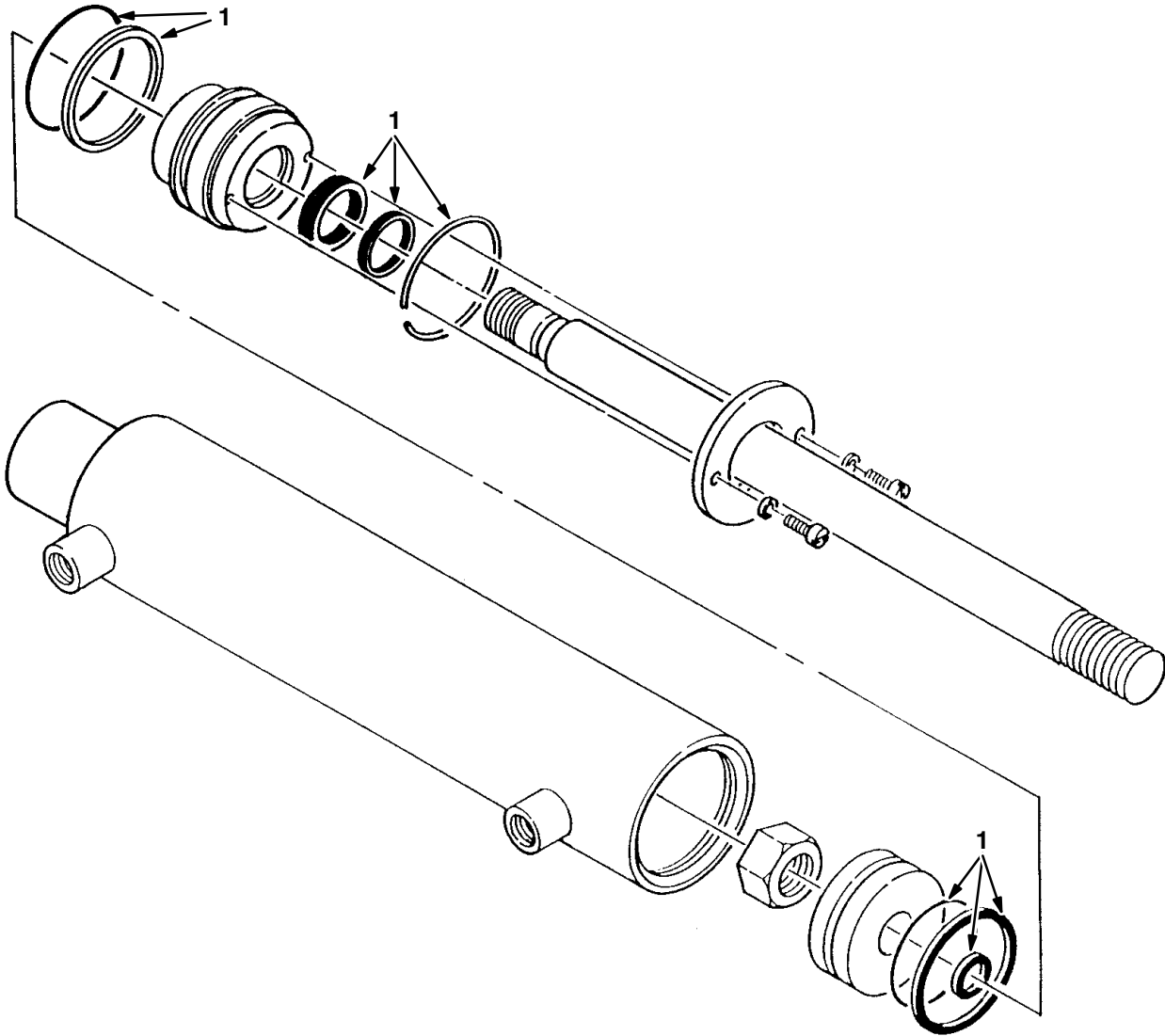

Fig. 27 – Hydraulic Manual Control Breakdown, 74273

Ref.	Tenant Part No.	Machine Serial Number	Description	Qty.
∇	74273	(000000–) Control, Manual	1
1	79754	(000000–) Housing,Control	1
2	79755	(000000–) Plug	1
3	79776	(000000–) Seal Kit,Cntrl	1
4	79756	(000000–) Ring, Retaining	1
5	79757	(000000–) Spring,Retainer	2
6	79758	(000000–) Spring, Cntr	1
7	79759	(000000–) Valve Spool	1
8	79760	(000000–) Screw, Set	1
9	79761	(000000–) Link, Feedback	1
10	79762	(000000–) Dowel Pin	1
11	79763	(000000–) Ring, Retaining	1
12	79764	(000000–) Bell Crank	1
13	79765	(000000–) Screw, Set	1
14	79766	(000000–) Shaft, Input	1
15	79767	(000000–) Pin, Headed	1

BREAKDOWN

Fig. 28 – Hydraulic Cylinder Breakdown, 53601



07913/07494

Ref.	Tennant Part No.	Machine Serial Number	Description	Qty.
▽	53601	(000000–) Cylinder, Hydraulic	1
1	04483	(000000–) Seal Kit	1

Fig. 29 – Hydraulic Cylinder Breakdown, 62975

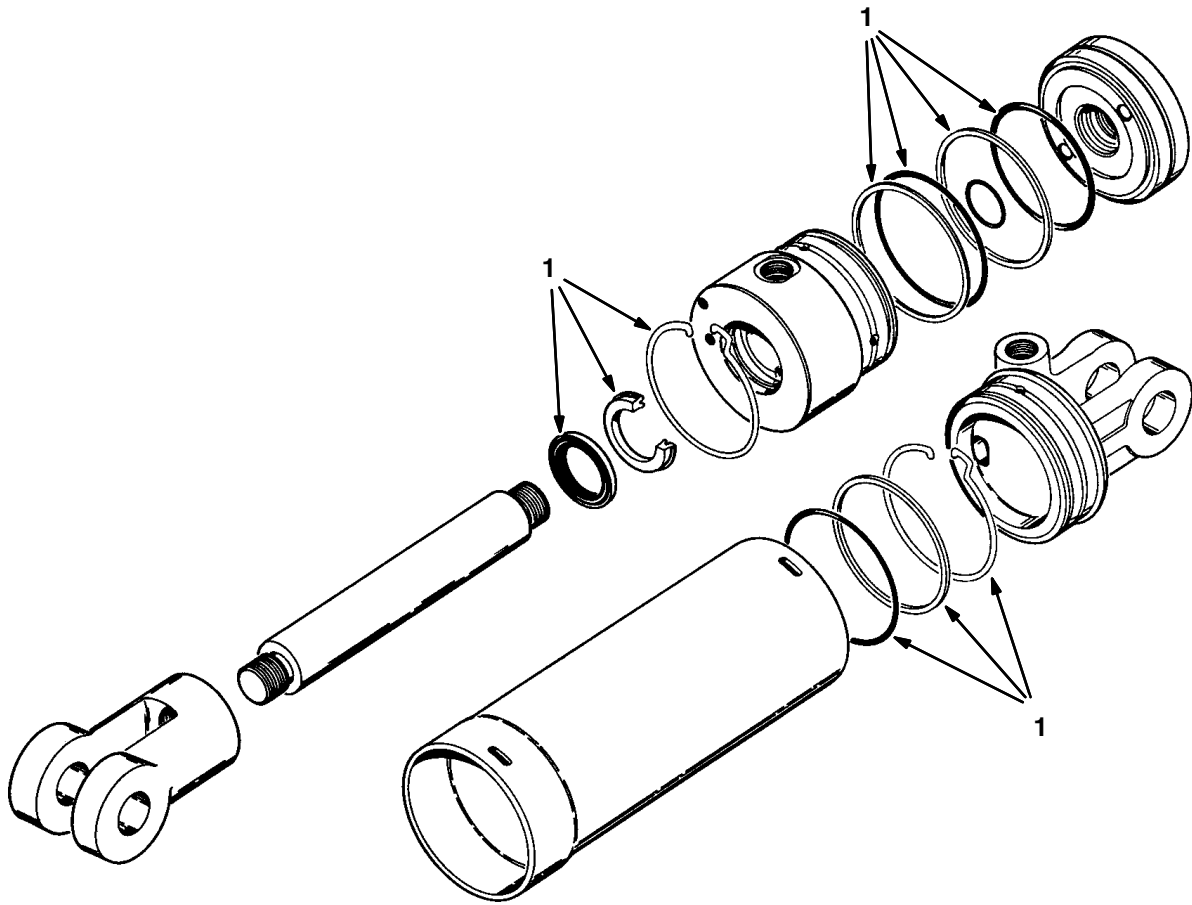

10403/10404

Ref.	Tennant Part No.	Machine Serial Number	Description	Qty.
▽	62975	(000000–) Cylinder, Hyd 4.0B 14.5S 2500	1
1040422	1 79783	(000000–) Seal Kit, Cyl	1
	2 79784	(000000–) Repair Info,Cyl En	1

Fig. 30 – Air Conditioner Breakdown, 77675

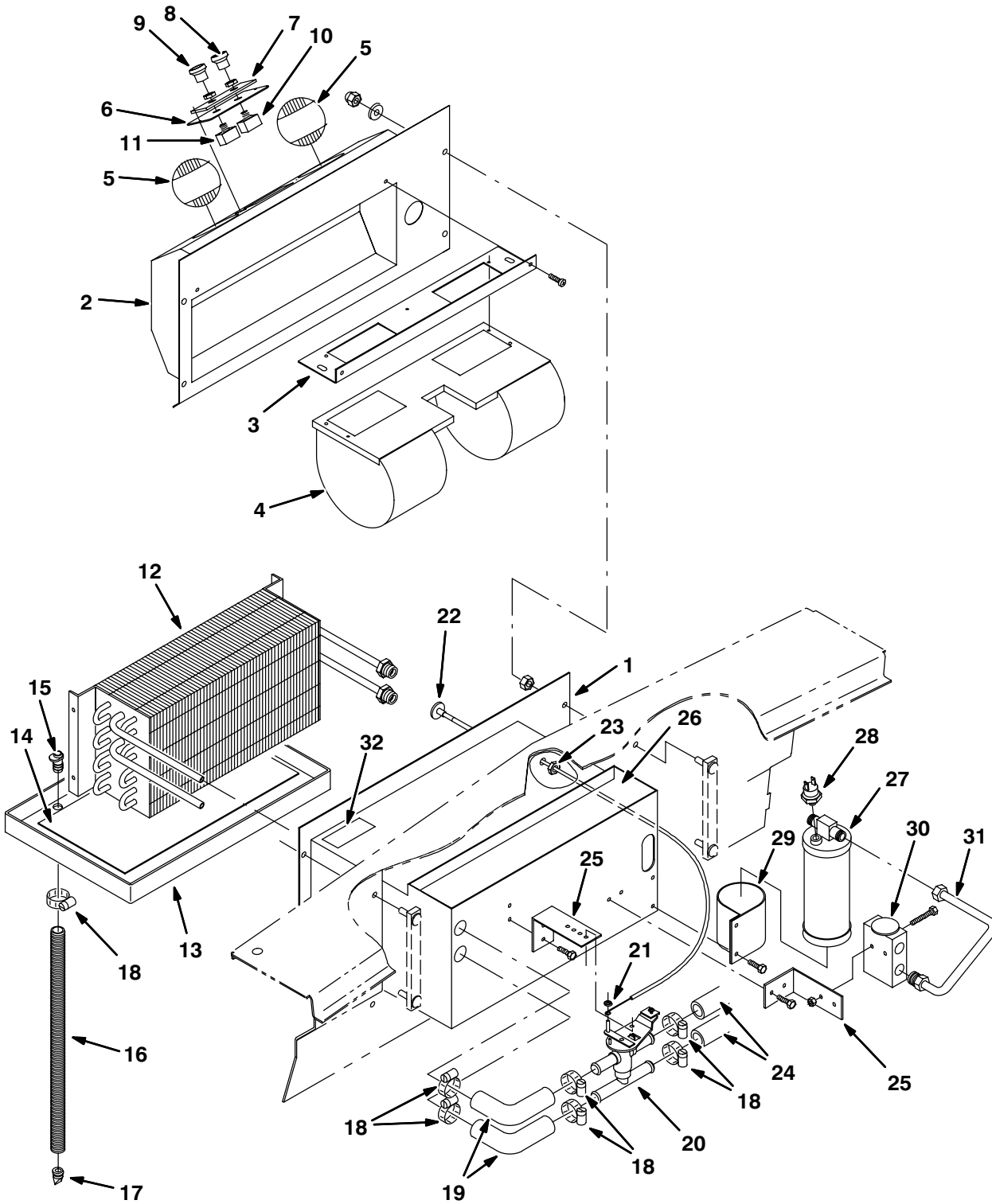

Fig. 30 – Air Conditioner Breakdown, 77675

Ref.	Tenant Part No.	Machine Serial Number	Description	Qty.
∇	77675	(000000–) Air Conditioner, A 134 (Repl. by 21270)	1
1	77825	(000000–) Box, A/C (Repl. by 21281)	1
2	77826	(000000–) Case Front Cover (Repl. by 21281)	1
3	79688	(000000–) Bracket, Blower Mount	1
4	55042	(000000–) Blower	1
5	77827	(000000–) Louver	2
6	79689	(000000–) Bracket, Switch, A/C	1
7	77833	(000000–) Face Plate Ac/Heat	1
8	77828	(000000–) Knob, Fan	1
9	77829	(000000–) Knob, Temp	1
10	77830	(000000–) Switch, Blower	1
11	77831	(000000–) Switch, Thermo	1
12	77839	(000000–) Core, Heating/Cooling	1
13	77849	(000000–) Drain Pan De	1
14	77848	(000000–) Water Screen Foam De	1
15	79695	(000000–) Drain Pan Tube De	2
16	77517	(000000–) Hose, A/C Drain	2
17	79698	(000000–) Valve, Check	2
18	77872	(000000–) Hose Clamp De	8
19	77846	(000000–) Hose Elbow 5/8 De	2
20	77841	(000000–) Water Valve	1
21	77842	(000000–) Valve, Push Nut Water	1
22	77835	(000000–) Cable, Bowden	1
23	79692	(000000–) Jamb Nut 7/16 Hex De	1
24	32151	(000000–) Heater Hose 72In De	2
25	79694	(000000–) Valve Mountng Brkt De	2
26	77847	(000000–) Foam Case Insul De	1
27	77843	(000000–) Dryer	1
28	77844	(000000–) Binary Press. Switch	1
29	77845	(000000–) Dryer Bracket De	1
30	77840	(000000–) Explansion Block	1
31	79697	(000000–) Alum.Dryer Line De	1
32	79699	(000000–) Decal	1
	77832	(000000–) Wire Harness	1

Fig. 31 – Air Conditioner Breakdown, 21270

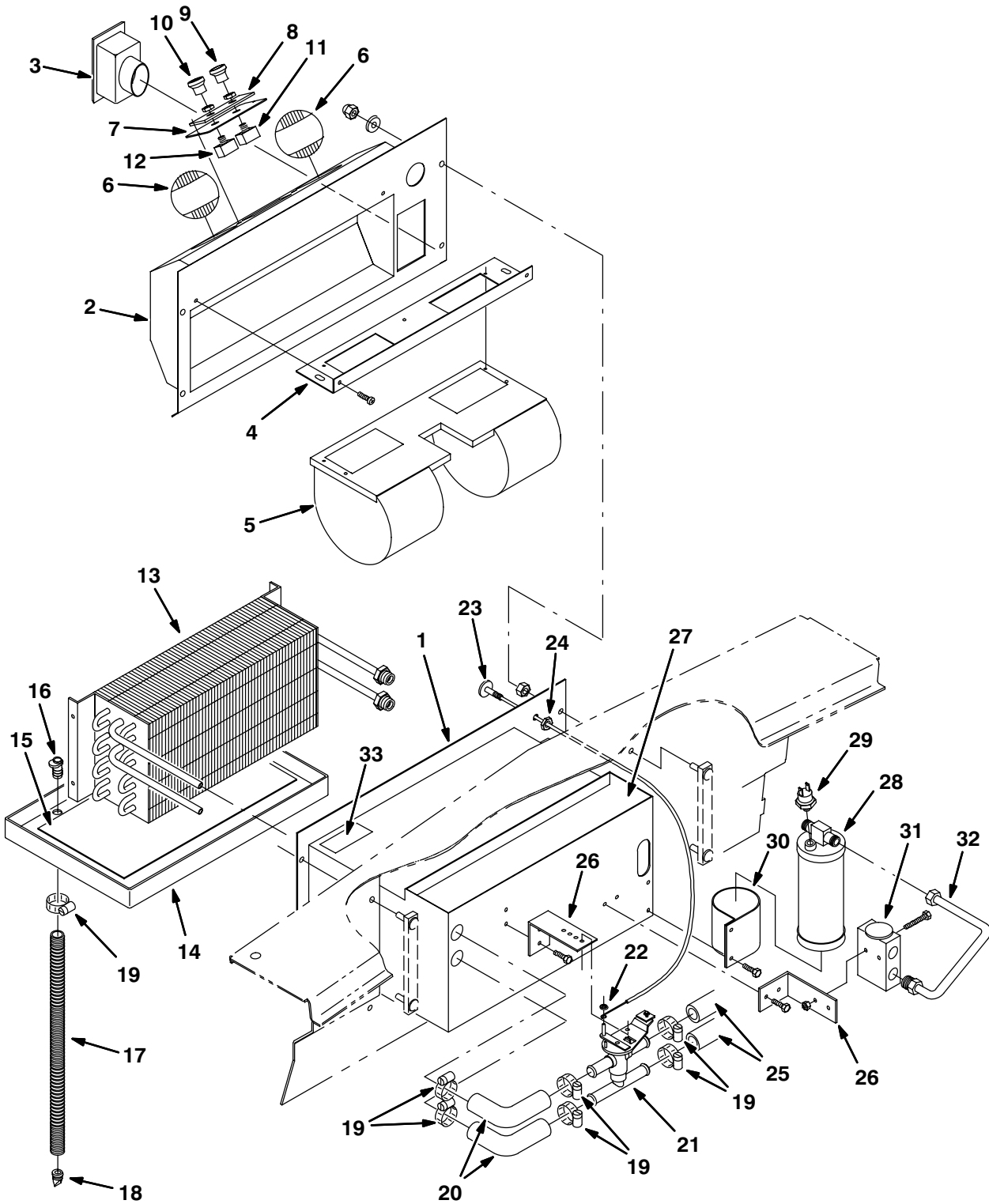

Fig. 31 – Air Conditioner Breakdown, 21270

Ref.	Tenant Part No.	Machine Serial Number	Description	Qty.
∇	21270	(000000–)	Air Conditioner 134R Recirc	1
1	21279	(000000–)	Box, A/C	1
2	21280	(000000–)	Cover, A/C	1
3	21272	(000000–)	Louver, Recirc	1
4	79688	(000000–)	Bracket, Blower Mount	1
5	55042	(000000–)	Blower	1
6	77827	(000000–)	Louver	2
7	79689	(000000–)	Bracket, Switch, A/C	1
8	77833	(000000–)	Face Plate Ac/Heat	1
9	77828	(000000–)	Knob, Fan	1
10	77829	(000000–)	Knob, Temp	1
11	77830	(000000–)	Switch, Blower	1
12	77831	(000000–)	Switch, Thermo	1
13	77839	(000000–)	Core, Heating/Cooling	1
14	77849	(000000–)	Drain Pan De	1
15	77848	(000000–)	Water Screen Foam De	1
16	79695	(000000–)	Drain Pan Tube De	2
17	77517	(000000–)	Hose, A/C Drain	2
18	79698	(000000–)	Valve, Check	2
19	77872	(000000–)	Hose Clamp De	8
20	77846	(000000–)	Hose Elbow 5/8 De	2
21	77841	(000000–)	Water Valve	1
22	77842	(000000–)	Valve, Push Nut Water	1
23	77835	(000000–)	Cable, Bowden	1
24	79692	(000000–)	Jamb Nut 7/16 Hex De	1
25	32151	(000000–)	Heater Hose 72In De	2
26	79694	(000000–)	Valve Mountng Brkt De	2
27	77847	(000000–)	Foam Case Insul De	1
28	77843	(000000–)	Dryer	1
29	77844	(000000–)	Binary Press. Switch	1
30	77845	(000000–)	Dryer Bracket De	1
31	77840	(000000–)	Explansion Block	1
32	79697	(000000–)	Alum.Dryer Line De	1
33	79699	(000000–)	Decal	1
	77832	(000000–)	Wire Harness	1

Fig. 32 – Heater/Pressurizer Breakdown, 74091

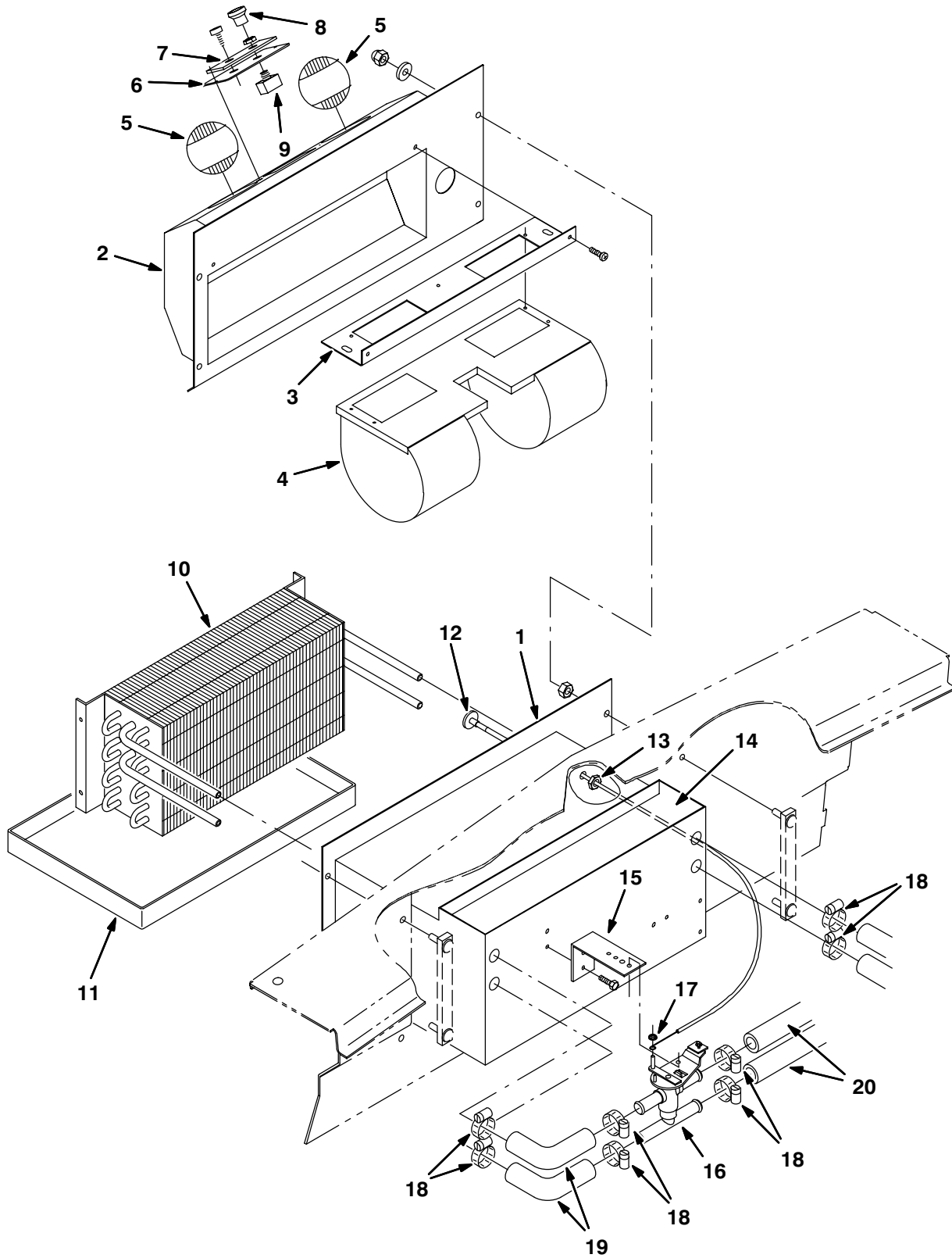

Fig. 32 – Heater/Pressurizer Breakdown, 74091

Ref.	Tenant Part No.	Machine Serial Number	Description	Qty.
∇	74091	(000000–) Heater, Pressurizer (Repl. by 21271)	1
1	77825	(000000–) Box, A/C	1
2	77826	(000000–) Case Front Cover	1
3	79688	(000000–) Bracket, Blower Mount	1
4	55042	(000000–) Blower	1
5	77827	(000000–) Louver	2
6	79690	(000000–) Switch Brkt Heat De	1
7	77834	(000000–) Face Plate Heat De	1
8	77828	(000000–) Knob, Fan	1
9	77830	(000000–) Switch, Blower	1
10	77839	(000000–) Core, Heating/Cooling	1
11	77849	(000000–) Drain Pan De	1
12	77835	(000000–) Cable, Bowden	1
13	79692	(000000–) Jamb Nut 7/16 Hex De	1
14	77847	(000000–) Foam Case Insul De	1
15	79694	(000000–) Valve Mountng Brkt De	1
16	77841	(000000–) Water Valve	1
17	77842	(000000–) Valve, Push Nut Water	1
18	77872	(000000–) Hose Clamp De	8
19	77846	(000000–) Hose Elbow 5/8 De	2
20	32151	(000000–) Heater Hose 72In De	2
	77832	(000000–) Wire Harness	1

Fig. 33 – Heater/Pressurizer Breakdown, 21271

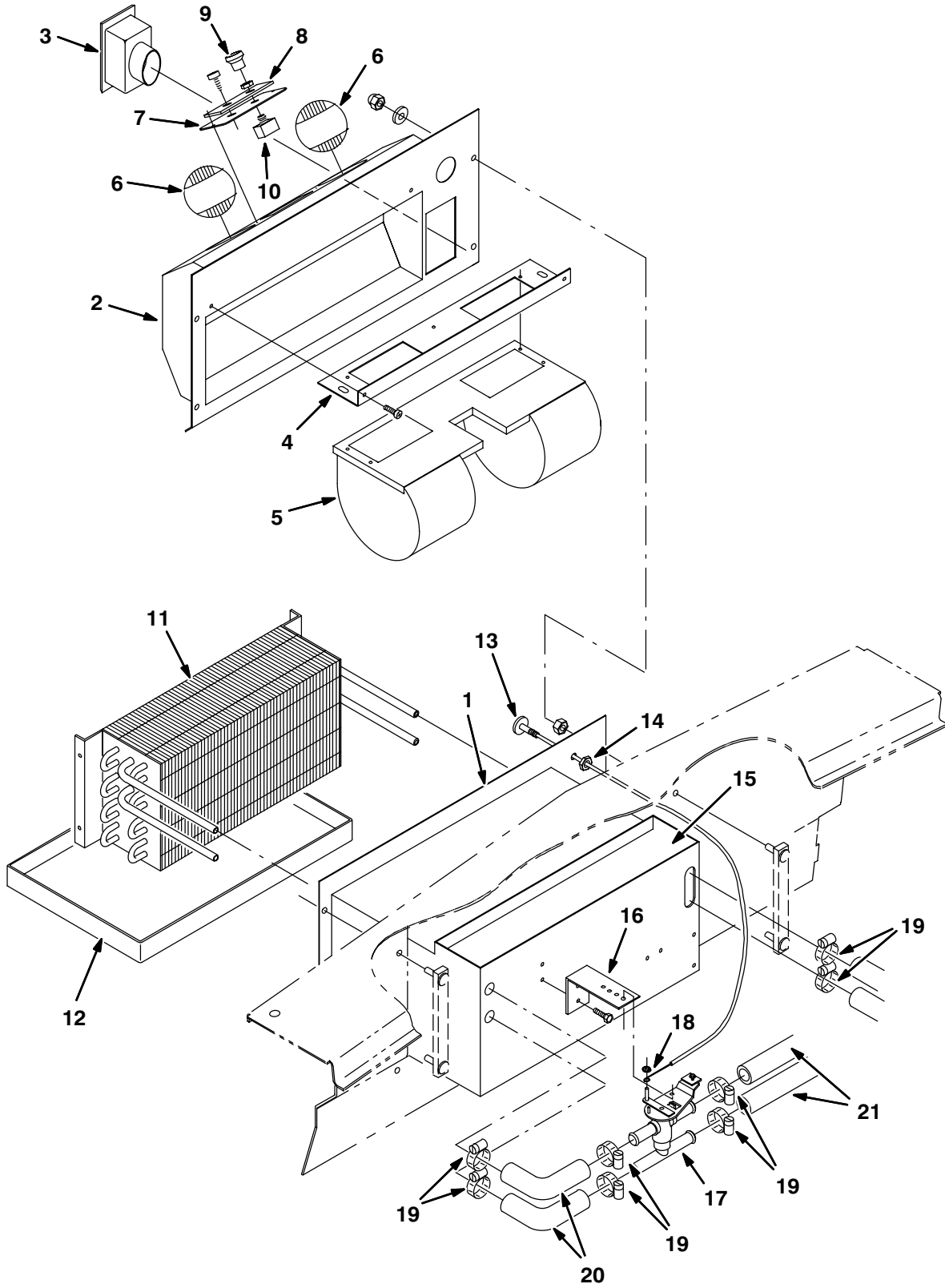

Fig. 33 – Heater/Pressurizer Breakdown, 21271

Ref.	Tenant Part No.	Machine Serial Number	Description	Qty.
∇	21271	(000000–) Heater, Pressurizer	1
1	21279	(000000–) Box, A/C	1
2	21280	(000000–) Cover, A/C	1
3	21272	(000000–) Louver, Recirc	1
4	79688	(000000–) Bracket, Blower Mount	1
5	55042	(000000–) Blower	1
6	77827	(000000–) Louver	2
7	79690	(000000–) Switch Brkt Heat De	1
8	77834	(000000–) Face Plate Heat De	1
9	77828	(000000–) Knob, Fan	1
10	77830	(000000–) Switch, Blower	1
11	77839	(000000–) Core, Heating/Cooling	1
12	77849	(000000–) Drain Pan De	1
13	77835	(000000–) Cable, Bowden	1
14	79692	(000000–) Jamb Nut 7/16 Hex De	1
15	77847	(000000–) Foam Case Insul De	1
16	79694	(000000–) Valve Mountng Brkt De	1
17	77841	(000000–) Water Valve	1
18	77842	(000000–) Valve, Push Nut Water	1
19	77872	(000000–) Hose Clamp De	8
20	77846	(000000–) Hose Elbow 5/8 De	2
21	32151	(000000–) Heater Hose 72In De	2
	77832	(000000–) Wire Harness	1

SECTION 5

CONTENTS

	PAGE
Fig. 1 – Engine Block Group	5-2
Fig. 2 – Gaskets Group	5-4
Fig. 3 – Cylinder Head Group	5-6
Fig. 4 – Cylinder Front Cover Group	5-7
Fig. 5 – Auxiliary Driveshaft	5-8
Fig. 6 – Oil Pan Group	5-10
Fig. 7 – Crankshaft Group	5-12
Fig. 8 – Manifolds Group	5-14
Fig. 9 – Camshaft, Sprocket Group	5-15
Fig. 10 – Valves, Rocker Arm Cover Group	5-16
Fig. 11 – Piston, Connecting Rod Group	5-18
Fig. 12 – Starter Breakdown	5-20
Fig. 13 – Water Pump, Thermostat Group	5-22
Fig. 14 – Ignitions Group	5-23

Fig. 1 – Engine Block Group

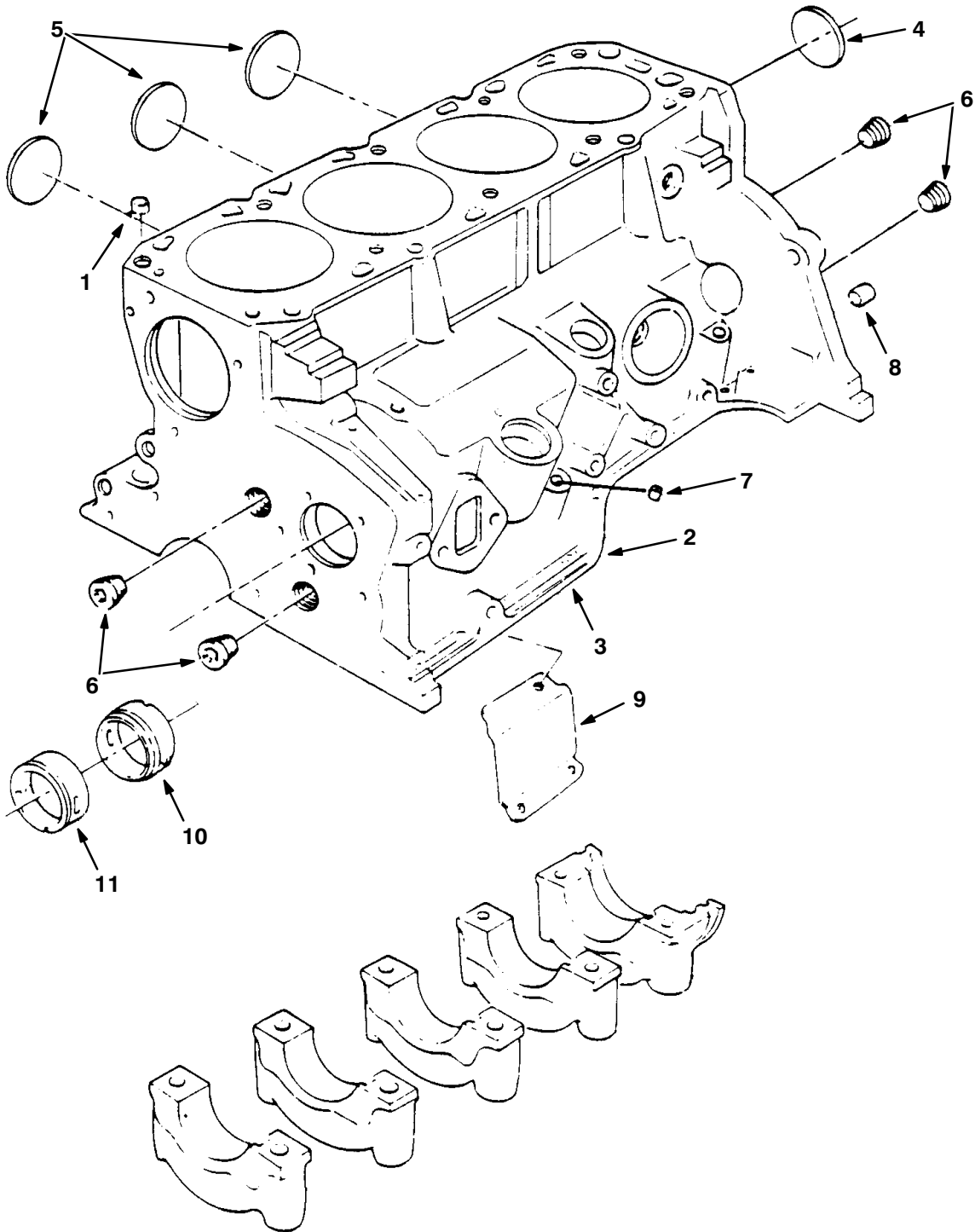

Fig. 1 – Engine Block Group

Ref.	Tennant Part No.	Ford Part Number	Description	Qty.
1	73958	D4FZ-6A008-A	Dowel – Cylinder Head to Block	2
2	74541	E9ZZ-6009-B	Cylinder Assy – W/1 Piece Pan Gasket	1
3	60802	E7SZ-6010-A	Block Assy – W/1 Piece Pan Gasket	1
4	73920	C5AZ-6026-H	Plug	1
4	73921	C5AZ-6026-J	Plug, Standard – 2.078 OD	1
5	73922	C8AZ-6026-D	Plug – 0.060 O/S	–
5	73974	D7AZ-6026-A	Plug – 1.50 Cup	3
6	36268	87837-S	Plug – 1/4 NPT	–
6	73917	87838-S101	Plug – 3/8 NPT	–
7	73913	352532-S	Plug – 3/8 Cup	–
8	73975	D7BZ-6397-A	Dowel – Flywheel Housing to Block	2
9	74519	E5ZZ-6A630-A	Baffle – Cylinder Block Ventilation	1
10	73961	D4FZ-6A738-A	Bearing – Rear – Standard	1
10	73962	D4FZ-6A738-B	Bearing – Rear 0.015 U/S	–
11	73963	D4FZ-6A753-A	Bearing – Front – Standard	1
11	73964	D4FZ-6A753-B	Bearing – Front 0.015 U/S	–

Fig. 2 – Gaskets Group

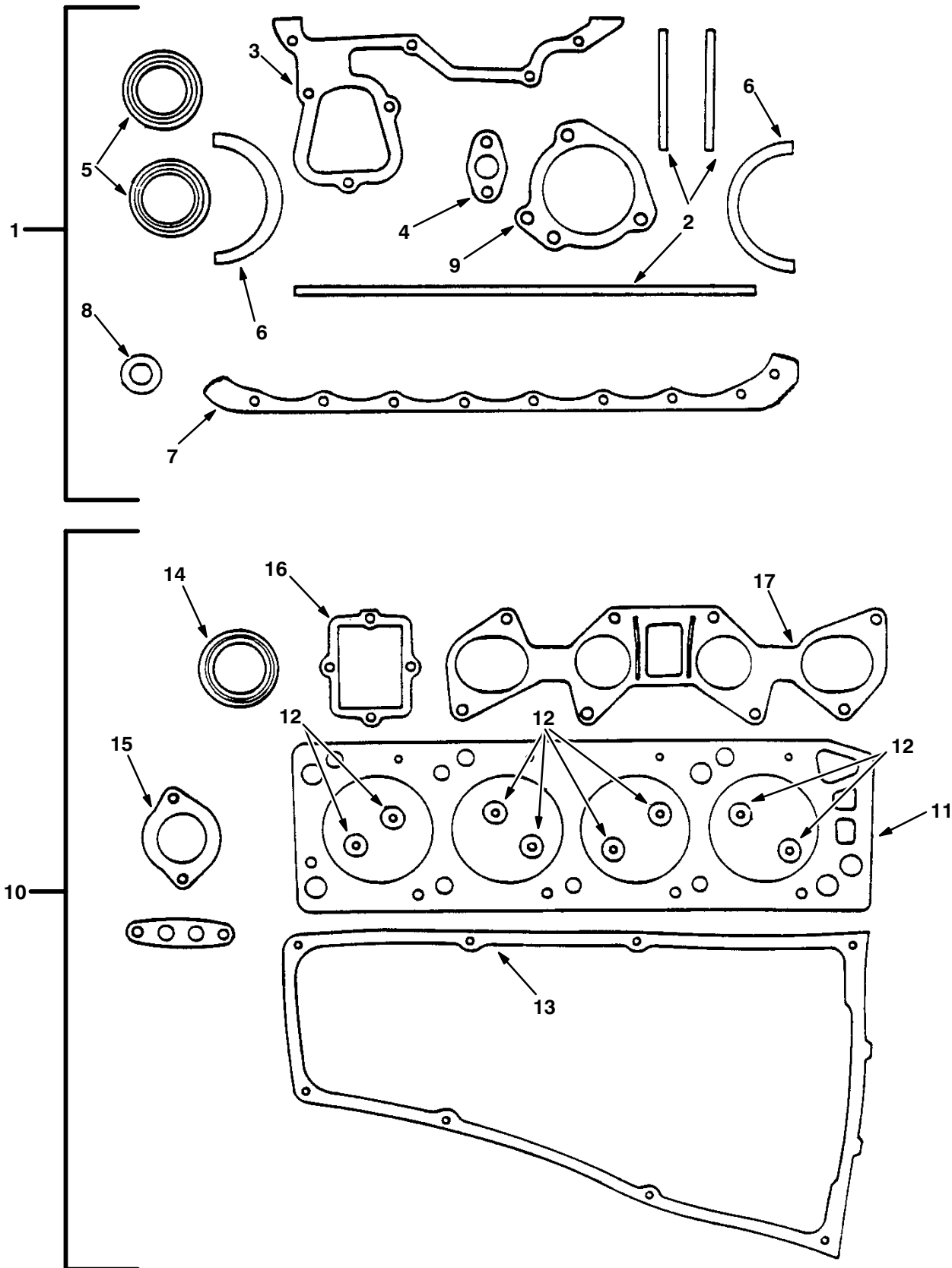
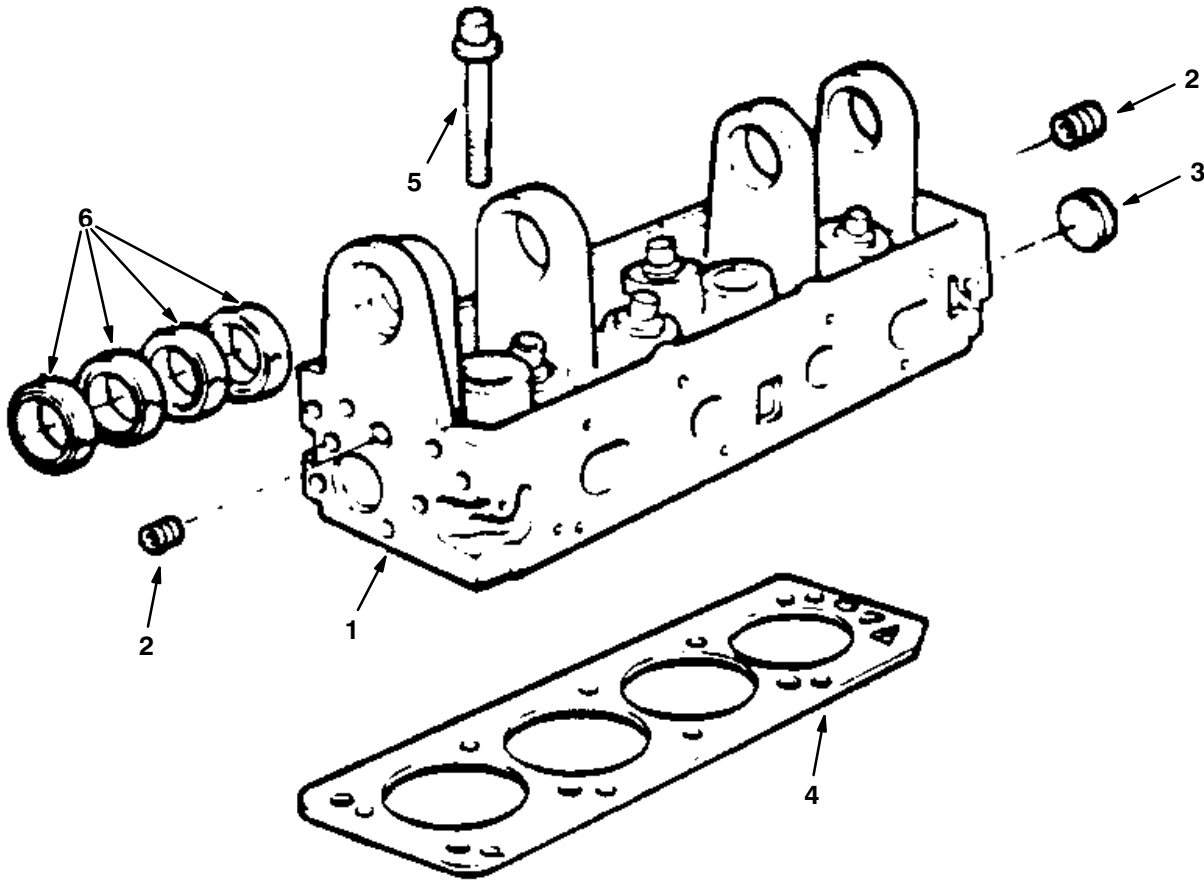

Fig. 2 – Gaskets Group

	Ref.	Tennant Part No.	Ford Part Number	Description	Qty.
∇	1	60807	E6ZZ-6E078-B	Gasket Kit, Lower	1
	2	73924	D42E-6E009-BB	Seal – Front Cover	2
	2	60804	D4FZ-6020-A	Gasket – Outer	1
	3	60803	D4FZ-6020-B	Gasket – Front Cover	1
	4	74537	E8ZZ-8507-A	Gasket	1
	5	60833	E8ZZ-6700-A	Seal – Front	2
	6	60834	E5ZZ-6701-A	Seal – Rear – 1 Piece	1
	7	74559	F1ZZ-6710-A	Gasket – Oil Pan – One Piece	1
	8	74543	F3DZ-6754-A	Gasket – Drain Plug	1
	9	74539	E8ZZ-8507-A	Gasket – Water Pump	1
∇	10	60808	E5ZZ-6079-E	Gasket Kit, Valve Grind	1
	11	74513	E8ZZ-6051-A	Gasket	1
	12	73953	D4FZ-6571-A	Seal – Valve Stem – Standard	8
	13	73995	F1ZZ-6700-A	Gasket	1
	14	73957	D4FZ-6700-A	Seal	1
	15	74510	RG-565	Gasket	1
	16	73992	D8FZ-9E436-B	Gasket – Intake Manifold Cover	1
	17	73971	D4FZ-9441-A	Gasket – Intake Manifold	1
	17	74511	E59Z-9439-A	Gasket – Intake Manifold	1

Fig. 3 – Cylinder Head Group



06832/06773

Ref.	Tennant Part No.	Ford Part Number	Description	Qty.
1	60805	E7JE-6049-DA	Head	1
2	36268	87837-S	Plug – 1/4 NPT	2
3	73974	D7AZ-6026-A	Plug – 1.50 Cup	1
4	60806	E8ZZ-6051-A	Gasket – Cylinder Head	1
5	73927	F3ZZ-6065-A	Bolt – M12 – 1.75 x 100	10
6	73936	D4FZ-6261-B	Bearing Camshaft – .016 U/S	–
6	60817	D4FZ-6261-C	Bearing Camshaft – Standard	4

Fig. 4 – Cylinder Front Cover Group

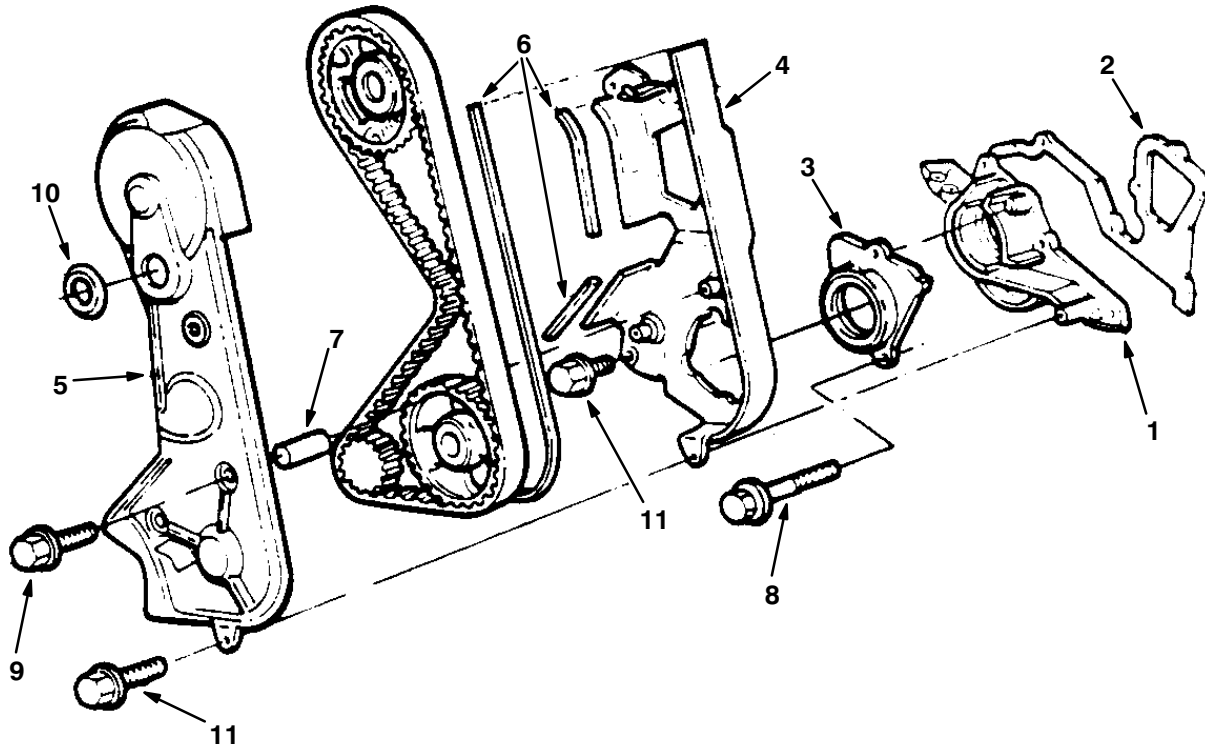

06833/06772

Ref.	Tennant Part No.	Ford Part Number	Description	Qty.
1	74524	E6ZZ-6019-A	Cover – Lower – Metal	1
2	60803	D4FZ-6020-B	Gasket – Front Cover	1
3	73926	D4FZ-6019-B	Cover – Upper – Metal	1
4	74506	E3ZZ-6019-B	Cover – Inner – Plastic	1
5	73999	E3ZZ-6019-A	Cover – Outer – Plastic	1
6	60804	D4FZ-6020-A	Gasket – Outer	1
7	73968	D4FZ-6K291-A	Spacer – Cover	2
8	74546	N602529-S2	Bolt – M6X20	4
9	74534	E7ZZ-6E008-A	Stud – M8X49	1
9	74555	N801688-S2	Bolt – M6X17	1
10	74536	E8ZZ-6026-A	Plug – Hole in Front Cover	1
11	74555	N801688-S2	Bolt – M6X17	3

Fig. 5 – Auxiliary Driveshaft

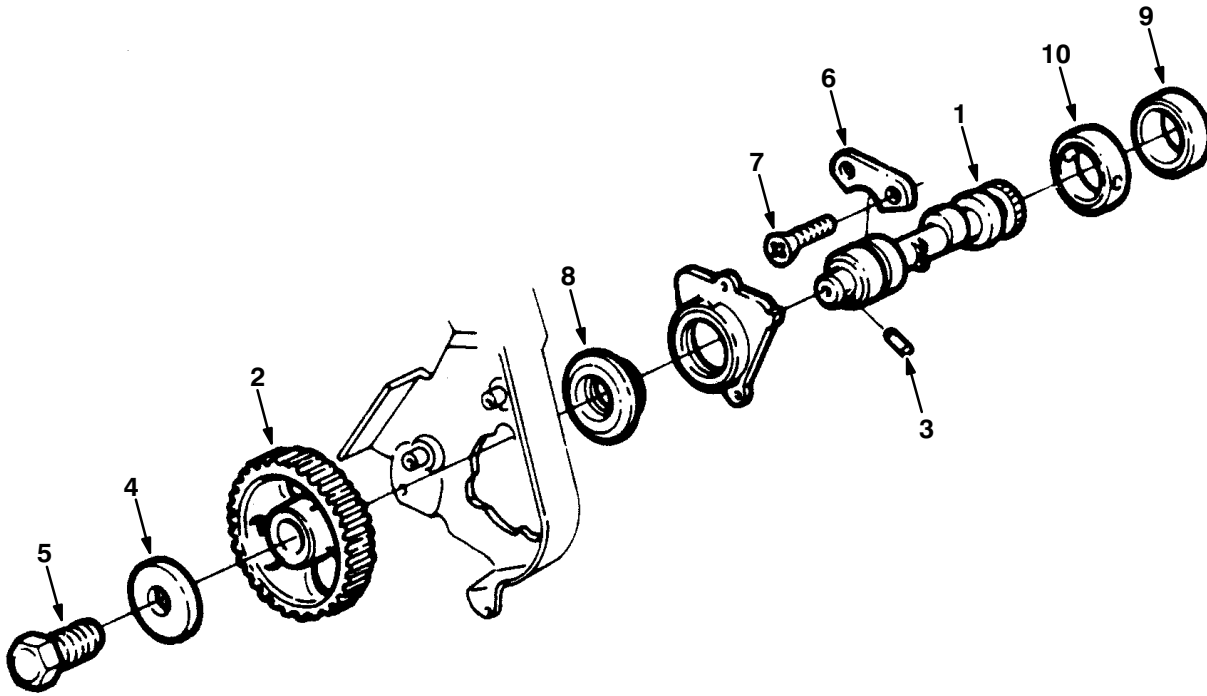

Fig. 5 – Auxiliary Driveshaft

Ref.	Tennant Part No.	Ford Part Number	Description	Qty.
1	74560	E4FZ-6A739-A	Shaft	1
2	60816	D4FZ-6256-A	Sprocket	1
3	73915	373118-S	Pin	1
4	74561	D4FZ-6278-B	Washer	1
5	74562	N601313-S100	Bolt – M6X12	1
6	73954	D4FZ-6613-A	Plate	1
7	74548	N604465-S	Screw and Washer	2
8	60833	E8ZZ-6700-A	Seal – Front	1
9	73961	D4FZ-6A738-A	Bearing – Rear – Standard	1
	73962	D4FZ-6A738-B	Bearing – Rear .015 U/S	–
10	73963	D4FZ-6A753-A	Bearing – Front – Standard	1
	73964	D4FZ-6A753-B	Bearing – Front – .015 U/S	–

Fig. 6 – Oil Pan Group

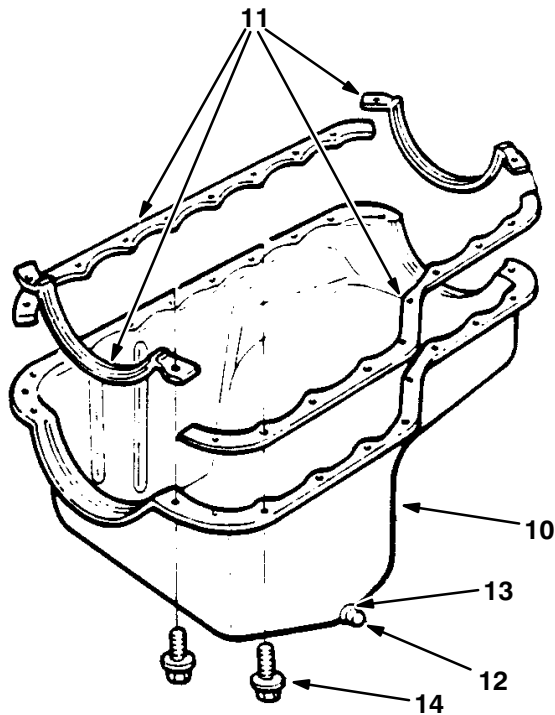
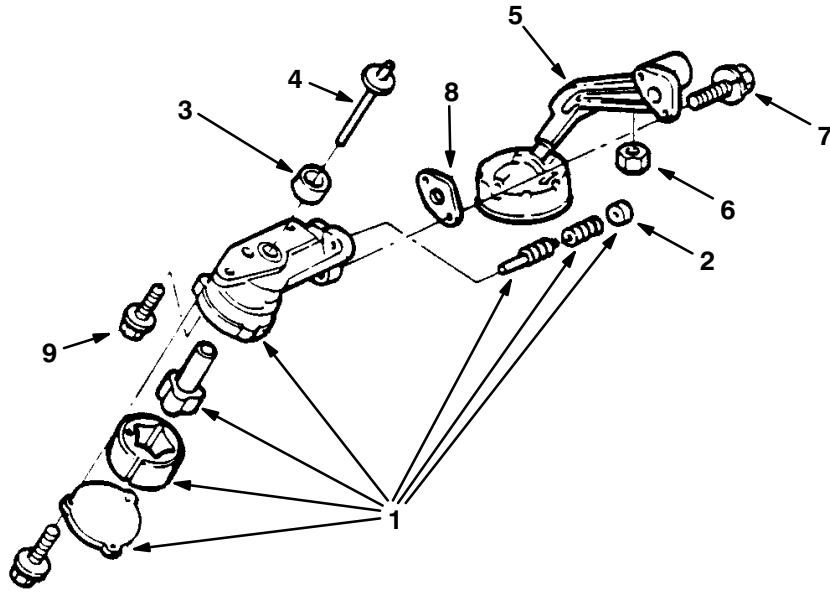

Fig. 6 – Oil Pan Group

	Ref.	Tennant Part No.	Ford Part Number	Description	Qty.
∇	1	60832	D5FZ-6600-A	Pump	1
	2	73919	C2OZ-6A616-A	Plug – Oil Pump Relief Valve	1
	3	74551	N800059-S	Dowel – 18.3x10.0 – Oil Pump To Block	1
	4	73960	D4FZ-6A618-A	Shaft Assembly – Oil Pump Intermediate	1
	5	74507	E3ZZ-6622-A	Screen, Tube, and Cover Assy – Oil Pump	1
	6	74522	E620454-S72	Nut – M10	1
	7	74547	N602551-S2	Screw and Washer – M8X30	2
	8	74537	E8ZZ-6626-A	Gasket – Oil Pump To Pick Up	1
	9	73956	D4FZ-6638-A	Screw and Washer – M8X25	2
∇	10	74525	E7RY-6675-B	Pan Assembly – Oil – 1 Piece Pan Gasket	1
		74520	E5ZZ-6A674-A	Reinforcement – Oil Pan Flange	1
		74521	E5ZZ-6A674-B	Reinforcement – Oil Pan Flange	1
	11	74559	F1ZZ-6710-A	Gasket – Oil Pan – One Piece	1
∇	12	74512	F3DZ-6730-A	Plug – Engine Oil Drain	1
	13	74543	F3DZ-6734-A	Gasket – Drain Plug	1
	14	74556	N804660-S2	Bolt – M6x27.5	–

Fig. 7 – Crankshaft Group

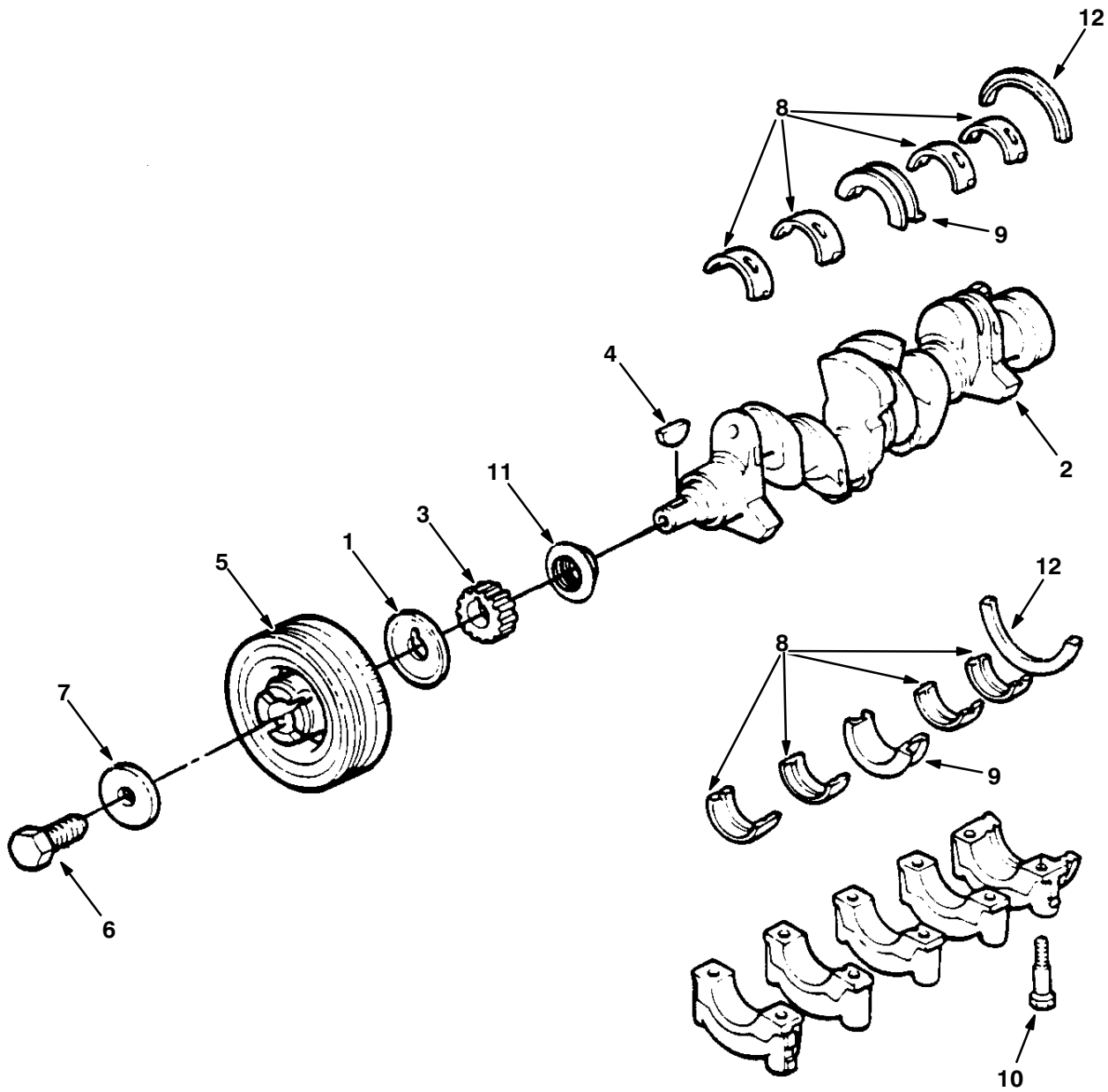
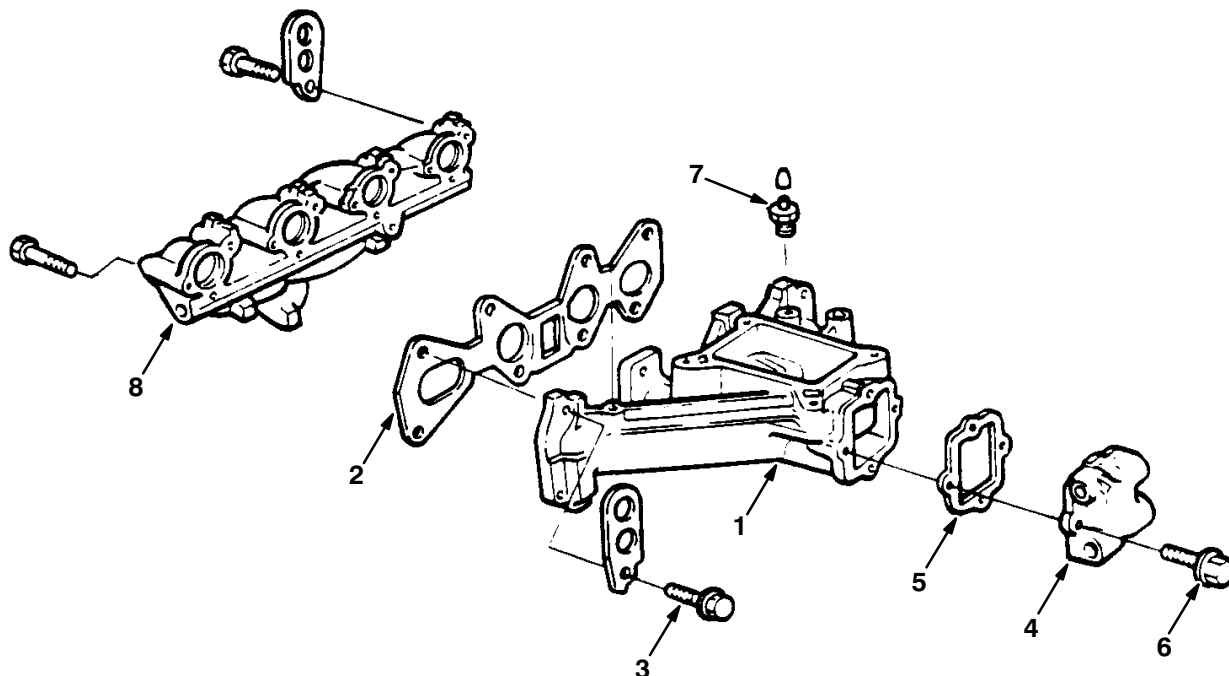

Fig. 7 – Crankshaft Group

Ref.	Tennant Part No.	Ford Part Number	Description	Qty.
1	73969	D4FZ-6K297-B	Guide – Timing Belt	1
2	60819	E2ZZ-6303-A	Use with 1 Piece Rear Seal	1
3	74540	E9TZ-6306-A	Sprocket	1
4	73966	D4FZ-6B316-A	Key – Sprocket To Crankshaft	1
5	74508	E3ZZ-6A312-A	Triple Sheave	1
6	73959	D4FZ-6A340-A	Bolt – M14x1.5x40 – Pulley To Crankshaft	1
7	73951	D4FZ-6378-A	Washer – M15 – Pulley To Crankshaft	1
8	60821	D4FZ-6333-A	Main Bearing – Standard Red	8
8	60822	D4FZ-6333-B	Main Bearing – Standard Blue	–
8	73938	D4FZ-6333-C	Main Bearing – 0.002 U/S	–
8	73939	D4FZ-6333-D	Main Bearing – 0.010 U/S	–
8	73940	D4FZ-6333-E	Main Bearing – 0.020 U/S	–
8	73941	D4FZ-6333-F	Main Bearing – 0.030 U/S	–
9	60823	D4FZ-6337-A	Thrust Bearing – Upper Standard Red	1
9	60824	D4FZ-6337-B	Thrust Bearing – Upper Standard Blue	–
9	73942	D4FZ-6337-C	Thrust Bearing – Upper 0.002 U/S	–
9	73943	D4FZ-6337-D	Thrust Bearing – Upper 0.010 U/S	–
9	73944	D4FZ-6337-E	Thrust Bearing – Upper 0.020 U/S	–
9	73945	D4FZ-6337-F	Thrust Bearing – Upper 0.030 U/S	–
9	60825	D4FZ-6337-G	Thrust Bearing – Lower Standard Red	1
9	60826	D4FZ-6337-H	Thrust Bearing – Lower Standard Blue	–
9	73946	D4FZ-6337-J	Thrust Bearing – Lower 0.002 U/S	–
9	73947	D4FZ-6337-K	Thrust Bearing – Lower 0.010 U/S	–
9	73948	D4FZ-6337-L	Thrust Bearing – Lower 0.020 U/S	–
9	73949	D4FZ-6337-M	Thrust Bearing – Lower 0.030 U/S	–
10	73914	356214-S8	Washer	1
10	73950	D4FZ-6345-A	Bolt – M12X1.75X80	9
10	74516	E5ZZ-6345-A	Stud – M12-M10X109	1
11	60833	E8ZZ-6700-A	Seal – Front	1
12	60834	E5ZZ-6701-A	Seal – Rear – 1 Piece	1

Fig. 8 – Manifolds Group



06836/06781

Ref.	Tennant Part No.	Ford Part Number	Description	Qty.
1	73994	E3TZ-9424-A	Manifold, Intake	1
2	73998	E3TZ-9439-A	Gasket – Intake Manifold	1
2	74511	E59Z-9439-A	Gasket – Intake Manifold	1
3	74553	N801424-S36	Stud – M8-M6X47.1	1
3	74554	N801427-S2	Bolt – M8X29	7
4	73925	D4FZ-9E434-A	Cover – Intake Manifold	1
5	73992	D8FZ-9E436-B	Gasket – Intake Manifold Cover	1
6	74546	N602529-S2	Bolt – M6X20	4
7	74527	E7TZ-9A474-C	Fitting – Vacuum	1
8	74509	E5ZZ-9430-A	Manifold, Exhaust	1

Fig. 9 – Camshaft, Sprocket Group

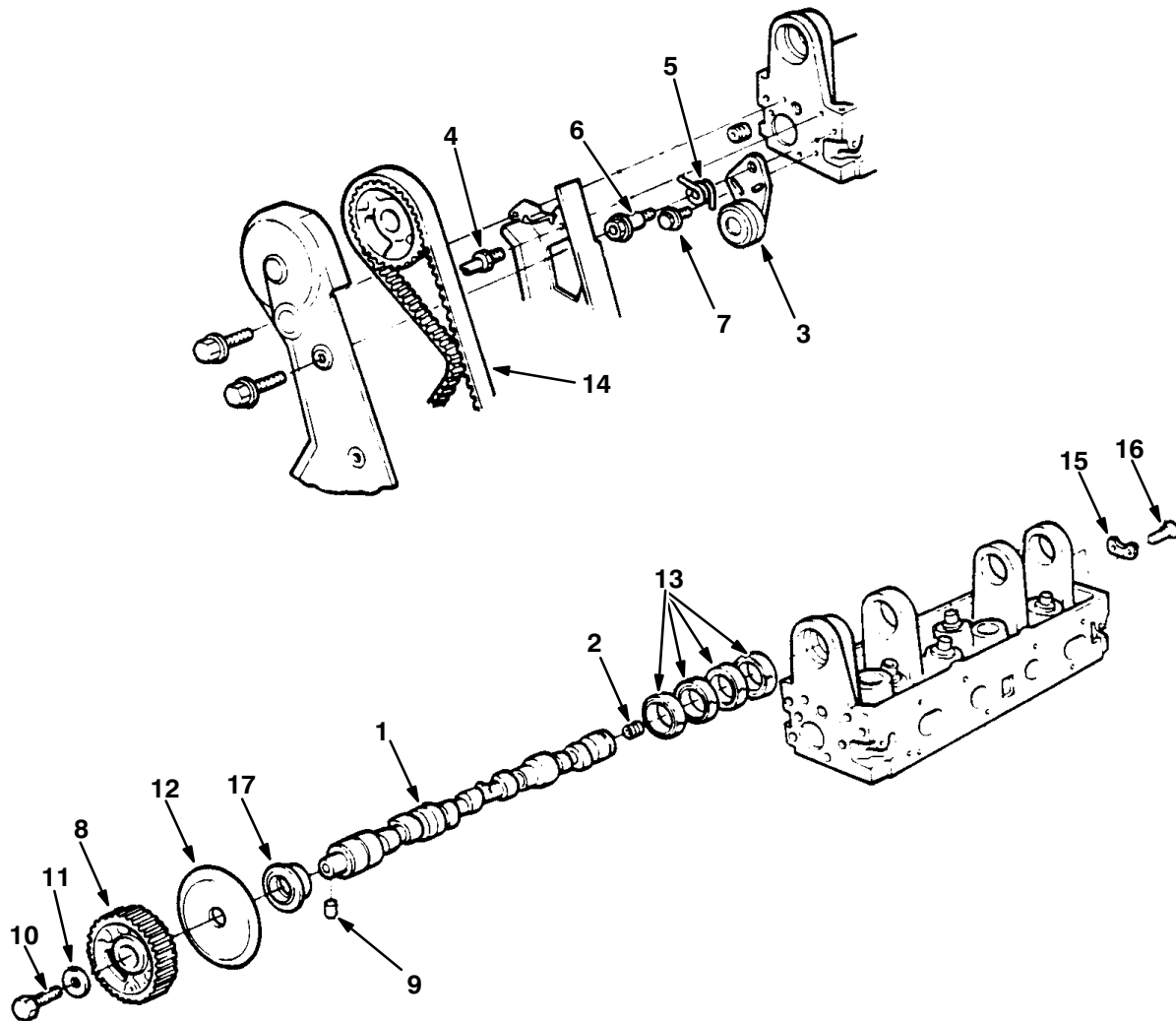

06837/06774

Ref.	Tennant Part No.	Ford Part Number	Description	Qty.
1	60815	E5ZZ-6250-C	Camshaft	1
2	36268	87837-S	Plug – 1/4 NPT	1
3	73967	D4FZ-6K254-A	Tensioner Assembly	1
4	74534	E7ZZ-6E008-A	Stud – M8X49	1
5	73970	D4FZ-6L273-A	Spring – Tensioner	1
6	73983	E9TZ-6K282-A	Bolt – Tensioner Spring	1
7	74552	N800112-S2	Bolt – Tensioner To Head	1
8	60816	D4FZ-6256-A	Sprocket	1
9	73915	373118-S	Pin	1
10	74545	N600414-S100	Bolt – M12X45 – Sprocket to Camshaft	1
11	73937	D4FZ-6278-A	Washer – Sprocket to Camshaft	1
12	73965	D4FZ-6B260-A	Guide – Timing Belt	1
13	73936	D4FZ-6261-B	Bearing Camshaft – 0.016 U/S	–
13	60817	D4FZ-6261-C	Bearing Camshaft – Standard	4
14	60818	E5ZZ-6268-A	Belt, Timing 129 Teeth	1
15	73954	D4FZ-6613-A	Plate	1
16	74548	N604465-S	Screw and Washer – M6X12	2
17	60833	E8ZZ-6700-A	Seal – Front	1

Fig. 10 – Valves, Rocker Arm Cover Group

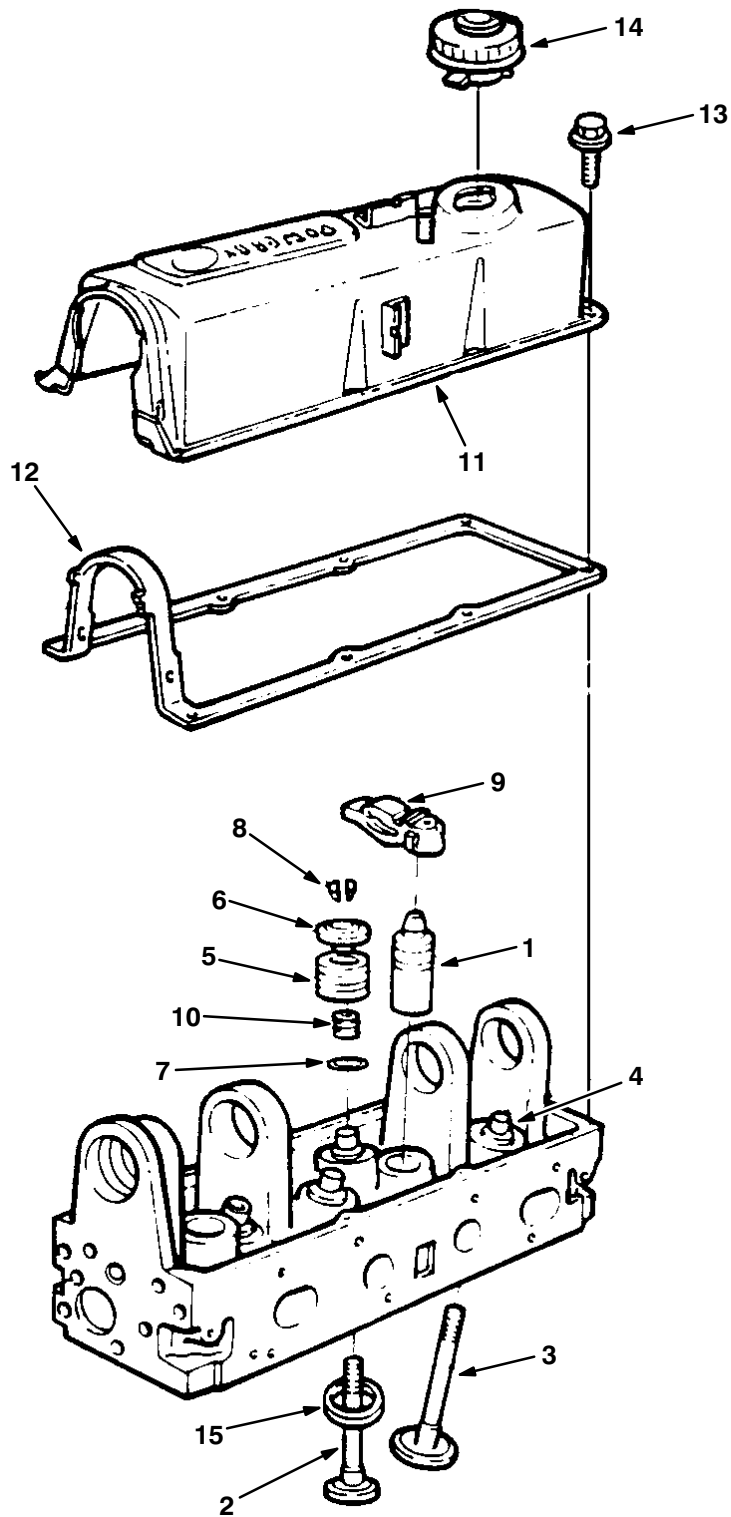

Fig. 10 – Valves, Rocker Arm Cover Group

Ref.	Tennant Part No.	Ford Part Number	Description	Qty.
1	60827	D6FZ-6500-A	Tappet Valve Standard	8
1	73973	D6FZ-6500-B	Tappet Valve 0.020 O/S	-
2	60828	E5TZ-6505-F	Valve, Exhaust Standard	-
2	74514	E5TZ-6505-G	Valve, Exhaust 0.015 O/S	-
2	74515	E5TZ-6505-H	Valve, Exhaust 0.030 O/S	-
3	60829	E5ZZ-6507-D	Valve, Intake Standard	4
3	74517	E5ZZ-6507-E	Valve, Intake 0.015 O/S	-
3	74518	E5ZZ-6507-F	Valve, Intake 0.030 O/S	-
4	73952	D4FZ-6510-A	Bushing	-
5	60830	E4ZZ-6513-A	Spring	8
6	60831	E43Z-6514-A	Retainer	8
7	73918	B3Q-6515-A	Shim – 0.030 Thick – 1.0 ID	-
8	60847	DOAZ-6518-A	Key	16
9	73990	D8FZ-6564-A	Arm	8
10	74528	E7ZZ-6571-A	Seal, Intake – Standard	-
10	74529	E7ZZ-6571-B	Seal, Exhaust – Standard	-
10	74530	E7ZZ-6571-C	Seal, Intake – 0.015 O/S	-
10	74531	E7ZZ-6571-D	Seal, Intake – 0.030 O/S	-
10	74532	E7ZZ-6571-E	Seal, Exhaust – 0.015 O/S	-
10	74533	E7ZZ-6571-F	Seal, Exhaust – 0.030 O/S	-
11	74535	E8TZ-6582-D	Cover	-
12	73995	F1ZZ-6584-A	Gasket – Rocker Arm Cover	1
13	74550	N800030-S53B	Screw and Washer – M6X16	8
14	60836	FOAZ-6766-A	Cap	1
15	74523	E6JL-6057-AA	Seat	-

Fig. 11 – Piston, Connecting Rod Group

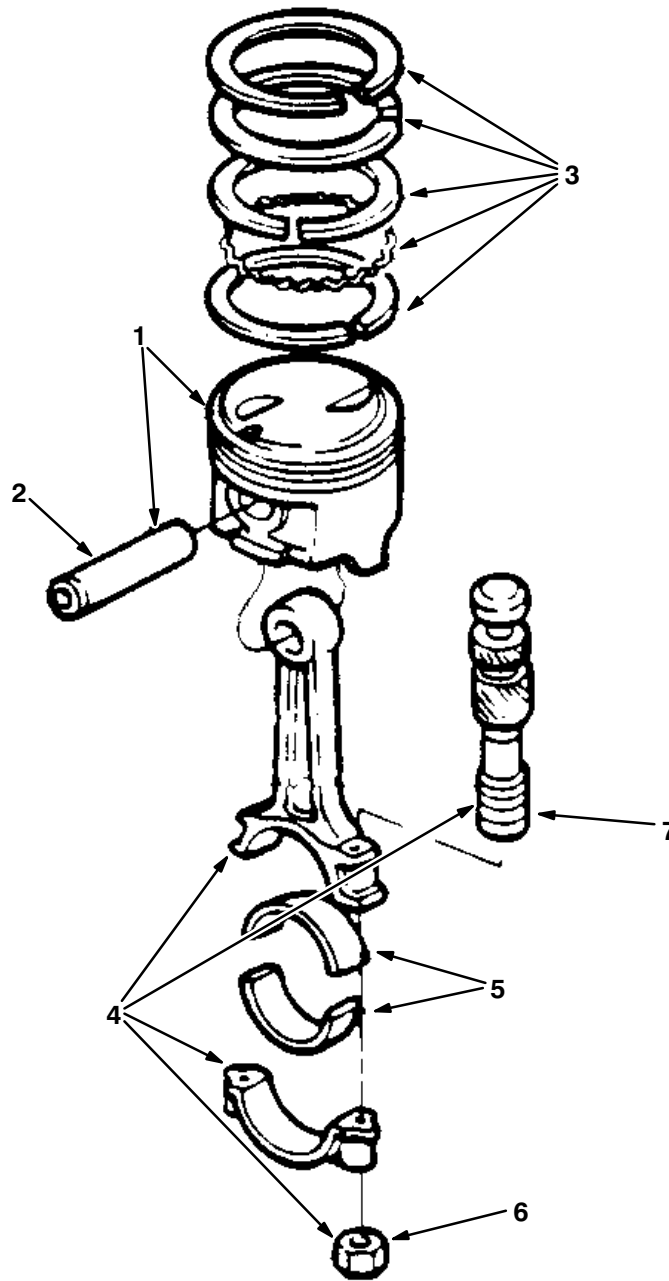

Fig. 11 – Piston, Connecting Rod Group

	Ref.	Tennant Part No.	Ford Part Number	Description	Qty.
▽	1	60809	D4FZ-6108-A	Piston Assembly Standard – Red	4
▽	1	73928	D4FZ-6108-B	Piston Assembly Standard – Blue	–
▽	1	73929	D4FZ-6108-CB	Piston Assembly 0.003 O/S	–
▽	1	73930	D4FZ-6108-DB	Piston Assembly 0.020 O/S	–
▽	1	73931	D4FZ-6108-EB	Piston Assembly 0.030 O/S	–
▽	1	73932	D4FZ-6108-FB	Piston Assembly 0.040 O/S	–
	2	73997	E3TZ-6135-A	Pin	4
	3	60810	D4FZ-6148-A	Ring Set Standard and .003 O/S	2
	3	73933	D4FZ-6148-B	Ring Set 0.020 O/S	–
	3	73934	D4FZ-6148-C	Ring Set 0.030 O/S	–
	3	73935	D4FZ-6148-D	Ring Set 0.040 O/S	–
▽	4	73976	E2ZZ-6200-A	Connecting Rod Assembly	4
	5	60812	D7FZ-6211-A	Bearing, Connecting Rod Standard, Red	8
	5	73977	D7FZ-6211-B	Bearing, Connecting Rod Standard, Blue	–
	5	73978	D7FZ-6211-C	Bearing, Connecting Rod 0.002 U/S	–
	5	73979	D7FZ-6211-D	Bearing, Connecting Rod 0.010 U/S	–
	5	73980	D7FZ-6211-E	Bearing, Connecting Rod 0.020 U/S	–
	5	73981	D7FZ-6211-F	Bearing, Connecting Rod 0.030 U/S	–
	5	73982	D7FZ-6211-G	Bearing, Connecting Rod 0.040 U/S	–
	6	60813	D4FZ-6212-A	Nut – M9	8
	7	60814	D4FZ-6214-A	Bolt – M9x55	8

Fig. 12 – Starter Breakdown

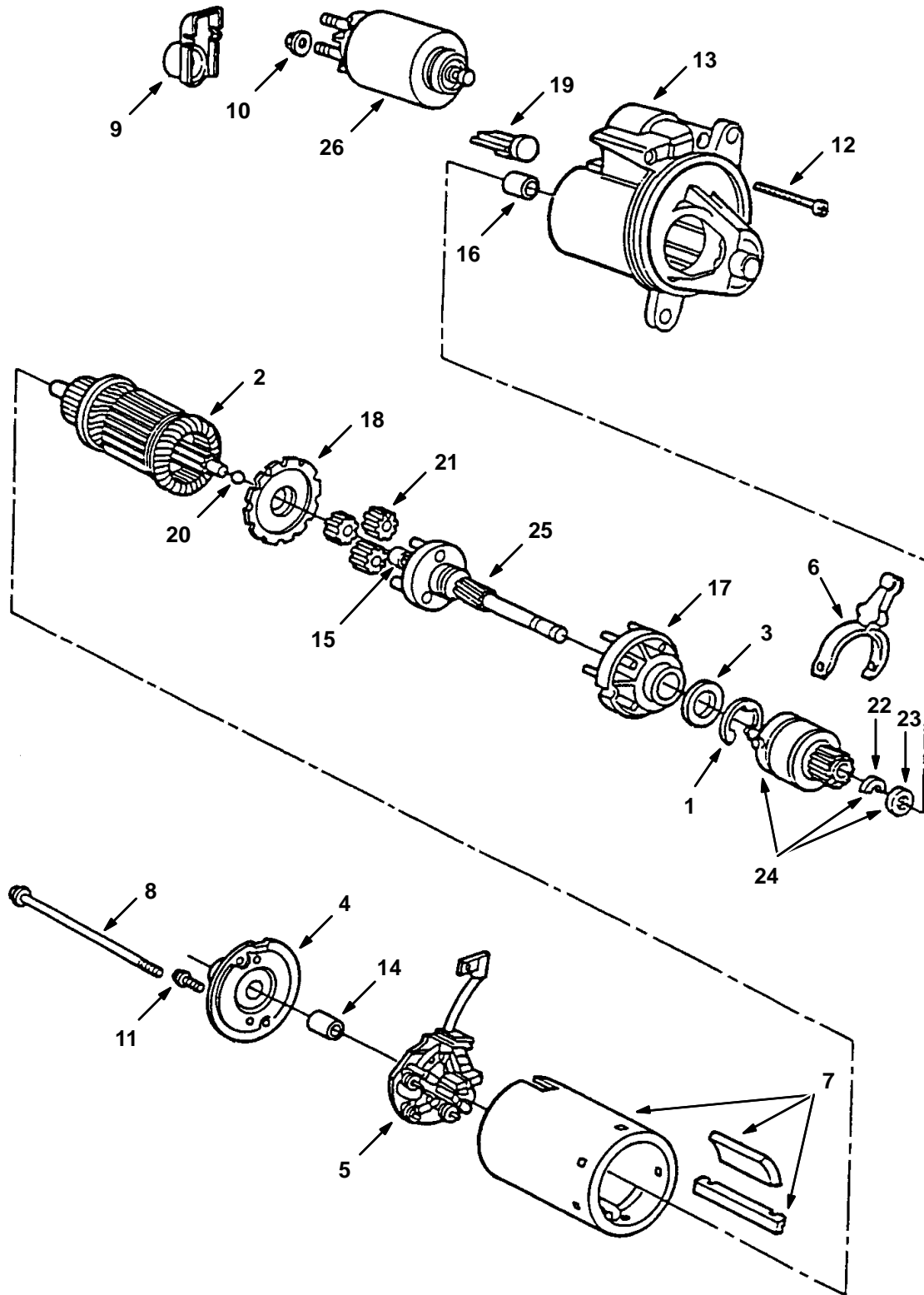
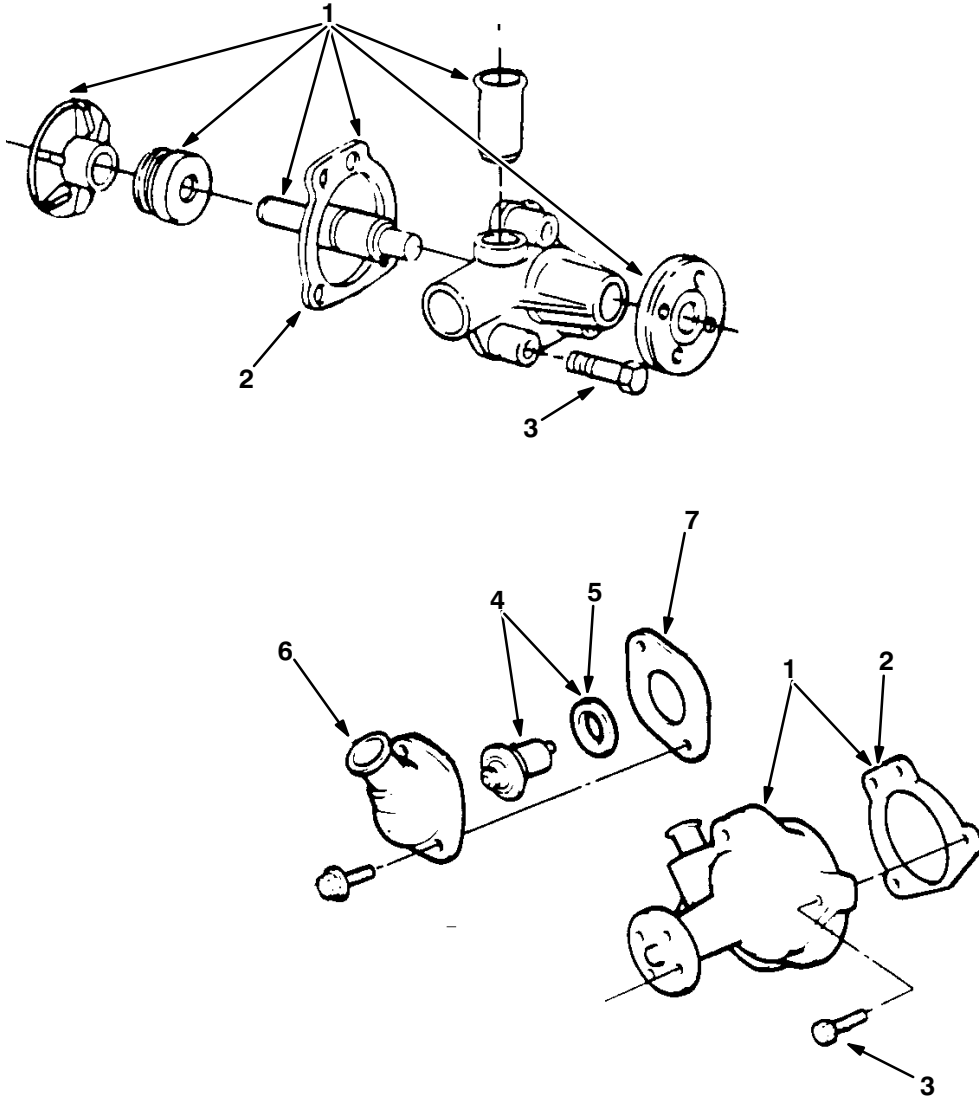

Fig. 12 – Starter Breakdown

Ref.	Tennant Part No.	Ford Part Number	Description	Qty.
▽	60938	F1TZ-11002-A	Motor, Starting, Perm Mag, 12V	1
1	79640	97476-S2	Retaining Ring	1
2	84999	E9OZ-11005-A	Armature	1
3	79956	E9OZ-11036-A	Washer	1
4	79628	E9OZ-11049-A	Plate & Brg	1
5	79629	E9OZ-11061-C	Brush Holder	1
6	79630	E9OZ-11067-A	Lever	1
7	79631	E9OZ-11075-A	Frame&Mag.As	1
8	79632	E9SZ-11091-A	Bolt-Thru	2
9	79970	E9OZ-11N087-A	Term.Cover	1
▽	79633	E9OZ-11A091-A	Kit-Attaching	1
10	79957	N805403-S100	Nut&Washer,M8	1
11	79958	N805406-S36B	Screw,M5X10.4M	2
12	79959	N805405-S36B	Screw,M6X35.3M	2
13	79634	F1TZ-11130-A	Hsg W/Brg	1
14	79635	MC-209-A	Bearing	1
15	79960	E9OZ-11135-A	Planet Bearing	3
16	79961	F2TZ-11135-A	Bearing	1
17	79962	E9OZ-11A165-A	Statnry Gear	1
18	79963	E9OZ-11A167-A	Retnr.Gear	1
19	79964	E9OZ-11A171-A	Seal	1
20	79965	E9OZ-11A172-A	Arm.Thr.Ball	1
21	79966	E9OZ-11K190-A	Gear Assy	3
22	79636	C2DZ-11222-A	Ring-Drv.Stop	1
23	79967	D6AZ-11223-A	Retainer	1
24	79638	E9OZ-11350-A	Drive Assy	1
25	79969	FOTZ-11355-A	Shft Asy,Output	1
26	79639	F3VY-11390-B	Solenoid	1

Fig. 13 – Water Pump, Thermostat Group



06840/06780

Ref.	Tennant Part No.	Ford Part Number	Description	Qty.
∇ 1	60838	E6ZZ-8501-A	Pump – Includes Gasket – 5/8 Pilot	1
2	74539	E8ZZ-8507-A	Gasket – Water Pump	1
3	74549	N605663-S100	Bolt – M8 x 50	3
4	60839	E2JL-8A570-AA	Thermostat And Seal Assembly – 170°F	1
5	74557	E5FZ-8590-A	Seal – Thermostat	1
6	73996	RH14	Water Outlet	1
7	74538	E8ZZ-8255-A	Gasket – Water Outlet	1

Fig. 14 – Ignitions Group

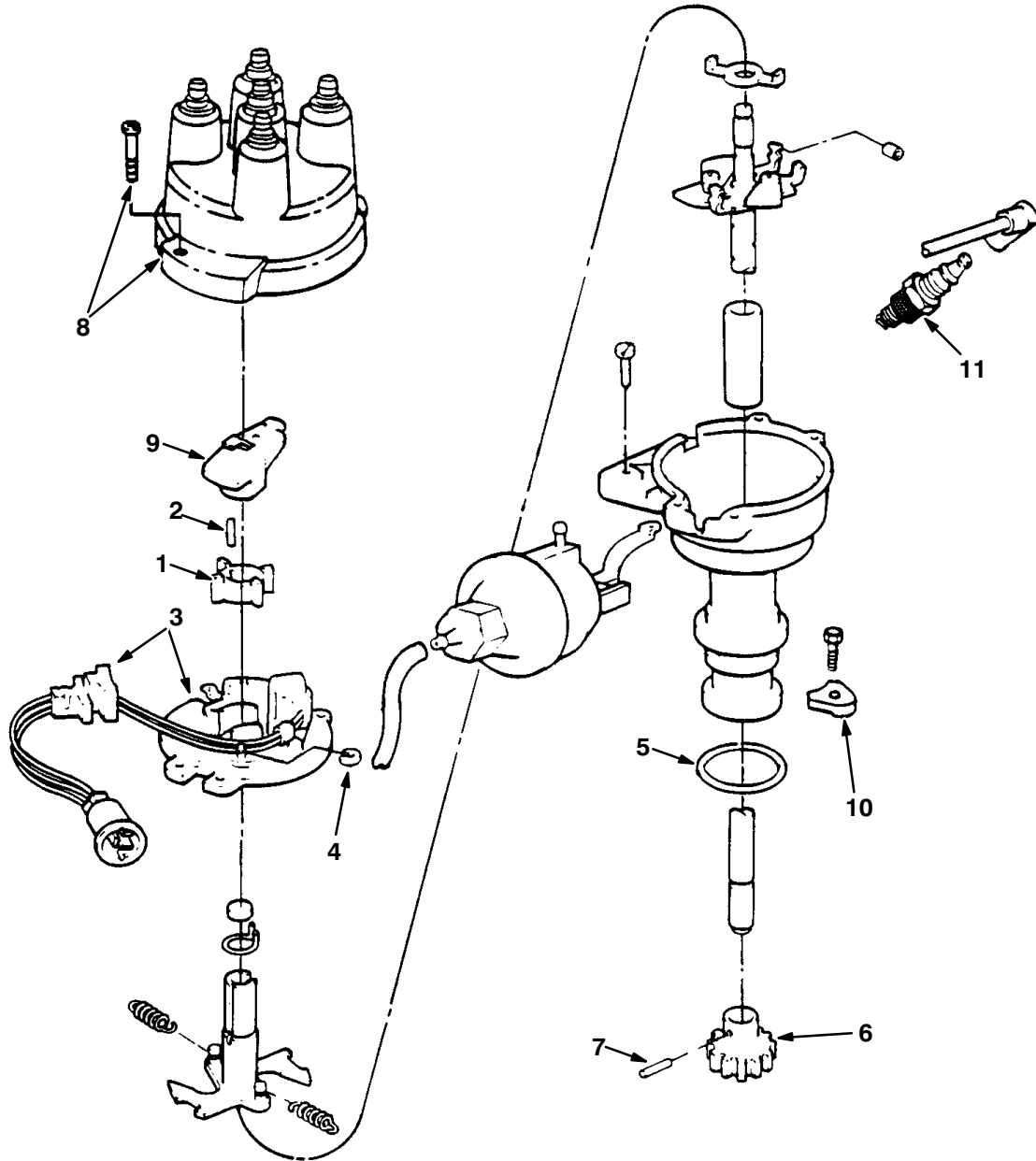

06841/06782

Ref.	Tennant Part No.	Ford Part Number	Description	Qty.
∇	60845	D9JE-12127-BA	Distributor – Less Cap And Rotor	1
1	35705	D7FZ-12A099-A	Armature	1
2	35716	305015-S	Pin – Armature	1
3	35719	D5TZ-12A112-B	Stator Assembly	1
4	73912	351826-S	Washer – “C” Type	1
5	73923	DZ-4	O-Ring Seal – Distributor To Block	1
6	73972	DZ-472	Gear – Driven	1
7	73916	67555-S	Pin – 1/8 x 3/4	1
8	60844	E5BZ-12106-A	Cap – Distributor	1
9	60875	E6TZ-12200-E	Rotor – Distributor	1
10	73993	DZ-468-A	Clamp – Distributor To Block	1
11	60846	AWSF-52-C	Spark Plug	4

SECTION 6**CONTENTS**

	PAGE
Fig. 1 – Engine Block Group	6-2
Fig. 2 – Gaskets Group	6-4
Fig. 3 – Cylinder Head Group	6-6
Fig. 4 – Cylinder Front Cover Group	6-7
Fig. 5 – Starter Breakdown	6-8
Fig. 6 – Oil Pan Group	6-10
Fig. 7 – Crankshaft Group	6-12
Fig. 8 – Manifolds Group	6-14
Fig. 9 – Flywheel Group	6-15
Fig. 10 – Camshaft And Sprocket Group	6-16
Fig. 11 – Valve And Rocker Arm Cover Group	6-18
Fig. 12 – Piston And Connecting Rod Group	6-20
Fig. 13 – Water Pump, Thermostat and Fan Group	6-21
Fig. 14 – Ignition Group	6-22

Fig. 1 – Engine Block Group

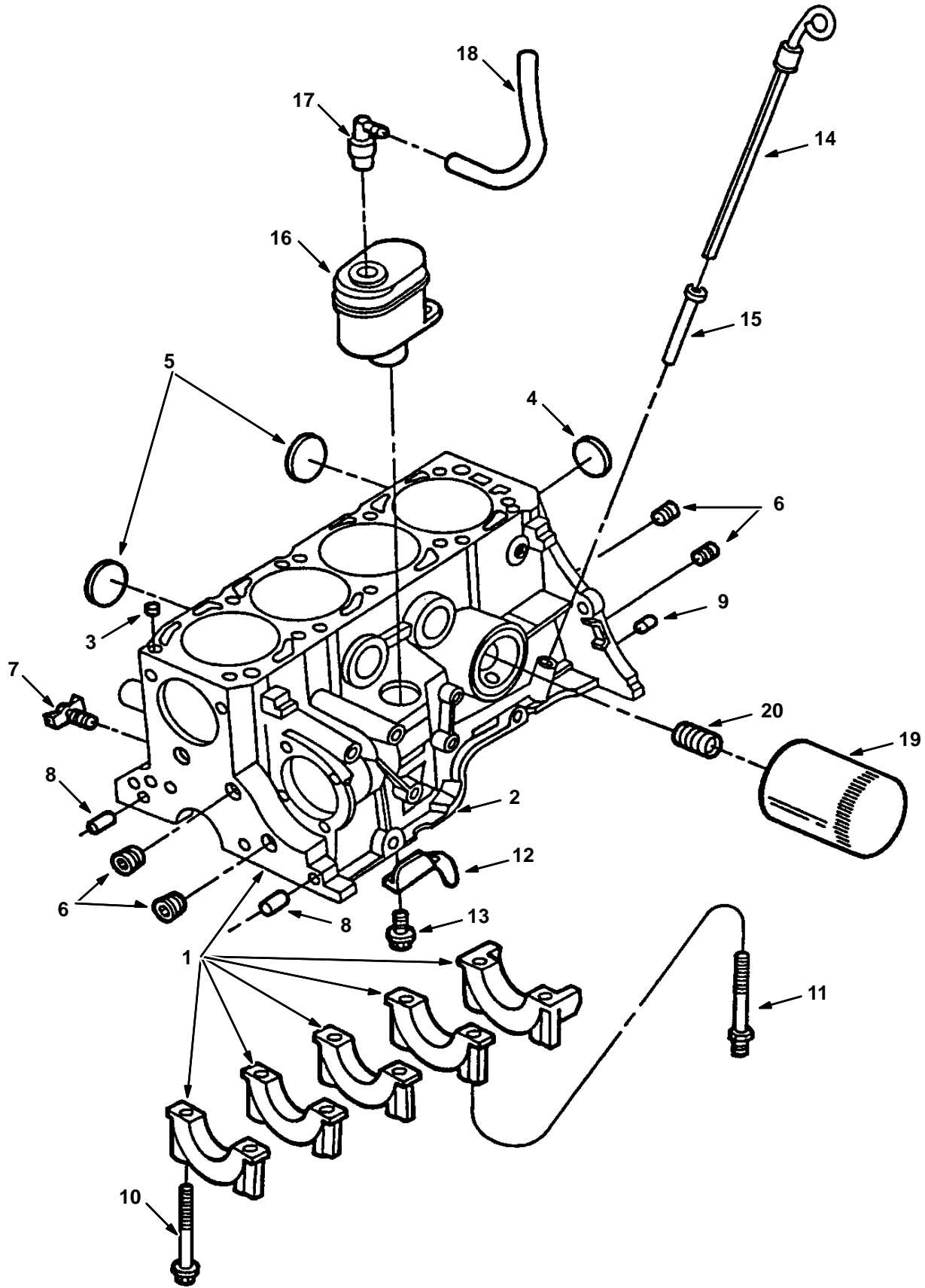

Fig. 1 – Engine Block Group

Ref.	Tennant Part No.	Ford Part Number	Description	Qty.
1	84875	F57Z-6009-B	Cyl Block Assy (Short Block Assy)	1
3	73958	D4FZ-6A008-A	Dowel	2
4	73921	C5AZ-6026-J	Plug-Std 2.078	1
4	73920	C5AZ-6026-H	Plug .06 O/S	-
5	84877	E6DZ-6026-B	Plug, 1.50 Cup	4
6	73917	87838-S101	Plug 3/8 Npt	5
6	36268	F1ZZ-6026-B	Plug 1/4 Npt	2
7	54911-32	8A-8115-A	Draincock,End.Block	1
8	84878	N807419-S	Dowel,Frnt Cover	2
9	73975	D7BZ-6397-A	Dowel	2
10	73950	D4FZ-6345-A	Bolt M12	9
11	74516	E5ZZ-6345-A	Stud M12	1
12	84879	F57Z-6A630-A	Baffle	1
13	84880	N605890-S2	Bolt, M6X16.5mm	2
14	84881	F5JL-6750-AA	Indicator,Oil	1
15	10724	E4JL-6754-AA	Short Tube	1
16	84882	F5TZ-6A785-A	Separator	1
17	84883	E97E-6A666-A2A	Pcv Vlv Asy	1
18	84884	F5JL-6853-A	Hose	1
19	37301	D9AZ-6731-A	Filter, Oil	1
20	84962	E8ZZ-6890-A	Insert-Oilfilt	1

Fig. 2 – Gaskets Group

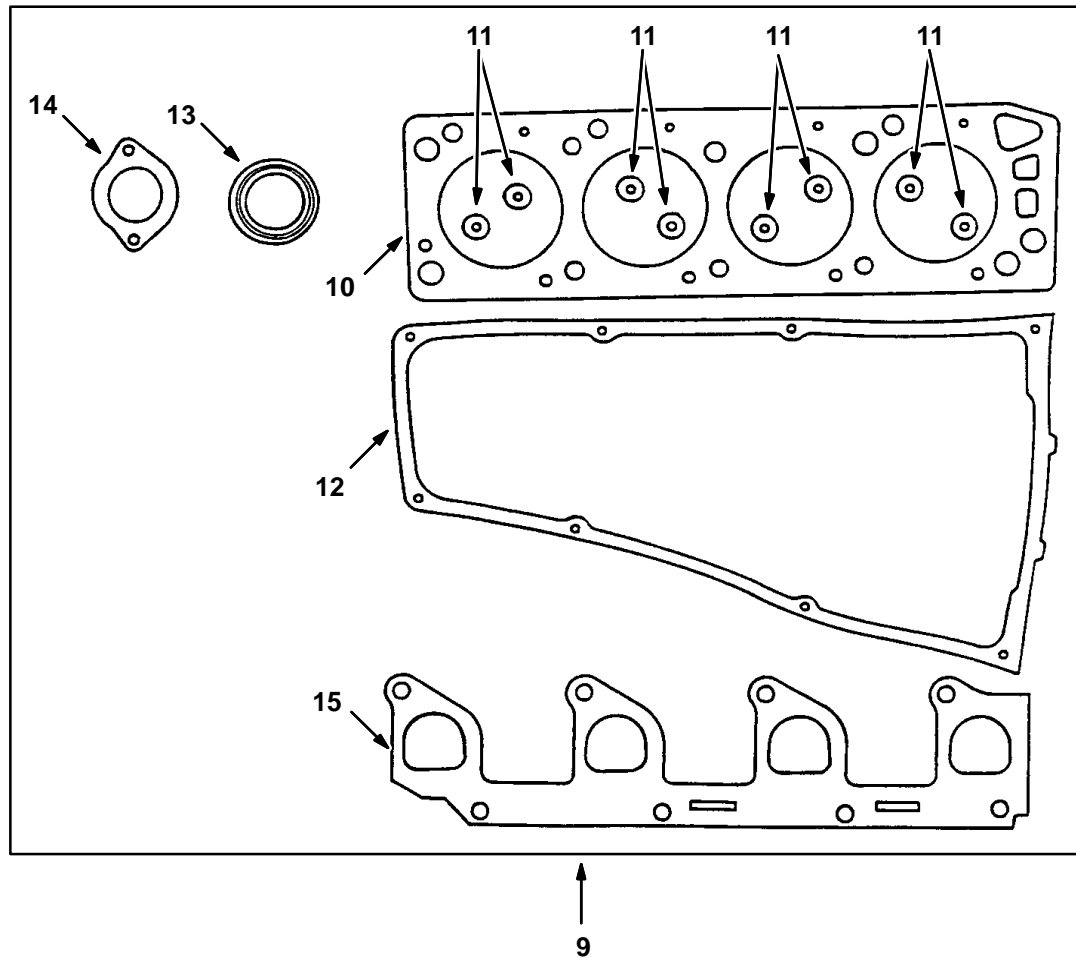
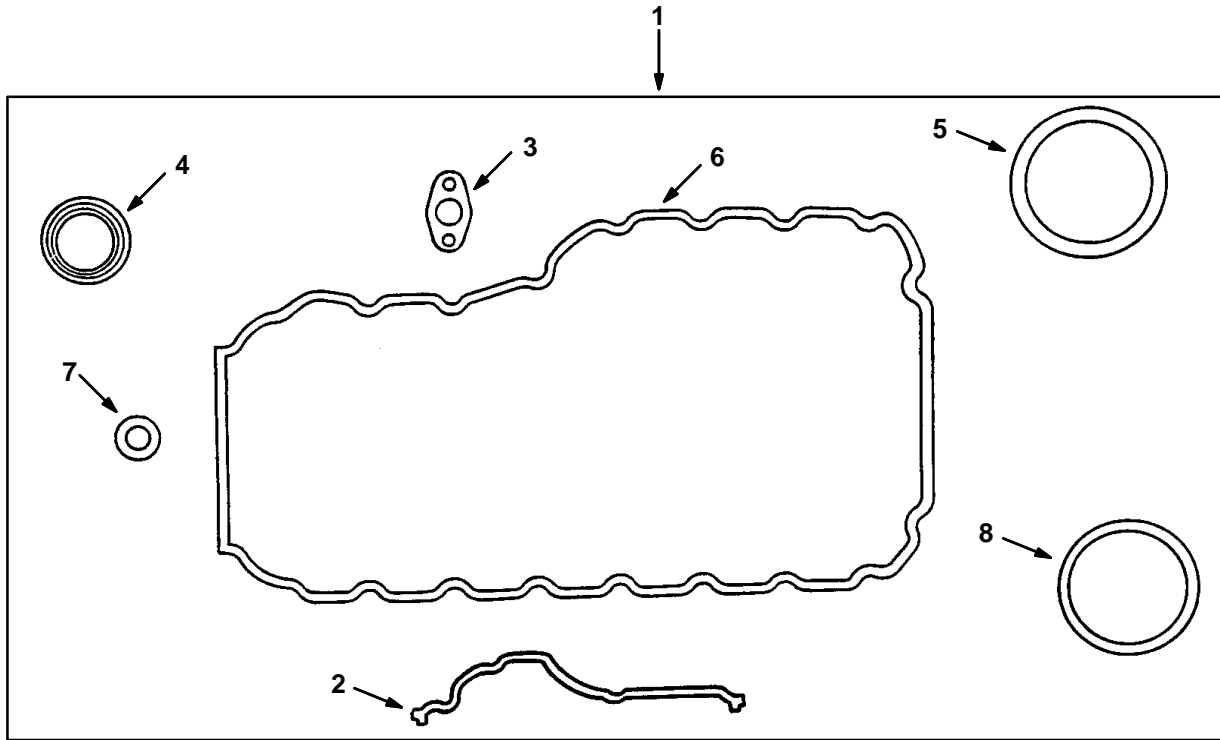

Fig. 2 – Gaskets Group

	Ref.	Tennant Part No.	Ford Part Number	Description	Qty.
∇	1	84885	F57Z-6E078-A	Gskt Kit,Lower	1
	2	84886	F57Z-6020-A	Gskt,Frnt Cvr	1
	3	84887	F57Z-6626-A	Gskt,Pmp/Putube	1
	4	60833	E8ZZ-6700-A	Oil Seal, Front	1
	5	84888	F4AZ-6701-A	Seal, Rear	1
	6	84889	F57Z-6710-A	Gasket,Oil Pan	1
	7	37157	F3DZ-6734-A	Gasket Oil	1
	8	84983	F57Z-8507-A	Gskt,Water Pump	1
∇	9	84891	F57Z-6079-A	Gskt Kit,Upper	1
	10	60806	F3ZZ-6051-C	Gasket, Head	1
	11	84892	F57Z-6571-A	Seal,Valve Stem	8
	12	84893	F57Z-6584-A	Gskt,Rockr Cvr	1
	13	60833	E8ZZ-6700-A	Oil Seal, Front	1
	14	74538	E8ZZ-8255-A	Gskt-Waterout	1
	15	84894	F57Z-9439-B	Gskt,In.Manfld	1

Fig. 3 – Cylinder Head Group

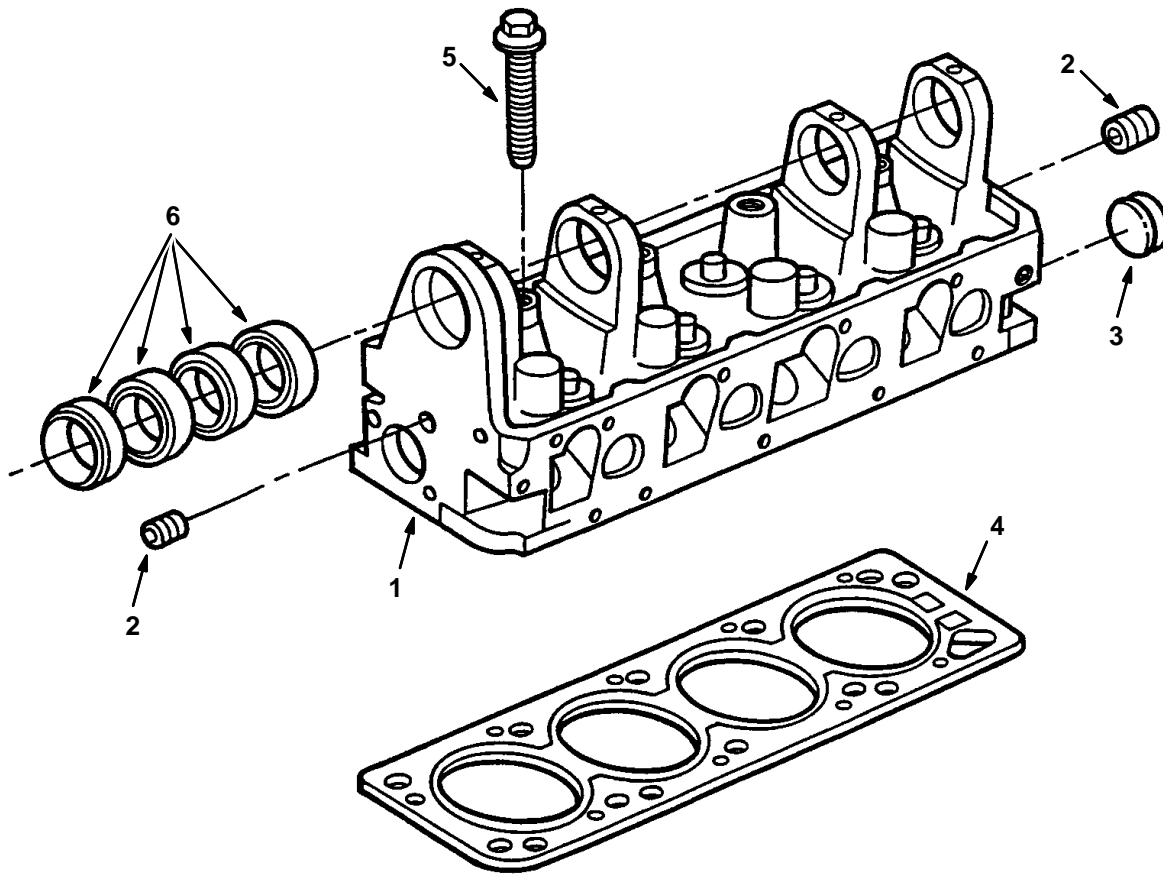
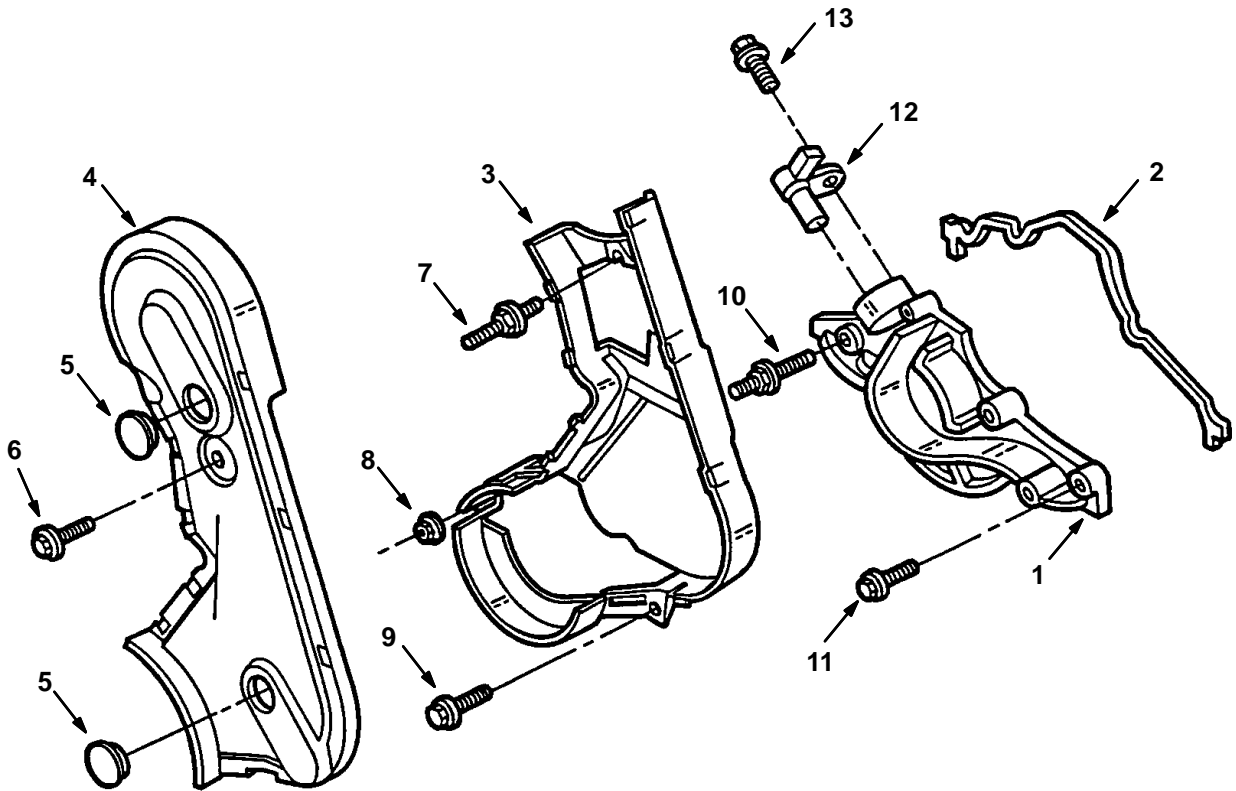

Fig. 3 – Cylinder Head Group

10531/10445

Ref.	Tennant Part No.	Ford Part Number	Description	Qty.
1	84907	F57Z-6049-A	Head-W/O Valves	1
1	84908	F57Z-6049-B	Head-W/Vlvs&Cam	1
2	36268	F1ZZ-6026-B	Plug 1/4 Npt	2
3	84910	E6DZ-6026-B	Plug,1.50 Cup	1
4	60806	F3ZZ-6051-C	Gasket, Head	1
5	73927	F3ZZ-6065-A	Bolt M12	10
6	60817	D4FZ-6261-C	Bearing Cam,	4
6	73936	D4FZ-6261-B	Bearing, .016 Camshaft	-

Fig. 4 – Cylinder Front Cover Group



10532/10446

Ref.	Tennant Part No.	Ford Part Number	Description	Qty.
1	84895	F57Z-6019-B	Lower Cover	1
2	84896	F57Z-6020-A	Gskt,Front Cvr	1
3	84897	F57Z-6019-C	Inner Cover	1
4	84898	F57Z-6019-A	Outer Cover	1
5	74536	E8ZZ-6026-A	Plug	2
6	84899	N808534-S2	Bolt, M8 X 17 Schd	1
7	84900	N808049-S102	Stud,M8X51.0mm	1
8	84901	N621906-S2	Nut, M6	1
9	84902	N804958-S8	Scr&Wsh,M6X22.5	1
10	84903	N807288-S2	Stud,M6X61.8mm	1
11	84904	N807497-S2	Bolt,M6X37.5mm	3
12	84905	F57Z-6C315-A	Sensor,Crnksft	1
13	84906	N605892-S2	Screw,M6X22.5mm	1

Fig. 5 – Starter Breakdown

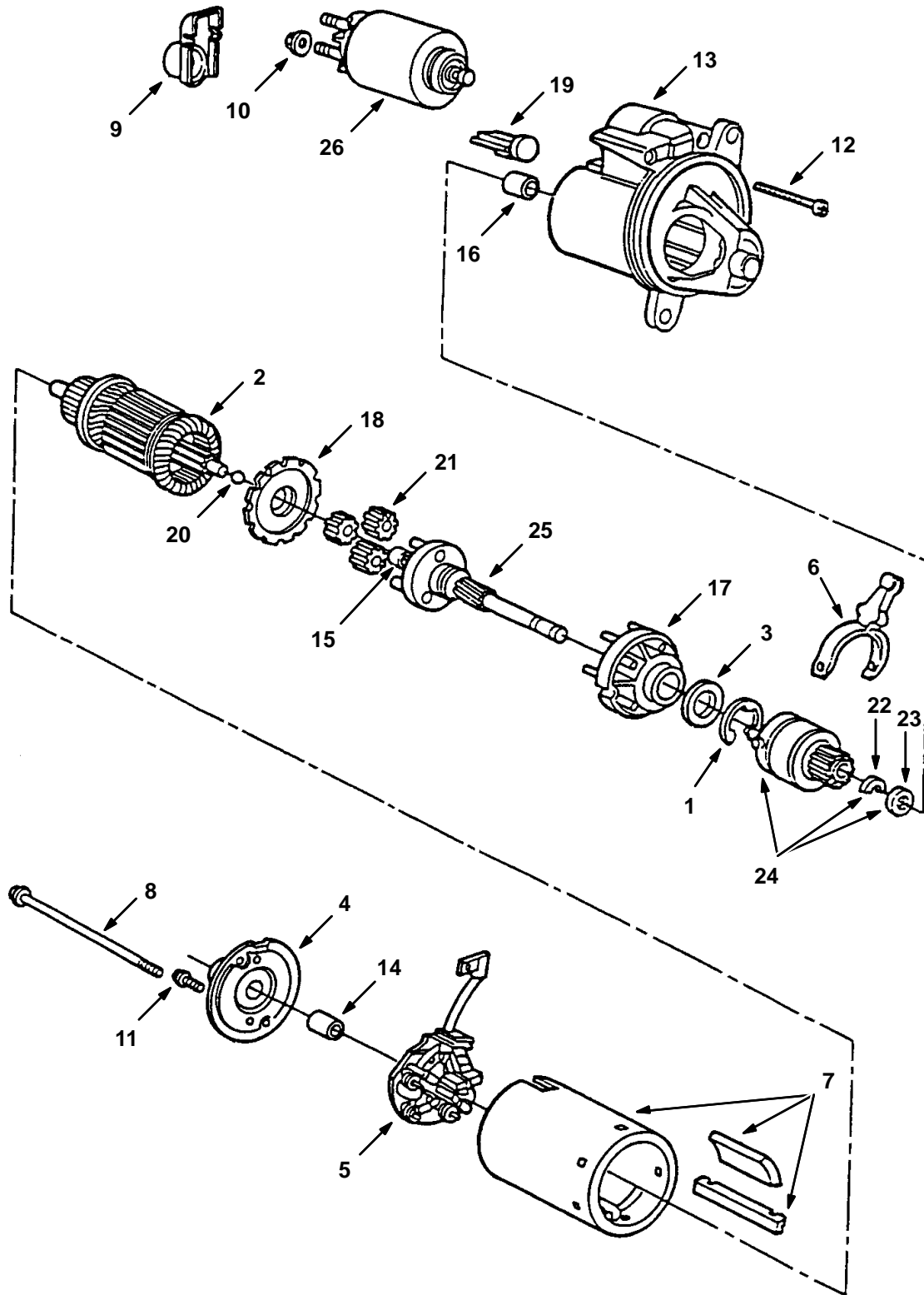

Fig. 5 – Starter Breakdown

Ref.	Tennant Part No.	Ford Part Number	Description	Qty.
▽	60938	F1TZ-11002-A	Motor, Starting, Perm Mag, 12V	1
1	79640	97476-S2	Retaining Ring	1
2	84999	E9OZ-11005-A	Armature	1
3	79956	E9OZ-11036-A	Washer	1
4	79628	E9OZ-11049-A	Plate & Brg	1
5	79629	E9OZ-11061-C	Brush Holder	1
6	79630	E9OZ-11067-A	Lever	1
7	79631	E9OZ-11075-A	Frame&Mag.As	1
8	79632	E9SZ-11091-A	Bolt-Thru	2
9	79970	E9OZ-11N087-A	Term.Cover	1
▽	79633	E9OZ-11A091-A	Kit-Attaching	1
10	79957	N805403-S100	Nut&Washer,M8	1
11	79958	N805406-S36B	Screw,M5X10.4M	2
12	79959	N805405-S36B	Screw,M6X35.3M	2
13	79634	F1TZ-11130-A	Hsg W/Brg	1
14	79635	MC-209-A	Bearing	1
15	79960	E9OZ-11135-A	Planet Bearing	3
16	79961	F2TZ-11135-A	Bearing	1
17	79962	E9OZ-11A165-A	Statnry Gear	1
18	79963	E9OZ-11A167-A	Retnr.Gear	1
19	79964	E9OZ-11A171-A	Seal	1
20	79965	E9OZ-11A172-A	Arm.Thr.Ball	1
21	79966	E9OZ-11K190-A	Gear Assy	3
22	79636	C2DZ-11222-A	Ring-Drv.Stop	1
23	79967	D6AZ-11223-A	Retainer	1
24	79638	E9OZ-11350-A	Drive Assy	1
25	79969	FOTZ-11355-A	Shft Asy,Output	1
26	79639	F3VY-11390-B	Solenoid	1

Fig. 6 – Oil Pan Group

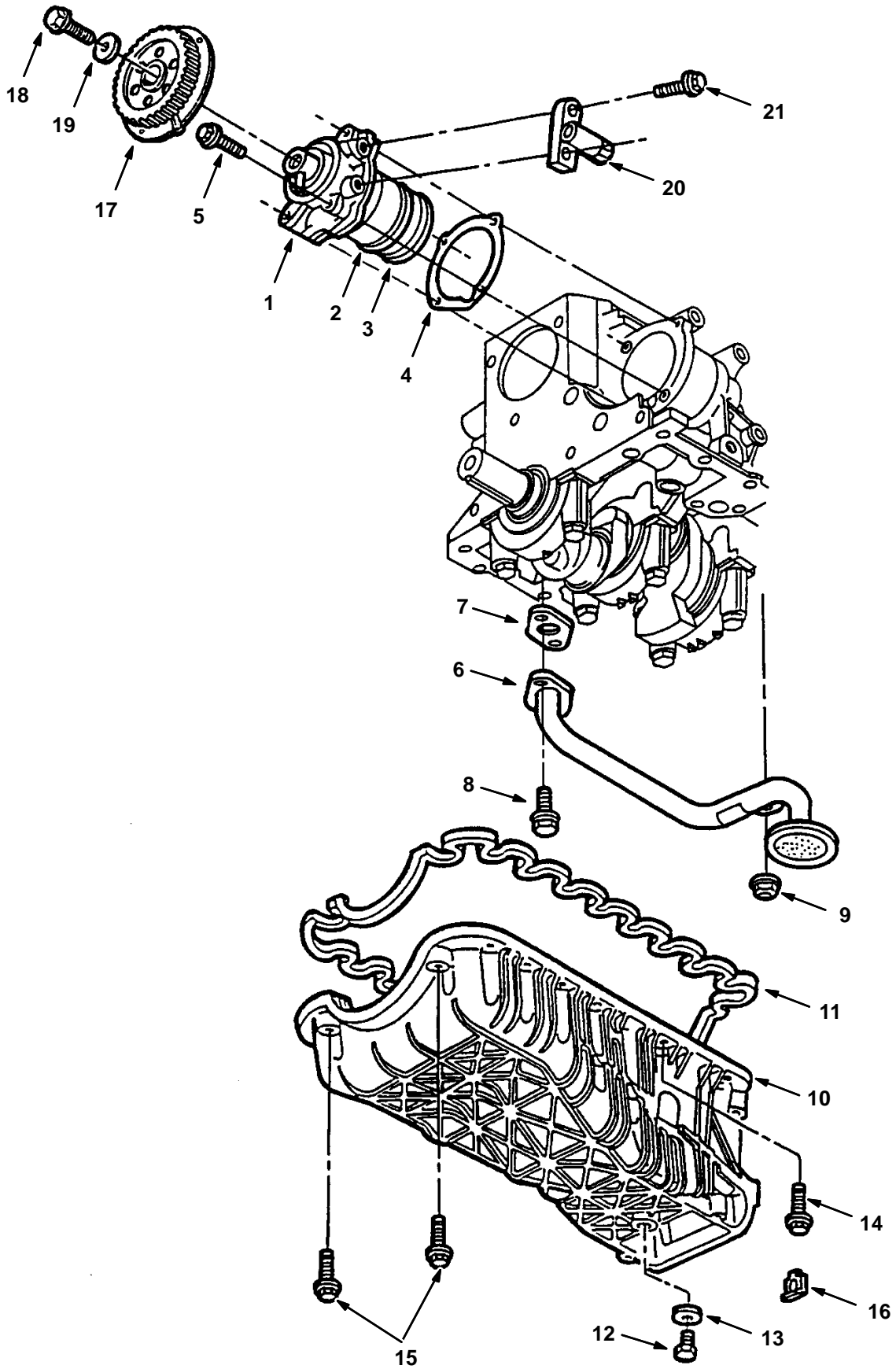

Fig. 6 – Oil Pan Group

Ref.	Tennant Part No.	Ford Part Number	Description	Qty.
1	84963	F57Z-6600-A	Oil Pump	1
2	84964	87071-S100	O-Ring,2.375	1
3	84965	87072-S100	O-Ring-2.250	1
4	84966	F57Z-6659-A	Gskt,Oilpmp/Blk	1
5	84967	N606523-S2	Bolt,M6X47.5mm	4
6	84968	F57Z-6622-A	Oil Pickup Tube	1
7	84969	F5TZ-6626-A	Gskt,Pu Tube	1
8	84970	N605786-S2	Bolt,M8X20.0mm	2
9	84971	N620482-S2	Nut,M10	1
10	84972	F57Z-6675-A	Oil Pan Assy	1
11	84889	F57Z-6710-A	Gasket,Oil Pan	1
12	37127	F3DZ-6730-A	Oil Plug	1
13	37157	F3DZ-6734-A	Gasket Oil	1
14	84973	N806378-S141	Bolt,M6X27.5mm	16
15	84974	N806379-S141	Bolt,M6X52.5mm	2
16	84975	E69Z-6C629-A	Oil Pan Spacer	-
16	84976	E69Z-6C629-B	Oil Pan Spacer	-
16	84977	E69Z-6C629-C	Oil Pan Spacer	-
17	84978	F57Z-6256-A	Oil Pmp Sprkt	1
18	84979	N600313-S2	Bolt,M10X40.0mm	1
19	74561	D4FZ-6278-B	Washer	1
20	84980	F57Z-6B288-A	Camsft.Sensor	1
21	84981	N605880-S309B	Bolt,M5X20.0M	2

Fig. 7 – Crankshaft Group

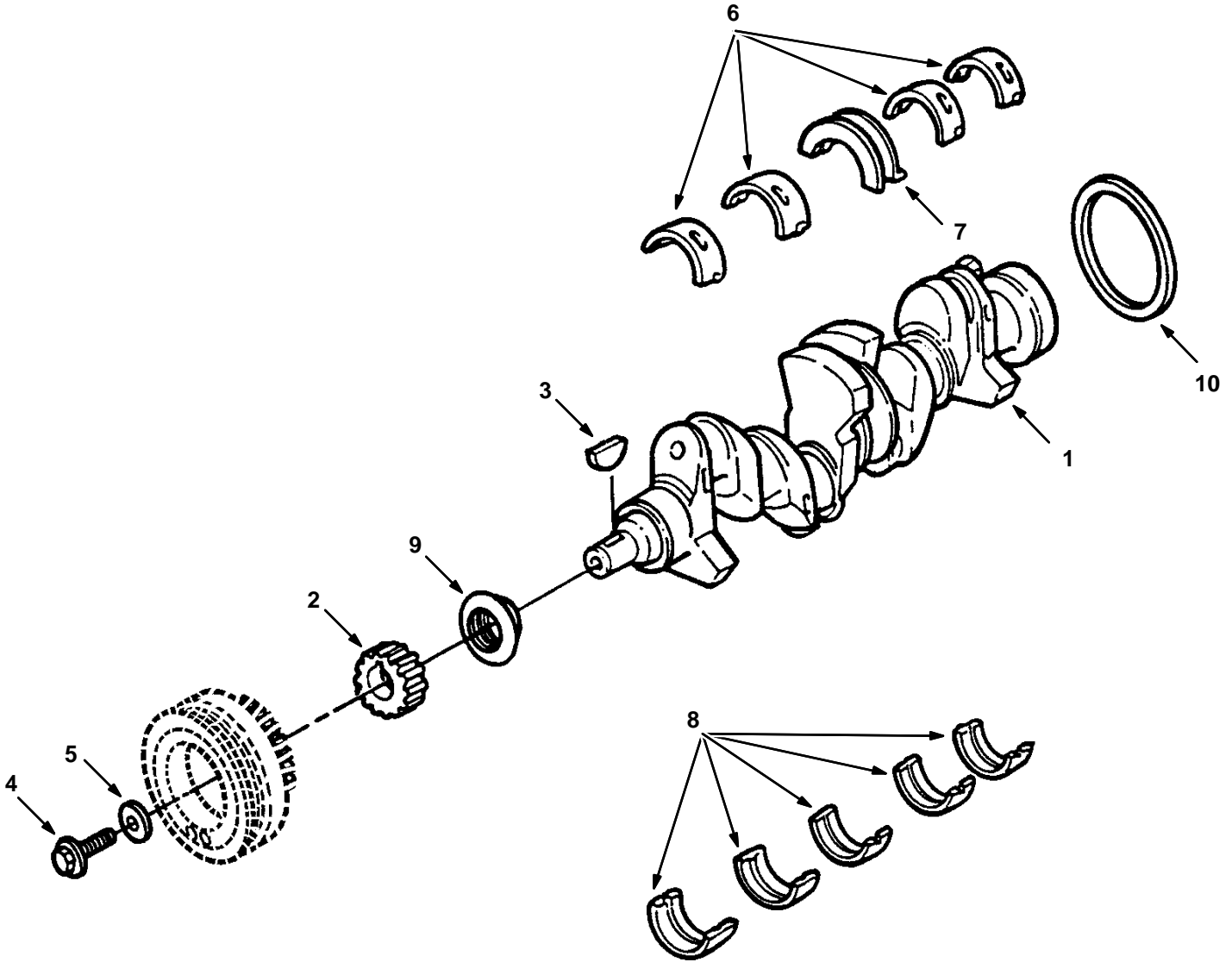
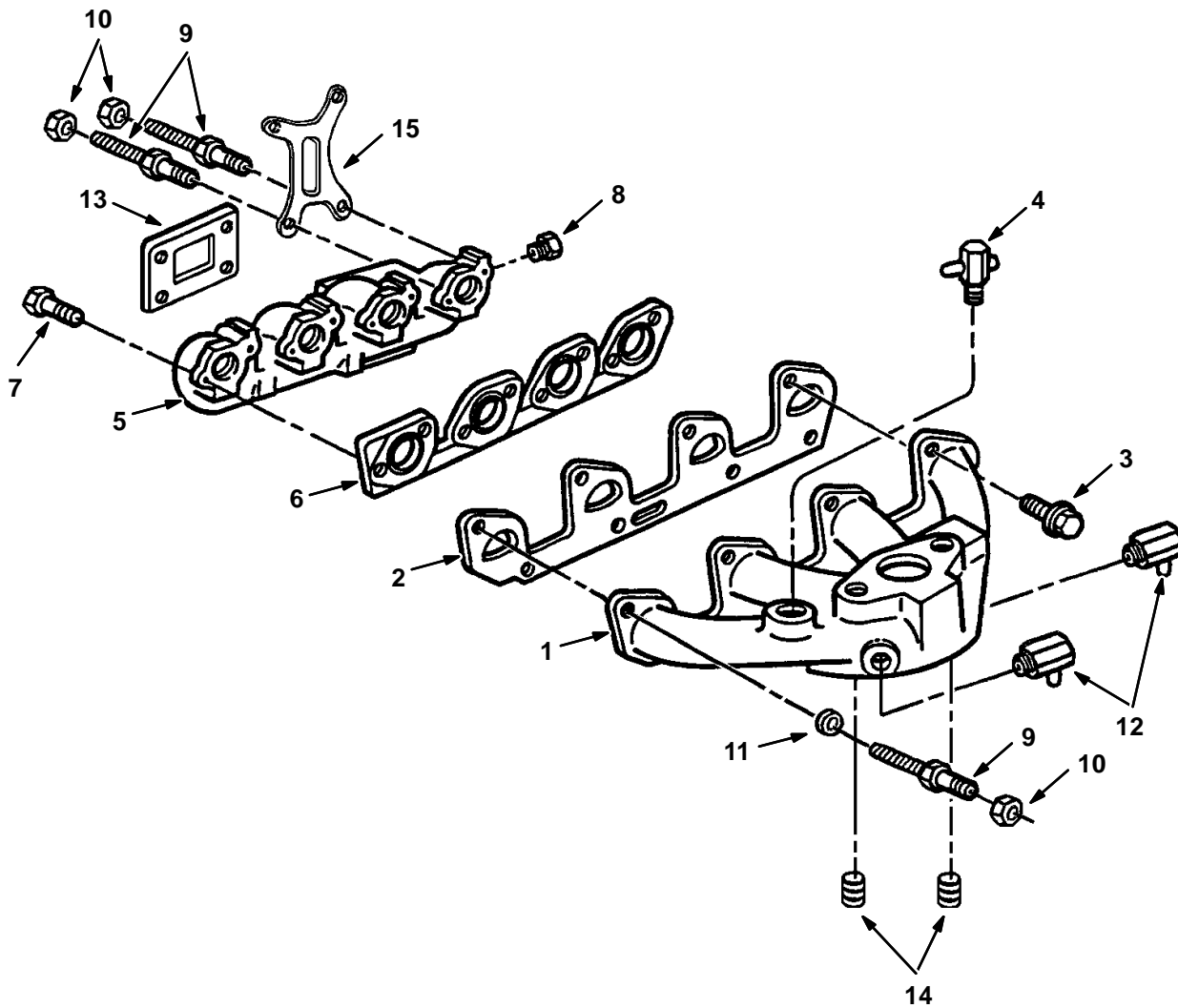

Fig. 7 – Crankshaft Group

Ref.	Tennant Part No.	Ford Part Number	Description	Qty.
1	84923	F57Z-6303-A	Crankshaft Asy	1
2	84924	F1ZZ-6306-A	Crnksft Sprckt	1
3	84925	F1ZZ-6B316-A	Crnkshaft Key	1
4	84926	F1ZZ-6A340-A	Bolt,M14X55.0M	1
5	84927	D8BZ-6378-A	Wash M15 1.53Od	1
6	84928	F57Z-6333-A	Main Brg,Stdred	4
6	84929	F57Z-6333-B	Main Brg,Stdblu	-
6	84930	F57Z-6333-C	Main Brg,.002 Upper	-
6	84931	F57Z-6333-D	Main Brg,.010 Upper	-
6	84932	F57Z-6333-E	Main Brg,.020 Upper	-
6	84933	F57Z-6333-F	Main Brg,.030 Upper	-
7	84934	F57Z-6337-A	Thr.Brg,Stdred	1
7	84937	F57Z-6337-B	Thr.Brg,Stdblu	-
7	84935	F57Z-6337-C	Thr.Brg,.002 Upper	-
7	84938	F57Z-6337-D	Thr.Brg,.010 Upper	-
7	84939	F57Z-6337-E	Thr.Brg,.020 Upper	-
7	84940	F57Z-6337-F	Thr.Brg,.030 Upper	-
8	84941	F57Z-6333-H	Main Brg,Stdred	5
8	84942	F57Z-6333-J	Main Brg,Stdblu	-
8	84943	F57Z-6333-K	Main Brg,.002 Lower	-
8	84944	F57Z-6333-L	Main Brg,.010 Lower	-
8	84945	F57Z-6333-M	Main Brg,.020 Lower	-
8	84946	F57Z-6333-N	Main Brg,.030 Lower	-
9	60833	E8ZZ-6700-A	Oil Seal, Front	1
10	84947	F4AZ-6701-A	Crnksft Seal-Rear	1

Fig. 8 – Manifolds Group



10543/10529

Ref.	Tennant Part No.	Ford Part Number	Description	Qty.
1	84990	F5JL-9424-AA	Int.Manifold	1
2	84991	F57Z-9439-B	Gskt,Int.Mnfl	1
3	84992	N605787-S52	Bolt,M8X25.0mm	7
4	74527	E7TZ-9A474-C	Vac.Fitting	1
5	74509	E3ZZ-9430-A	Exh.Manifold	1
6	84995	F37Z-9448-A	Gskt,Exh.Mnfl	1
7	84996	N802209-S100	Bolt,M10X55.0M	6
8	84997	87889-S	Plug, 1/2Npt	1
9	79972	N808163-S100	Stud	3
10	79973	N620481-S2	Nut M8-1.25	3
11	79974	F5JL-17N090-CA	Spacer	1
12	84985	E8DZ-18599-B	Elbow,90 deg	2
13	36048	E3ZZ-9450-A	Gasket, Exh. Flange	1
14	73917	87838-S101	Plug 3/8 NPT	2
15	79976	F57E-17K004-BB	Lifting Eye	1

Fig. 9 – Flywheel Group

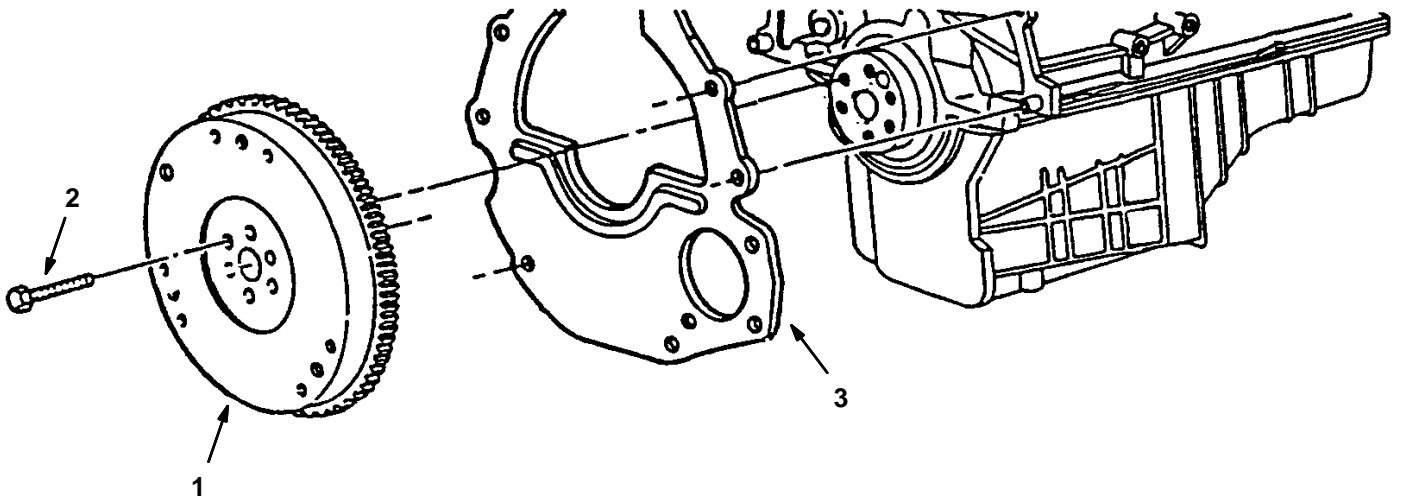

10541/10527

Ref.	Tennant Part No.	Ford Part Number	Description	Qty.
1	62424		Flywheel	1
2	84948	D9JI-6379-B	Bolt,M10X45.0mm	6
3	83669	E69Z-7007-A	Rear Plate	1

Fig. 10 – Camshaft And Sprocket Group

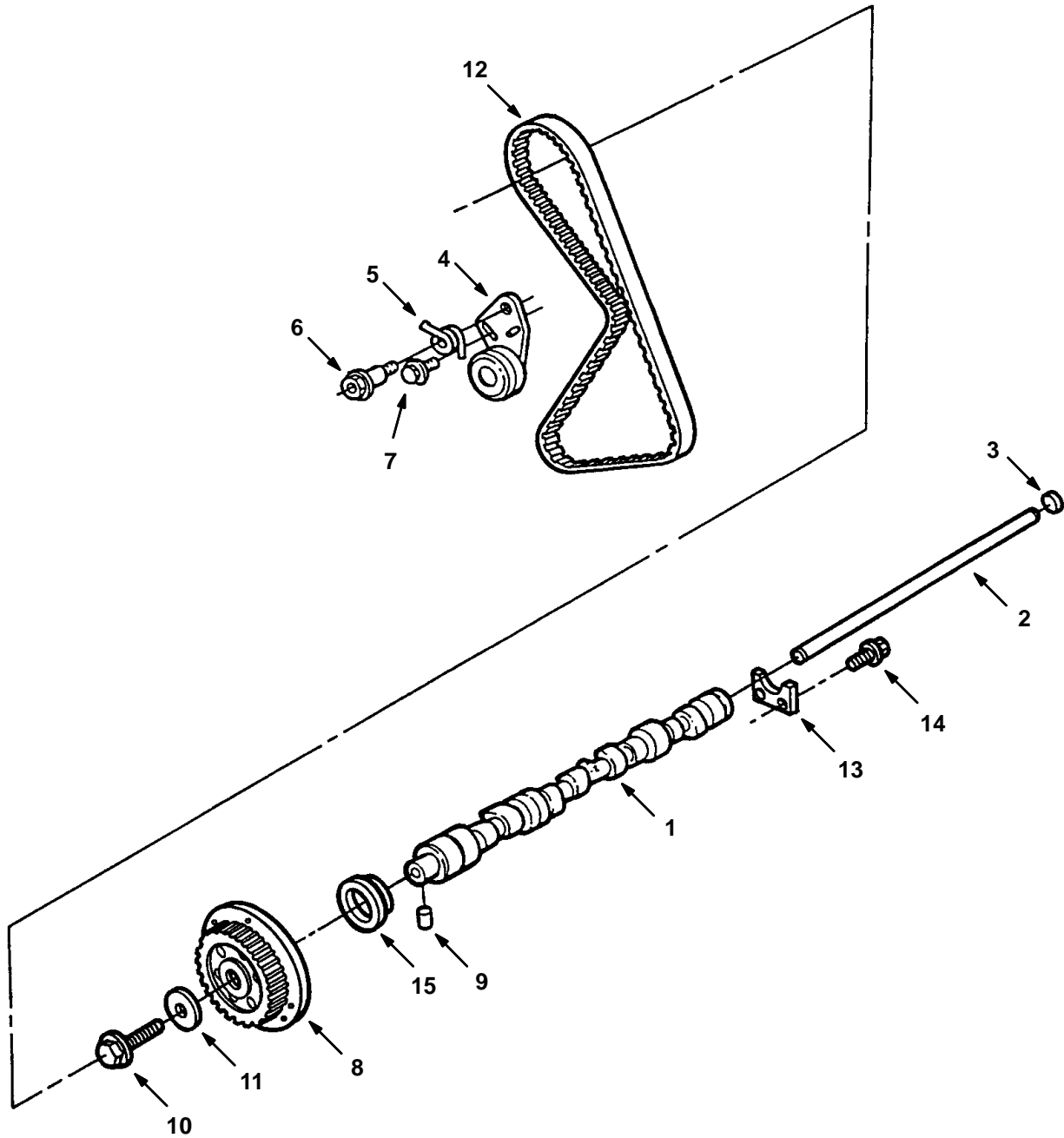

Fig. 10 – Camshaft And Sprocket Group

Ref.	Tennant Part No.	Ford Part Number	Description	Qty.
1	84915	F57Z-6250-B	Camshaft	1
2	84916	F57Z-6B273-A	Rod	1
3	84917	E7HZ-6026-E	Plug	1
4	73967	F57Z-6K254-A	Tens.Asy&Tbelt Tensioner, Arm	1
5	73970	D4FZ-6L273-A	Spring, Tension	1
6	84919	FOTZ-6K282-B	Bolt, Tens. Sprn	1
7	74552	N800112-S2	Bolt	1
8	84920	F57Z-6256-A	Camshft Sprckt	1
9	84921	391202-S	Pin, 1/4X.32	1
10	74545	N600414-S100	Bolt M12X45	1
11	73937	D4FZ-6278-A	Washer	1
12	84936	F57Z-6268-A	Timing Belt	1
13	73954	D4Fz-6613-A	Plate	1
14	74548	N604465-S	Scr&Wash M6	2
15	60833	E8ZZ-6700-A	Oil Seal, Front	1

Fig. 11 – Valve And Rocker Arm Cover Group

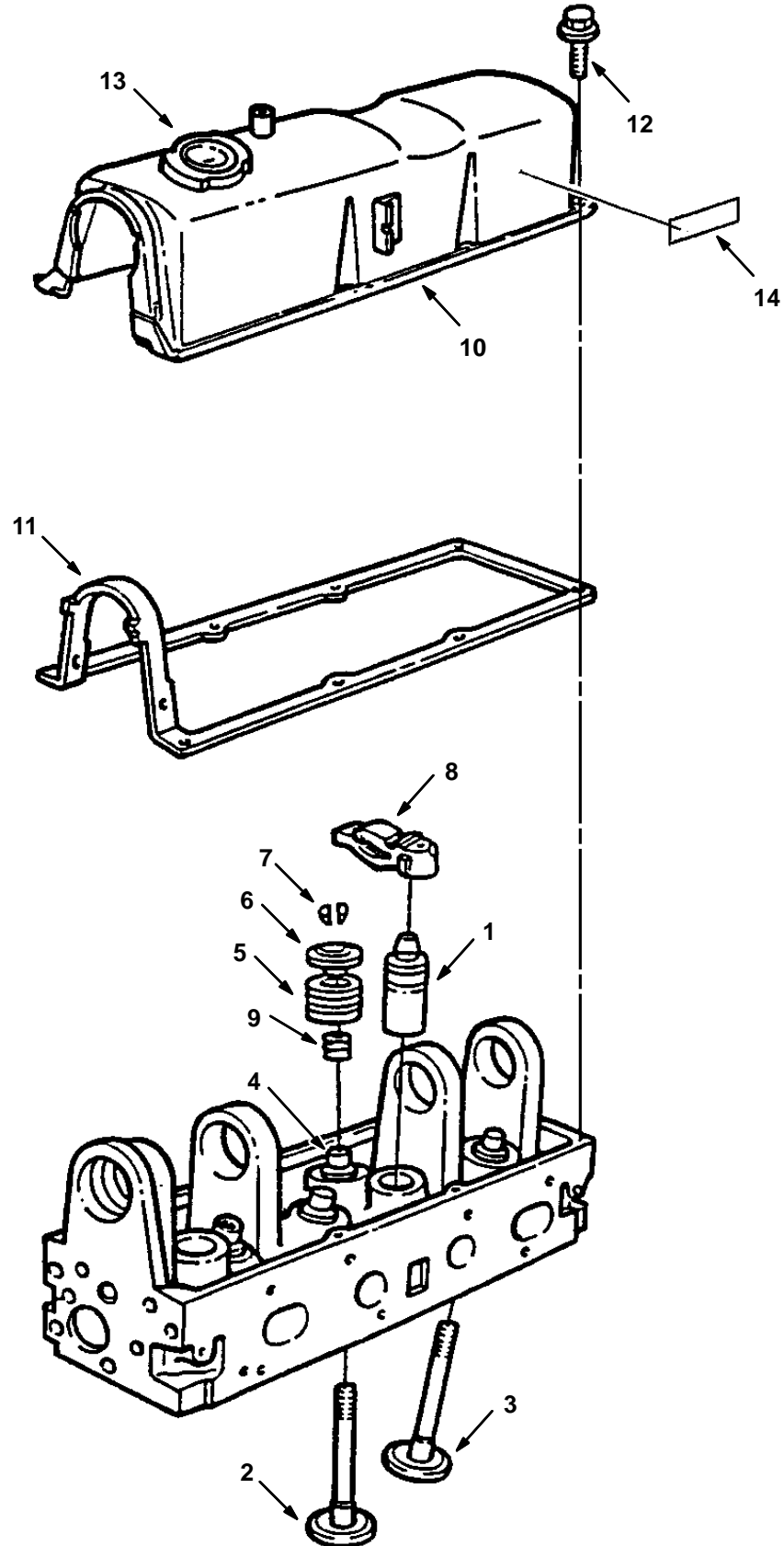
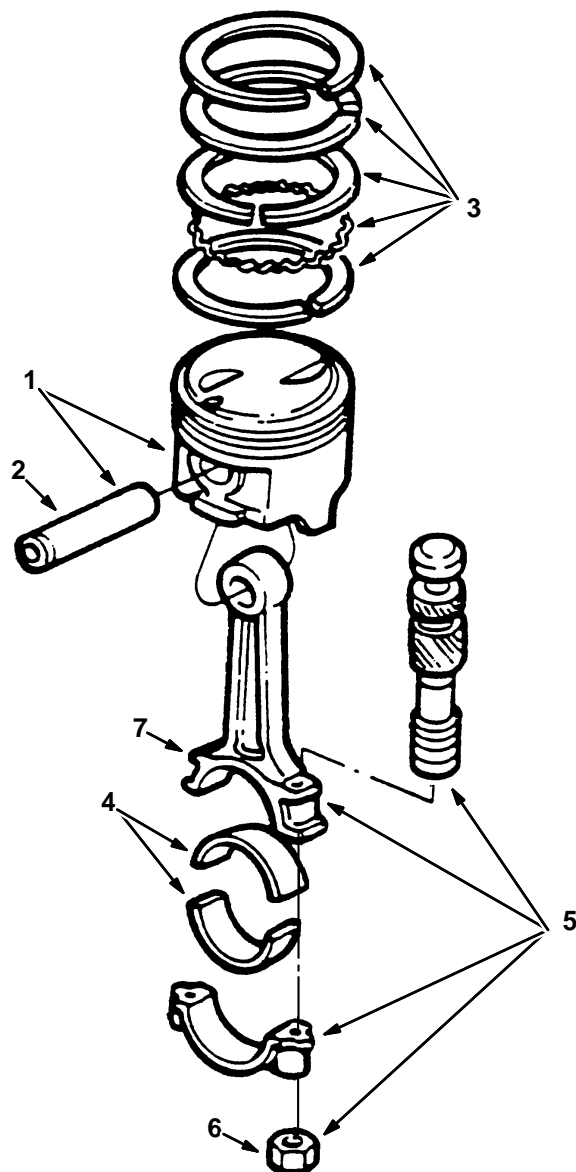

Fig. 11 – Valves And Rocker Arm Cover Group

Ref.	Tennant Part No.	Ford Part Number	Description	Qty.
1	84950	F57Z-6500-A	Tap.Assy-Valve	8
2	84951	F57Z-6505-A	Std.Exh.Valve	4
3	84952	F57Z-6507-A	Std.Int.Valve	4
4	84953	F57Z-6510-A	Valve Guide Bushing	-
5	84954	F57Z-6513-A	Valve Spring	8
6	84955	F57Z-6514-A	Valve Spring Retainer	8
7	84956	F1AZ-6518-A	Valve Spring Key	16
8	84957	F57Z-6564-A	Valve Rocker Arm	8
9	84958	F57Z-6571-A	Valve Stem Seal	8
10	84959	F57Z-6582-B	Valve Rocker Arm Cover	1
11	84960	F57Z-6584-A	Gasket,Rocker Cover	1
12	84961	N805087-S2	Scr&Wsh,M6X15.0M	8
13	60836	F3AZ-6766-B	Breather Cap	1
14	36164	C6JZ-6404-A	Warning Label, Starter	1

Fig. 12 – Piston And Connecting Rod Group



10533/10447

Ref.	Tennant Part No.	Ford Part Number	Description	Qty.
1	84911	F57Z-6108-A	Piston, Std.	4
2	84912	F57Z-6135-A	Piston Pin	4
3	84913	F57Z-6148-A	Ring Set,Std.	2
4	60812	D7FZ-6211-A	Bearing	8
4	73977	D7FZ-6211-B	Brg-Conn.Rod	-
4	73978	D7FZ-6211-C	Brg-Conn.Rod	-
4	73979	D7FZ-6211-D	Brg-Conn.Rod	-
4	73980	D7FZ-6211-E	Brg-Conn.Rod	-
4	73981	D7FZ-6211-F	Brg-Conn.Rod	-
4	73982	D7FZ-6211-G	Brg-Conn.Rod	-
∇ 5	84914	F57Z-6200-A	Connecting Rd	4
6	60813	D4FZ-6212-A	Nut, Conrod-8	8
7	60814	F2ZZ-6214-A	Bolt-Conrod-4	8

Fig. 13 – Water Pump, Thermostat and Fan Group

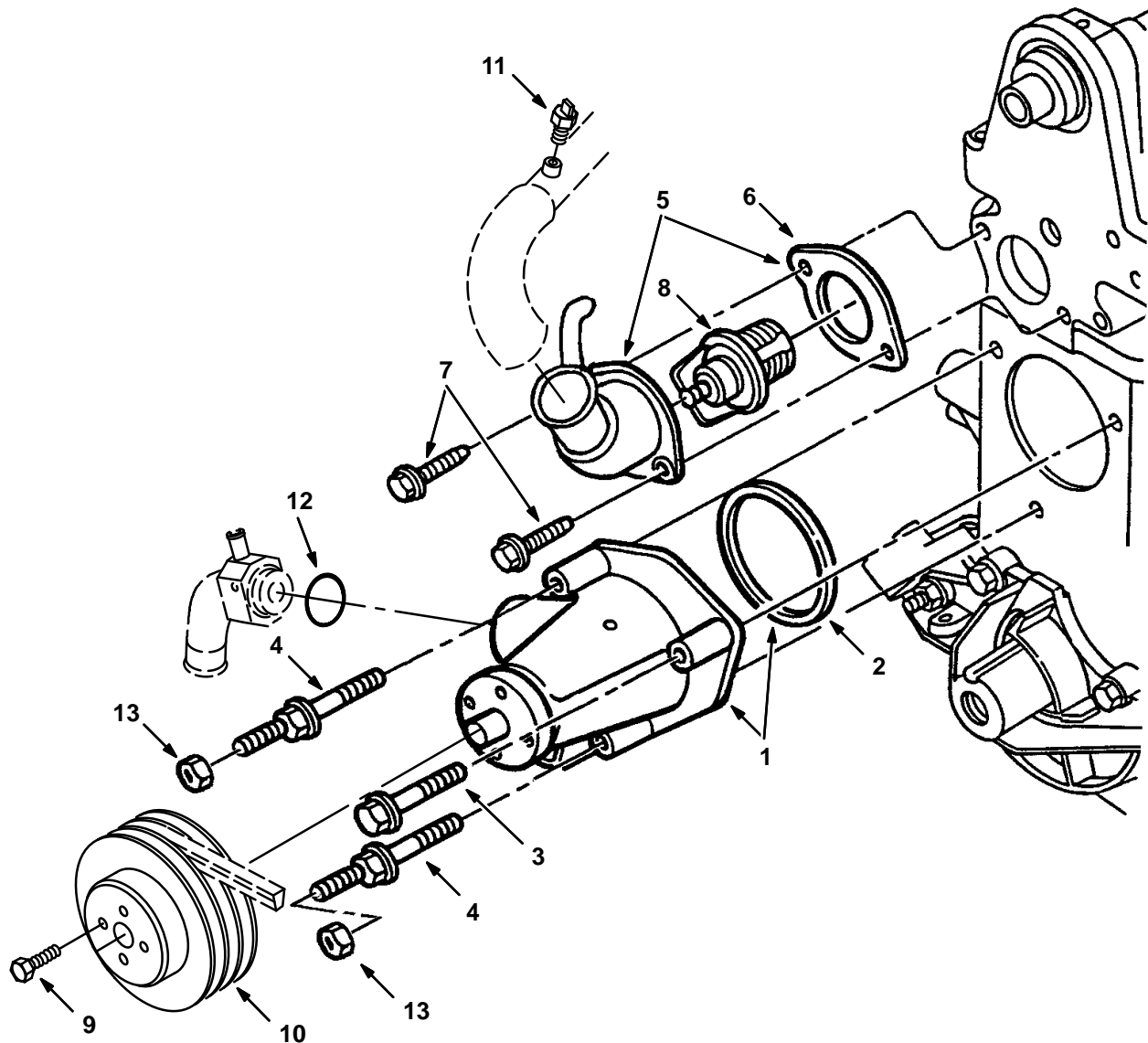

10542/10528

Ref.	Tennant Part No.	Ford Part Number	Description	Qty.
∇ 1	84982	F57Z-8501-A	Water Pump	1
2	84983	F57Z-8507-A	Gskt,Water Pump	1
3	84984	N808517-S100	Bolt,M8X53.0mm	1
4	84998	N804225-S2	Stud	2
∇ 5	73996	RH14	Water Outlet	1
6	74538	E8ZZ-8255-A	Gasket Water Outlet Connection	1
7	84988	N800025-S	Bolt,M8X18.0M	2
8	84987	F57Z-8575-A	Therm 190 W/Gsk	1
9	84994	E602184-S72	Bolt, M8X12.0mm	1
10	36014	E3ZE-8509-FA	Sheave, Water Pump	1
11	84989	F57Z-12A648-A	Temperature sensor	1
12	79975	87056-S100	O-Ring, Water Pump Adaptor	1
13	84993	MNLZ-6	Locknut	2

Fig. 14 – Ignition Group

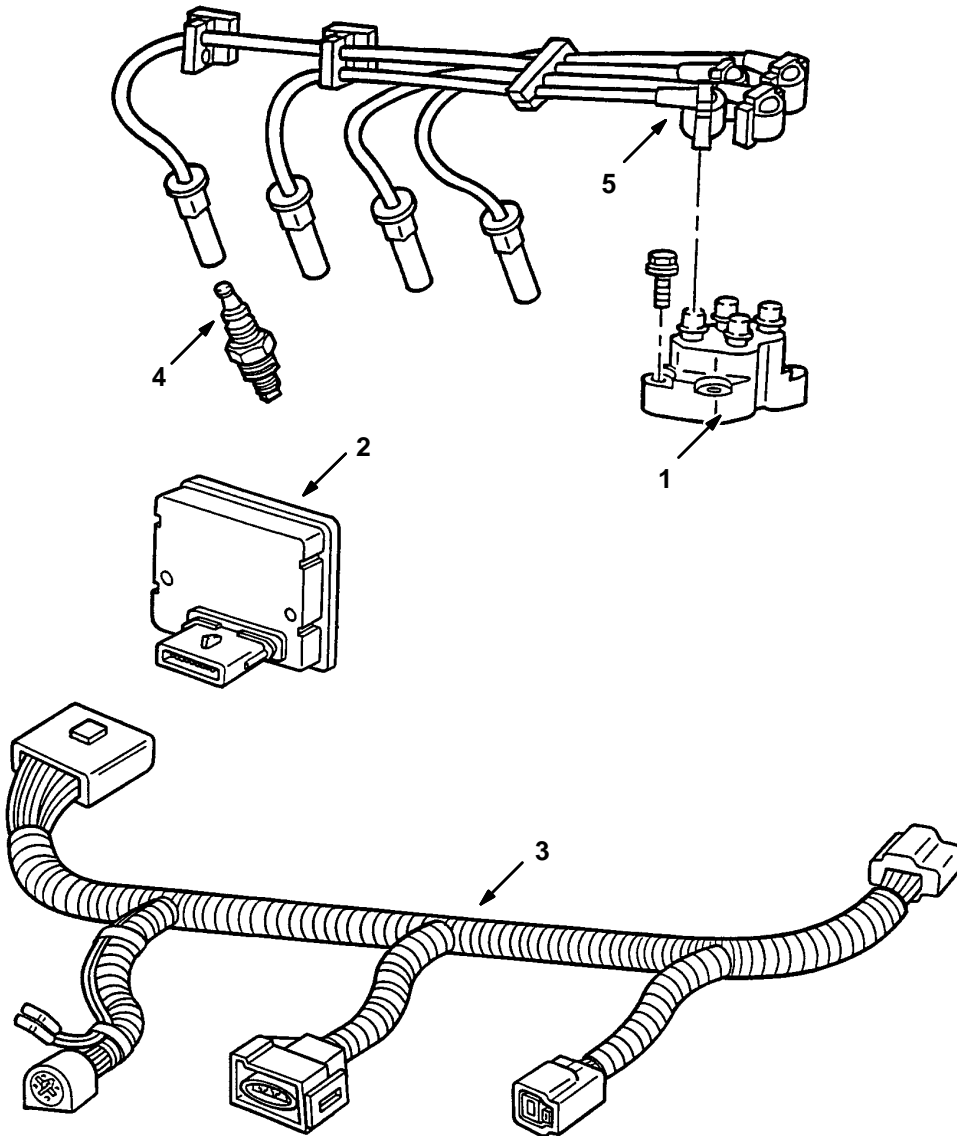

10538/10524

Ref.	Tennant Part No.	Ford Part Number	Description	Qty.
1	83732	F37Z-12029-A	Ignition Coil	1
2	83676	F5JL-12A297-DA	Ignition Module	1
3	83707	F53L-12A200-AA	Wire Harness	1
4	60846	AWSF-52-C	Spark Plug	4
5	83677	F57E-12280-BB	Wire Asy, Spark Plug	1

SECTION 7

CONTENTS

	PAGE
PART NUMBER TO PAGE NUMBER CROSS REFERENCE LIST	7-2
PART DESCRIPTION TO PAGE NUMBER CROSS REFERENCE LIST	7-23

CROSS REFERENCE

PART NUMBER TO PAGE NUMBER CROSS REFERENCE LIST

Part Number	Page Number	Part Number	Page Number
AWSF-52-C	5-23, 6-22	D4FZ-6A738-A	5-3, 5-9
B3Q-6515-A	5-17	D4FZ-6A738-B	5-3, 5-9
C2DZ-11222-A	5-21, 6-9	D4FZ-6A753-A	5-3, 5-9
C2OZ-6A616-A	5-11	D4FZ-6A753-B	5-3, 5-9
C5AZ-6026-H	5-3, 6-3	D4FZ-6B260-A	5-15
C5AZ-6026-J	5-3, 6-3	D4FZ-6B316-A	5-13
C6JZ-6404-A	6-19	D4FZ-6K254-A	5-15
C8AZ-6026-D	5-3	D4FZ-6K291-A	5-7
D42E-6E009-BB	5-5	D4FZ-6K297-B	5-13
D4FZ-6019-B	5-7	D4FZ-6L273-A	5-15, 6-17
D4FZ-6020-A	5-5, 5-7	D4FZ-9441-A	5-5
D4FZ-6020-B	5-5, 5-7	D4FZ-9E434-A	5-14
D4FZ-6108-A	5-19	D5FZ-6600-A	5-11
D4FZ-6108-B	5-19	D5TZ-12A112-B	5-23
D4FZ-6108-CB	5-19	D6AZ-11223-A	5-21, 6-9
D4FZ-6108-DB	5-19	D6FZ-6500-A	5-17
D4FZ-6108-EB	5-19	D6FZ-6500-B	5-17
D4FZ-6108-FB	5-19	D7AZ-6026-A	5-3, 5-6
D4FZ-6148-A	5-19	D7BZ-6397-A	5-3, 6-3
D4FZ-6148-B	5-19	D7FZ-12A099-A	5-23
D4FZ-6148-C	5-19	D7FZ-6211-A	5-19, 6-20
D4FZ-6148-D	5-19	D7FZ-6211-B	5-19, 6-20
D4FZ-6212-A	5-19, 6-20	D7FZ-6211-C	5-19, 6-20
D4FZ-6214-A	5-19	D7FZ-6211-D	5-19, 6-20
D4FZ-6256-A	5-9, 5-15	D7FZ-6211-E	5-19, 6-20
D4FZ-6261-B	5-6, 5-15, 6-6	D7FZ-6211-F	5-19, 6-20
D4FZ-6261-C	5-6, 5-15, 6-6	D7FZ-6211-G	5-19, 6-20
D4FZ-6278-A	5-15, 6-17	D8BZ-6378-A	6-13
D4FZ-6278-B	5-9, 6-11	D8FZ-6564-A	5-17
D4FZ-6333-A	5-13	D8FZ-9E436-B	5-5, 5-14
D4FZ-6333-B	5-13	D9AZ-6731-A	6-3
D4FZ-6333-C	5-13	D9JE-12127-BA	5-23
D4FZ-6333-D	5-13	D9JI-6379-B	6-15
D4FZ-6333-E	5-13	DOAZ-6518-A	5-17
D4FZ-6333-F	5-13	DZ-4	5-23
D4FZ-6337-A	5-13	DZ-468-A	5-23
D4FZ-6337-B	5-13	DZ-472	5-23
D4FZ-6337-C	5-13	E2JL-8A570-AA	5-22
D4FZ-6337-D	5-13	E2ZZ-6200-A	5-19
D4FZ-6337-E	5-13	E2ZZ-6303-A	5-13
D4FZ-6337-F	5-13	E3TZ-6135-A	5-19
D4FZ-6337-G	5-13	E3TZ-9424-A	5-14
D4FZ-6337-H	5-13	E3TZ-9439-A	5-14
D4FZ-6337-J	5-13	E3ZE-8509-FA	6-21
D4FZ-6337-K	5-13	E3ZZ-6019-A	5-7
D4FZ-6337-L	5-13	E3ZZ-6019-B	5-7
D4FZ-6337-M	5-13	E3ZZ-6622-A	5-11
D4FZ-6345-A	5-13, 6-3	E3ZZ-6A312-A	5-13
D4FZ-6378-A	5-13	E3ZZ-9430-A	6-14
D4FZ-6510-A	5-17	E3ZZ-9450-A	6-14
D4FZ-6571-A	5-5	E43Z-6514-A	5-17
D4FZ-6613-A	5-9, 5-15	E4FZ-6A739-A	5-9
D4Fz-6613-A	6-17	E4JL-6754-AA	6-3
D4FZ-6638-A	5-11	E4ZZ-6513-A	5-17
D4FZ-6700-A	5-5	E59Z-9439-A	5-5, 5-14
D4FZ-6A008-A	5-3, 6-3	E5BZ-12106-A	5-23
D4FZ-6A340-A	5-13	E5FZ-8590-A	5-22
D4FZ-6A618-A	5-11	E5TZ-6505-F	5-17

Part Number	Page Number	Part Number	Page Number
E5TZ-6505-G	5-17	E9OZ-11A171-A	5-21, 6-9
E5TZ-6505-H	5-17	E9OZ-11A172-A	5-21, 6-9
E5ZZ-6079-E	5-5	E9OZ-11K190-A	5-21, 6-9
E5ZZ-6250-C	5-15	E9OZ-11N087-A	5-21, 6-9
E5ZZ-6268-A	5-15	E9SZ-11091-A	5-21, 6-9
E5ZZ-6345-A	5-13, 6-3	E9TZ-6306-A	5-13
E5ZZ-6507-D	5-17	E9TZ-6K282-A	5-15
E5ZZ-6507-E	5-17	E9ZZ-6009-B	5-3
E5ZZ-6507-F	5-17	F1AZ-6518-A	6-19
E5ZZ-6701-A	5-5, 5-13	F1TZ-11002-A	5-21, 6-9
E5ZZ-6A630-A	5-3	F1TZ-11130-A	5-21, 6-9
E5ZZ-6A674-A	5-11	F1ZZ-6026-B	6-3, 6-6
E5ZZ-6A674-B	5-11	F1ZZ-6306-A	6-13
E5ZZ-9430-A	5-14	F1ZZ-6584-A	5-17
E602184-S72	6-21	F1ZZ-6700-A	5-5
E620454-S72	5-11	F1ZZ-6710-A	5-5, 5-11
E69Z-6C629-A	6-11	F1ZZ-6A340-A	6-13
E69Z-6C629-B	6-11	F1ZZ-6B316-A	6-13
E69Z-6C629-C	6-11	F2TZ-11135-A	5-21, 6-9
E69Z-7007-A	6-15	F2ZZ-6214-A	6-20
E6DZ-6026-B	6-3, 6-6	F37Z-12029-A	6-22
E6JL-6057-AA	5-17	F37Z-9448-A	6-14
E6TZ-12200-E	5-23	F3AZ-6766-B	6-19
E6ZZ-6019-A	5-7	F3DZ-6730-A	5-11, 6-11
E6ZZ-6E078-B	5-5	F3DZ-6734-A	5-11, 6-5, 6-11
E6ZZ-8501-A	5-22	F3DZ-6754-A	5-5
E7HZ-6026-E	6-17	F3VY-11390-B	5-21, 6-9
E7JE-6049-DA	5-6	F3ZZ-6051-C	6-5, 6-6
E7RY-6675-B	5-11	F3ZZ-6065-A	5-6, 6-6
E7SZ-6010-A	5-3	F4AZ-6701-A	6-5, 6-13
E7TZ-9A474-C	5-14, 6-14	F53L-12A200-AA	6-22
E7ZZ-6571-A	5-17	F572-6582-B	6-19
E7ZZ-6571-B	5-17	F57E-12280-BB	6-22
E7ZZ-6571-C	5-17	F57E-17K004-BB	6-14
E7ZZ-6571-D	5-17	F57Z-12A648-A	6-21
E7ZZ-6571-E	5-17	F57Z-6009-B	6-3
E7ZZ-6571-F	5-17	F57Z-6010-A	6-3
E7ZZ-6E008-A	5-7, 5-15	F57Z-6019-A	6-7
E8DZ-18599-B	6-14	F57Z-6019-B	6-7
E8TZ-6582-D	5-17	F57Z-6019-C	6-7
E8ZZ-6026-A	5-7, 6-7	F57Z-6020-A	6-5, 6-7
E8ZZ-6051-A	5-5, 5-6	F57Z-6049-A	6-6
E8ZZ-6626-A	5-11	F57Z-6049-B	6-6
E8ZZ-6700-A	5-5, 5-9, 5-13, 5-15, 6-5, 6-13, 6-17	F57Z-6079-A	6-5
E8ZZ-6890-A	6-3	F57Z-6108-A	6-20
E8ZZ-8255-A	5-22, 6-5, 6-21	F57Z-6135-A	6-20
E8ZZ-8507-A	5-5, 5-22	F57Z-6148-A	6-20
E97E-6A666-A2A	6-3	F57Z-6200-A	6-20
E9OZ-11005-A	5-21, 6-9	F57Z-6250-B	6-17
E9OZ-11036-A	5-21, 6-9	F57Z-6256-A	6-11, 6-17
E9OZ-11049-A	5-21, 6-9	F57Z-6268-A	6-17
E9OZ-11061-C	5-21, 6-9	F57Z-6303-A	6-13
E9OZ-11067-A	5-21, 6-9	F57Z-6333-A	6-13
E9OZ-11075-A	5-21, 6-9	F57Z-6333-B	6-13
E9OZ-11135-A	5-21, 6-9	F57Z-6333-C	6-13
E9OZ-11350-A	5-21, 6-9	F57Z-6333-D	6-13
E9OZ-11A091-A	5-21, 6-9	F57Z-6333-E	6-13
E9OZ-11A165-A	5-21, 6-9	F57Z-6333-F	6-13
E9OZ-11A167-A	5-21, 6-9	F57Z-6333-H	6-13
		F57Z-6333-J	6-13

CROSS REFERENCE

Part Number	Page Number	Part Number	Page Number
F57Z-6333-K	6-13	N605880-S309B	6-11
F57Z-6333-L	6-13	N605890-S2	6-3
F57Z-6333-M	6-13	N605892-S2	6-7
F57Z-6333-N	6-13	N606523-S2	6-11
F57Z-6337-A	6-13	N620481-S2	6-14
F57Z-6337-B	6-13	N620482-S2	6-11
F57Z-6337-C	6-13	N621906-S2	6-7
F57Z-6337-D	6-13	N800025-S	6-21
F57Z-6337-E	6-13	N800030-S53B	5-17
F57Z-6337-F	6-13	N800059-S	5-11
F57Z-6500-A	6-19	N800112-S2	5-15, 6-17
F57Z-6505-A	6-19	N801424-S36	5-14
F57Z-6507-A	6-19	N801427-S2	5-14
F57Z-6510-A	6-19	N801688-S2	5-7
F57Z-6513-A	6-19	N802209-S100	6-14
F57Z-6514-A	6-19	N804225-S2	6-21
F57Z-6564-A	6-19	N804660-S2	5-11
F57Z-6571-A	6-5, 6-19	N804958-S8	6-7
F57Z-6584-A	6-5, 6-19	N805087-S2	6-19
F57Z-6600-A	6-11	N805403-S100	5-21, 6-9
F57Z-6622-A	6-11	N805405-S36B	5-21, 6-9
F57Z-6626-A	6-5	N805406-S36B	5-21, 6-9
F57Z-6659-A	6-11	N806378-S141	6-11
F57Z-6675-A	6-11	N806379-S141	6-11
F57Z-6710-A	6-5, 6-11	N807288-S2	6-7
F57Z-6A630-A	6-3	N807419-S	6-3
F57Z-6B273-A	6-17	N807497-S2	6-7
F57Z-6B288-A	6-11	N808049-S102	6-7
F57Z-6C315-A	6-7	N808163-S100	6-14
F57Z-6E078-A	6-5	N808517-S100	6-21
F57Z-6K254-A	6-17	N808534-S2	6-7
F57Z-8501-A	6-21	RG-565	5-5
F57Z-8507-A	6-5, 6-21	RH14	5-22, 6-21
F57Z-8575-A	6-21	00500-15	4-20
F57Z-9439-B	6-5, 6-14	00954	4-23
F5JL-12A297-DA	6-22	00960	4-24
F5JL-17N090-CA	6-14	01274	2-43, 2-45, 3-21
F5JL-6750-AA	6-3	01570	3-59, 3-61
F5JL-6853-A	6-3	01987	2-125, 2-127
F5JL-9424-AA	6-14	01999	3-39
F5TZ-6626-A	6-11	02247	2-65, 2-73
F5TZ-6A785-A	6-3	02506-6	3-68
FOAZ-6766-A	5-17	02549	2-125, 2-127
FOTZ-11355-A	5-21, 6-9	02713	2-155
FOTZ-6K282-B	6-17	02742	2-69
MC-209-A	5-21, 6-9	03026	2-77, 2-79, 2-81, 2-83, 2-85, 2-87, 3-65, 3-67
MM307	3-76	03922	2-151, 2-153
MM307ES	3-76	04414	2-13, 2-15, 2-63
MM307FR	3-76	04483	4-42
MM337	3-76	04664	2-13
MNLZ-6	6-21	04706	2-157
N600313-S2	6-11	04733-4	2-33
N600414-S100	5-15, 6-17	04761	2-137, 3-35
N601313-S100	5-9	04843	2-43, 2-45, 3-59, 3-61
N602529-S2	5-7, 5-14	05611	2-155
N602551-S2	5-11	05880	2-89
N604465-S	5-9, 5-15, 6-17	05881	2-89
N605663-S100	5-22	06146	2-131
N605786-S2	6-11	06474A	2-133, 2-135
N605787-S52	6-14		

Part Number	Page Number	Part Number	Page Number
06537	2-137	19117	2-155, 4-23
07252	2-65	19459	2-121, 2-129
07449	2-119	19544	2-121
07539	2-65, 2-69	19577	2-99
07562	3-65, 3-67	19618	2-125
07873	2-91, 2-93	19774	2-55, 2-57
08085	3-25	20634	3-75
08179	2-141	21035	2-137, 3-35
09718	2-111	21041	3-61
10143	2-106, 2-107	21047	3-61
10632-11	3-11, 3-13	21054	3-61
10632-2	3-3, 3-5	21104	3-61
10632-20	3-3, 3-5, 3-7, 3-9	21109	2-141
10632-4	2-53, 3-75	21117	2-127
10632-5	2-159, 3-16, 3-41	21119	2-127
10632-9	3-15, 3-16	21131	2-19
10664	2-3, 2-105	21136	2-89
10665	2-105	21138	2-89
10723	2-55	21150	3-45
10724	2-55, 6-3	21168	2-10, 2-11
10829	2-157	21170	3-25
10911	2-131	21215	2-137
11211	2-39	21216	3-51
11442-23	2-95	21221	2-45
11531	2-97	21223	3-57
11676	3-59, 3-61	21224	2-137
11716	2-149	21230	3-65, 3-67
11747	2-43, 2-45, 3-75	21231	2-141, 3-33
11984	2-65, 2-67	21238	2-137
12263	2-17	21239	2-137
12549	3-49	21246	2-15
12976	2-61	21250	3-35
13048	2-67	21251	3-35
13173	2-63	21252	3-35
13902	4-29, 4-31, 4-33, 4-35	21253	3-35
13904	4-31, 4-33, 4-35, 4-37	21270	3-53, 4-47
13907	4-3, 4-7, 4-11, 4-15	21271	3-55, 4-51
14131	2-91, 2-93	21272	4-47, 4-51
14138A	2-17	21273	3-53
14242	2-113	21274	3-53
14432	2-77, 2-79, 2-81, 2-83, 2-85, 2-87	21275	3-53
14595-1	2-119, 3-25	21276	3-53
14601	2-65, 2-69, 2-119, 3-25	21277	3-53
14605	2-119, 2-133, 3-25	21278	3-53
15724	2-73, 2-75	21279	4-47, 4-51
15791-1	2-65, 2-73	21280	4-47, 4-51
16236	3-21	21282	2-10, 2-11
16431	2-127	21294	2-55, 2-57
16455	2-135	21295	2-55
16456	2-31, 2-33	21301	3-75
16497	2-77, 2-83	21303	2-51
16694	4-21, 4-22	21304	2-33
16695	4-20, 4-21, 4-22	21307	3-43
16738	2-65, 2-67	21308	3-43
17414	2-55, 2-57, 2-73, 2-75	21309	3-43
17808	2-113	21310	3-43
17809	2-113	21311	3-45
17980	2-131, 2-133, 2-135, 3-35	21312	3-45
19035	3-59, 3-61	21313	3-45
		21642	2-19

CROSS REFERENCE

Part Number	Page Number	Part Number	Page Number
21643	2-19	32006	2-51
21671	3-71	32009	2-51
21689	2-105	32133	3-53
21695	2-105	32134	3-53
21721	2-41	32147	3-53
21722	2-41	32151	4-45, 4-47, 4-49, 4-51
21917	4-28, 4-29, 4-35	32492	3-33
22022	2-9	32822	3-19, 3-23
22023	2-9	33404	2-145
22290	2-157	33799	2-125, 2-127
22297	2-77, 2-79, 2-81, 2-83, 2-85, 2-87, 3-65, 3-67	33817	2-129
22308-3	2-95	34065	2-57
23146	3-59, 3-61	34072	2-73, 2-75
23156	2-73, 2-75	34159	4-5, 4-9, 4-13, 4-17
23498	2-153, 3-19	34176	4-20
24047	2-95	34178	4-19
24576-1	3-15, 3-16	34179	4-19
24576	3-15, 3-16	34180	4-19
24899	2-143	34181	4-19
24924	2-65, 2-67	34182	4-19
24928-1	2-95	34183	4-19
25312	3-69	34184	4-19
25610	2-93	34185	4-19
26395-1	2-53	34306	2-3, 2-129
26395-2	2-65, 3-59, 3-61	34330	2-143
26496	2-95	34355	2-125, 2-127
26565	3-61	34359	2-111, 2-145
27048	2-95	34360	2-125, 2-127
27768	2-77, 2-79, 2-83, 2-85, 3-65, 3-67	34365	2-61
29233	3-7, 3-9, 3-15	34379	2-125, 2-127
29260	2-17, 3-25	34390	2-129
30013	2-133, 2-135	34392	2-39, 2-41
30251	2-143	34690	2-7
30252	2-143	34864	2-53, 3-75
30253	2-143	34996	2-65
30255	2-143	34997	2-65
30389	2-67, 2-75	35033	2-129
30480	2-65, 3-25	351826-S	5-23
30481	2-65, 2-69	352532-S	5-3
305015-S	5-23	35323	2-5
30533	3-72	35324	2-5
31038	2-57	35325	2-5
31182	2-17	35326	2-5
31354	4-20, 4-21	35327	2-5
31380	4-21, 4-22	35336	2-5
31385	4-21, 4-22	35424	3-65, 3-67
31504	2-151, 2-153	35493	4-27
31525	3-57	35529	2-31, 2-33
31526	2-57	356214-S8	5-13
31563	2-127	35688	2-39, 2-41
31597	3-38	35705	5-23
31599	2-103, 2-105	35716	5-23
31605	2-131	35719	5-23
31613	2-3, 2-129	35753	2-55
31755	2-99, 2-101	35980	2-59, 2-61, 2-63
31775	2-117	35983	2-55
31989	2-65, 2-69	35992	2-55
31999	2-51	35993	2-3, 2-55
		36006	2-55
		36008	2-55

Part Number	Page Number	Part Number	Page Number
36011	2-55	41128	3-53, 3-55
36012	2-55	41130	2-151, 2-153
36014	2-55, 6-21	41131	2-141
36015	2-55	41141	3-41
36020	2-65	41178	2-10, 2-11, 2-15
36021	2-65, 2-67, 2-69, 2-71	41186	3-33
36023	2-59, 2-61	41341	2-147
36024	2-59, 2-61	41434	3-49
36026	2-65, 2-69	42124	3-59, 3-61
36032	2-55	42207	2-137
36035	2-65, 2-73	42215	2-129, 2-133, 2-135
36037	2-55	42226	2-155
36041	2-65	42260	2-25, 2-129
36045	2-55	43242	3-21
36046	2-55	43363	2-9
36048	6-14	43454	2-53, 3-75
36050	2-65, 2-67, 2-93	43500	2-3, 2-7, 2-9
36085	2-55	43555	2-51, 2-77, 2-79, 2-81, 2-83, 2-85, 2-87, 3-19, 3-23, 3-25, 3-51, 3-65, 3-67
36158	3-59, 3-61	43609	2-55, 2-59, 2-61
36159	2-65, 2-73	43844	2-67, 2-71, 2-77, 2-79, 2-83, 2-85, 2-91, 3-65, 3-67
36164	6-19	44078	2-157
36165	2-55, 2-57	44681-1	3-5, 3-9, 3-13
36173	2-133	44681-2	3-5, 3-9, 3-13
36192	2-25	44681	3-5, 3-9, 3-13
36268	5-3, 5-6, 5-15, 6-3, 6-6	44777	2-13, 2-15
36328	2-137, 3-35	44853	3-21
36438	3-15, 3-16	44868	2-131, 2-133, 3-35
36439	3-15, 3-16	44869	2-131, 2-135, 2-143, 2-155
36548	3-53	44906	2-137, 3-35
36556	2-135	44961	3-75
36758	2-7, 2-9	45272	3-3, 3-5, 3-7, 3-9, 3-11, 3-13
37127	6-11	45482	2-131, 3-35
37157	6-5, 6-11	45622	4-19
37301	6-3	45623	4-19
373118-S	5-9, 5-15	45628	4-20, 4-21, 4-22
37460	4-3, 4-7, 4-11, 4-15	45779	3-3, 3-5, 3-7, 3-9, 3-11, 3-13
37462	4-3, 4-7, 4-11, 4-15	45780	2-7, 2-9
37555	4-21, 4-22	45786	2-115
37723	4-19	46236	2-117, 3-75
37766	4-19	46481	2-103, 2-105, 2-121
37943	4-19	46482	2-31, 3-33
39005	3-65, 3-67	46611	2-69, 2-73, 2-75
391202-S	6-17	47313A	2-65, 2-67
39210	2-31, 2-33, 2-39, 2-41, 2-129, 2-133	47395	2-95
39309	2-65, 2-69	47504	2-135, 2-141
39338	3-31	47508	2-121, 2-137, 3-35
39527	4-20	47512	2-31, 2-33, 2-103, 2-105, 2-133
39703-2	2-3, 2-55	47585	2-157
39923	2-53, 3-75	47637	3-35
40131	2-47	47638	2-31, 2-33, 2-133, 2-135
40282	2-47	47720	2-95
40380	4-19	47752	2-133
40514	2-129		
40585	2-93		
40607	2-53, 2-73, 2-75, 3-75		
40678	3-75		
40716	2-13, 2-15		
41073	2-111		
41074	2-111		

CROSS REFERENCE

Part Number	Page Number	Part Number	Page Number
47753	3-35	54333	2-65, 2-73
48267	2-91, 2-93	54400	2-139, 3-31
48813	4-27	54615	2-13, 2-15, 3-65, 3-67
48842	3-76	54663	2-139, 3-31
49263	2-137, 2-157, 3-35	54848	2-139, 3-31
49266	2-53, 3-3, 3-5, 3-7, 3-9, 3-11, 3-13, 3-75	54878	2-143
49282	2-15	54911-30	2-55
49933	2-133, 2-135	54911-32	2-65, 2-73, 6-3
50270	2-147	54912-8	2-69
50332-1	2-65, 2-69	54930	2-73
50332-2	2-65, 2-69	55042	4-45, 4-47, 4-49, 4-51
51021N	2-5	55248	3-3, 3-5, 3-7, 3-9, 3-11, 3-13
51109	2-117	55586	2-143
51176	2-13, 2-15	55685	2-133, 2-135
51193	2-113	55686	2-31, 2-33
51305	2-99, 2-101	55700	2-127
51322	2-25	55779	2-143
51338	2-113	55998	2-73
51340	2-111	56186	2-161, 3-3, 3-5, 3-7, 3-9, 3-11, 3-13, 3-75
51341	2-111	56346	2-159
51373	2-113	56398	2-157
51448	2-143	56506	2-9
51449	2-143	56624	2-139, 2-141, 3-31, 3-33
51483	2-117	56690	2-131, 2-133, 2-141, 2-157, 3-33, 3-35
51531	3-59, 3-61	56692	2-121, 2-155
51534	2-145	56820	2-111, 2-141, 3-33
51542	2-5	56821	2-155
51545	2-117	56976A	2-95
51560-5	2-77, 2-79, 2-81, 2-83, 2-85, 2-87, 3-65, 3-67	57048	2-59, 2-61, 2-63
51562	2-117	57152	4-25
51564	2-143	57167	2-161
51693	2-147, 2-149	57173	2-125, 2-127
51745	3-65, 3-67	57297	2-95
51787	2-25, 2-43, 2-45	57311	2-117
51813	2-141, 3-33	57411	2-133, 2-135
51839	2-73, 2-75	57483	2-125
51963	2-5	57485	2-125, 2-127
52296	3-31	57543	2-151
52402	2-103, 2-105, 2-135, 2-155	57564	2-13
52580-2	2-77, 2-79, 2-81, 2-83, 2-85, 2-87	57751	2-161
52911	2-121	57772	2-141
52992	2-77, 2-79, 2-81, 2-83, 2-85, 2-87	57773	2-59, 2-61, 2-63
53029	2-71	57792	2-103
53268	2-73, 2-75	57803	2-161
53400-1	2-95	57807	2-141, 2-159, 3-33
53400-4	2-95	57820	2-13, 2-15, 2-23
53434	2-143, 4-20	57934	2-67
53461-2	2-17, 2-19, 2-21, 2-23	57936	2-27, 2-29, 2-31, 2-33
53601	2-111, 4-42	57941	2-7, 2-9
54009	3-59, 3-61	57944	2-127
54012	3-59, 3-61	57963	2-125, 2-127, 3-39
54096	2-145	57988	2-133, 2-135
54194	2-73	57993	2-131
54222	2-119	57994	2-129
54274	2-155	58012	4-18
54275A	2-155	58013	4-18
		58114	2-153

Part Number	Page Number	Part Number	Page Number
58228	2-99, 2-101, 2-151, 2-153	60804	5-5, 5-7
58242	4-18	60805	5-6
58270	4-20	60806	5-6, 6-5, 6-6
58278	4-20	60807	5-5
58279	2-139, 3-31, 3-33	60808	5-5
58293	2-27, 2-29	60809	5-19
58357	2-51	60810	5-19
58359	2-31, 2-33	60812	5-19, 6-20
58489	2-10, 2-21, 2-23	60813	5-19, 6-20
58494	2-17, 2-19, 2-139, 3-31	60814	5-19, 6-20
58518	3-3, 3-7, 3-11	60815	5-15
58519	3-3, 3-7, 3-11	60816	5-9, 5-15
58520	3-3, 3-7, 3-11	60817	5-6, 5-15, 6-6
58524	2-43, 2-45	60818	5-15
58589	2-95	60819	5-13
58590	2-95	60821	5-13
58596	4-25, 4-26	60822	5-13
58844	2-11, 3-65, 3-67	60823	5-13
58858	2-121, 2-129	60824	5-13
58898	2-10, 2-11	60825	5-13
59015	2-93	60826	5-13
59192	2-21, 2-23, 3-65, 3-67	60827	5-17
59195	2-43	60828	5-17
59305	4-18	60829	5-17
59375	2-57	60830	5-17
59577	2-131	60831	5-17
59633	2-51	60832	5-11
59661	2-17, 2-19, 2-25	60833	5-5, 5-9, 5-13, 5-15, 6-5, 6-13, 6-17
59668	2-119	60834	5-5, 5-13
59672	2-119	60836	5-17, 6-19
59703	2-17, 2-19	60838	5-22
59734	2-101	60839	5-22
59767	2-184	60844	5-23
59807	2-73	60845	5-23
59808	2-73, 2-75	60846	2-3, 5-23, 6-22
59919	3-19	60847	5-17
59921	3-75	60875	5-23
59954	3-75	60933	3-65, 3-67
59962	2-139, 3-31	60934	3-65, 3-67
59965	2-29, 3-15, 3-16	60938	2-59, 2-61, 5-21, 6-9
59970	2-159	61288	2-129
59971	2-159	61303	2-65
59974	2-159	61363	2-55, 2-57
59976	2-159	61424	3-41
59977	2-159	61490	4-20, 4-21, 4-22
59978	2-159	61529	2-55, 2-57
59979	2-159	61531	2-55, 2-57
60090	2-61	61854	2-55
60292	2-106, 2-107	61869	2-73
60293	2-106, 2-107, 2-109	61870	2-73
60559	2-55, 2-57	61871	2-55
60714	2-55	61875	3-76
60716	2-65, 2-73	61882	4-3, 4-7, 4-11, 4-15
60717	2-65	61886	4-5, 4-9, 4-13, 4-17
60718	2-65, 2-73	61920	3-15, 3-16
60725	2-73, 2-75	61927	4-27
60732	2-143	61931	2-55, 2-57
60745	3-65, 3-67	61945	2-65
60802	5-3	61969	2-159
60803	5-5, 5-7		

CROSS REFERENCE

Part Number	Page Number	Part Number	Page Number
62172	2-133, 2-135	63527	2-131, 4-31
62173	2-133, 2-135	63535	2-59, 2-61, 2-63
62389	2-121	63540	2-111
62424	2-59, 2-61, 6-15	63541	2-143
62548	2-121, 4-3, 4-5, 4-11, 4-13	63542	2-103, 2-105, 4-24
62561	2-121, 4-18	63543	2-111
62564	2-137, 3-35, 4-21	63544	2-7, 2-9
62565	2-157, 4-25	63551	2-119
62567	2-133, 4-36	63583	2-31, 2-33
62595-18	3-11, 3-13, 3-15, 3-16	63584	2-31, 2-33
62595-2	2-13, 2-15	63585	2-31, 2-33
62595-3	2-15	63589	2-39
62954	2-3, 2-7, 2-9	63591	2-111
62955	2-3, 2-7, 2-9	63599	2-103
62956	2-3, 2-7, 2-9	63632	2-47
62957	2-3, 2-7, 2-9	63647	2-35, 2-37
62960	2-7	63648	2-35
62975	2-31, 2-33, 4-43	63662	2-47
62985	2-27	63663	2-7, 2-9
62988	2-27	63665	2-35, 2-37
62990	2-27	63667	2-35, 2-37
62991	2-27	63668	2-35, 2-37
62992	2-27, 2-29	63669	2-35, 2-37
62993	2-27, 2-29, 2-31	63671	2-47, 2-49
62996	2-27, 2-29	63673	2-35
63055	2-59, 2-61	63676	2-47
63068	2-59, 2-61	63677	2-47
63107	2-59	63695	2-63
63154	2-59	63710	2-13
63191	2-99	63751	2-13, 2-15
63205	2-91	63776	2-27, 2-29
63218	2-115	63810	2-65, 2-67, 2-73, 2-75
63226	3-70	63818	2-99, 2-101
63228	3-70, 3-71	63850	2-115
63233	2-51	63926	2-27, 2-29
63234	2-51	63968	2-129
63263	2-59, 2-61, 2-63	64034	2-145
63275	2-119	64037	2-55
63276	2-119	64058	2-115
63279	2-103, 2-105	64059	2-115
63280	2-103, 2-105	64132	2-145
63281	2-113	64156	2-31, 2-33
63286	2-113	64165	2-133
63290	2-113	64166	2-133
63292	2-119	64175	2-133
63294	2-13, 2-15	64176	2-133
63295	2-117	64228	2-131
63297	2-51	64232	2-39
63311	2-51	64233	2-145
63378	2-39, 2-45	64278	2-17, 2-19
63407	3-73	64279	2-17, 2-19
63416	2-39, 3-35	64299	2-99, 2-151, 2-153
63417	2-176	64312	2-17, 2-19
63426	2-111, 4-19	64320	3-19, 3-23
63436	2-143	64392	2-51
63449	2-143	64394	2-51
63450	2-143	64406	2-99
63471	2-111	64410	2-51
63491	2-111	64419	2-25
63496	2-111	64434	2-133, 2-135

Part Number	Page Number	Part Number	Page Number
64440	2-17	65201	2-125, 2-127
64500	2-51	65202	2-125, 2-127
64501	2-51	65204	2-125, 2-127
64543	2-21, 2-23	65205	2-125, 2-127
64545	2-21, 2-23	65208	2-125
64550	2-117	65209	2-125
64554	2-117	65210	2-125
64556	2-117	65211	2-125
64558	2-117	65212	2-125, 2-127
64559	2-51	65213	2-125, 2-127
64567	2-51	65215	2-129
64580	2-51	65220	2-103
64586	2-157	65221	2-103, 2-105
64595	2-17, 2-19	65222	2-103, 2-105, 3-57
64618	2-51, 2-99, 2-101, 2-151, 2-153	65223	2-31
64621	2-51, 2-99, 2-101, 2-151, 2-153	65224	2-125, 2-127
64631	2-157	65226	4-18
64632	2-119	65227	4-19
64635	2-117	65232	4-21, 4-22
64648	2-151	65233	4-25
64651	2-157	65234	4-25
64655	2-157	65235	4-25, 4-26
64726	2-17, 2-19	65236	4-25
64744	2-17, 2-19	65237	4-25
64788	2-3, 2-10, 2-11	65238	4-25
64801	2-10	65239	2-155
64802	2-11	65240	4-31, 4-33, 4-35
64811	2-143	65242	2-157, 4-26
64812	2-147	65245	2-159
64873	2-51	65246	2-119
64874	2-51	65248	2-145
64884	2-13, 2-15	65249	2-145
64886	2-111	65252	2-25
64887	2-111	65258	3-17
64893	2-39, 2-41	65278	2-43, 2-45
64905	2-133, 2-135	65281	2-43, 2-45
64919	2-3, 2-7, 2-9	65285	2-43
64920	2-3, 2-7, 2-9	65287	2-39
64923	2-10, 2-11	65290	2-43
64950	2-117	65294	2-139
65003	2-17	65302	2-39
65129	2-117	65391	2-155, 3-35, 4-27
65145-1	2-121	65527	2-73, 2-75
65148	2-59, 2-61	65561	2-141, 3-33
65158	2-89	65869-5	2-3
65160	2-137, 3-35	67310	2-111, 2-121
65168	2-137	67555-S	5-23
65170	2-137	67683	3-35
65173	2-137, 3-35	67767	2-31, 2-33, 2-111
65174	2-137, 2-141, 3-33, 3-35	68445	3-49
65180	2-137, 3-35	68869	2-109
65188	2-125, 2-127	68872	2-106, 2-107
65191	2-125, 2-127	68873	2-106, 2-107
65194	2-125, 2-127, 3-39	69097	2-71
65195	2-125, 2-127	69582	2-139, 3-31
65196	2-125, 2-127	69904	2-7, 2-9
65197	2-125, 2-127	69906	2-43, 2-45
65199	2-125, 2-127	69918	3-19, 3-23
		69937	3-19, 3-23
		69981	3-19, 3-23

CROSS REFERENCE

Part Number	Page Number	Part Number	Page Number
70006	2-129	70631	2-89
70072	2-129	70633	2-97
70160	2-55, 2-57	70635	2-97
70173	2-93	70636	2-97
70387	2-55	70639	2-81, 2-83, 2-85, 2-87
70388	2-35, 2-37	70641	2-65
70398	2-161	70643	2-83, 2-85
70400	2-176, 2-183	70645	2-91
70401	2-91	70649	2-5
70402	2-161	70650	2-51
70407	2-21, 2-23	70651	2-51
70408	2-17, 2-19	70652	2-151
70410	2-21	70659	3-59, 3-61
70411	2-161	70666	2-107
70431	2-137, 3-35	70668	3-59, 3-61
70435	2-95	70669	3-17
70444	2-139, 3-31	70684	3-27
70450	2-13, 2-15	70686	3-26
70451	2-7	70690	3-72
70453	2-3, 2-10, 2-11	70692	3-69
70454	3-17	70696	3-15
70459	2-31	70699	3-41
70461	2-103	70703	2-103, 2-105
70472	2-43	70704	2-13, 2-15
70477	2-91, 2-93	70705	2-184
70478	2-13, 2-15	70708	2-107
70504	2-117	70709	2-157
70505	2-117	70710	2-99
70506	2-117	70711	2-99
70511	2-117	70712	2-99, 2-101
70514	2-31, 2-33	70715	2-139
70517	2-7, 2-9	70717	2-157
70521	2-137	70718	2-95
70523	2-31	70719	2-95
70524	2-137, 3-35	70720	2-139
70525	2-137, 3-35	70721	2-139
70526	2-137, 3-35	70723	2-65, 2-69
70528	2-47	70725	2-119
70532	2-47, 2-137, 3-35	70730	2-43, 2-45
70536	2-184	70742	2-43, 2-45
70538	2-5	70744	2-99
70539	2-106	70747	2-119
70540	2-106	70749	2-119
70541	2-106	70754	2-97
70550	2-117	70755	2-97
70552	2-25	70756	2-13, 2-15, 3-21
70564	2-13, 2-15	70761	2-43, 2-45, 3-49
70583	2-145	70762	2-43, 2-45
70595	2-43	70767	2-91
70596	2-17, 2-19	70775	2-155
70597	2-10	70780	2-131
70598	2-11	70783	2-119
70620	2-13	70784	2-151
70622	2-157	70785	3-43
70623	2-157	70788	3-43
70626	2-137, 3-35	70790	2-155
70627	2-137, 3-35	70793	3-27, 3-28, 3-29
70628	2-21, 2-23	70797	3-31
70629	2-91	70802	3-27, 3-28, 3-29
70630	2-91	70808	2-11

CROSS REFERENCE

Part Number	Page Number	Part Number	Page Number
70809	2-10	73689	3-19, 3-23
70810	2-155	73691	2-13
70815	3-27, 3-28, 3-29	73692	3-19
70819	2-77, 2-79, 2-83, 2-85	73700	3-19, 3-23
70825	2-151, 2-153	73709	3-19
70827	2-133, 2-135	73714	2-139, 3-31
70832	2-89	73717	3-53
70836	3-65, 3-67	73722	2-7
70838	2-77, 2-83, 3-67	73724	2-7, 2-9
70843	2-7, 2-9	73725	2-83, 2-85
70844	2-7, 2-9	73727	2-53
70847	2-133, 2-135	73731	2-111
70849	2-73, 2-75	73732	2-21
70851	2-43, 3-75	73733	2-111
70852	2-43	73734	2-51
70853	2-43	73735	2-77, 2-83
70854	2-39	73736	2-31
70855	2-39	73737	2-139, 2-141, 3-31, 3-33
70857	2-151	73742	2-83, 2-85, 2-87
70858	2-103	73748	2-35
70859	2-103	73749	2-35, 2-37
70869	2-77, 2-79, 2-81, 2-83, 2-85, 2-87	73751	3-7
70870	3-21	73753	3-9
70871	3-21	73755	3-3
70876	2-67, 2-71, 2-77, 2-79, 2-83, 2-85	73757	3-5
70877	2-151	73759	3-11
70878	3-21	73761	3-13
70879	3-21	73762	2-147
70885	3-27	73771	2-35, 2-37
71025	3-19, 3-23	73772	2-35, 2-37
71552	2-125, 2-127	73788	2-83, 2-85
71558	2-61	73789	2-83, 2-85, 2-87
72968	3-65, 3-67	73792	2-83
72979	2-75	73793	2-77
73018	2-75	73794	2-77
73020	2-75	73795	2-77, 2-79
73140	2-101	73796	2-77, 2-79
73645	2-7, 2-9	73818	2-139, 3-31
73646	2-151, 2-153	73841	2-17
73648	2-10	73843	2-17
73649	2-11	73856	2-139
73650	2-151, 2-153	73858	3-53
73653	3-19, 3-23	73860	2-139
73654	2-3, 2-10, 2-11	73862	2-7, 2-9
73655	3-21	73863	2-7, 2-9
73656	3-21	73870	2-3, 2-10, 2-11
73660	3-21	73871	3-59, 3-61
73661	3-21	73877	3-59
73663	3-21	73878	3-59
73664	3-21	73880	3-59, 3-61
73671	3-21	73883	3-59
73674	3-21	73884	3-59
73675	3-19	73887	2-37
73677	3-19, 3-23	73888	2-3, 2-10, 2-11
73678	2-35, 2-37	73893	2-17
73679	2-35, 2-37	73898	3-3, 3-5, 3-7, 3-9
73685	2-151, 2-153	73899	3-3, 3-5, 3-7, 3-9
73688	3-27	73901	2-13, 2-15
		73903	2-13, 2-15
		73912	5-23

CROSS REFERENCE

Part Number	Page Number	Part Number	Page Number
73913	5-3	73974	5-3, 5-6
73914	5-13	73975	5-3, 6-3
73915	5-9, 5-15	73976	5-19
73916	5-23	73977	5-19, 6-20
73917	5-3, 6-3, 6-14	73978	5-19, 6-20
73918	5-17	73979	5-19, 6-20
73919	5-11	73980	5-19, 6-20
73920	5-3, 6-3	73981	5-19, 6-20
73921	5-3, 6-3	73982	5-19, 6-20
73922	5-3	73983	5-15
73923	5-23	73990	5-17
73924	5-5	73992	5-5, 5-14
73925	5-14	73993	5-23
73926	5-7	73994	5-14
73927	5-6, 6-6	73995	5-5, 5-17
73928	5-19	73996	5-22, 6-21
73929	5-19	73997	5-19
73930	5-19	73998	5-14
73931	5-19	73999	5-7
73932	5-19	74000	3-3, 3-5, 3-7, 3-9, 3-11, 3-13
73933	5-19	74005	2-147
73934	5-19	74007	3-17
73935	5-19	74009	2-151
73936	5-6, 5-15, 6-6	74015	2-43, 2-45
73937	5-15, 6-17	74022	2-117
73938	5-13	74023	2-151
73939	5-13	74025	2-147
73940	5-13	74031	2-139, 3-31
73941	5-13	74038	2-7
73942	5-13	74040	2-17, 2-19
73943	5-13	74042	2-103
73944	5-13	74045	2-35, 2-37
73945	5-13	74046	2-35, 2-37
73946	5-13	74051	2-119
73947	5-13	74052	2-119
73948	5-13	74058	2-97
73949	5-13	74059	2-137, 3-35
73950	5-13, 6-3	74060	2-137
73951	5-13	74062	2-10
73952	5-17	74063	2-11
73953	5-5	74064	2-7, 2-9
73954	5-9, 5-15, 6-17	74066	2-7, 2-9
73956	5-11	74067	2-7, 2-9
73957	5-5	74068	2-139
73958	5-3, 6-3	74069	2-37
73959	5-13	74070	2-47
73960	5-11	74074	3-59, 3-61
73961	5-3, 5-9	74076	2-55, 2-57
73962	5-3, 5-9	74081	2-13, 2-15
73963	5-3, 5-9	74083	3-59
73964	5-3, 5-9	74089	2-95
73965	5-15	74090	2-139, 2-141, 3-31, 3-33
73966	5-13	74091	3-55, 4-49
73967	5-15, 6-17	74094	4-21, 4-22
73968	5-7	74098	4-31, 4-33, 4-35
73969	5-13	74100	4-21, 4-22
73970	5-15, 6-17	74101	4-21, 4-22
73971	5-5	74106	4-25
73972	5-23	74109	4-25, 4-26
73973	5-17		

Part Number	Page Number	Part Number	Page Number
74110	4-25, 4-26	74279	4-5, 4-9, 4-13, 4-17
74111	4-25, 4-26	74280	4-3, 4-7, 4-11, 4-15
74112	4-25, 4-26	74281	4-3, 4-7, 4-11, 4-15
74113	4-25	74282	4-5, 4-9, 4-13, 4-17
74114	4-25	74283	4-7, 4-9, 4-15, 4-17
74115	4-25	74284	4-5, 4-13
74116	4-25	74285	4-11, 4-15, 4-39
74118	4-25	74286	4-3, 4-11
74126	4-36	74287	4-3, 4-11
74128	4-36	74288	4-3, 4-11
74129	4-36	74289	4-3, 4-11
74130	4-36	74391	2-141
74131	4-36	74402	2-71
74132	4-19	74443	2-65, 2-67, 2-71
74133	4-19	74506	5-7
74134	4-19	74507	5-11
74135	4-19	74508	5-13
74136	4-19	74509	5-14, 6-14
74137	4-19	74510	5-5
74145	4-29, 4-31	74511	5-5, 5-14
74146	4-31, 4-33, 4-35	74512	5-11
74163	2-121, 4-7, 4-9	74513	5-5
74164	3-73, 4-15, 4-17	74514	5-17
74174	4-26	74515	5-17
74182	4-26	74516	5-13, 6-3
74184	4-3, 4-7, 4-11, 4-15	74517	5-17
74190	4-26	74518	5-17
74194	4-26	74519	5-3
74210	4-3, 4-7, 4-11, 4-15	74520	5-11
74218	4-26	74521	5-11
74223	4-3, 4-7, 4-11, 4-15	74522	5-11
74224	4-3, 4-11	74523	5-17
74233	4-23, 4-24	74524	5-7
74240	4-3, 4-7, 4-11, 4-15	74525	5-11
74250	4-21, 4-22	74527	5-14, 6-14
74251	4-26	74528	5-17
74253	4-7, 4-15	74529	5-17
74254	4-7, 4-15	74530	5-17
74256	4-3, 4-7, 4-11, 4-15	74531	5-17
74257	4-3, 4-7, 4-11, 4-15	74532	5-17
74258	4-7, 4-15	74533	5-17
74259	4-5, 4-9, 4-13, 4-17	74534	5-7, 5-15
74260	4-5, 4-9, 4-13, 4-17	74535	5-17
74261	4-5, 4-9, 4-13, 4-17	74536	5-7, 6-7
74262	4-3, 4-7, 4-11, 4-15	74537	5-5, 5-11
74263	4-7, 4-15	74538	5-22, 6-5, 6-21
74264	4-9, 4-17	74539	5-5, 5-22
74265	4-3, 4-7, 4-11, 4-15	74540	5-13
74266	4-3, 4-7, 4-11, 4-15	74541	5-3
74267	4-3, 4-7, 4-11, 4-15	74543	5-5, 5-11
74268	4-31, 4-33, 4-35	74545	5-15, 6-17
74270	4-5, 4-9, 4-13, 4-17	74546	5-7, 5-14
74271	4-5, 4-9, 4-13, 4-17	74547	5-11
74272	4-3, 4-7, 4-11, 4-15	74548	5-9, 5-15, 6-17
74273	4-3, 4-7, 4-11	74549	5-22
74274	4-5, 4-9, 4-13, 4-17	74550	5-17
74275	4-5, 4-9, 4-13, 4-17	74551	5-11
74276	4-3, 4-7, 4-11, 4-15	74552	5-15, 6-17
74277	4-5, 4-9, 4-13, 4-17	74553	5-14
74278	4-5, 4-9, 4-13, 4-17	74554	5-14

CROSS REFERENCE

Part Number	Page Number	Part Number	Page Number
74555	5-7	75833	3-57
74556	5-11	75843	2-47
74557	5-22	75852	2-39
74559	5-5, 5-11	75854	2-93
74560	5-9	75857	2-139, 3-31
74561	5-9, 6-11	75859	2-139, 3-31
74562	5-9	75860	2-15
74867	2-47	75866	3-53
74868	2-47	75870	3-31
74899	2-139, 3-31	75875	3-51
74920	2-9	75876	3-59, 3-61
74944	2-97	75877	3-59, 3-61
75010	2-5	75880	3-49
75011	2-5	75881	3-49
75012	2-39, 2-41	75882	3-49
75022	3-31	75883	3-65, 3-67
75023	3-31	75884	3-53, 3-55
75028	2-137	75890	3-51
75046	2-43, 2-45	75891	2-31, 2-33
75047	2-43, 2-45	75892	3-31
75082	3-31	75893	2-139
75092	3-31	75894	2-139, 3-31
75099	3-35	75898	3-53
75117	3-35	75899	3-35
75128	2-17, 2-19, 3-65, 3-67	75900	3-53
75142	3-35	75901	3-63
75192	3-51	75968	2-157
75282	3-31	75989	3-63
75303	3-65, 3-67	76030	3-63
75304	3-51	76036	3-63
75305	2-119	76038	3-63
75456-1	2-151, 2-153	76049	3-63
75456-2	2-151, 2-153	76055	3-63
75456-3	2-151, 2-153	76069	3-63
75456-4	2-151, 2-153	76074	3-63
75456	2-151, 2-153	76081	3-63
75465	2-53, 3-75	76084	3-63
75491	3-31	76100	3-63
75519	3-67	76235	2-29
75537	3-31	76237	2-29
75568	3-15, 3-16	76245	3-55
75573	3-11, 3-13	76285	2-15
75575	2-117	76286	3-59, 3-61
75606	3-51	76316	2-129
75609	3-51	76319	2-77, 2-79, 2-81, 2-83, 2-85, 2-87
75612	2-143	76321	2-77, 2-79, 2-81, 2-83, 2-85, 2-87, 3-65, 3-67
75666	3-51, 3-65, 3-67	76335	2-77, 2-79, 2-81, 2-83, 2-85, 2-87
75667	2-47	76338	3-59, 3-61
75689	3-23	76339	2-139
75701	3-59, 3-61	76382	2-89
75768	2-59, 2-61	76383	2-89
75820	3-43	76384	2-37
75821	3-45	76385	3-41
75822	3-43	76404	3-11, 3-13, 3-15
75823	3-43	76406	3-59, 3-61
75824	3-43	76415	3-15, 3-16
75825	3-43	76427	2-119, 3-15, 3-16
75827	2-47		
75828	3-57		
75829	3-57		

CROSS REFERENCE

Part Number	Page Number	Part Number	Page Number
76437	3-53, 3-55	77392	2-45
76438	2-137	77394	2-45
76448	3-21	77400	2-45
76453	2-119	77423	3-15
76460	3-15	77425	2-61
76461	3-35	77430	2-61, 2-63
76464	2-9	77434	2-61, 2-63
76465	2-9	77435	2-61, 2-63
76470	2-29	77437	2-61
76471	2-29	77447	2-101
76473	3-53	77452	2-101
76474	2-37	77458	3-33
76487	2-37	77459	2-141, 3-33
76490	2-117	77463	2-29
76491	2-117	77467	2-23
76492	2-15	77469	2-23
76495	2-15	77470	2-23
76497	2-125, 2-127	77471	2-51
76498	2-125, 2-127	77473	2-127
76499	2-125	77479	2-49
76522	3-43	77482	2-49
76523	2-119	77485	2-135
76529	2-41	77488	2-135
76555	2-9	77489	3-65, 3-67
76575	3-19, 3-23	77490	2-109
76578	3-19, 3-23	77491	2-135
76615	2-125	77492	2-135
76619	2-139	77493	2-135
76620	2-79, 2-81, 2-85, 2-87	77495	2-135, 4-37
76633	2-85, 2-87	77498	2-135
76639	2-117	77499	2-135
76647	2-119	77516	2-49
76653	2-117	77517	4-45, 4-47
76684	3-38, 3-39	77519	3-28
76736	2-91, 2-93	77520	3-28
76870	3-65, 3-67	77523	2-49
76871	2-49	77527	2-105
76895	2-49	77528	2-101
76898	3-49	77529	2-101
76906	2-129	77530	2-105
76907	2-91, 2-93	77531	2-153
76936	2-41	77532	2-153
76945	3-23	77537	3-25
76948	3-43	77538	3-25
76950	3-43	77542	3-25
76971	3-43	77545	3-28
76973	3-43	77553	2-153
76975	3-45	77555	3-57
76976	3-45	77558	2-93
76977	3-43	77568	2-141, 3-33
76980	3-43	77569	3-33
76982	3-43	77575	2-131
76985	3-43	77578	2-149
76996	3-43	77579	2-109
77097	2-39, 2-41, 2-131, 2-141, 2-145, 2-155, 3-33	77580	2-149
77340	2-15	77584	2-141, 3-33
77388	2-45	77587	2-65
77390	2-45	77591	2-153
77391	2-45	77593	2-9
		77597	2-141, 3-33

CROSS REFERENCE

Part Number	Page Number	Part Number	Page Number
77599	2-141, 3-33	77806	3-47
77600	2-141, 3-33	77807	3-47
77601	2-141	77808	3-47
77602	2-109	77809	3-47
77605	2-141, 2-149	77810	3-43
77611	3-26	77811	3-43
77613	3-26	77812	3-43
77629	3-25	77813	3-43
77630	2-23	77814	3-43
77631	3-19, 3-23	77815	3-43
77632	2-3	77816	3-45
77634	2-3	77817	3-45
77640	2-127	77818	3-45
77641	2-127	77819	3-45
77642	2-23	77820	3-45
77646	2-117	77821	3-45
77662	3-25	77822	3-45
77665	3-23	77823	3-45
77669	2-141	77824	3-45
77670	3-25	77825	4-45, 4-49
77671	3-25	77826	4-45, 4-49
77674	3-53	77827	4-45, 4-47, 4-49, 4-51
77675	3-53, 4-45	77828	4-45, 4-47, 4-49, 4-51
77680	2-9	77829	4-45, 4-47
77682	2-141	77830	4-45, 4-47, 4-49, 4-51
77690	2-7	77831	4-45, 4-47
77703	3-65, 3-67	77832	4-45, 4-47, 4-49, 4-51
77704	3-65, 3-67	77833	4-45, 4-47
77706	3-65, 3-67	77834	4-49, 4-51
77707	3-65, 3-67	77835	4-45, 4-47, 4-49, 4-51
77708	3-65, 3-67	77839	4-45, 4-47, 4-49, 4-51
77710	3-65, 3-67	77840	4-45, 4-47
77712	3-65, 3-67	77841	4-45, 4-47, 4-49, 4-51
77726	3-36	77842	4-45, 4-47, 4-49, 4-51
77727	2-141, 3-33	77843	4-45, 4-47
77728	2-19	77844	4-45, 4-47
77734	2-9	77845	4-45, 4-47
77738	3-33	77846	4-45, 4-47, 4-49, 4-51
77742	3-23	77847	4-45, 4-47, 4-49, 4-51
77743	3-19	77848	4-45, 4-47
77745	2-176	77849	4-45, 4-47, 4-49, 4-51
77755	3-63	77869	3-53
77759	3-63	77872	4-45, 4-47, 4-49, 4-51
77770	2-113	78043	2-93
77771	2-141, 3-33	78122	2-95
77777	2-9	78812	2-65
77778	3-65, 3-67	78880	2-75
77780	2-33	78996	2-131, 4-33
77782	2-9	78997	2-79, 2-81, 2-85, 2-87
77783	3-33	78998	3-39
77786	3-65	78999	2-111, 2-113
77787	3-65, 3-67	79002	2-19
77788	2-105	79009	2-19
77790	2-113	79010	2-9
77800	3-47	79012	3-19
77801	3-47	79019	2-45
77802	3-47	79025	3-75
77803	3-47	79026	3-75
77804	3-47	79028	2-15, 2-149
77805	3-47	79032	2-3

CROSS REFERENCE

Part Number	Page Number	Part Number	Page Number
79038	2-3	79646	3-61
79115	2-141, 3-33	79647	3-61
79116	2-119	79648	2-159
79117	2-141	79650	3-23
79122	2-153	79670	2-9
79123	2-137	79671	2-9
79124	3-35	79674	3-61
79138	2-41	79680	2-9
79139	2-37	79681	2-9
79140	2-111	79688	4-45, 4-47, 4-49, 4-51
79151	2-113	79689	4-45, 4-47
79153	2-111, 2-113	79690	4-49, 4-51
79155	3-75	79692	4-45, 4-47, 4-49, 4-51
79156	3-75	79694	4-45, 4-47, 4-49, 4-51
79157	3-75	79695	4-45, 4-47
79158	3-75	79697	4-45, 4-47
79159	3-75	79698	4-45, 4-47
79160	3-75	79699	4-45, 4-47
79167	3-75	79703	4-3, 4-11
79168	3-75	79704	4-5, 4-13
79169	3-75	79705	4-5, 4-13
79170	3-75	79706	4-3, 4-11
79172	3-75	79707	4-3, 4-11
79174	3-75	79708	4-9, 4-17
79176	3-75	79709	4-3, 4-5, 4-11, 4-13
79177	3-75	79711	4-28, 4-29, 4-31, 4-33, 4-35
79181	2-49	79719	4-29, 4-31, 4-33, 4-35
79399	2-55, 2-57	79720	4-31, 4-33
79448	2-65, 2-69	79728	4-29, 4-31, 4-33, 4-35
79513	3-11, 3-13, 3-16	79731	4-28, 4-31, 4-33, 4-35
79514	2-111	79739	4-28, 4-31, 4-33, 4-35
79554	3-16	79740	4-28, 4-29, 4-31, 4-33, 4-35
79587	2-45	79742	4-3, 4-7, 4-11, 4-15
79591	2-45	79743	4-7, 4-15
79593	2-117	79744	4-7, 4-15
79594	2-117	79745	4-7, 4-15
79596	2-41	79746	4-7, 4-15
79597	2-37	79747	4-7, 4-15
79600	2-37	79748	4-5, 4-9, 4-13, 4-17
79608	2-9	79749	4-5, 4-9, 4-13, 4-17
79620	3-65, 3-67	79750	4-5, 4-9, 4-13, 4-17
79621	3-35	79751	4-5, 4-9, 4-13, 4-17
79622	3-35	79752	4-5, 4-9, 4-13, 4-17
79624	3-65, 3-67	79753	4-5, 4-9, 4-13, 4-17
79625	3-65, 3-67	79754	4-41
79626	3-65, 3-67	79755	4-39, 4-41
79628	5-21, 6-9	79756	4-39, 4-41
79629	5-21, 6-9	79757	4-39, 4-41
79630	5-21, 6-9	79758	4-39, 4-41
79631	5-21, 6-9	79759	4-41
79632	5-21, 6-9	79760	4-39, 4-41
79633	5-21, 6-9	79761	4-39, 4-41
79634	5-21, 6-9	79762	4-39, 4-41
79635	5-21, 6-9	79763	4-39, 4-41
79636	5-21, 6-9	79764	4-39, 4-41
79638	5-21, 6-9	79765	4-39, 4-41
79639	5-21, 6-9	79766	4-39, 4-41
79640	5-21, 6-9	79767	4-39, 4-41
79642	2-127		
79644	3-61		

CROSS REFERENCE

Part Number	Page Number	Part Number	Page Number
79771	4-7, 4-15	82814	2-125
79772	4-39	82820	2-125, 2-127
79773	4-39	82825	2-39, 2-41
79774	4-39	82839	2-119
79775	4-39	82843	2-125, 2-127
79776	4-39, 4-41	82921	2-15
79777	4-39	82962	3-59, 3-61
79778	4-39	83547	2-49
79779	4-3, 4-7, 4-11, 4-15	83548	2-49
79781	2-137, 3-35, 4-22	83549	2-29
79782	4-22	83551	2-29
79783	4-43	83553	2-29, 2-33
79784	4-43	83554	2-29, 2-33
79786	4-37	83555	2-33
79787	4-37	83557	3-29
79788	4-37	83618	2-41
79789	4-37	83620	2-49
79790	4-37	83622	2-49
79791	4-37	83626	3-29
79792	4-37	83627	3-29
79793	4-37	83643	2-93
79794	4-37	83644	2-93
79795	4-37	83645	3-53
79797	4-37	83646	3-65, 3-67
79798	4-37	83652	2-57
79799	4-37	83662	2-63
79812	4-37	83664	2-57
79820	4-37	83669	6-15
79822	4-37	83670	2-63
79823	4-37	83672	2-63
79824	4-37	83673	2-63
79956	5-21, 6-9	83674	2-63
79957	5-21, 6-9	83676	6-22
79958	5-21, 6-9	83677	6-22
79959	5-21, 6-9	83678	2-67
79960	5-21, 6-9	83679	2-71
79961	5-21, 6-9	83686	2-67, 2-71
79962	5-21, 6-9	83689	2-63
79963	5-21, 6-9	83690	2-97
79964	5-21, 6-9	83691	2-97
79965	5-21, 6-9	83692	2-57
79966	5-21, 6-9	83693	2-183
79967	5-21, 6-9	83695	2-183
79969	5-21, 6-9	83699	3-37
79970	5-21, 6-9	83706	3-75
79972	6-14	83707	6-22
79973	6-14	83726	3-53
79974	6-14	83729	2-57
79975	6-21	83731	2-57
79976	6-14	83732	6-22
82063	3-3, 3-7, 3-11	83741	2-81, 2-87
82125	2-7, 2-9	83747	3-65, 3-67
82168	2-119	83750	2-57
82200	3-5, 3-9, 3-13	83768	2-57
82334	2-17	83853	2-57
82661	2-89	83854	2-81, 2-87
82679	2-69	84014	2-131, 4-35
82731	2-55, 2-57, 3-25	84015	2-155, 3-35, 4-28
82733	2-155	84016	2-141, 3-33, 4-29
82739	2-53, 3-75	84875	6-3

CROSS REFERENCE

Part Number	Page Number	Part Number	Page Number
84876	6-3	84940	6-13
84877	6-3	84941	6-13
84878	6-3	84942	6-13
84879	6-3	84943	6-13
84880	6-3	84944	6-13
84881	6-3	84945	6-13
84882	6-3	84946	6-13
84883	6-3	84947	6-13
84884	6-3	84948	6-15
84885	6-5	84950	6-19
84886	6-5	84951	6-19
84887	6-5	84952	6-19
84888	6-5	84953	6-19
84889	6-5, 6-11	84954	6-19
84891	6-5	84955	6-19
84892	6-5	84956	6-19
84893	6-5	84957	6-19
84894	6-5	84958	6-19
84895	6-7	84959	6-19
84896	6-7	84960	6-19
84897	6-7	84961	6-19
84898	6-7	84962	6-3
84899	6-7	84963	6-11
84900	6-7	84964	6-11
84901	6-7	84965	6-11
84902	6-7	84966	6-11
84903	6-7	84967	6-11
84904	6-7	84968	6-11
84905	6-7	84969	6-11
84906	6-7	84970	6-11
84907	6-6	84971	6-11
84908	6-6	84972	6-11
84910	6-6	84973	6-11
84911	6-20	84974	6-11
84912	6-20	84975	6-11
84913	6-20	84976	6-11
84914	6-20	84977	6-11
84915	6-17	84978	6-11
84916	6-17	84979	6-11
84917	6-17	84980	6-11
84919	6-17	84981	6-11
84920	6-17	84982	6-21
84921	6-17	84983	6-5, 6-21
84923	6-13	84984	6-21
84924	6-13	84985	6-14
84925	6-13	84987	6-21
84926	6-13	84988	6-21
84927	6-13	84989	6-21
84928	6-13	84990	6-14
84929	6-13	84991	6-14
84930	6-13	84992	6-14
84931	6-13	84993	6-21
84932	6-13	84994	6-21
84933	6-13	84995	6-14
84934	6-13	84996	6-14
84935	6-13	84997	6-14
84936	6-17	84998	6-21
84937	6-13	84999	5-21, 6-9
84938	6-13	85307	3-76
84939	6-13	86034	2-117

CROSS REFERENCE

Part Number	Page Number
86041	2-55, 2-57
86328	2-137, 3-35
86331	3-3, 3-5, 3-7, 3-9
86333	3-15
86860	2-7, 2-9
86953	2-119
87056-S100	6-21
87071-S100	6-11
87072-S100	6-11
87246	3-21, 3-25
87337	3-72
87396	2-91, 2-93
87414	2-129
87515	2-7, 2-9
87536	2-159
87583	2-161
87631	2-143
87837-S	5-3, 5-6, 5-15
87838-S101	5-3, 6-3, 6-14
87866	2-159
87889-S	6-14
8A-8115-A	6-3
97476-S2	5-21, 6-9

PART DESCRIPTION TO PAGE NUMBER CROSS REFERENCE LIST

A

A/C Hose #10 R12 De, 3-53
 A/C Hose #6 134A De, 3-53
 A/C Hose #6 R12 De, 3-53
 A/C Hose #8 R12 De, 3-53
 Actuator, Ele, Governor, 2-65, 2-69
 Actuator, Valve En, 4-9, 4-17
 Actuator, Valve En, 4-5, 4-13
 Adapter, Carburetor, Ford 2.3, 2-67, 2-71
 Adaptor Weldm., Side Brush 1.0B, 2-5
 Adaptor Wldt, Vac Wand, 3-59, 3-61
 Adaptor, Carb, 2-65, 2-69
 Adaptor, Elbow, Carb, Gas, 2-67
 Adaptor, Filter, 1/8 Npt, 2-79, 2-81, 2-85, 2-87, 3-65, 3-67
 Adaptor, Molded 2.25B, 2-79, 2-81, 2-85, 2-87
 Adaptor, Molded 2.50B, 3-65, 3-67
 Adaptor, Molded Donaldson 2.25B, 2-77, 2-83
 Adaptor, Water Pump Machined, 2-57
 Adaptor, Neutral En, 4-39
 Air Cleaner Assy, Air Cond, 3-51
 Air Cleaner, 2-77, 2-79, 2-81, 2-83, 2-85, 2-87, 3-65, 3-67
 Air Conditioner 134R Recirc (See Breakdowns), 3-53
 Air Conditioner 134R Recirc, 4-47
 Air Conditioner, A 134 (Repl. By 21270) (See Breakdowns), 3-53
 Air Conditioner, A 134 (Repl. by 21270), 4-45
 Alternator, 50A/12V Mando, 2-55, 2-57
 Alternator, 3-57
 Alum. Dryer Line De, 4-45, 4-47
 Angle Wldt, 3-53
 Angle, Bolt, Latch, Cover, 2-17, 2-19
 Angle, Bolt, Latch, 2-21, 2-23
 Angle, Cable Keeper, 2-139, 3-31
 Angle, Dust Seal, 2-35, 2-37
 Angle, Mount, 2-45
 Angle, Mtg, Shroud, Lh, 2-103
 Angle, Mtg, Shroud, Rh, 2-103
 Angle, Mtg, 2-95
 Angle, Retainer, Lip, 2-35, 2-37
 Angle, Retainer, Seal, 2-10, 2-11

Angle, Stiffener, 2-99
 Angle, Top, 2-99
 Angle, 2-59, 3-61
 Arm Alternator, 2-57
 Arm Wldt, Hopper Lift, 2-27, 2-29
 Arm Wldt, M Br, Idler, 2-143
 Arm Wldt, M Br, Motor, 2-143
 Arm. Thr. Ball, 5-21, 6-9
 Arm, Control En, 4-3, 4-7, 4-11, 4-15
 Arm, Couple, 3-21
 Arm, Rear Wiper, 3-43
 Arm, Safety, 2-27, 2-29
 Arm, Wldt, Outlet, 3-21
 Arm, 5-17
 Armature, 5-21, 6-9
 Armature, 5-23

B

Back Plate Assembly, 4-18
 Backplate S/A En, 4-9, 4-17
 Backplate S/A En, 4-5, 4-13
 Baffle – Cylinder Block Ventilation, 5-3
 Baffle, 6-3
 Ball En, 4-39
 Ball Joint .375–24, 3-59
 Ball Joint .375–24, 3-61
 Ball Joint, 250–28, 2-119, 3-25
 Ball, Check Cl, 4-25
 Ball, 4-19
 Balljoint .375–24 Lh, 3-59
 Balljoint .250–28 Ball Stud, 2-65, 2-69
 Balljoint .250–28 Body/Clip, 2-65, 2-69
 Balljoint .250–28, 2-65, 2-69
 Balljoint .375–24 Lh, 3-61
 Balljoint M 6X1.0, 2-17
 Balljoint, Rod End, 2-111
 Band, Mtg, 2-83
 Band, Mtg., 2-77, 2-79, 2-81, 2-85, 2-87, 3-65, 3-67
 Bar Wldt, Brush Pressure, 2-143
 Bar Wldt, Pivot, 2-119
 Bar, Arm, Lower, Machining, 2-29

CROSS REFERENCE

Bar, Cylinder End, 2-31, 2-33
Bar, Equalizer, 2-117
Bar, Frame, 2-9
Bar, Lower Arm, Machining, 2-27
Bar, Prop, 3-59, 3-61
Bar, Retainer, Dust Seal, 2-35, 2-37
Bar, Retainer, 2-15
Bar, Shaker Stem, 2-51
Battery, 12V, Cc Amps:600 Wet, 2-106, 2-107
Battery, 12V, Wet, 2-109
Bearing – Front – .015 U/S, 5-9
Bearing – Front – Standard, 5-3, 5-9
Bearing – Front 0.015 U/S, 5-3
Bearing – Rear .015 U/S, 5-9
Bearing – Rear – Standard, 5-3, 5-9
Bearing – Rear 0.015 U/S, 5-3
Bearing , 5-21, 6-9
Bearing Cam,, 6-6
Bearing Camshaft – .016 U/S, 5-6
Bearing Camshaft – 0.016 U/S, 5-15
Bearing Camshaft – Standard, 5-6, 5-15
Bearing Thrust, 4-21, 4-22
Bearing, .016 Camshaft, 6-6
Bearing, Connecting Rod 0.002 U/S, 5-19
Bearing, Connecting Rod 0.010 U/S, 5-19
Bearing, Connecting Rod 0.020 U/S, 5-19
Bearing, Connecting Rod 0.030 U/S, 5-19
Bearing, Connecting Rod 0.040 U/S, 5-19
Bearing, Connecting Rod Standard, , 5-19
Bearing, Connecting Rod Standard, Red , 5-19
Bearing, Control Shaft, 2-133
Bearing, Fiberglide .50 X .50, 2-51
Bearing, Fiberglide, 2-119
Bearing, Flange .500B, 2-157
Bearing, Flange .625 Bore, 2-43, 2-45, 3-59, 3-61
Bearing, Flange .875 Bore, 2-137, 3-35
Bearing, Journal, 2-31, 2-33, 2-39, 2-41
Bearing, Needle, 4-25, 4-26
Bearing, Nylon .50B, 2-135
Bearing, Nylon, 2-43, 2-45, 3-75
Bearing, Self Aligning, 2-139, 3-31
Bearing, Thrust .500, 2-7, 2-9
Bearing, Thrust – Fiberglide, 2-51
Bearing,Ball.669B 1.575D .472W, 2-55, 2-57
Bearing&Clr ,1.25B 2.44D 1.41W, 2-143
Bearing–Ball,1.38B 2.83D 0.67W, 2-143
Bearing–Cone, 1.38Bore 0.72Wth, 2-113
Bearing–Cone, 1.50Bore 0.75Wth, 2-113
Bearing–Cone, 2.63Bore 0.87Wth, 2-111
Bearing–Cup , 4.33Dia 0.74Wth, 2-111
Bearing–Cup, 2.56Dia 0.55Wth, 2-113
Bearing–Cup, 2.72Dia 0.59Wth, 2-113
Bearing–Flange,2 Hole 0.50Bore, 2-157
Bearing–Journal, 2-27, 2-29, 2-31, 2-33
Bearing, 2-51, 2-137, 2-139, 2-141, 3-31, 3-33, 3-35,
4-3, 4-5, 4-7, 4-9, 4-11, 4-13, 4-15, 4-17, 4-20,
6-20
Bearng–Journal, 2-27, 2-29
Bell Crank En, 4-39
Bell Crank, 4-41
Belt, Seat, 3-72
Belt, Timing 129 Teeth, 5-15
Belt, V .47, 45.1 Long, 3-57
Belt, V, Hc 38–46.375, 2-57
Belt–V, .47, 42.50Lg, 2-55
Binary Press. Switch, 4-45, 4-47
Blade Arm, Rear, 3-43
Blade, Deflector, 2-3, 2-7, 2-9
Block Assy – W/1 Piece Pan Gasket, 5-3
Block Assy , 6-3
Block, 3-33
Blower, 4-45, 4-47, 4-49, 4-51
Body and Gear Kit, .50 CIR, 4-18
Body and Gear Kit, .66 CIR, 4-18
Bolt – M12 – 1.75 x 100, 5-6
Bolt – M12X1.75X80, 5-13
Bolt – M12X45 – Sprocket to Camshaft, 5-15
Bolt – M14x1.5x40 – Pulley To Crankshaft, 5-13
Bolt – M6X12, 5-9
Bolt – M6X17, 5-7
Bolt – M6X20, 5-7, 5-14
Bolt – M6x27.5, 5-11
Bolt – M8 x 50, 5-22
Bolt – M8X29 , 5-14
Bolt – M9x55, 5-19

Bolt – Tensioner Spring, 5-15
 Bolt – Tensioner To Head, 5-15
 Bolt Carr.38–16X2.00, 2-99
 Bolt M12 , 6-3, 6-6
 Bolt M12X45 , 6-17
 Bolt, Hook, Rh, 2-17, 2-19
 Bolt, Latch, 2-10, 2-11
 Bolt, M6X16.5mm , 6-3
 Bolt, M8 X 17 Schd , 6-7
 Bolt, M8X12.0mm, 6-21
 Bolt,M10X40.0mm , 6-11
 Bolt,M10X45.0mm, 6-15
 Bolt,M10X55.0M, 6-14
 Bolt,M14X55.0M , 6-13
 Bolt,M5X20.0M , 6-11
 Bolt,M6X27.5mm , 6-11
 Bolt,M6X37.5mm , 6-7
 Bolt,M6X47.5mm , 6-11
 Bolt,M6X52.5mm , 6-11
 Bolt,M8X18.0M , 6-21
 Bolt,M8X20.0mm , 6-11
 Bolt,M8X25.0mm, 6-14
 Bolt,M8X53.0mm , 6-21
 Bolt,Tens.Sprn, 6-17
 Bolt–Conrod–4 , 6-20
 Bolt–Eye M8–1.25, 2-137, 3-35
 Bolt–Thru , 5-21, 6-9
 Bolt, 4-19, 6-17
 Boot, Alternator, 2-55
 Boot, Packard Electric (Altern, 2-57
 Boot, Str .42ID .12H .25L, 2-57
 Boot,Batt.Term. 1–2Ga. Red, 2-106, 2-107
 Boot,Batt.Term.1–2Ga. Black, 2-106, 2-107
 Boot–Circuit Breaker, 2-161
 Box, A/C (Repl. by 21281), 4-45
 Box, A/C, 4-47, 4-49, 4-51
 Box, Mounting, Lever, Vac, 3-61
 Brace Wldt, Bumper, Se, 3-27, 3-28, 3-29
 Bracket Weldt, Alternator, Top, 2-55
 Bracket Wldt., Mtg., Alternator, 2-55
 Bracket Wldt, Alternator Mtg, 2-57
 Bracket Wldt, Alternator, Top, 3-57
 Bracket Wldt, Cab, Lpg, 3-43
 Bracket Wldt, Eng/Alt Mount, 2-63
 Bracket Wldt, Fan Inlet, 2-151, 2-153
 Bracket Wldt, Gas Spring, 2-17
 Bracket Wldt, Lift, Cylinder, 2-145
 Bracket Wldt, Lift, 3-35
 Bracket Wldt, Mounting, Valve, 2-135
 Bracket Wldt, Mtg, Eng, Lh, 2-63
 Bracket Wldt, Mtg, Eng, Rear, 2-61
 Bracket Wldt, Mtg, Gas, Lh, 2-61
 Bracket Wldt, Mtg, Gas, Rh, 2-61
 Bracket Wldt, Mtg, Headlight, 2-49
 Bracket Wldt, Mtg, Valve, 2-133
 Bracket Wldt, Mtg,Headlamp,Lh (Replaced by 77388), 2-43
 Bracket Wldt, Mtg,Headlamp,Rh (Replaced by 77388), 2-43
 Bracket Wldt, Oper Comp, 2-13
 Bracket Wldt, Pivot, 3-35
 Bracket Wldt, Steering Tilt, 2-157
 Bracket Wldt, Tank, Lpg, 2-95
 Bracket Wldt, 3-19, 3-23, 3-31, 3-63
 Bracket, Adjuster, Brake, 2-117
 Bracket, Adjusting, Spring, 2-119
 Bracket, Angle, 2-137, 3-33, 3-35, 3-41
 Bracket, Battery, 2-107, 2-109
 Bracket, Blower Mount, 4-45, 4-47, 4-49, 4-51
 Bracket, Brace, Center, 2-17, 2-19
 Bracket, Brush Lift, Main, 2-145
 Bracket, Cable Keeper, 2-139, 3-31
 Bracket, Channel, 2-139, 3-19, 3-31
 Bracket, Dipstick Tube, 2-55
 Bracket, Eng Mtg Rh, 2-63
 Bracket, Flasher, 3-15, 3-16
 Bracket, Front, Lh, 3-65, 3-67
 Bracket, Front, Rh, 3-65, 3-67
 Bracket, Hose, Blower, 3-19, 3-23
 Bracket, L. H., 2-43
 Bracket, L, 2-39
 Bracket, Lh, 2-45
 Bracket, Lift, 2-137
 Bracket, Mounting Dir Cont, 2-119
 Bracket, Mounting Filter, 2-105

CROSS REFERENCE

- Bracket, Mounting Motor, 2-155
Bracket, Mounting, Eng, Rear, 2-63
Bracket, Mounting, Eng,Rear Lh, 2-61, 2-63
Bracket, Mounting, Filter, Fro, 3-65, 3-67
Bracket, Mounting, Gearmotor, 3-75
Bracket, Mounting, Headlamp, 2-45
Bracket, Mounting, Lever, 3-21
Bracket, Mounting, Mirror, 3-49
Bracket, Mounting, Motor, 2-137, 3-35
Bracket, Mounting, Skirt, 3-63
Bracket, Mounting, Vaporizer, 2-75
Bracket, Mounting,Alarm Switch, 2-119, 3-15, 3-16
Bracket, Mounting, 2-85, 2-131
Bracket, Mtg, Air Cleaner, 2-77, 2-79, 2-81, 2-83, 2-85, 2-87
Bracket, Mtg, Air Intake, 2-81, 2-87
Bracket, Mtg, Battery, 2-107, 2-109
Bracket, Mtg, Coil, 2-57
Bracket, Mtg, Eng, Rear, 2-63
Bracket, Mtg, Eng, Rh, 2-63
Bracket, Mtg, Engine, Rear, 2-61
Bracket, Mtg, Filter, 2-103
Bracket, Mtg, Ftg, 2-39, 2-41
Bracket, Mtg, Ign Module, 3-65, 3-67
Bracket, Mtg, Ohg, 3-17
Bracket, Mtg, Pulley, 3-31
Bracket, Mtg, Shroud, Lh, 2-105
Bracket, Mtg, Shroud, Lower, 2-101
Bracket, Mtg, Shroud, Rh, 2-105
Bracket, Mtg, Shroud, Upper, 2-101
Bracket, Mtg, Skirt, 2-35, 2-37
Bracket, Mtg, Switch, 2-47
Bracket, Mtg, Valve, 2-155
Bracket, Mtg, Vaporizer, 2-73
Bracket, Mtg, 2-83
Bracket, Oper Comp, 2-15
Bracket, Pivot, 2-137, 3-31
Bracket, Pump, Fuel, 2-93
Bracket, R. H., 2-43
Bracket, Rear, Se, 3-65, 3-67
Bracket, Rh, 2-45
Bracket, Side Brush, Valve, 3-33
Bracket, Spring, 2-137, 3-35
Bracket, Steering, Machining, 2-111
Bracket, Support, Blower, 3-19, 3-23
Bracket, Switch Contact, 2-139
Bracket, Switch, A/C, 4-45, 4-47
Bracket, Tail Pipe, 2-89
Bracket, Tailpipe, 2-89
Bracket, Wldt, Mtg A/c Comp, 3-53
Bracket, 2-7, 2-9, 2-77, 2-79, 2-97, 2-106, 3-3, 3-5, 3-7, 3-9, 3-15, 3-16, 3-25, 3-45, 3-63, 3-65, 3-67
Brake Assy, Lh, 2-113
Brake Assy, Rh, 2-113
Brake, Hand, Replmt Kit, 2-117
Brake, Hyd, Lh (Repl. by 77770), 2-113
Brake, Hyd, Rh (Repl. by 77790), 2-113
Breaker–Circuit, 2.5 Resetbl, 2-161
Breaker–Circuit, 15 Resetbl, 2-161
Breaker–Circuit, 30 Thermal, 3-53
Breather Cap and Gasket, 2-129
Breather Cap, 6-19
Breather, Hyd 40Mic NO DS, 2-3
Breather, Hyd, 2-129
Brg–Conn.Rod , 6-20
Brkt Wldt , Gas Spring, 2-19
Brkt–L,1.2 1.0 .12 .8L2/H&S, 2-57
Brush Holder, 5-21, 6-9
Brush Kit, 2-55, 2-57
Brush–Outsd Spl–50Lg – 8Dr–Poly, 2-5
Brush–Patrl Spl–50Lg – 4Qr–Nyl, 2-5
Brush–Side Swp –26 D–Assy–Fltw, 2-5
Brush–Side Swp –26 D–Assy–Nyl, 2-5
Brush–Side Swp –26 D–Assy–Poly, 2-5
Brush–Side Swp –26 D–Fltw, 2-5
Brush–Side Swp –26 D–Nyl, 2-5
Brush–Side Swp –26 D–Poly, 2-5
Brush–Sweep Spl–50Lg – 8Dr–Poly, 2-5
Brush–Sweep Spl–50Lg–24Sr–Nyl, 2-5
Brush–Sweep Spl–50Lg–8Dr–P&W, 2-5
Brush–Sweep Spl–50Lg–8Dr–Wire, 2-5
Bshg,Flange,0.62Bx0.68Od,Nylon, 3-49
Bulb, 12V .2A 32Cp #1156, 3-11, 3-13
Bulb, 12V .5A 4CP#1157, 2-7
Bulb, 12V .5A 4Cp #1157, 2-9
Bulb, 12V .9A, 3-15, 3-16

Bulb, 12V, 3-3, 3-5, 3-7, 3-9
 Bumper Assy, Se, 3-27, 3-28, 3-29
 Bumper Wldt., Rear, Gas/Die, 2-9
 Bumper Wldt., Rear, LPG, 2-9
 Bumper Wldt, Front, Rh, 2-49
 Bumper Wldt, Front, 2-47
 Bumper Wldt, Lh, 2-49
 Bumper Wldt, Rear, 2-7
 Bumper Wldt, Rh, 2-49
 Bumper Wldt, Se, Rh, Front, 3-28, 3-29
 Bumper Wldt, Sppt, Hopper, Rh, 2-49
 Bumper Wldt,Se, Lh, Front, 3-28, 3-29
 Bumper, 3/32 Matl., 3-15
 Bumper, Corner, Mach, 2-7, 2-9
 Bumper, Cover, Hopper, 2-45
 Bumper, Front, Machining, Lh, 2-47
 Bumper, Front, Machining, Rh, 2-47
 Bumper, Rubber, 2-13, 2-15, 2-25, 2-43, 2-45, 3-7, 3-9, 3-21
 Bushing En, 4-7, 4-15
 Bushing En, 4-5, 4-9, 4-13, 4-17, 4-37
 Bushing, Isolator–Inner,Rbr., 2-133, 2-135
 Bushing, Isolator, 2-51, 2-99, 2-101, 2-151, 2-153
 Bushing, Seal, 4-25, 4-26
 Bushing, 5-17

C

Cab Body, 3-43
 Cable Assy, Side Brush, Lift, 2-139, 3-31
 Cable Assy,Choke 67.00Lg, 2-65, 2-67
 Cable Assy–Batt,Pos, 48.0, 2Ga, 2-109
 Cable Assy, 3-21
 Cable Tie Mount, 3-3, 3-5, 3-7, 3-9
 Cable, Bowden, 4-45, 4-47, 4-49, 4-51
 Cable, Brake, Park, 2-117
 Cable, Lift, Main Brush, 2-145
 Cable, Push,Pull, 2-119
 Cable, Retaining, Side Brush, 2-137, 3-35
 Cable, Retaining, 2-47
 Cable, Side Brush, Lift, 2-141, 3-33
 Cable, Speed Control, 2-119
 Cabletie Mount, Adhesive, 3-11, 3-13

Cam Bushing En, 4-3, 4-11
 Cam Wldt, 2-119
 Cam, Adjuster, 2-47
 Camplate Cradle En, 4-3, 4-11
 Camplate S/A En, 4-3, 4-7, 4-11, 4-15
 Camsft.Sensor , 6-11
 Camshaft , 6-17
 Camshaft, 5-15
 Camshft Sprckt , 6-17
 Cap – Distributor, 5-23
 Cap Assembly En, 4-37
 Cap Radiator, 2-101
 Cap Screw En, 4-7, 4-15
 Cap Screw Cl, 4-25
 Cap Screw, 4-21, 4-22
 Cap, End Cl, 4-25
 Cap, End, 4-26
 Cap, Fuel, 2-93
 Cap, Gas, 2-91
 Cap, Grease Black Paint, 2-113
 Cap, Radiator 7 Psi, 2-99
 Cap, Screw, 4-26
 Cap, Valve Stem, 2-115
 Cap, 5-17
 Carb Repair Kit Ze, 2-65
 Carburetor For Lsg–423, 2-65
 Carburetor Kit, Lpg, 2-69
 Carburetor, Lpg W/Gasket, 2-69
 Cart Flow Control CP, 4-31, 4-33, 4-35
 Cart, Check Valve CP, 4-31, 4-33, 4-35
 Cart, Pilot CNTR CP, 4-31
 Cart, Pilot Cntr, 4-29
 Cart, PSI CN CP, 4-31, 4-33, 4-35
 Case Front Cover (Repl. by 21281), 4-45
 Case Front Cover, 4-49
 Chain, Link#2/0, 7Links, 2-3
 Chain,#12Jack Type 6.0Lg, 3-59, 3-61
 Chain,Jack#18,39Links,Cad15.12, 2-9
 Chain,Link#2/0,7Links, 2-7, 2-9
 Channel Wldt, Blower Wand, 3-11, 3-13, 3-16
 Channel Wldt, Fan Motor, 2-103, 2-105
 Channel Wldt, Mtg, Engine,Rear, 2-59, 2-61, 2-63

CROSS REFERENCE

- Channel Wldt, Mtg, 2-7
Channel Wldt, 2-99
Channel, Hinge, Filter Cover, 3-65, 3-67
Channel, Mounting, 2-9
Channel, Mtg, Steering Latch, 2-157
Channel, Retainer, Seal, Rear, 2-3, 2-7
Channel, Retainer, Seal,Rear, 2-9
Channel, Retainer, 2-3, 2-7, 2-9, 2-111
Channel,, 3-11, 3-13, 3-15
Charge Pmp Adap En, 4-5, 4-9, 4-13, 4-17
Check Kit, Pilot, 4-36
Check Valve, 100 Psi, 3-35
Clam Latch, 3-45
Clamp – Distributor To Block, 5-23
Clamp Wldt, Tube, Blower Wand, 3-19, 3-23
Clamp, 3.250 Id, 3-19, 3-23
Clamp, Cable 1.5 Dia, 2-137, 3-35
Clamp, Cable, 0.38D 0.38W Stl, 2-65
Clamp, Cable– Brake, 2-117
Clamp, Cable, 2-77, 2-79, 2-81, 2-83, 2-85, 2-87, 2-111
Clamp, Mtg, Motor, Upper, 2-51
Clamp, Worm Drive 3.62–5.50, 2-151
Clamp,Cable .44D .62Wide, 3-75
Clamp–Cable, 0.25Dia 0.56Wth, 2-117, 3-75
Clamp–Cable, 0.38Dia 0.38Wth, 3-59, 3-61
Clamp–Cable, 0.38Dia 0.62Wth, 2-91, 2-93
Clamp–Cable, 0.56Dia 0.38Wth, 2-53
Clamp–Cable,.69Dia. 62Wth, 2-33
Clamp–Cable, 2-31
Clamp–Muffler,For 1.87 Od Tube, 2-89
Clamp–Muffler,For 2.00 Od Tube, 2-89
Clamp–Wormdrive, 0.25– 0.62D, 2-67, 2-71, 2-77, 2-79, 2-83, 2-85, 2-91, 3-65, 3-67
Clamp–Wormdrive, 0.31– 0.88D, 2-65, 2-73
Clamp–Wormdrive, 0.56– 1.06D, 2-65, 2-67, 2-73, 2-75
Clamp–Wormdrive, 1.06– 2.00D, 2-97
Clamp–Wormdrive, 1.56– 2.50D L, 2-79, 2-81, 2-85, 2-87, 3-65, 3-67
Clamp–Wormdrive, 1.56– 2.50D, 2-77, 2-83
Clamp–Wormdrive, 1.62– 3.50D, 2-51, 2-77, 2-79, 2-81, 2-83, 2-85, 2-87, 3-19, 3-23, 3-25, 3-51, 3-65, 3-67
Clamp–Wormdrive, 1.81– 2.75D, 2-77, 2-79, 2-81, 2-83, 2-85, 2-87
Clamp–Wormdrive, 2.63– 4.50D, 2-153, 3-19
Clamp–Wormdrive, 3.62– 5.50D, 2-153
Clevis,Adjust.0.25–28Th.Cad., 2-119, 3-25
Clip Finger Grip, 3-59, 3-61
Clip Safety, 2-19
Clip, Mercury Switch, 2-47
Clip, Safety, 2-17
Closure, 3-43
Coil 12V w/Var CP, 4-35
Coil 12V CP, 4-31, 4-33
Coil 12Vdc, 4-27
Coil Ignition, 2-55
Coil, 12V W/Var, 4-28, 4-29
Collar, Clamping, 2-31
Column, Steering 12”, 2-157
Compressor R12, 3-53
Compressor, A/C, 3-53
Condensor, Air Conditioner, 3-53
Connecting Rd , 6-20
Connecting Rod Assembly, 5-19
Control Assy CI, 4-25
Control Box, Gov., 3–speed, 2-65
Control Box, Gov, 3 speed, 2-69
Control, Manual (see Breakdown), 4-3, 4-7, 4-11, 4-15
Control, Manual, 4-41
Controller Assy, Rfs, 3-75
Cooler–Hyd, 2-25
Core, Heating/Cooling, 4-45, 4-47, 4-49, 4-51
Coupler En, 4-5, 4-9, 4-13, 4-17
Coupling Assy, Flywheel, 2-59
Coupling Flywheel, 2-61, 2-63
Coupling, Hose, 2-97
Coupling,Quickdisc, Lpg, Shwd, 2-95
Coupling, 3-75
Cover – Inner – Plastic, 5-7
Cover – Intake Manifold, 5-14
Cover – Lower – Metal, 5-7
Cover – Outer – Plastic, 5-7
Cover – Upper – Metal, 5-7
Cover Access, 2-61
Cover Assy, Hopper, 2-43, 2-45

Cover Weldt. , 2-57
 Cover Wldt, Air Cond Box, 3-51
 Cover Wldt, Engine Se, 3-65, 3-67
 Cover Wldt, Engine, 2-17, 2-19, 3-19
 Cover Wldt, Fuel Inlet (Gasoline), 2-13
 Cover, A/C, 4-47, 4-51
 Cover, Access, 2-59
 Cover, Brake Kit, 2-117
 Cover, Cab, Lpg, 3-43
 Cover, Electrical, 3-75
 Cover, Housing, Electrical, 3-75
 Cover, Motor, 3-75
 Cover, Relay Panel, 2-161
 Cover, Rocker Switch Seal, 2-141, 2-159, 3-33
 Cover, 2-55, 2-57, 5-17
 Cradle Sub Assy En, 4-7, 4-15
 Cradle Wldt, Engine, Gas, 2-59
 Crankshaft Asy , 6-13
 Crnksft Seal–Rear, 6-13
 Crnksft Sprckt , 6-13
 Crnkshaft Key , 6-13
 Cyl Block Assy (Short Block Assy), 6-3
 Cylinder Assy – W/1 Piece Pan Gasket, 5-3
 Cylinder, Hyd (See Breakdowns), 2-31
 Cylinder, Hyd (See Breakdowns), 2-111
 Cylinder, Hyd , 2-39
 Cylinder, Hyd 1.5B 1.5S 2500, 2-141, 3-33
 Cylinder, Hyd 2.0B 11.6S 2500, 2-33
 Cylinder, Hyd 2.0B 8.0S 2500, 2-41
 Cylinder, Hyd 4.0B 14.5S 2500 (See Breakdowns),
 2-33
 Cylinder, Hyd 4.0B 14.5S 2500, 4-43
 Cylinder, hyd. 2.0 B 14.9S 2500, 2-33
 Cylinder, Hyd, 2-145
 Cylinder, Hydraulic, 4-42
 Cylinder, Master Brake, 2-117

D

Dampner, Engine, 2-13, 2-15
 Decal, 4-45, 4-47
 Dipstick, 2-55
 Disc, 2-51
 Disconnect, Male, 3-43
 Disk, Adjusting, 3-59
 Disk, 3-61
 Distributor – Less Cap And Rotor, 5-23
 Door Cw, 3-45
 Door Group, 3-45
 Door Wldt, Brush, Lh, 2-10
 Door Wldt, Brush, Rh, 2-11
 Door Wldt, Engine (Gasoline), 2-21
 Door Wldt, Engine (LPG), 2-21
 Door Wldt, Engine, Lpg, 2-23
 Door Wldt, Engine, 2-23
 Door Wldt, Hopper, 2-39, 2-41
 Door Wldt, Rear, 2-25
 Door, Bumper, Lpg, 2-9
 Dowel – 18.3x10.0 – Oil Pump To Block, 5-11
 Dowel – Cylinder Head to Block, 5-3
 Dowel – Flywheel Housing to Block, 5-3
 Dowel , 6-3
 Dowel Bushing En, 4-7, 4-15
 Dowel Pin En, 4-39
 Dowel Pin, 4-41
 Dowel,Frnt Cover , 6-3
 Drain Cock,.25Npt Wh#120 Angl, 2-99
 Drain Cock,.25Npt Wh#120 Angl, 2-101
 Drain Pan De, 4-45, 4-47, 4-49
 Drain Pan De, 4-51
 Drain Pan Tube De, 4-45, 4-47
 Draincock,End.Block, 2-65, 2-73, 6-3
 Drive Assy , 5-21, 6-9
 Drive Shaft, 4-18
 Drive, Valve, 4-19
 Drive, 4-19, 4-20, 4-21, 4-22, 4-25, 4-26
 Drum Assy, Brake 9/16, 2-113
 Drum, Brake, 2-113
 Dryer Bracket De, 4-45, 4-47
 Dryer, 4-45, 4-47

CROSS REFERENCE

Duct Wldt, Rfs, 3-75
Duct, Fan, Ac, 3-53
Duct, Inlet, Vac Fan, 2-35, 2-37
Duct, Rear, 2-99, 2-101
Duct, Vinyl .40X .75X26.0 .25D, 3-3, 3-5, 3-7, 3-9
Duct, Vinyl .40X.75X3.5 .25D, 3-15
Duct, Vinyl 26.0", 3-15
Duct, Wldt, 3-21
Dust Control Kit, Side Brush, 3-63

E

Elbow, 90, Rubber, 2-153
Elbow, Rubber 90 2.2Id, 2-81, 2-87
Elbow, Rubber 90 2.5 Id x 2.0 Id, 3-65, 3-67
Elbow,90 deg, 6-14
Elbow,90,Rubber 2.25Dia, 2-77, 2-79, 2-83, 2-85
Elbow,Carb,Gas, 2-65
Elbow–Rubber,90Deg,2.5I.D., 2-77, 2-83
Element Assy, 2-77, 2-79, 2-81, 2-85, 2-87
Element, Air Cleaner, 3-65, 3-67
Element, Filter Safety, 3-65, 3-67
Element, Filter, 2-105
Element, 2-83
End Cap, 4-21, 4-22
Engine Assy, Lsg423 W/Label (See Engine Breakdown), 2-55
Engine Purch Kit, 800 Lrg423Fd, 2-57
Exh.Manifold, 6-14
Expansion Block, 4-45, 4-47
Extinguisher Kit Fire 800, 3-69
Extinguisher, Fire, 3-69
Extrusion,.062 Matl10.10Lg, 2-57

F

Face Plate Ac/Heat, 4-45, 4-47
Face Plate Heat De, 4-49, 4-51
Fan, Radiator, 2-103, 2-105
Fan, Repair Kit, Reassembly, 2-153
Fender Washer, 2-10, 2-11
Ferrule, 2-51
Filter Assy, Spin–On 10Micron, 2-103
Filter Assy, Spin–on , 2-3

Filter Assy, Spin–On, 2-105
Filter Assy,Replmt Kit F/65220, 2-105
Filter Assy, 2-51
Filter Element Dn, 2-103
Filter Element, Oil, Cont. Gas SE, 2-55
Filter Element, Oil, Cont. Gas–SE, 2-3
Filter Sender Dn, 2-103
Filter, Air, A/C, 3-51
Filter, Fuel, 2-65, 2-67, 2-93
Filter, Fuelock, 2-73
Filter, Fuelockoff, Lpg, 2-75
Filter, Oil, 6-3
Filter, Pre–Cleaner, A/C, 3-51, 3-65, 3-67
Filter,Service Indicator, 2-77, 2-83
Fitting – Vacuum, 5-14
Fitting, Barbed, 2-91
Fitting, Brass Em06/Pm02, 2-79, 2-85, 3-65, 3-67
Fitting, Special, Carb, 2-71
Fitting–Brs Str, 2-93
Flange, Mounting, 4-20, 4-21, 4-22
Flange,Brg,3 Hole, 2-143
Flasher,12V.Ideal Co.Hd552Ps83, 3-15, 3-16
Flat Washer, 3/8" Hard, 3-33
Fluid, Hyd Oil, SHP 15/40 5Gal, 2-3
Flywheel Assy, Rework, 2-59, 2-61
Flywheel, 6-15
Foam Case Insul De, 4-45, 4-47, 4-49, 4-51
Foam, Door, 3-45
Foam, Front Sill, 3-47
Foam, Insulation, 3-17
Foam, Lh Front Pos, 3-47
Foam, Lh Rear Pos, 3-47
Foam, Lh Side Sill, 3-47
Foam, Rear Sill, 3-47
Foam, Rh Front Pos, 3-47
Foam, Rh Rear Pos, 3-47
Foam, Rh Upper Sill, 3-47
Follower, Piston, 4-7, 4-15
Follower,Piston En, 4-3, 4-11
Frame Assy–Door, 3-45
Frame Asy–Cab, 3-43
Frame Wldt , 2-7

Frame&Mag.As , 5-21, 6-9
 Frame, 2-9
 Frnt Glass Asy–Cab, 3-43
 Frnt Glass Asy–Door, 3-45
 Ftg Cap Npt 02Pf, 3-65, 3-67
 Ftg, Breather, 2-53, 3-75
 Ftg, EI90 Npt/02Pf–02Pm, 2-67
 Ftg, Grease .12Nptf–Str, 2-147
 Ftg, Grease.12 Npt 45 .88L, 2-149
 Ftg, Grease.25–28Th 90 .75L, 2-111
 Ftg,Brass Tee 04Pf– 04Pm– 04Pf, 2-73, 2-75
 Ftg,Brass,St Bm03/Pm02, 2-75, 3-75
 Ftg,Brass,Tee 06lf– 02Pm– 06lf, 2-117
 Ftg,Bulkhead .25Npt Wh W21204, 2-95
 Ftg,Bulkhead–Barb Wh 1074X4, 2-53, 3-75
 Ftg,Plstc,Tee,Barb.38–.62–.62, 2-65, 2-73
 Ftg–Brs E90 Bm05/Pm02, 2-71
 Ftg–Brs E90 Bm10/Pm06, 2-75
 Ftg–Brs E90 Em10/Pm06, 2-73
 Ftg–Brs lf05/lf05, 2-93
 Ftg–Brs Str Bm03/Pm02, 2-53, 2-73
 Ftg–Brs Str Bm06/Pm06, 2-65, 2-73
 Ftg–Brs Str Em06/Pm02, 2-77, 2-83
 Ftg–Brs Str lf05/Pm02, 2-93
 Ftg–EI90 Npt/Npt 02Pf–02Pm, 2-65
 Ftg–EI90 Npt/Npt 04Pf/04Pm, 2-95
 Ftg–Hyd Cap Jf08, 2-61
 Ftg–Hyd E45 Jm04/Om04, 2-111, 2-145
 Ftg–Hyd E45 Jm08/Om08, 2-155
 Ftg–Hyd E45 Jm20/Jf20, 2-121
 Ftg–Hyd E45 Pm04/Pf04, 2-95
 Ftg–Hyd E90 Jm04/Om04, 2-141
 Ftg–Hyd E90 Jm04/Jf04, 2-31, 2-33, 2-39, 2-41, 2-129, 2-133
 Ftg–Hyd E90 Jm04/Om04, 2-39, 2-41, 2-131, 2-141, 2-145, 2-155, 3-33
 Ftg–Hyd E90 Jm04/Om06, 2-31, 2-33, 2-133, 2-135
 Ftg–Hyd E90 Jm06/Jf06, 2-135
 Ftg–Hyd E90 Jm06/Om06, 2-111, 3-33
 Ftg–Hyd E90 Jm06/Om08, 2-31, 2-33, 2-103, 2-105, 2-133
 Ftg–Hyd E90 Jm08/Jf08, 2-131, 2-133, 2-135, 3-35
 Ftg–Hyd E90 Jm08/Jm08, 2-61
 Ftg–Hyd E90 Jm08/Om08, 2-131, 2-133, 3-35
 Ftg–Hyd E90 Jm08/Om10, 2-155
 Ftg–Hyd E90 Jm10/Jf10, 2-73
 Ftg–Hyd E90 Jm12/Jf12, 2-129
 Ftg–Hyd E90 Jm12/Om12, 2-103, 2-105, 2-121
 Ftg–Hyd E90 Jm12/Om16, 2-121
 Ftg–Hyd E90 Jm20/Jf20, 2-121
 Ftg–Hyd E90 Pm06/Jm10, 2-71
 Ftg–Hyd E90 Pm08/Jm10, 2-69, 2-73, 2-75
 Ftg–Hyd E90 Special Jm12/Jf12, 2-129
 Ftg–Hyd E90, 2-129, 2-141
 Ftg–Hyd Plg Om06, 2-31, 3-33
 Ftg–Hyd Plg Om12, 2-129
 Ftg–Hyd Rst JM04/.047, 2-135
 Ftg–Hyd Rst Jm04/.063, 2-31, 2-33
 Ftg–Hyd Str Jm12/Om16, 2-121
 Ftg–Hyd Str Jm04/Jf06, 2-133
 Ftg–Hyd Str Jm04/Om04, 2-143
 Ftg–Hyd Str Jm04/Om06, 2-133, 2-135
 Ftg–Hyd Str Jm04/Om08, 2-31, 2-33
 Ftg–Hyd Str Jm06/Jf08, 3-35
 Ftg–Hyd Str Jm06/Om06, 2-131, 2-133, 2-157, 3-33, 3-35
 Ftg–Hyd Str Jm06/Om08, 2-103, 2-105, 2-135
 Ftg–Hyd Str Jm06/Om10, 2-121, 2-137
 Ftg–Hyd Str Jm06Om06L, 2-131
 Ftg–Hyd Str Jm08/Jm06, 2-137, 2-155
 Ftg–Hyd Str Jm08/Jm08, 2-155
 Ftg–Hyd Str Jm08/Om08, 2-131, 2-135, 2-143
 Ftg–Hyd Str Jm08/Om10, 2-121, 2-155
 Ftg–Hyd Str Jm08Om08L, 2-131
 Ftg–Hyd Str Jm12/Om12, 2-25, 2-129
 Ftg–Hyd Str Jm12/Om16, 2-111
 Ftg–Hyd Str Jm12Om12L, 2-131
 Ftg–Hyd Str Jm20/Om20, 2-121, 2-129
 Ftg–Hyd Str Mom14/Jm08, 2-61
 Ftg–Hyd Str Om/Of, 2-129
 Ftg–Hyd Str Om08/Of06, 3-35
 Ftg–Hyd Str Pm04/Jm06, 2-73, 2-75
 Ftg–Hyd Str Pm04/Pf02, 2-55, 2-57, 2-73, 2-75
 Ftg–Hyd Str Pm06/Pf04, 2-65, 2-73
 Ftg–Hyd str, 2-141
 Ftg–Hyd StrJm06/Om10, 3-35

CROSS REFERENCE

Ftg-Hyd Tee Jm04Jfjm, 2-133, 2-135
Ftg-Hyd Tee Jm04Jmjf, 2-133, 2-135
Ftg-Hyd Tee Jm04Jmjm, 2-39, 2-41
Ftg-Hyd Tee Jm04Jmom, 2-129
Ftg-Hyd Tee Jm04Omjm, 2-103, 2-105
Ftg-Hyd Tee Jm06JmJf, 2-133
Ftg-Hyd Tee Jm06Jmjf, 2-129, 2-135
Ftg-Hyd Tee Jm06Jmom, 2-129
Ftg-Hyd Tee Jm06Omjm, 3-35
Ftg-Hyd Tee Jm08Jmjf, 2-131, 3-35
Ftg-Hyd Tee Jm08OmJm, 2-133
Ftg-Hyd Tee Jm08Omjm, 2-135
Ftg-Hyd Tee Jm12Jfjm, 2-121
Ftg-Hyd Tee Jm12Jmjf, 2-129
Ftg-Plug NPT 04Pm Hx Soc, 2-73
Ftg-Plug Npt 04Pm Hx Soc, 2-65
Ftg-Str Npt/Npt S04Pf-04Pm, 2-95
Ftg-Tee Npt 04Pm- 04Pf- 04Pf, 2-95
Fuelline, .312 Od, 2-93
Fuelline, .375 Od, 2-75
Fuelline,.375 Od, 2-73
Fuelock Replacement Kit, 2-75

G

Gas Cap, Protectoseal, 3-68
Gasket – Carburetor, 2-69
Gasket – Cylinder Head, 5-6
Gasket – Drain Plug, 5-5, 5-11
Gasket – Front Cover, 5-5, 5-7
Gasket – Intake Manifold Cover, 5-5, 5-14
Gasket – Intake Manifold, 5-5, 5-14
Gasket – Oil Pan – One Piece, 5-5, 5-11
Gasket – Oil Pump To Pick Up, 5-11
Gasket – Outer, 5-5, 5-7
Gasket – Rocker Arm Cover, 5-17
Gasket – Water Outlet, 5-22
Gasket – Water Pump, 5-5, 5-22
Gasket Kit, Lower, 5-5
Gasket Kit, Valve Grind, 5-5
Gasket Oil, 6-5, 6-11
Gasket Water Outlet Connection, 6-21
Gasket, 2.7D 1.5B.12T 5/ 2.1Bc, 2-91, 2-93

Gasket, Air Cond Box, 3-51
Gasket, Carb To Engine, 2-67, 2-71
Gasket, Carburetor Air Horn, 2-65, 2-67
Gasket, Carburetor, 2-65, 2-67, 2-69, 2-71
Gasket, Cover, Alum, 3-75
Gasket, Duct, 2-151
Gasket, Exh. Flange, 6-14
Gasket, Fire Switch, 2-155
Gasket, Fuel Pump 2.3L Ford, 2-65
Gasket, Head, 6-5, 6-6
Gasket, Hyd Cap, 2-129
Gasket, Hyd Tank Breather, 2-129
Gasket, Push On, 3-43
Gasket, Vac Fan, 2-153
Gasket,Oil Pan , 6-5, 6-11
Gasket,Rocker Cover , 6-19
Gasket, 5-5
Gauge, Sight Lh, 2-129
Gear – Driven, 5-23
Gear Assy , 5-21, 6-9
Geroter,Ring In En, 4-5, 4-9, 4-13, 4-17
Geroter,Ring Ot En, 4-5, 4-9, 4-13, 4-17
Gerotor Set Cl, 4-25, 4-26
Gerotor Set, 4-19, 4-20, 4-21, 4-22
Glass, Rear, 3-43
Glass, Sliding, Lh, 3-43
Glass, Windshield, 3-43
Governor Assy, Gas, 2-67
Governor Assy, Lpg 2.3, 2-71
Grip Vinyl .18 X .75 X 4.00, 3-21, 3-25
Grip, Handle, Flat, 3-59, 3-61
Grommet Rbr 0.25ld For .09Matl, 3-16, 3-41
Grommet, 3.00 ld, 2-83
Grommet, 3.00ld, 2-85, 2-87
Grommet, Flexible .25, 2-9
Grommet, Rbr, .50 ID, For .25 Matl, 2-7
Grommet,Rbr,0.25ld,For .09Matl, 2-159
Grommet,Rbr,0.38ld,For .06Matl, 3-3, 3-5, 3-7, 3-9
Grommet,Rbr,0.38ld,For .19Matl, 3-11, 3-13
Grommet,Rbr,0.50ld,For .25Matl, 2-9
Grommet,Rbr,0.56ld,For .13Matl, 3-15, 3-16
Grommet,Rbr,0.62ld,For .06Matl, 2-53, 3-75

Grommet,Rbr,0.63ld,For .13Matl, 3-3, 3-5
 Grommet, 3-43
 Gskt Kit,Lower, 6-5
 Gskt Kit,Upper , 6-5
 Gskt,Exh.Mnflid, 6-14
 Gskt,Frnt Cvr , 6-5
 Gskt,Front Cvr , 6-7
 Gskt,In.Manfld , 6-5
 Gskt,Int.Mnflid, 6-14
 Gskt,Oilpmp/Blk , 6-11
 Gskt,Pmp/Putube, 6-5
 Gskt,Pu Tube , 6-11
 Gskt,Rockr Cvr , 6-5
 Gskt,Water Pump, 6-5, 6-21
 Gskt-Waterout , 6-5
 Guard Kit, Overhead, 3-17
 Guard Replmt Kit Side Brush Lh, 3-35
 Guard Wldt., 2-55
 Guard Wldt, Hopper, 2-49
 Guard Wldt, Lights, Revl & Flsh, 3-3, 3-5, 3-7, 3-9
 Guard Wldt, Lights, Revl&Flsh, 3-11, 3-13
 Guard Wldt, Overhead, 3-17
 Guard Wldt, Side Brush, 2-137
 Guard Wldt, Sidebrush, 3-35
 Guard Wldt, 3-57
 Guard, Mirror, 3-49
 Guard, Side Brush Repl Kit Rh, 2-137
 Guard, Side Brush, 2-137, 3-35
 Guard, 2-57
 Guide – Timing Belt, 5-13, 5-15
 Guide, 2-51

H

Handle Wldt, Center, 2-133
 Handle Wldt, Latch, 2-17
 Handle Wldt, Lh, 2-133
 Handle Wldt, Rh, 2-133
 Handle Wldt, Side Brush Lift, 3-31
 Handle, Center, 2-135
 Handle, Grab, 3-19, 3-23
 Handle, Lh, 2-135
 Handle, Lift, Brush, 2-157

Handle, Rh, 2-135
 Handle, 2-139, 3-59, 3-61
 Harness, Rfs Jumper, 3-75
 Harness, Air Conditioner, 3-53
 Harness, Alarm, Backup, 3-15, 3-16
 Harness, Hopper 800/810, 2-183
 Harness, Hopper, Rfs, 3-75
 Harness, Hopper, 2-176
 Harness, Jumper, Backup, 3-15
 Harness, Main, Gas/LPG, Lrg, 2-183
 Harness, Main, Gas/LPG, Lsg, 2-176
 Harness, Motor, Duct, 3-75
 Harness, Neutral, Start, 3-73
 Harness, Rev/Flash Light,Cab O, 3-11, 3-13
 Harness, Side Brush, L.H., 3-36, 3-37
 Harness, Tank, Fuel, 2-91
 Harness, Turn/Rotate/Tail Lights, 2-176, 2-183
 Harness, Wire, 3-43
 Harness,Rev/Flsh Light,Cab,Ohg, 3-3, 3-5, 3-7, 3-9
 Head , 5-6
 Head-W/O Valves, 6-6
 Head-W/Vlvs&Cam, 6-6
 Headlight Assy,210G, 3-15, 3-16
 Headlight, 12V.Rect., 2-43, 2-45
 Headliner, Front, 3-47
 Headliner, Rear Cw, 3-47
 Heater Hose 72In De, 4-45, 4-47, 4-49, 4-51
 Heater, Pressurizer (Repl. by 21271), 4-49
 Heater, Pressurizer Group (See Breakdowns), 3-55
 Heater, Pressurizer Grp (Repl. By 21271) (See Breakdowns), 3-55
 Heater, Pressurizer, 4-51
 Heater/Pressurizer Assy, 3-55
 Hinge Wldt, W/Pin, 2-21
 Hinge Wldt, 2-21, 2-43
 Hinge, W/Pin, 2-23
 Hinge, 2-17, 2-19, 2-23, 2-45
 Hook, S-.120 X 1.31, Zinc Pl., 2-9
 Hook, 2-103
 Hopper Floor Kit, St Stl 800, 3-26
 Hopper Wldt , 2-35
 Hopper Wldt, 2-37
 Horn, 12V, 2-17, 2-19

CROSS REFERENCE

Horn, Back-Up Alarm, 3-15, 3-16
Hose , 6-3
Hose Clamp De, 4-45, 4-47, 4-49, 4-51
Hose Elbow 5/8 De, 4-45, 4-47, 4-49, 4-51
Hose Lpg, 10Lpg 28In.Lg, 2-73, 2-75
Hose Vac.,Rubber, .16ld,21.0L, 2-73
Hose, .62 Id X 38. Lng Heater, 2-67
Hose, .62ld X 20.0 Lng Heater, 2-75
Hose, A/C #10, 3-53
Hose, A/C #8 134A, 3-53
Hose, A/C Drain, 4-45, 4-47
Hose, Fan Inlet, 2-151, 2-153
Hose, Fuelline, 10.0L, 2-93
Hose, Lpg, 4Lpg X 35.0Lg, 2-95
Hose, Lpg, 4Lpg X 40.0Lg, 2-95
Hose, Molded, Air Intake, 2-79, 2-81, 2-85, 2-87
Hose, Molded, Se, Gas (Cut in half), 3-67
Hose, Molded, Se, Gas, 3-65, 3-67
Hose, Pcv, 2-55
Hose, Radiator, Lower, 2-97
Hose, Radiator, Upper, 2-97
Hose, Rbr .312 Id X 6.0 Lg, 2-91
Hose, Rbr .38ldx .620D 35.0Lg, 2-65, 2-73
Hose, Rbr .38ldx .620d 21.0Lg, 2-77, 2-83
Hose, Rbr .62 Id X 11.5 Lg, 2-65
Hose, Rbr .62 Id X 2.0 Lg, 2-65, 2-73
Hose, Reducer, 3-19
Hose, Rubber.38ldx.620d 21.0Lg, 2-67, 2-71, 2-79, 2-85
Hose, Rubber, Elbow, 3.00, 3-23
Hose, Rubber, Elbow, 3-51
Hose, Rubber, 3-19, 3-23
Hose, Vac, Rubber, 2-53
Hose, Vacuum .16 Id X 15.0 Lg, 2-55
Hose, Vacuum, .16 Id X 76.0 Lg, 3-75
Hose, Vacuum,.16ld X 15.0 Lg, 2-57
Hose, Vacuum,.16ld X 21.0Lg, 2-75
Hose,.62ld X 24.0 Lng Heater, 2-73
Hose,.62ld X 31.0 Lng Heater, 2-73
Hose,Heater .62ldx53.0Lg, 2-67, 2-75
Hose& Cuff Assy,Vinyl3.0ldx 24, 3-19, 3-23
Hose& Cuff Assy, 3-23
Hose&2Cuff Assy,Vinyl2.0ld10Ft, 3-59, 3-61
Hose-Hyd Ar 04 , 2-127
Hose-Hyd Ar 04, 2-127
Hose-Hyd Ar04, 2-127
Hose-Hyd Low 04 Jf/J9, 2-125
Hose-Hyd Low 04, 2-127
Hose-Hyd Low04 Jf/J9, 2-125, 2-127
Hose-Hyd Low06 Jf/J9, 2-125
Hose-Hyd Low06, 2-127
Hose-Hyd Low12 Jf/Jf, 2-125, 2-127
Hose-Hyd Low12, 2-127
Hose-Hyd Med 04, 3-39
Hose-Hyd Med 06, 3-39
Hose-Hyd Med04 Jf/J4, 2-125, 2-127
Hose-Hyd Med04 Jf/J9, 2-125
Hose-Hyd Med04 Jf/Jf, 2-125, 2-127
Hose-Hyd Med04 Jf/JI9, 2-125
Hose-Hyd Med04, 2-127
Hose-hyd Med04, 2-127
Hose-Hyd Med06 Jf/J4, 2-125
Hose-Hyd Med06 Jf/J9, 2-125, 2-127, 3-38
Hose-Hyd Med06 Jf/Jf, 2-125, 2-127
Hose-Hyd Med06, 2-127
Hose-Hyd Med08 Jf/J4, 2-125, 2-127
Hose-Hyd Med08 Jf/J9, 2-125, 2-127
Hose-Hyd Med08 Jf/Jf, 2-125
Hose-Hyd Med08, 2-127
Hose-Hyd Med12 Jf/J4, 2-125
Hose-Hyd Med12, 2-127
Hose-Hyd Med78 Jf/J9, 2-127
Hose-Hyd Replm Kit 800/810, 2-125
Hose-Hyd Replmt Kit 800/810, 2-125
Hose-Hyd Suc20 Jf/J4, 2-125
Hose-Hyd Suc20 Spcl 22.5, 2-127
Hose-Hyd, 2-61, 2-127
Housing Assy, Rear Hub, 2-111
Housing Assy, 4-19
Housing En, 4-7, 4-15
Housing S/A En, 4-3, 4-7, 4-11, 4-15
Housing Wldt, Vac Fan, Front, 2-151, 2-153, 3-21
Housing Wldt, Vac Fan, Rear, 2-151, 2-153
Housing, Brg, 4-19
Housing, Flywheel, Machined, 2-59, 2-61, 2-63

Housing, Sppt, Wheel, 2-111
 Housing,Control En, 4-39
 Housing,Control, 4-41
 Housing, 4-21, 4-22
 Hsg W/Brg , 5-21, 6-9
 Hub and Stud Assy., 2-111
 Hub Assy, 2-115

I

Ignition Coil , 6-22
 Ignition Module , 6-22
 Impeller 9.5 Dia. 18 Blade Mac, 2-151, 2-153
 Indicator Service Air Filter, 2-79, 2-81, 2-85, 2-87, 3-65, 3-67
 Indicator,Oil , 6-3
 Indicator,Service,Air Filter, 2-77, 2-83
 Inner Cover , 6-7
 Insert–Oilfilt , 6-3
 Instr. Valve Repair Info, 4-37
 Insulation, Acoustic, A Clnr, 2-83
 Insulation, Acoustic, Air Clnr, 2-85, 2-87
 Insulation, Acoustic, Fan, 2-151, 2-153, 3-21
 Insulation, Acoustic, Vac Fan, 2-151, 2-155
 Insulation, Acoustic,Vac Fan, 2-151
 Insulation, S/Foam 1.0X3.0X3.0, 2-9
 Insulation, S/Foam 1.5X4.0X4.0, 2-9
 Insulation, S/Foam, Seat, 2-15
 Insulation, S/Foam, 2-9, 2-17, 2-19, 2-23, 3-25
 Insulation,S/Foam .8X19.3X20.3, 3-65, 3-67
 Insulation,S/Foam1.0X 3.0X 3.0, 2-7
 Insulation,S/Foam1.5X 4.0X 4.0, 2-7
 Int.Manifold, 6-14
 Isolator, Exhaust, 2-89
 Isolator, Mounting, 2-63
 Isolator, Mtg, 2-59, 2-61, 2-63
 Isolator, Vac Fan, 2-131
 Isolator, Vibration, 2-155
 Isolator–Vibration .25–20, 2-89
 Isolator–Vibration .31–18, 2-25
 Isolator–Vibration,60 Lb.Ratng, 2-155
 Isolator, 2-59, 2-61

J

Jamb Nut 7/16 Hex De, 4-45, 4-47, 4-49, 4-51

K

Key – Sprocket To Crankshaft, 5-13
 Key En, 4-5, 4-9, 4-13, 4-17
 Key Set,Switch Ku, 2-159
 Key Set, 3-45
 Key, Square 0.12 0.12 00.50 LG, 4-24
 Key, Woodruff, 4-20
 Key, 4-19, 4-23, 5-17
 Kit–Attaching , 5-21, 6-9
 Knob, Adjusting, 2-139, 3-31
 Knob, Fan, 4-45, 4-47, 4-49, 4-51
 Knob, Handle, Threaded, 2-139, 3-31
 Knob, Plastic, 2-141, 2-147, 2-149
 Knob, Temp, 4-45, 4-47
 Knob,0.38–16,1.25Dia,Plastic, 3-61
 Knob, 2-133, 2-135

L

Label Set, Info & Hazard, 2-184
 Label Set, Operational 800, 2-184
 Label, Numerals 800, 2-184
 Label, Vac Wand, 3-59, 3-61
 Lanyard Assy., 2-25
 Latch Assy, Lpg Tank Mtg,W/Nut, 2-95
 Latch, Bolt, 2-21, 2-23, 3-65, 3-67
 Latch, Bumper, 2-47, 2-49
 Latch, Door, 3-72
 Latch, Hook (Supplier's Lh), 2-11
 Latch, Hook (Supplier'S Rh), 2-10, 2-21
 Latch, Hook Rh, 2-23
 Latch, Hook, Lh, 3-65, 3-67
 Latch, Hook, Rh, Single Catch, 2-45
 Latch, Hook, Rh, 2-43
 Latch, Rear Wind, 3-43
 Latch, 2-17, 2-19, 2-25, 2-143
 Leg Wldt, Bumper, Se, 3-27, 3-28, 3-29
 Lens,Flashing Lite Fr207 Amber, 3-3, 3-7, 3-11
 Lens,Flashing Lite Fr207 Blue, 3-3, 3-7, 3-11
 Lens,Flashing Lite Fr207 Red, 3-3, 3-7, 3-11

CROSS REFERENCE

Lens,Rev.Light,Amber, 3-5, 3-9, 3-13
Lens,Rev.Light,Blue, 3-5, 3-9, 3-13
Lens,Rev.Light,Red, 3-5, 3-9, 3-13
Lever , 5-21, 6-9
Lever Carburator, 3-25
Lever Wldt, 2-139, 3-31
Lever, Blower, 3-21
Lever, Brake, 2-117
Lever, Carburetor, 2-65
Lever, Governor Actuator, 2-65, 2-69
Lever, Handle, Latch, 2-19
Lever, 2-139, 3-25, 3-31
Lifting Eye, 6-14
Light Assy Stop/Red 12V- . A, 2-9
Light Assy Stop/Red 12V- A, 2-7
Light Kit Flashing, 3-11
Light Kit Flsh 800L Cab, 3-7
Light Kit Flsh 800L Ohg, 3-3
Light Kit Revl 800 Low, 3-13
Light Kit Revl 800L Cab, 3-9
Light Kit Revl 800L Ohg, 3-5
Light Kit, Side Brush, 3-41
Light, Dome 12V, 3-43
Light, Flashing, Amber, 12V-Re, 3-3, 3-7, 3-11
Light, Spot Hi-D 255li L, 3-41
Light,Rev.Amber 12V-Reworked, 3-5, 3-9
Light,Rev.Amber 12V, 3-13
Link, Connecting, 3-45
Link, Eccentric, 2-51
Link, Feedback En, 4-39
Link, Feedback, 4-41
Link, Pivot, Machined, 2-27
Link, Pivot, 2-29
Link, Tension 5.2 Lg, 3-53
Link, Tension, 3-53
Lintel Wldt, Main, 2-17
Lintel Wldt, Rear, 2-17
Lintel, Main, 2-19
Lintel, Rear, 2-19
Locknut, 6-21
Lockwasher En, 4-3, 4-7, 4-11, 4-15
Louver, Recirc, 4-47, 4-51

Louver, 4-45, 4-47, 4-49, 4-51
Lower Cover , 6-7

M

Magnet, Drive Brush, 2-45
Magnet, 2-39
Main Bearing – 0.002 U/S, 5-13
Main Bearing – 0.010 U/S, 5-13
Main Bearing – 0.020 U/S, 5-13
Main Bearing – 0.030 U/S, 5-13
Main Bearing – Standard Blue, 5-13
Main Bearing – Standard Red, 5-13
Main Brg,.002 Lower, 6-13
Main Brg,.002 Upper, 6-13
Main Brg,.010 Lower, 6-13
Main Brg,.010 Upper, 6-13
Main Brg,.020 Lower, 6-13
Main Brg,.020 Upper, 6-13
Main Brg,.030 Lower, 6-13
Main Brg,.030 Upper, 6-13
Main Brg,Stdblu, 6-13
Main Brg,Stdred , 6-13
Main Brg,Stdred, 6-13
Maintenance Kit, 400HR 800/810 gas/lpg, 2-3
Maintenance Kit, 800HR 800/810, 2-3
Maintenance Kit, Skirts 800, 2-3
Maintenance Kit, Skirts, 2-3
Manifold, Exhaust, 5-14
Manifold, Intake, 5-14
Manual Op/Mt 800 French, 3-76
Manual Op/Mt 800 Spanish, 3-76
Manual Control En, 4-39
Manual Pkg 800, 3-76
Manual, Service 800/810, 3-76
Manual-Fiche Pkg 800, 3-76
Mirror Kit, Side Brush, 3-49
Mirror, Side Brush, 3-49
Mirror,8.0 Round,Convex, 3-49
Module, Ignition, 2-55
Molding, Trim 11-14Ga 3.00, 3-11, 3-13, 3-15, 3-16
Molding, Trim 11-14Ga 4.0, 2-117
Molding, Trim 11-14Ga 15.75, 2-13, 2-15

Molding, Trim 11–14Ga 5.00, 2-13
 Molding, Trim 11–14Ga 5.75, 2-15
 Molding, Trim 16Ga&Thinnr 10.0, 2-15
 Molding, Trim 3/16–5/16 2.75, 2-139
 Molding, Trim 3/16–5/16 5.0, 2-63
 Motor, Ele, Geared, 12Vdc, 3-75
 Motor, Electric, 13.6 Vdc, 2-51
 Motor, Hyd (Repl. By 79781) (See Breakdowns), 3-35
 Motor, Hyd Gear In 17.9 B 1500 (See Breakdowns), 3-35
 Motor, Hyd, (Repl. by 79781) (See Breakdowns), 2-137
 Motor, Hyd, (See Breakdowns), 2-137
 Motor, Hydraulic (Repl. by 79781), 4-21
 Motor, Hydraulic, 4-20, 4-22, 4-23, 4-24
 Motor, Propelling, 4-19
 Motor, Starting, Perm Mag, 12V (See Engine Breakdown), 2-59, 2-61
 Motor, Starting, Perm Mag, 12V, 5-21, 6-9
 Motor, Wiper 12V, 3-43
 Motor–Hyd Gear Ex (See Breakdowns), 2-155
 Motor–Hyd Gear In (See Breakdowns), 2-111
 Motor–Hyd Gear In (See Breakdowns), 2-143
 Motor–Hyd Gear In 10.0 (See Breakdowns), 2-103
 Motor–Hyd, Gear In 10.0 (See Breakdowns), 2-105
 Muffler, Exhaust, 2-89

N

Nut – M10, 5-11
 Nut – M9, 5-19
 Nut En, 4-3, 4-7, 4-11, 4-15
 Nut Low Crown .62–18, 2-141
 Nut M8–1.25, 6-14
 Nut, Adjustable, Lpg Tank Mtg, 2-95
 Nut, Cart., LNG CP, 4-31, 4-33, 4-35
 Nut, Cart., LNG., 4-28
 Nut, Cart., SHT CP, 4-31, 4-33, 4-35
 Nut, Cart., Sht, 4-29
 Nut, Conrod–8, 6-20
 Nut, Jam, 4-3, 4-7, 4-11, 4-15
 Nut, M6 , 6-7
 Nut, Slotted Hex, 4-20
 Nut, Wheel Lug, 9/16–18, 2-113

Nut, Wheel Lug, 2-111
 Nut, Wing, Air Horn, 2-65
 Nut,Lock–Special 2.16–18Uns, 2-111
 Nut,M10 , 6-11
 Nut,Wing .44–20 Special, 3-65, 3-67
 Nut&Washer,M8 , 5-21, 6-9
 Nut–Hxslot 1.00–20 Pltd, 2-113
 Nut–Low Crown .31–18 Pltd, 3-55
 Nut–Low Crown .31–18 Pltd, 3-53
 Nut–Low Crown .50–20 Pltd, 2-151
 Nut–Low Crown .50–20 Pltd, 2-153
 Nut–Wheel .50–20, 2-113
 Nut, 4-19

O

O–Ring #6, 3-53
 O–Ring Gland, 2-121
 O–Ring Seal – Distributor To Block, 5-23
 O–Ring, #8, 3-53
 O–Ring, Water Pump Adaptor, 6-21
 O–Ring,2.375 , 6-11
 O–Ring–2.250 , 6-11
 O–Ring, 3-53
 Oil Pan Assy , 6-11
 Oil Pan Spacer , 6-11
 Oil Pickup Tube , 6-11
 Oil Plug, 6-11
 Oil Pmp Sprkt , 6-11
 Oil Pump , 6-11
 Oil Seal, Front, 6-5, 6-13, 6-17
 Oper/Video Vhs, 800, 3-76
 Orifice, Valve En, 4-3, 4-7, 4-11, 4-15
 Outer Cover , 6-7
 Output Shaft Assembly, 4-20

CROSS REFERENCE

P

Pad, Rubber, 3-19, 3-23
Pad, Tread, 2-119
Pad, 2-77, 2-79, 2-81, 2-83, 2-85, 2-87, 2-117, 3-25
Paddle Handle, 3-45
Pan Assembly – Oil – 1 Piece Pan Gasket, 5-11
Panel Wldt W/Label, 2-15
Panel Wldt, Cover, 3-65, 3-67
Panel Wldt, Duct, Vac Fan, 2-151
Panel Wldt, Fender, Lh, 2-43, 2-45
Panel Wldt, Fender, Rh, 2-43, 2-45
Panel Wldt, Headlight, 2-43
Panel Wldt, Hopper, Floor, LH, 3-26
Panel Wldt, Hopper, Floor, RH, 3-26
Panel Wldt, Oper Comp, 2-13
Panel Wldt, Rear, Lh, 2-9
Panel Wldt, Rear, Rh, 2-9
Panel Wldt, Shaker, 2-51
Panel Wldt, Support, Seat, 2-13
Panel Wldt, Transition, Fan, 2-103
Panel Wldt, 2-35
Panel, Access, 2-119
Panel, Air Conditioning, 2-13, 2-15
Panel, Bottom, Hopper, Rh, 2-37
Panel, Cover, A/C Filter, 3-65, 3-67
Panel, Cover, Access, 2-13, 2-15
Panel, Cover, Dash, 2-159
Panel, Cover, Front A/C, 3-65, 3-67
Panel, Cover, Rear, A/C Filter, 3-65, 3-67
Panel, Cover, 3-59, 3-61
Panel, Deflector, Dirt, Lh, 2-35, 2-37
Panel, Deflector, Dirt, Rh, 2-35, 2-37
Panel, Flap Valve, 3-25
Panel, Fuel Inlet (Gasoline), 2-13
Panel, Fuel Inlet (LPG), 2-13
Panel, Fuel Inlet, 2-15
Panel, Fuel, Inlet, Lpg, 2-15
Panel, Headlight, 2-45
Panel, Hopper Door, 2-39
Panel, Hopper, Bottom, Lh, 2-37
Panel, Lintel, 3-23
Panel, Permafilter, Upper, 2-35, 2-37
Panel, Support, Seat, 2-15
Panel, Transition, Fan, 2-105
Panel, Vac Duct, 3-25
Panel, 2-23, 3-3, 3-5, 3-7, 3-9
Pcv Vlv Asy , 6-3
Pedal Wldt, Lower, 2-119
Pedal Wldt, 2-117
Pedal, Upper, 2-119
Pin – 1/8 x 3/4, 5-23
Pin – Armature, 5-23
Pin Assy, .312X3.0 W/Lanyard, 2-137, 3-35
Pin Assy, Spring, 3-45
Pin Hair Cotter .056Dx1.1L, 3-25
Pin Weldt., 2-29
Pin Wldt., 2-33
Pin Wldt, 1.250 Od X 4.50, 2-27, 2-31
Pin Wldt, 1.500 Odx 5.00, 2-27
Pin Wldt, Latch, 2-43, 2-45
Pin, 1.00 Odx 4.50, Drilled, 2-31, 2-33
Pin, 1.25 Odx 3.50, Grooved, 2-31, 2-33
Pin, 1.25 Odx 5.00, Drilled, 2-27
Pin, 1.250 Od X 4.50, 2-29, 2-33
Pin, 1.500 ODx7.81, Drilled, 2-29
Pin, 1.500 Odx 5.00, 2-29
Pin, 1.500 Odx6.50, Drilled, 2-27
Pin, 1/4X.32 , 6-17
Pin, Clevis .18 Dia.X .62 Lg, 2-135
Pin, Clevis .25 Dia, 1.000 Lg., 2-119
Pin, Clevis .31 Dia X 4.50 Lg, 2-119
Pin, Clevis .375D X 1.000 Lg, 2-117
Pin, Clevis .375D X 1.312 Lg, 2-119
Pin, Clevis .50 Dia X 2.25 Lg, 2-39, 2-41
Pin, Clevis .50 Dia X 4.50 Lg, 2-119
Pin, Cntrl Assy En, 4-39
Pin, Cotter .094X1.00, 2-141
Pin, Headed En, 4-39
Pin, Headed, 4-41
Pin, Hitch .50D X 1.50L, 2-9
Pin, Spring Cl, 4-25
Pin,Clevis,0.25 Dia.X 0.75 Lg, 2-119, 2-133, 3-25
Pin,Clevis,0.31 Dia X 1.00 Lg, 2-139, 3-31
Pin,Clevis,0.37 Dia.X 2.12 Lg, 2-141, 3-33

Pin,Clevis,0.50 Dia.X 2.00 Lg, 2-145
Pin,Clevis,0.50 Dia.X 3.50 Lg, 2-133, 2-135
Pin,Clevis,1.00 Dia.X 2.50 Lg, 2-33
Pin,Hair Cotter #Lhcot-2,Leitk, 2-137, 3-35
Pin,Roll,.18Odx1.62L,.187/.192, 3-59, 3-61
Pin- Cotter .094X0.75, 3-65, 3-67
Pin, 2-29, 2-39, 2-41, 2-137, 3-35, 4-26, 5-9, 5-15,
5-19
Pipe Wldt, Exhaust, Gas/Lpg, 2-89
Piston Assembly 0.003 O/S, 5-19
Piston Assembly 0.020 O/S, 5-19
Piston Assembly 0.030 O/S, 5-19
Piston Assembly 0.040 O/S, 5-19
Piston Assembly Standard – Blue, 5-19
Piston Assembly Standard – Red, 5-19
Piston Pin , 6-20
Piston, Servo, 4-7, 4-15
Piston, Std. , 6-20
Pivot Wldt, Wheel, 2-111
Planet Bearing , 5-21, 6-9
Plate & Brg , 5-21, 6-9
Plate , 6-17
Plate Wldt., 2-95
Plate Wldt, Adj, Brush, 2-147
Plate Wldt, Cover, 2-139, 3-31
Plate Wldt, Link, Lh, 2-47
Plate Wldt, Link, Rh, 2-47
Plate Wldt, Mtg, Motor, Lh, 2-59, 2-61
Plate Wldt, Mtg, Motor, Rh, 2-59, 2-61
Plate Wldt, Skirt, 3-63
Plate Wldt, Vac Door, 3-59, 3-61
Plate Wldt, 2-141, 3-33, 3-53
Plate, Adj, Brush, 2-149
Plate, Angle, 2-137, 2-139, 2-141, 3-33, 3-35
Plate, Backing, Handle, 3-19, 3-23
Plate, Backing, 2-55, 2-99, 2-101
Plate, Circuit Breaker, 2-161
Plate, Cover En, 4-3, 4-7, 4-11, 4-15
Plate, Cover, 2-37, 2-141
Plate, Damper, Inlet, 3-21
Plate, Damper, Outlet, 3-21
Plate, Drip Shield, 2-65
Plate, Engine Rear, 2-59, 2-61
Plate, Guide, Bumper, 2-7, 2-9
Plate, Latch, 3-61
Plate, Lever, 3-21
Plate, Link, 2-29
Plate, Mounting, Rfs Control, 3-75
Plate, Mounting, Tank, Gas, 2-93
Plate, Mounting, Vac Door, 3-59, 3-61
Plate, Mounting, Water Pump, 2-57
Plate, Mtg, Check Valve, 3-35
Plate, Mtg, Latch, 2-143
Plate, Mtg, Relay, 2-161
Plate, Mtg, Steering Boot, 2-157
Plate, Mtg, Tank, Gas, 2-91
Plate, Mtg, Valve, Solenoid, 2-131
Plate, Mtg, 2-95
Plate, Pin Retainer, 2-29, 2-33
Plate, Pivot, Wheel, 2-111
Plate, Retainer, Foam, 2-155
Plate, Retainer, 3-63
Plate, Seal, 2-143
Plate, Shim, Bumper, .06 Thk, 2-47
Plate, Shim, Hopper, 2-47
Plate, Shutter, 3-75
Plate, Side Brush Roller, 2-141
Plate, Side Brush, Roller, 3-33
Plate, Spacer, Mtg, Eng 2.3Fd, 2-63
Plate, Spacer, 2-33
Plate, Spring – Side Brush, 2-101, 2-151, 2-153
Plate, Spring, Side Brush, 2-99
Plate, Striker, 2-25
Plate, Support, Cover Se, 3-65, 3-67
Plate, Tapped, 2-147
Plate, Vac Fan, 2-153
Plate, Wear, 4-26
Plate-Cover, 2-141
Plate, 2-106, 2-119, 2-141, 3-11, 3-13, 3-33, 3-45,
3-59, 3-61, 3-63, 3-65, 3-67, 4-19, 5-9, 5-15
Plug .06 O/S , 6-3
Plug & O-Ring En, 4-37
Plug #2, 4-31, 4-33, 4-35
Plug #8, 4-3, 4-7, 4-11, 4-15
Plug – 0.060 O/S, 5-3
Plug – 1.50 Cup, 5-3, 5-6

CROSS REFERENCE

Plug – 1/4 NPT, 5-3, 5-6, 5-15
Plug – 3/8 Cup, 5-3
Plug – 3/8 NPT, 5-3
Plug – Engine Oil Drain , 5-11
Plug – Hole in Front Cover, 5-7
Plug – Oil Pump Relief Valve, 5-11
Plug , 5-3, 6-17
Plug 1/4 Npt, 6-3, 6-6
Plug 3/8 Npt , 6-3
Plug 3/8 NPT, 6-14
Plug Assembly En, 4-37
Plug Assembly, 4-19
Plug Assy,Byd En, 4-37
Plug En, 4-5, 4-9, 4-13, 4-17, 4-39
Plug Gage #4, 4-31, 4-33, 4-35
Plug Gage #6, 4-31, 4-33, 4-35, 4-37
Plug S/A En, 4-3, 4-7, 4-11, 4-15
Plug Weld, Brush Drive, Sweep, 2-143
Plug Wldt, Idler, 2-143
Plug, #2 O–Ring, 4-29
Plug, 1.50 Cup , 6-3
Plug, 1/2Npt, 6-14
Plug, Drain, 3-59, 3-61
Plug, Standard – 2.078 OD, 5-3
Plug, Tube, 2-143
Plug,#12 O–Ring Ph, 4-3, 4-7, 4-11, 4-15
Plug,1.50 Cup , 6-6
Plug–Std 2.078, 6-3
Plug, 4-25, 4-41, 6-7
Plugbtn .62H .03–.12 Blacknyl, 2-161
Plunger En, 4-37
Poppet En, 4-5, 4-9, 4-13, 4-17, 4-37
Poppet, 4-25
Pulley – Cable, 1.5 Dia, 2-139, 3-31, 3-33
Pulley Assy, Cable, 1.5 Dia, 2-141
Pulley, Alternator, 2-55, 2-57
Pump – Includes Gasket – 5/8 Pilot, 5-22
Pump, Fuel, 2-65, 2-93
Pump, Gear, 4-18
Pump, Hyd Piston V 2.48 (see breakdowns), 3-73
Pump, Hyd Piston V 2.48 R4500, 4-7, 4-9, 4-15, 4-17
Pump–Hyd Gear Ex (See Breakdowns), 2-121

Pump–Hyd Piston V (See Breakdowns), 2-121
Pump–Hyd Piston V 2.48 R4500, 4-3, 4-5, 4-11, 4-13
Pump, 5-11

R

Race, Bearing Ce, 4-3, 4-7, 4-11, 4-15
Race, Bearing, 4-25, 4-26
Race, Thrust, 4-20, 4-21, 4-22
Radiator, 4 Row, 6 Fin, 2-101
Radiator, 2-99
Rear Glass Asy–Cab, 3-43
Rear Glass Asy–Door, 3-45
Rear Plate, 6-15
Rectifier, 2-55, 2-57
Regulator, 2-55, 2-57
Reinforcement – Oil Pan Flange , 5-11
Reinforcement – Oil Pan Flange, 5-11
Relay, Shrouded, 12 Vdc, 2-161, 3-11, 3-13, 3-75
Relay, Shrouded, 12V, 3-3, 3-5, 3-7, 3-9
Relief Cart., 4-36
Relief Valve Sa En, 4-5, 4-9, 4-13, 4-17
Repair Info, Motor, 4-21, 4-22
Repair Info,Cyl En, 4-43
Repair Info,Pmp En, 4-5, 4-9, 4-13, 4-17
Repair Info,Scu Cl, 4-26
Repair Kit, Fuelock, 2-73
Replacement Kit, Battery Door (Gasoline), 2-7
Replacement Kit, Battery Door (LPG), 2-7
Replm Kit, Case, 2-159
Replm Kit, Cir Board, 2-159
Replm Kit, Hourmeter, 2-159
Replm Kit, Instr Panel , 2-159
Replm Kit, Lamp, Backlighting (Set of 8), 2-159
Replm Kit, Lamp, Fault (Set of 8), 2-159
Replm Kit, Seal, 2-159
Replm Kit, Touch Panel , 2-159
Replm. Kit , Bumper, LPG, 2-9
Replm. Kit, Bumper, Gas, 2-9
Retainer , 5-21, 6-9
Retainer Replacement Kit, 2-141
Retainer, Frt, 4-19
Retainer, 5-17

Retaining Ring , 5-21, 6-9
 Retaining Ring–External, 1.25D, 2-31, 2-33
 Retaining Rng En, 4-37
 Retnr.Gear , 5-21, 6-9
 Rfs Kit, 3-75
 Ring Set 0.020 O/S, 5-19
 Ring Set 0.030 O/S, 5-19
 Ring Set 0.040 O/S, 5-19
 Ring Set Standard and .003 O/S, 5-19
 Ring Set,Std. , 6-20
 Ring Wldt, Mtg, Filter, 2-51
 Ring Wldt, Shaker, 2-51
 Ring, Isolator, Outer Rbr, 2-101, 2-153
 Ring, Isolator, Outer, Rbr, 2-51, 2-99, 2-151
 Ring, Rear Window, 3-43
 Ring, Retainer, Lock, 2-111
 Ring, Retainer, 4-25, 4-26
 Ring, Retaining En, 4-5, 4-9, 4-13, 4-17, 4-39
 Ring, Retaining, Ex 1.5 Dia Hd, 2-27, 2-29
 Ring, Retaining, Ext 1.12, 2-51
 Ring, Retaining, 4-41
 Ring,Retain,Ex,0.50 Stl Steel, 2-119
 Ring,Retain,Ex,0.50Od,Heavy Dt, 2-157
 Ring–Drv.Stop , 5-21, 6-9
 Ring, 2-133, 2-135
 Rivet, Plastic .250X.898, 3-65, 3-67
 Rivet, Plastic .325D X .787, 2-15
 Rivet, Plastic, 2-10, 2-11
 Rod , 6-17
 Rod Support, Cover, 3-65, 3-67
 Rod Wldt, Adjustment, 2-117
 Rod Wldt, Brush Pressure, 2-147
 Rod Wldt, Push, Brake, 2-117
 Rod Wldt, Seat, 2-13
 Rod, Actuator, Control, 2-65, 2-69
 Rod, Cam Adjuster, 2-139, 3-31
 Rod, Inlet, 3-21
 Rod, Latch, Steering, Tilt, 2-157
 Rod, Push, 3-25
 Rod, Seat, 2-15, 3-65, 3-67
 Rod, Thread, 2-141, 2-149
 Rod, Threaded .50–13, 2-145

Rod–Thrd 2End M08X1.3 X 7.87, 2-65, 2-69
 Rod–Thrd, 1End M06X1.0 X 6.40, 2-17
 Rod–Thread, 2End M08X1.25X10Lg, 2-117
 Rod–Thread, Full M10X1.5 X1.50, 2-139, 3-31
 Roll Pin En, 4-5, 4-9, 4-13, 4-17
 Rotating Kit, 4-3, 4-7, 4-11, 4-15
 Rotor – Distributor, 5-23

S

Scr Set .31–18X0.50, 3-31
 Scr Set M 6X1.0 20 , 2-133
 Scr Soc .38–16X0.75 , 2-157
 Scr Soc M10X1.5 25, 2-65
 Scr Soc M10X1.5 25, 2-69
 Scr&Wash M6 , 6-17
 Scr&Wsh,M6X15.0M, 6-19
 Scr&Wsh,M6X22.5, 6-7
 Scr–Set 10–24X0.25 Nylon Loc, 3-75
 Scr–Shld .500Dx0.50L .38–16, 2-7, 2-9
 Screen, Filter, 2-51
 Screen, Guard, Lower, 2-105
 Screen, Guard, 2-103, 2-105
 Screen, Muffler, 2-89
 Screen, Tube, and Cover Assy – Oil Pump, 5-11
 Screw and Washer – M6X12, 5-15
 Screw and Washer – M6X16, 5-17
 Screw and Washer – M8X25, 5-11
 Screw and Washer – M8X30, 5-11
 Screw and Washer, 5-9
 Screw Set M 6X1.020, 2-135
 Screw, Cap En, 4-7, 4-9, 4-15, 4-17
 Screw, Cap En, 4-3, 4-5, 4-11, 4-13
 Screw, Cap, 4-3, 4-7, 4-11, 4-15, 4-19
 Screw, Set En, 4-39
 Screw, Set, 2-143, 4-41
 Screw,M5X10.4M , 5-21, 6-9
 Screw,M6X22.5mm , 6-7
 Screw,M6X35.3M , 5-21, 6-9
 Screw–Hex M10X1.5 90 Full Thd, 2-137
 Screw–Hex M10X1.5, 2-137
 Screw–Set M10 X 1.50 2045H, 2-119
 Screw, 4-21, 4-22

CROSS REFERENCE

Seal Cw, 3-43
Seal Kit, 4-20, 4-21, 4-22
Seal – Front Cover, 5-5
Seal – Front, 5-5, 5-9, 5-13, 5-15
Seal – Rear – 1 Piece, 5-5, 5-13
Seal – Thermostat, 5-22
Seal – Valve Stem – Standard, 5-5
Seal , 5-21, 6-9
Seal Foam Rbr .75 1.5W 2.1L, 2-9
Seal Foam Rubber .75X1.5X3.5, 2-143
Seal Kit, COil CP, 4-31, 4-33
Seal Kit, Cab, 3-43
Seal Kit, Cart CP, 4-31, 4-33, 4-35
Seal Kit, Cart., 4-28
Seal Kit, Cart, 4-29
Seal Kit, Coil CP, 4-35
Seal Kit, Coil, 4-28, 4-29
Seal Kit, Cyl, 4-43
Seal Kit, Hyd Mtr Gear, 4-24
Seal Kit, Motor, 4-19
Seal Kit, One Cart, 4-27
Seal Kit, Pump En, 4-7, 4-9, 4-15, 4-17
Seal Kit, Pump En, 4-3, 4-5, 4-11, 4-13
Seal Kit, Scu, 4-26
Seal Kit, Shaft, 4-19
Seal Kit, Shaker Panel, 2-51
Seal Kit, Vlv En, 4-37
Seal Kit,Cntrl En, 4-39
Seal Kit,Cntrl, 4-41
Seal Kit,Stg, 4-25
Seal Kit, 4-18, 4-23, 4-36, 4-42
Seal, 24.5 Lg, 2-13
Seal, 27.25L, 2-13
Seal, 33.00 Lg, 2-13
Seal, 48.0 Lg., 2-13, 2-15, 2-23
Seal, 66.0 Lg, 2-13
Seal, 7.00 Lg, 2-15
Seal, Bearing, 2-157
Seal, Boot, Steering Column, 2-157
Seal, Brush Comp, Side , 2-11
Seal, Brush Comp, Side, 2-3, 2-10
Seal, Brush Door, 2-10, 2-11
Seal, Bulb, Sd–0504 19.75Lg, 3-65, 3-67
Seal, Bulb, Sd–0504 24.50Lg, 2-15
Seal, Bulb, Sd–0504 28.00 Lg, 2-15
Seal, Door, Brush, Lh, 2-10
Seal, Door, Brush, Rh, 2-11
Seal, Duct, 2-99, 2-101
Seal, Dust, 2-35, 2-37, 2-51, 2-119
Seal, Exhaust – 0.015 O/S, 5-17
Seal, Exhaust – 0.030 O/S, 5-17
Seal, Exhaust – Standard, 5-17
Seal, Fan, Vac Outlet, 2-101
Seal, Foam Rbr .19 .75W 8.43L, 3-59, 3-61
Seal, Foam Rbr .75 1.5W 2.1L, 2-7
Seal, Foam Rbr, .19 .75W 47.1L, 3-59, 3-61
Seal, Foam, Urethane Covered, 2-37
Seal, Foam, 2-7
Seal, Handle, Valve, 2-159
Seal, Intake – 0.015 O/S, 5-17
Seal, Intake – 0.030 O/S, 5-17
Seal, Intake – Standard, 5-17
Seal, Main Brush, 2-7
Seal, O–Ring .787Idx.210Th, 3-75
Seal, Pan, Top, 2-3, 2-7, 2-9
Seal, Rear , 6-5
Seal, Rod, Adjuster, 2-15, 2-149
Seal, Rod, Brush Pressure, 2-147
Seal, Rubber, Propel Pedal, 2-119
Seal, Urethane Covered Foam, 2-45
Seal, Urethane, 2-39, 2-43, 3-75
Seal,Foam Rbr, .31 .75W 14.8L, 2-13, 2-15
Seal,Foam Rbr, .62 .62W 24.5L, 2-17, 2-19, 2-21,
2-23
Seal,Valve Stem, 6-5
Seal, 2-9, 2-15, 3-61, 3-75, 5-5
Seat Belt Kit, 3-72
Seat, Suspension, 2-13, 2-15
Seat, 4-25, 5-17
Send Unit, Temperature, 2-55, 2-57
Send Unit, 2-91, 2-93
Sender, Filter, Hydraulic, 2-105, 3-57
Sensor,Crnksft, 6-7
Separator , 6-3
Service Manual FD, 3-76

Servo Piston Sa En, 4-3, 4-11	Side Brush Lever Adjustmt Kit, 2-139
Set Screw, 2-51	Skirt, Air Cleaner, Se, 3-65, 3-67
Shaft and Brg, 4-19	Skirt, Brush Door, 2-3, 2-10, 2-11
Shaft Assembly – Oil Pump Intermediate, 5-11	Skirt, Cover, Sbdc, 3-63
Shaft Wldt, Main Brush, 2-143	Skirt, Deflection, 3-63
Shaft Wldt, 3-59	Skirt, Deflector, 2-35, 2-37
Shaft, Drive Sp En, 4-3, 4-7, 4-11, 4-15	Skirt, Front, Indoor, 2-3, 2-10, 2-11
Shaft, Eccentric, 2-51	Skirt, Lip, 2-35, 2-37
Shaft, Idler, 2-143	Skirt, Retainer, 3-63
Shaft, Input En, 4-39	Skirt, Seal, Main Brush, 2-3, 2-7, 2-9
Shaft, Input, 4-41	Skirt, 3-63
Shaft, Pivot, 2-137, 3-35, 3-75	Sleeve .438B 1.00D .35Stl, 3-33
Shaft, 3-61, 4-21, 4-22, 5-9	Sleeve, .259B .38D .62 Dom, 2-133
Shaker Bar Replacement Kit, 2-51	Sleeve, .259B .38D .62 Dom, 2-135
Sheave, Alternator, Se, 3-57	Sleeve, .320B .32D .49 Lc Stl, 2-43
Sheave, Crankshaft, 2-55	Sleeve, .320B .32D .49 Lc Stl, 2-45
Sheave, Eng Crank,Fd W/Tg 2Gr, 2-57	Sleeve, .344B .50D .81 Cr.Anc, 2-117
Sheave, Water Pump, 2-55, 6-21	Sleeve, .370B .50D .38 Cd.Znc, 2-47
Shft Asy,Output, 5-21, 6-9	Sleeve, .375B .62D1.06 Stl, 2-111
Shield, Distributor, 2-55	Sleeve, .375B .75D .75 Stl, 2-139, 3-31
Shield, Dust, 2-7, 2-9	Sleeve, .375B .75D .32 Stl, 2-139, 2-141, 3-31, 3-33
Shim .003Th 0.88Odx0.506ld, 2-153	Sleeve, .380B .62D .50 Smls, 2-117
Shim .005Th 0.88Odx0.506ld, 2-153	Sleeve, .380B .62D .66 Smls, 2-117
Shim .010 Thk En, 4-37	Sleeve, .385B .62D .62 Cd.Cad, 2-13, 2-15
Shim .010Th 0.88Odx0.506ld, 2-153	Sleeve, .408B .62D .53Stl, 2-119
Shim .015 Thk En, 4-37	Sleeve, .438B 1.00D .35 Stl, 2-141
Shim .020Th 0.88Odx0.506ld, 2-153	Sleeve, .500B .69D1.281Cr.Cad, 2-59
Shim .035 Thk En, 4-37	Sleeve, .500B .69D1.281 Cr. Cad, 2-55
Shim .060Th 0.880Dxo.506ld, 2-153	Sleeve, .500B .69D1.281Cr.Cad, 2-61
Shim – 0.030 Thick – 1.0 ID, 5-17	Sleeve, .531B .99D1 .75 Stl, 2-39
Shim Vac Fanassy, 2-153	Sleeve, 0.406B .750D .800Stl, 3-33
Shim..005Th 0.88Odx0.506ld, 2-151	Sleeve, 0.406B 0.75D1.80 Stl, 2-141, 3-33
Shim, Door Striker, 3-45	Sleeve, Bearing, 2-51
Shim, Vac Fan Assy, 2-151	Sleeve, Hyd 30", 2-143
Shim,.003Th 0.88Odx0.506ld, 2-151	Sleeve, Nylon #27 65.0L, 2-137
Shim,.010Th 0.88Odx0.506ld, 2-151	Sleeve, Nylon #27 55.Ol, 3-35
Shim,.020Th 0.88Odx0.506ld, 2-151	Sleeve, Pivot, Door, 2-41
Shim,.060Th 0.880Dxo.506ld, 2-151	Sleeve,0.406B .750D .800 Stl, 2-141
Shim, 2-31, 2-49	Sliding Glass, 3-45
Shims En, 4-5, 4-9, 4-13, 4-17	Solenoid , 5-21, 6-9
Short Tube , 6-3	Spacer .77Od .406ld 1.318Lg, 3-31
Shoulder Screw, 2-51	Spacer – Cover, 5-7

CROSS REFERENCE

Spacer En, 4-37
Spacer Plate, 4-21, 4-22, 4-25
Spacer, .25 L, 2-135
Spacer, .90L, 2-135
Spacer, Alternator Arm, 2-55
Spacer, Brake, 2-117
Spacer, Glass, 3-43
Spacer, Pulley, 2-139, 2-141, 3-31, 3-33
Spacer-.50 Od X .055W X 1.0, 2-117
Spacer, 2-31, 2-33, 2-47, 2-99, 2-101, 2-117, 2-119,
2-137, 2-139, 2-141, 2-151, 2-153, 3-19, 3-31,
3-33, 3-35, 3-43, 6-14
Spark Plug-10 FD, 2-3
Spark Plug, 5-23, 6-22
Spindle, Adjustment, 2-17, 2-19, 3-65, 3-67
Sponge Cord 1.5Dia, 2-7
Spring En, 4-37
Spring – Tensioner, 5-15
Spring Assy, Recirculation, 2-7
Spring En, 4-5, 4-9, 4-13, 4-17, 4-37
Spring Kit, 4-36
Spring, Cntr En, 4-39
Spring, Cntr, 4-41
Spring, Comp. Cl, 4-25
Spring, Comp, 2-137, 3-35
Spring, Extension, 2-137, 3-35
Spring, Gas 80 Lb, 3-49
Spring, Gas, 2-19
Spring, Propel, Centering, 2-119
Spring, Recirculation, 2-9
Spring, Tens,0.5Dx.06Wire 2.5L, 2-117
Spring, Tension, 2-103, 2-145, 6-17
Spring, Torsion , Rh, 2-137
Spring, Torsion, 3-35
Spring,Retainer En, 4-39
Spring,Retainer, 4-41
Spring-Gas 120Lb 6.3 Stroke, 2-17
Spring-Gas 75Lb 6.3 Stroke, 2-17
Spring-Gas Assy, 2-43
Spring-Gas, Engine Cover, 2-45
Spring, 2-51, 4-19, 5-17
Sprng, Tens,1.000dx.09Wire2.8 L, 2-119
Sprng,Comp,0.62Idx.06Wire 2.3L, 2-157
Sprng,Comp,0.74Idx.11Wire 1.5L, 3-21
Sprng,Comp,0.83Idx.07Wire 1.0L, 3-59, 3-61
Sprng,Comp,0.87Idx.10Wire 2.5L, 2-147, 2-149
Sprng,Tens,0.37Odx.05Wire 4.5L, 2-17, 3-25
Sprng,Tens,0.965Odx.09Wire4.4L, 2-43, 2-45, 3-21
Sprocket, 5-9, 5-13, 5-15
Statnry Gear , 5-21, 6-9
Stator Assembly, 5-23
Std.Exh.Valve , 6-19
Std.Int.Valve , 6-19
Steer Control Hyd#4 04.5 1300, 4-26
Steer Control, Hyd#4 04.5 1300, 4-25
Steer Control, Hyd, 2-157
Strain,Relief, 2-53, 3-75
Strainer-Hyd Suction 25-100-03, 2-3, 2-129
Strap Weldmt, Gas Tank, 2-91, 2-93
Strap Wldt, A/C Cover, 3-51
Strap, Coil, 2-55
Strap, Hinge – Lp Tank Mtg, 2-95
Strap, Mtg.- Lp Tank, 2-95
Strap, Mtg, Air Cleaner, 3-51
Strap, Mtg, Fueline, 2-65
Strap, Retainer, Seal, 2-3, 2-7, 2-9
Strap, Shipping En, 4-5, 4-13
Strap, Tank Retainer – Lp, 2-95
Striker Assy, 3-45
Strip, Edging, 2-9
Strip, Hopper, 2-37
Strip, Retainer, Bearing, 2-143
Strip, Retainer, Brake Cable, 2-117
Strip, Retainer, Seal, Lh, 2-10
Strip, Retainer, Seal, Rh, 2-11, 2-139, 3-31
Strip, Retainer, Seal, Side, 2-10, 2-11
Strip, Retainer, Shield, Lh, 2-7, 2-9
Strip, Retainer, Shield, Rh, 2-7, 2-9
Strip, Retainer, Skirt, Front, 2-35, 2-37
Strip, Retainer, Skirt, Rear, 2-35
Strip, Retainer, Skirt, 2-3, 2-10, 2-11, 3-63
Strip, Spacer, 2-17, 2-19
Strip, 2-17, 3-53, 3-55
Stud – M12-M10X109, 5-13
Stud – M8-M6X47.1, 5-14

Stud – M8X49, 5-7, 5-15
 Stud , 6-21
 Stud M12 , 6-3
 Stud, Adjustment, 3-59, 3-61
 Stud, Ball, Gas Spring, 2-17, 2-19, 2-139, 3-31
 Stud,Air Cleaner Gas .25–20, 2-65
 Stud,M6X61.8mm , 6-7
 Stud,M8X51.0mm, 6-7
 Stud, 6-14
 Support Wldt, Hopper Lh, 2-49
 Support Wldt, Sppt, Hopper Lh, 2-49
 Switch Assy, Hopper, Angle, 2-47
 Switch Assy, Pressure, Hyd, 2-131
 Switch Brkt Heat De, 4-49, 4-51
 Switch Ignition, 2-159
 Switch Rocker Spst, 2-141, 3-33
 Switch, Blower, 4-45, 4-47, 4-49, 4-51
 Switch, Pressure Oil, 2-57
 Switch, Pressure, Lpg, 2-73, 2-75
 Switch, Pressure, Oil, 2-55
 Switch, Pressure, 2-53, 3-75
 Switch, Pushmom, Spst100A 12V, 2-157
 Switch, Rocker, Dpdt, 2-159
 Switch, Roller, 2-29, 2-139, 3-15, 3-16, 3-31
 Switch, Thermo, 4-45, 4-47
 Switch, Wiper Motor, 3-43
 Switch,Lockout En, 4-39
 Swivel, 3-21

T

Tab, Fuelline, 2-91
 Tank Wldt, Hyd , 2-129
 Tank Wldt, Hydraulic, 2-129
 Tank, Fuel, 2-91, 2-93
 Tank–Lp, 33#,Liq,Both,Fill Ga, 2-95
 Tap.Assy–Valve , 6-19
 Tappet Valve 0.020 O/S, 5-17
 Tappet Valve Standard, 5-17
 Temperature sensor, 6-21
 Tens.Asy&Tbelt, 6-17
 Tensioner Assembly, 5-15
 Term.Cover , 5-21, 6-9

Therm 190 W/Gsk, 6-21
 Thermostat And Seal Assembly – 170_F, 5-22
 Thermostat Assembly, 155 Deg, 2-155
 Thr.Brg,.002 Upper, 6-13
 Thr.Brg,.010 Upper, 6-13
 Thr.Brg,.020 Upper, 6-13
 Thr.Brg,.030 Upper, 6-13
 Thr.Brg,Stdblue, 6-13
 Thr.Brg,Stdred , 6-13
 Thrust Bearing – Lower , 5-13
 Thrust Bearing – Lower 0.002 U/S, 5-13
 Thrust Bearing – Lower 0.010 U/S, 5-13
 Thrust Bearing – Lower 0.020 U/S, 5-13
 Thrust Bearing – Lower 0.030 U/S, 5-13
 Thrust Bearing – Lower Standard Red, 5-13
 Thrust Bearing – Upper , 5-13
 Thrust Bearing – Upper 0.002 U/S, 5-13
 Thrust Bearing – Upper 0.010 U/S, 5-13
 Thrust Bearing – Upper 0.020 U/S, 5-13
 Thrust Bearing – Upper 0.030 U/S, 5-13
 Thrust Bearing – Upper Standard Red, 5-13
 Tie Cable 3.00D Max 11.41Lg, 2-137, 3-35
 Tie, Cable 1.75D Max 7.50Lg, 2-53
 Tie, Cable 1.75D Max 7.50Lg, 3-11, 3-13, 3-75
 Tie, Cable 3.00D Max 11.41Lg, 2-157
 Tie, Cable 4.00 Max 14.50Lg, 3-75
 Tie, Cable, 3-3, 3-5, 3-7, 3-9
 Timing Belt , 6-17
 Tire & Flap Assy, 2-115
 Tire & Rim Assy, Pneu 6.50–10, 2-115
 Tire and Rim Assembly, Solid 6.50–10, 3-70
 Tire and Rim Assy, Rear, Solid 6.5, 3-71
 Tire, Solid, 3-70, 3-71
 Tread, Floormat, Rubber, Cab, 3-43
 Tread, Floormat, Rubber, 2-13, 2-15
 Triple Sheave, 5-13
 Tube Assy, Brake,Metric 34.0Lg, 2-117
 Tube Assy, Brake,Metric 80.0Lg, 2-117
 Tube Assy, Brake, 2-117
 Tube Assy, Fuel .31Od, 2-93
 Tube Wldt, Air Cleaner, 2-81, 2-83, 2-85, 2-87, 3-65, 3-67
 Tube Wldt, Brace, Center, 2-17, 2-19

CROSS REFERENCE

Tube Wldt, 2-77, 2-79, 2-83, 2-85
Tube, .75D .172W .75 Stl, 3-31
Tube, 0.62D .44B 2.44,Stl, 2-43
Tube, 0.62D .44B 2.44, Stl, 2-45, 3-49
Tube, 2.25D 2.130 4.50,Stl, 2-77
Tube, 2.50D 2.380 21.0,Stl, 2-77
Tube, 3.00D 2.88B 3.00,Stl Dom, 3-23
Tube, Air Cleaner, 2-77, 2-83, 3-67
Tube, Blower Wand, 3-19, 3-23
Tube, Cross, Bumper, Se, 3-27, 3-28, 3-29
Tube, Dipstick, 2-55
Tube, Fuelline, Gas/Die, 2-91
Tube, Fuelline, Gas, 2-65
Tube, Inner, 2-115
Tube, Intake, Gas, 3-67
Tube, Intake, Se, Gas, 3-65
Tube, Radiator, Lower, Gas/Lpg, 2-97
Tube, Radiator, Upper, Gas/Lpg, 2-97
Tube, Retainer, Spring, 2-145
Tube, Spacer, Brush Lift, 2-145

U

Use with 1 Piece Rear Seal, 5-13

V

V-Belt, A-45 Hy-T, 3-53
Vac.Fitting, 6-14
Valve – Hyd., Solenoid, 4-28
Valve Guide Bushing, 6-19
Valve Mountng Brkt De, 4-45, 4-47, 4-49, 4-51
Valve Plate, 4-5, 4-9, 4-13, 4-17, 4-19
Valve Rocker Arm , 6-19
Valve Rocker Arm Cover , 6-19
Valve Spool, 4-41
Valve Spring , 6-19
Valve Spring Key , 6-19
Valve Spring Retainer , 6-19
Valve Stem N.O. CP, 4-31, 4-33, 4-35
Valve Stem N.O., 4-27
Valve Stem 4W2P CP, 4-31, 4-33, 4-35
Valve Stem 4W2P, 4-29
Valve Stem Seal , 6-19

Valve Stem, N.D., 4-28
Valve, Check, 4-45, 4-47
Valve, Exhaust 0.015 O/S, 5-17
Valve, Exhaust 0.030 O/S, 5-17
Valve, Exhaust Standard, 5-17
Valve, Hyd Control Man (See Breakdowns), 2-135
Valve, Hyd Control Man, 4-37
Valve, Hyd Control Solenoid, 4-29, 4-35
Valve, Hyd Solenoid (See Breakdowns), 2-141
Valve, Hyd Solenoid, 2-141
Valve, Hyd, (Repl. by 77496) (See Breakdowns), 2-133
Valve, Hyd, Control Solenoid, 3-33
Valve, Hyd, Solenoid (See Breakdowns), 3-33
Valve, Hydraulic, 4-36
Valve, Intake Standard, 5-17
Valve, Intake 0.015 O/S, 5-17
Valve, Intake 0.030 O/S , 5-17
Valve, PCV, 2-3
Valve, Pcv, 2-55
Valve, Press Relief, Lpg Rego, 2-95
Valve, Push Nut Water, 4-45, 4-47, 4-49, 4-51
Valve-Hyd, Cntl Solenoid, 4-31
Valve-Hyd, Solenoid (See Breakdowns), 2-131, 2-155, 3-35
Valve-Hyd, Solenoid , 2-155
Valve-Hyd, Solenoid, 4-27, 4-33
Valve, 4-19
Vaporizer Repair Kit, 2-73, 2-75
Vaporizer, Lpg, 2-73, 2-75
Vlv Spool Wide En, 4-39

W

Wand Kit, Vac, 3-61
Wand Kit, Vacuum, 3-59
Wand, 3-59, 3-61
Warning Kit, Backup Low Blower, 3-16
Warning Kit, Backup, 3-15
Warning Label, Starter, 6-19
Wash M15 1.53Od , 6-13
Washer – “C” Type, 5-23
Washer – M15 – Pulley To Crankshaft, 5-13
Washer – Sprocket to Camshaft, 5-15

Washer , 5-21, 6-9, 6-11, 6-17
Washer En, 4-3, 4-5, 4-7, 4-9, 4-11, 4-13, 4-15, 4-17,
4-37
Washer, .281B .62D .06Nylon, 2-65
Washer, .281B .62D .06Nylon, 2-67
Washer, .310B .88D .12Rbr, 2-39, 3-35
Washer, .344B .69D .06Nylon, 3-75
Washer, .531B 1.75D .12Cr.Znc, 2-143
Washer, .531B 1.88D .12Hard Zn, 2-15, 2-63
Washer, .532B 2.13D .11Hr.Znc, 2-59
Washer, .532B 2.13D .11Hr.Znc, 2-61, 2-63
Washer, 1.015B 1.75D .11Hrs, 2-41
Washer, 1.300B 3.000, 2-137, 3-35
Washer, Flat, 2-13
Washer,1.142B 1.75D .07 Lcs, 2-31
Washer,Lock Special, 2-111
Washer,Nyl,0.26 Bx0.72 X.07 Th, 3-21
Washer,Nyl,0.405Bx0.812X.060Th, 3-31
Washer–Belleville .31 Pltd, 3-33
Washer–Belleville .50 Pltd, 2-137
Washer–Belleville .50 Pltd, 3-35
Washer–Flt .31 Fender Pltd, 2-133
Washer–Flt .25 Fender Rltd., 2-15
Washer–Flt .31 Fender Pltd, 2-135
Washer–Flt 15.0 X 37.0 X 5.5 M15, 2-55
Washer–Loc Int–Ext .31 Pltd, 3-41
Washer, 2-53, 2-111, 4-3, 4-7, 4-11, 4-15, 5-9, 5-13
Water Outlet, 5-22
Water Outlet, 6-21
Water Pump , 6-21
Water Screen Foam De, 4-45, 4-47
Water Valve, 4-45, 4-47, 4-49, 4-51
Weight, LPG/Gas, 2-9
Wheel, Steering, 2-157
Wire Ass'Y–Elect.,Ground, 2-61, 2-63
Wire Assy. Ground, 2-59
Wire Assy, 42.0 Lg, 2 Ga, Neg, 2-106, 2-107
Wire Assy, 66.0 Lg, 2 Ga, Pos, 2-106, 2-107
Wire Assy, Spark Plug (Set of Four), 2-55
Wire Asy,Spark Plug, 6-22
Wire Harness, 3-55, 4-45, 4-47, 4-49, 4-51, 6-22
Wire, 42.0 Lg, 2Ga, Neg, 2-109
Wire, Dome Light, 3-43

Fold along dotted lines

Tape here



NO POSTAGE
NECESSARY
IF MAILED
IN THE
UNITED STATES

BUSINESS REPLY MAIL
FIRST CLASS MAIL PERMIT NO. 94 MINNEAPOLIS, MN

POSTAGE WILL BE PAID BY ADDRESSEE

TENNANT COMPANY

Technical Publications #15
701 North Lilac Drive
P.O. Box 1452
Minneapolis, MN 55440-9947

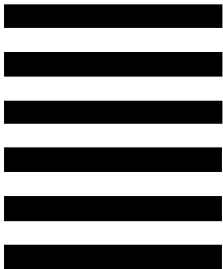

Fold along dotted lines

Tape here



NO POSTAGE
NECESSARY
IF MAILED
IN THE
UNITED STATES

BUSINESS REPLY MAIL
FIRST CLASS MAIL PERMIT NO. 94 MINNEAPOLIS, MN

POSTAGE WILL BE PAID BY ADDRESSEE

TENNANT COMPANY

Technical Publications #15
701 North Lilac Drive
P.O. Box 1452
Minneapolis, MN 55440-9947

