

MM028

3-84

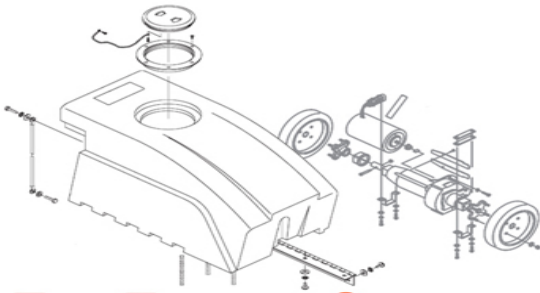

FLOOREQUIPMENTPARTS.COM

42E/EHD POWER SWEEPER

Operation, Maintenance, and Parts Manual

Parts Manual

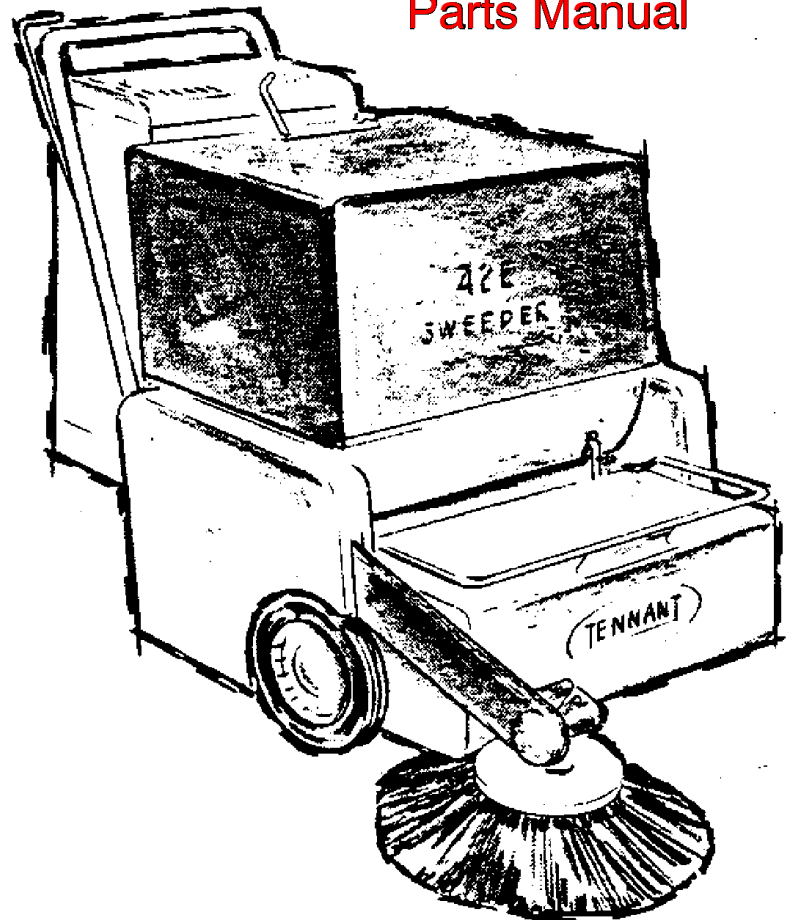

SPECIALIZED MAINTENANCE EQUIPMENT
SWEEPERS • SCRUBBERS • SCARIFIERS • FLOOR COATINGS



42E/EHD

POWER SWEEPER

This manual is furnished with each new TENNANT® Model 42E. The machine operators will easily learn how to operate the machine and understand its mechanical functions by following the directions and absorbing the information in the Operation section.

This machine will give excellent service and sweeping results, and save maintenance expenses. However, as with all specially engineered mechanical equipment, best results are obtained at minimum costs if:

- The machine is operated with reasonable care and
- The machine is maintained regularly — per the maintenance instructions provided.
- Components used in this machine have been carefully selected for performance and safety. Use only Tennant Company supplied or equivalent parts.

Parts and supplies may be ordered by phone or mail from any Tennant Company parts and service center, distributor, or from any of the Tennant Company subsidiaries.

The telephone, telex, mailing addresses, and locations are listed on the last page of the manual.

MANUAL NO. MM028
Published: 3-84

Trademark Registered in: Austria, Benelux, Denmark, England, France, Germany, Italy, Spain, Switzerland, United States, Argentina, Australia, Canada, Japan, Mexico, Sweden, by TENNANT COMPANY, Minneapolis, Minnesota, U.S.A.

02334

©1984, Tennant Company, Printed in U.S.A.



TENNANT COMPANY WARRANTY POLICY

Tennant Company warrants to the original purchaser, for the period of one (1) year from the date of delivery, that goods manufactured by it will be free from defects of workmanship and material, provided such goods are installed, operated, and maintained in accordance with Tennant Company written manuals or other instructions.

Tennant Company's sole obligation, and Purchaser's sole remedy under this warranty for all claims arising out of the purchase and use of the goods, shall be limited to the repair or replacement, at Tennant Company's option, of parts that do not conform to this Warranty.

For thirty (30) days from date of installation, Tennant Company will, at its option, provide labor for repair, pay for outside repair service, or pay the customer straight time in accordance with Tennant Company's flat rate schedule for particular warranty repairs. Thereafter, Tennant Company's sole obligation shall be limited to the repair or replacement, at Tennant Company's option, of parts that do not conform to this Warranty.

Repair parts supplied by Tennant Company are warranted for the period of thirty (30) days following installation. Tennant Company's obligation is limited to the replacement of the warranted part, and Tennant Company shall not be obligated to provide labor in installing such part.

Battery and tires will be replaced if failure occurs due to defective material or workmanship within 90 days from date of purchase. Thereafter, a pro rata adjustment from date of purchase to 12 months will be made. The pro rata adjustment price of the new battery and/or the new tire will be the Tennant Company current price as of the adjustment request less 1/12th of that price for each month remaining in the 12-month period. All warranty applies only to batteries and tires purchased from Tennant Company and installed in vehicles used in normal service.

Brushes that fail due to defective material or workmanship will be replaced on a pro rata basis within the first 12 months of purchase. The replacement price will be calculated by multiplying the current Tennant Company price by the percentage of usable bristle remaining at the time of adjustment.

No Warranty is made with respect to items made by others when such items are warranted by their respective makers or when they are supplied by Tennant Company on special order.

This Warranty shall not cover:

- A. Floor materials or application, and models 140 and 140E.
- B. Maintenance items, adjustments, or installation of machines.
- C. Repairs required as a result of failure due to normal wear, accidents, misuse, abuse, negligence, or improperly installed repair parts.
- D. Products altered or modified in a manner not authorized by Tennant Company in writing.

THIS WARRANTY IS EXPRESSLY IN LIEU OF ALL OTHER EXPRESSED OR IMPLIED WARRANTIES INCLUDING THE WARRANTIES OF MERCHANTABILITY AND FITNESS AND OF ALL OTHER OBLIGATIONS AND LIABILITIES ON THE PART OF TENNANT COMPANY, INCLUDING LIABILITIES FOR DIRECT, IMMEDIATE, SPECIAL, INDIRECT, OR CONSEQUENTIAL DAMAGES ARISING OUT OF THE FAILURE OF ANY MACHINE OR PART OF IT TO OPERATE PROPERLY, INCLUDING THE COST OR EXPENSE OF PROVIDING SUBSTITUTE EQUIPMENT OR SERVICE DURING PERIODS OF MALFUNCTION OR NON-USE.

This Warranty cannot be extended, changed, or modified by any representative of Tennant Company.

Dear Customer,

Keeping you as a satisfied customer is our primary concern. If for any reason you are not satisfied, please contact anyone of the persons listed below.

One of the addresses is your local engine dealer. We will handle replacements on all parts of our equipment but this dealer probably carries a more complete stock of engine parts than we do and should be able to give you faster service in this area. Try him first for engine parts. Also, your engine dealer should be contacted first for warranty claims pertaining to the engine.

If you find that you need an experienced mechanic, please contact anyone listed below and he will be happy to recommend a mechanic to you.

To get maximum trouble free service from your machine, you must perform maintenance checks as specified in the machine manual and arrange for maintenance on a regular basis. Remember that breakdowns are directly related to maintenance.

TENNANT COMPANY

Tennant Company
P. O. Box 1452
Minneapolis, MN 55440
(612) 540-1200

TENNANT COMPANY REPRESENTATIVE

ENGINE DEALER



SECTION 5 STANDARD MODEL PARTS

CONTENTS

	Page
Ordering Repair Parts.....	5-1
Fig. 1 - Recommended General Maintenance Items	5-2
Fig. 2 - Replacement Brushes.....	5-3
Fig. 3 - Main Frame Group	5-4
Fig. 4 - Battery Cover Assembly	5-5
Fig. 5 - Filter Box Assembly	5-6
Fig. 6 - Brush Drive Group	5-8
Fig. 7 - Side Brush Speed Reducer, Sweeper	5-10
Fig. 8 - Vacuum Fan Assembly	5-11
Fig. 9 - Drive Group	5-12
Fig. 10 - Hopper Assembly	5-14
Fig. 11 - Battery Group, Wet	5-15

NOTE: Section 5, Standard Model Parts, lists every repair part of a Standard Model 42E.

Home

Find...

Go To..



ORDERING REPAIR PARTS

To avoid errors or delays in filling parts orders, please furnish all of the following information.

1. Always specify the machine model number and the machine serial number shown on the machine data plate.

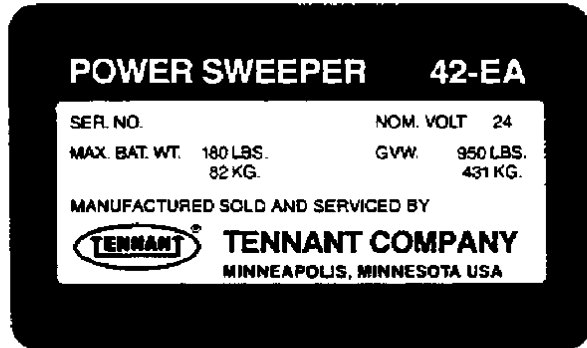

2. Give the part number, description, and the quantity needed of each item on the order. Do not order by reference number or the figure number of the illustrated parts.
3. Indented items indicate parts of assemblies. Standard hardware is furnished only when part of a purchased assembly. Please order hardware from a local hardware supplier.
4. If the old part cannot be identified, send it to us with the quantity needed specified on the order.
5. State definite shipping instructions to include the shipping address and/or the billing address if there is a difference. Any claim for loss or damage to a shipment in transit should be filed promptly against the transportation company making the delivery. Shipments will be complete unless the packing list or order acknowledgement indicate items back ordered.

If parts received are suspected to be incorrect or defective, please write, wire, or phone the Tennant Company representative from whom you ordered the part. They will give authorization for return and/or handle replacement shipments when required.

SI (INTERNATIONAL SYSTEM) UNITS OF MEASURE

Metric equivalents have been included, where applicable, throughout this parts catalog.

BOLT AND CAP SCREW STRENGTH IDENTIFICATION

Bolts and cap screws required to have high-strength qualities equivalent to SAE Grade 8 are identified throughout this catalog by the description GR 8. Unless identified by this description, all standard bolts and cap screws are SAE Grade 5.

SERIAL NUMBER INFORMATION EXPLANATION

Serial number information is listed parenthetically to show on which machines each part can be used. These listings are explained by the following examples:

() The part can be used on all machines.

(0000001234-) The part can be used on all machines beginning with the serial number listed.

(0000000000-0000001234) The part can be used on all machines up to and including serial number listed.

(0000001234-0000005678) The part can be used on all machines between and including the serial numbers listed.

Where XXXXX's are listed in place of a serial number, it indicates a serial number change was made but the exact serial number had not been established when the catalog went to press.

(Specifications and design subject to change without notice.)

FIG. 1 - RECOMMENDED GENERAL MAINTENANCE ITEMS

02331

KEY	TENNANT® PART NO.	MACHINE SERIAL NUMBER	DESCRIPTION	QTY.
	59458	(-)	REPLACEMENT PARTS PACKAGE	1
	28141	(-)	BELT	2
	28167	(-)	BELT	1
	22426	(-)	BELT	1
	28168	(-)	BELT	2
	28122	(-)	BELT	1
	28081	(-)	LIP, Pan	2
	28071	(-)	SKIRT, Rear	1
	28072	(-)	SKIRT, Side	2
	28068	(-)	SKIRT, Top pan	1
	28069	(-)	SEAL	1
	28139	(-)	SEAL	1
	04930	(-)	FUSE, 60 A	1
	31051	(-)	FUSE, 15 A	1
	31052	(-)	FUSE, 15 A	1
	59459	(-)	REPLACEMENT PARTS PACKAGE, Scrub	1
	29539	(-)	BLADE, Squeegee	1
	29540	(-)	BLADE, Backup	1
	29383	(-)	BLADE, Squeegee	1
	29601	(-)	HOSE	1
	26161	(-)	BELT	1
	29693	(-)	HOSE	1
	29474	(-)	HOSE	1
	29691	(-)	HOSE	1

FIG. 2 - REPLACEMENT BRUSHES

02330

KEY	TENNANT® PART NO.	MACHINE SERIAL NUMBER	DESCRIPTION	QTY.
1	28002	(-)	MAIN BRUSH, 6 Row, wire and fiber	1
1	28006	(-)	MAIN BRUSH, 6 Row, union mix	1
1	28006N	(-)	MAIN BRUSH, 6 Row, herox	1
1	28007P	(-)	MAIN BRUSH, 6 Row, polypropylene	1
1	28234	(-)	MAIN BRUSH, 50 Row, tampico	1
1	28172	(-)	MAIN BRUSH, 18 Row, natural fiber	1
1	28235	(-)	MAIN BRUSH, 18 Row, wire and fiber	1
1	29006	(-)	MAIN BRUSH, Scrubbing, 18 row, stainless steel	1
1	28660	(-)	MAIN BRUSH, 6 Row, wire	1
1	29408	(-)	MAIN BRUSH, Scrubbing, 24 row, polypropylene	1
2	28096N	(-)	SIDE BRUSH ASSEMBLY, Nylon	1
3	45154	(-)	HUB, Side brush	1
	28096P	(-)	SIDE BRUSH ASSEMBLY, Polypropylene	1
	45154	(-)	HUB, Side brush	1
	29406	(-)	SIDE BRUSH, Scrubbing, polypropylene	1

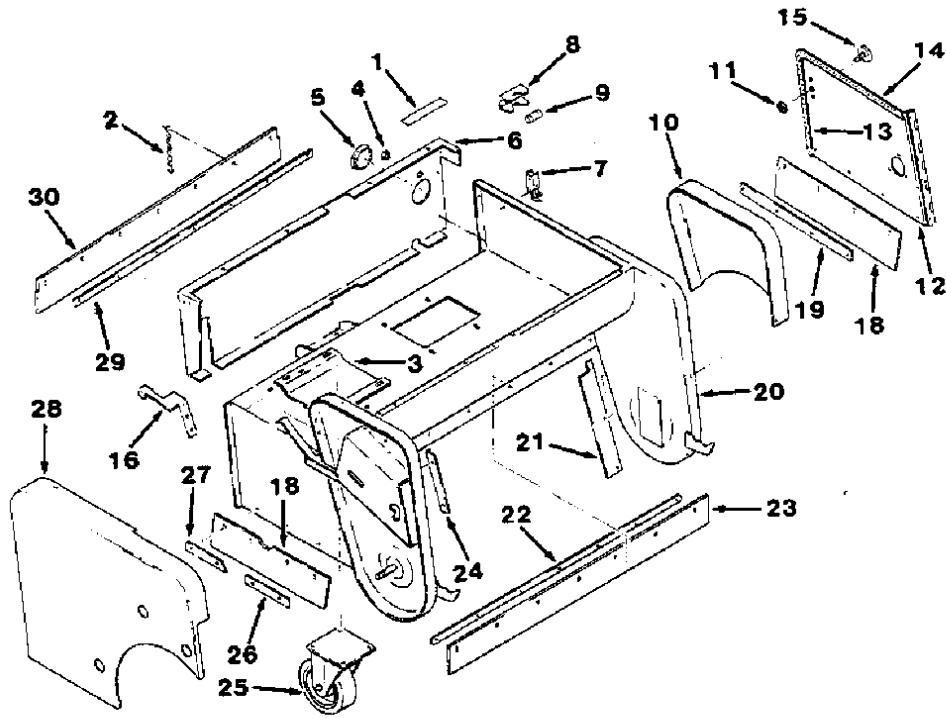

FIG. 3 - MAIN FRAME GROUP

02233

KEY	TENNANT® PART NO.	MACHINE SERIAL NUMBER	DESCRIPTION	QTY.
1	29885	(-)	DECAL, Time delay fuse	1
2	29704	(-)	CHAIN	1
3	29123	(-)	MOUNT, Motor	1
4	47178-1	(-)	PLUGBUTTON	1
5	47178-6	(-)	PLUGBUTTON	1
6	32914	(-)	PLATE, Back	1
7	29742	(-)	LATCH, Hinge	1
8	SK2534	(000000000-0000007568)	REPLACEMENT KIT, Fuseholder	1
8	32922	(0000007569-)	HOLDER, Fuse	1
9	04930	(-)	FUSE, 60 A	1
10	28088	(-)	SHROUD, Wheel, L.H.	1
11	26015	(-)	FASTENER	1
12	28904-1	(-)	DOOR ASSEMBLY	1
13	28277-2	(-)	SEAL, Foam	1
14	28277-1	(-)	SEAL, Foam	1
15	28164	(-)	FASTENER	1
16	28726	(-)	SHOE, Upper	1
17	09182-2	(000000000-xxxxxxxxxx)	STRIKE, Catch	1
18	28072	(-)	SKIRT, Side	2
19	28025	(-)	RETAINER	1
20	28801	(-)	FRAME, Main	1
21	28069	(-)	SEAL	1
22	28437	(-)	RETAINER, Top pan seal	1
23	28068	(-)	SKIRT, Top pan	1
24	28139	(-)	SEAL	1
25	47728A	(-)	CASTER	1
	47728-1	(-)	TIRE	1
	SK2167	(-)	BEARING, Caster	1
26	28026	(-)	STRIP	1
27	28250	(-)	RETAINER, Rear skirt, R.H.	1
28	28648	(-)	SHROUD, Wheel, R.H.	1
29	28067	(-)	STRIP	1
30	28071	(-)	SKIRT, Rear	1

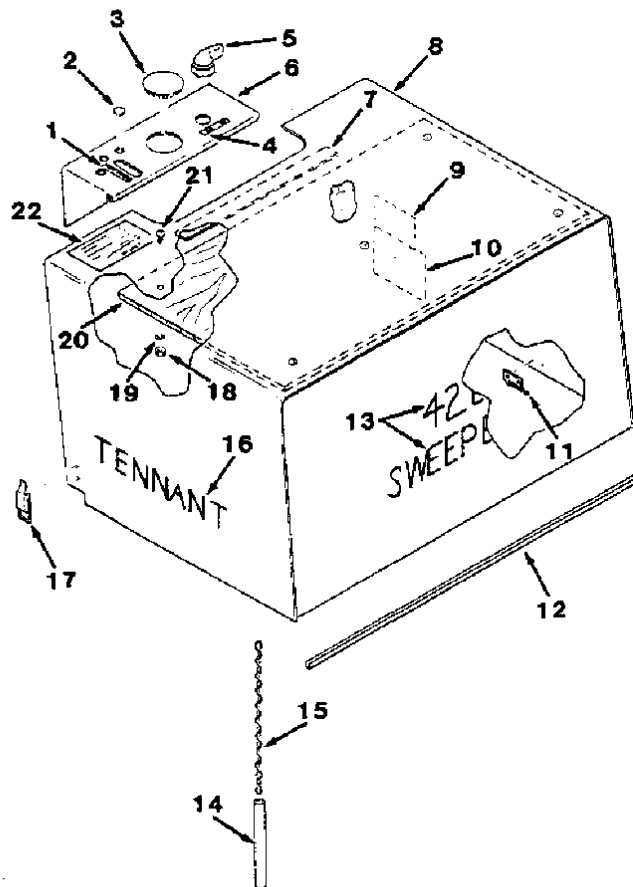

FIG. 4 - BATTERY COVER ASSEMBLY

02225

KEY	TENNANT® PART NO.	MACHINE SERIAL NUMBER	DESCRIPTION	QTY.
	28772	(-)	PANEL ASSEMBLY, Instrument	1
1	29295	(-)	DECAL, Brush lift	1
2	56992	(-)	PLUGBUTTON	1
3	47178-8	(-)	PLUGBUTTON	1
4	29169	(-)	DECAL, On-off	1
5	47132	(-)	SWITCH	1
6	28744	(-)	BRACKET, Instrument	1
	28750-1	(-)	COVER ASSEMBLY	1
7	29731	(-)	BAR	1
8	28750	(-)	COVER	1
9	19820	(-)	DECAL, Battery requirements	1
10	29298	(-)	DECAL, Wiring diagram	1
11	29743	(-)	STRIKE	2
12	29297	(-)	MOLDING, Rigid	1
13	28210	(-)	DECAL, 42E, White letters	1
14	27363	(-)	SLEEVE	1
15	29741	(-)	CHAIN	1
16	28207	(-)	DECAL, TENNANT®, White letters	2
17	23709	(-)	CATCH	1
18	29855	(-)	NUT	5
19	29854	(-)	WASHER	5
20	28748	(-)	LINER, Battery cover	1
21	29853	(-)	SCREW	5
22	29279	(-)	DECAL, Caution-battery charger	1

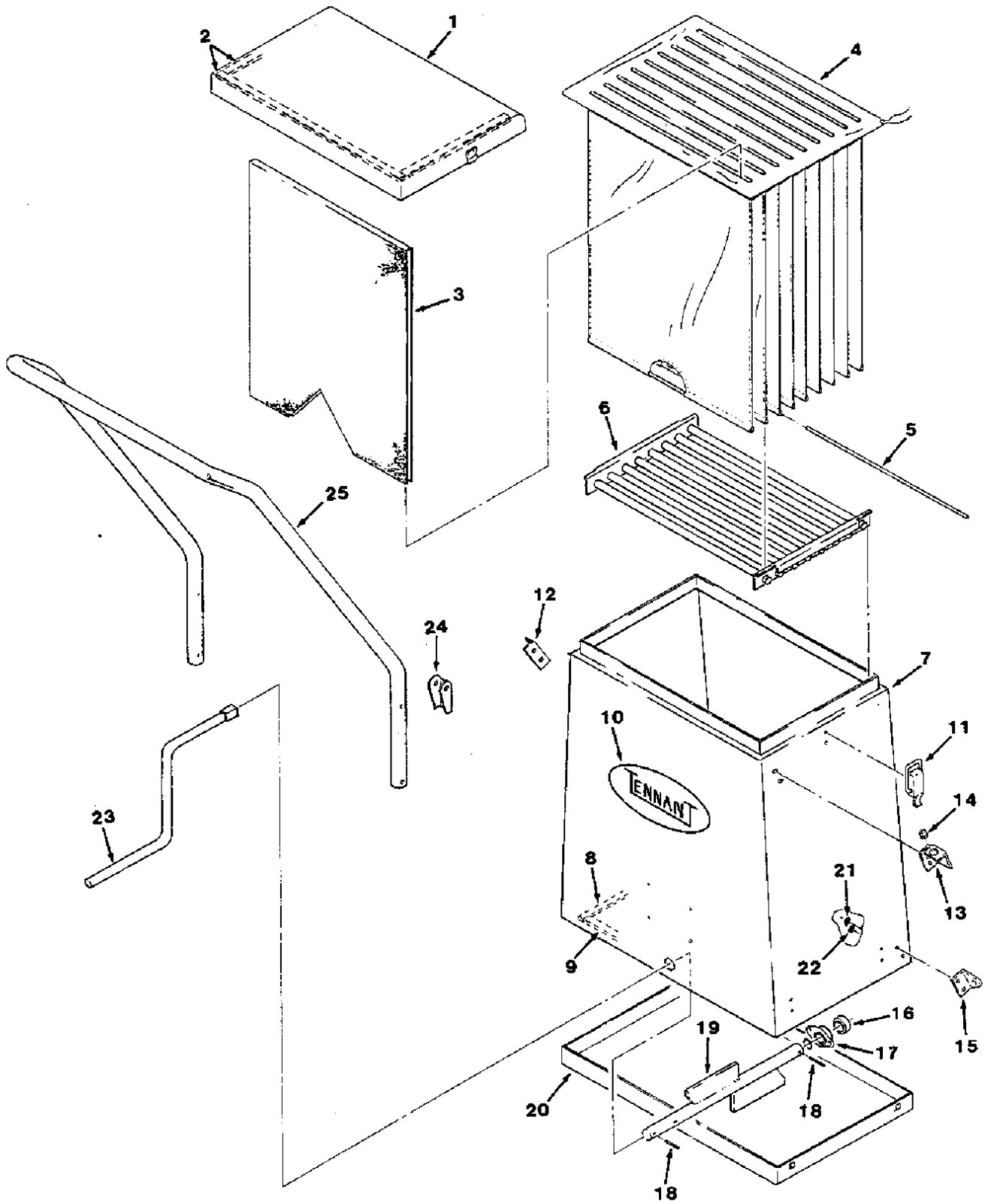

FIG. 5 - FILTER BOX ASSEMBLY

FIG. 5 - FILTER BOX ASSEMBLY

02226

KEY	TENNANT® PART NO.	MACHINE SERIAL NUMBER	DESCRIPTION	QTY.
	29151	(-)	FILTER BOX ASSEMBLY	1
1	28934A-1	(-)	COVER ASSEMBLY, Filter box	1
2	28935	(-)	SEAL KIT	1
3	47800	(-)	SEPARATOR	5
4	28810	(-)	FILTER	1
5	28823	(-)	WEIGHT, Bag	9
6	29208	(-)	RACK ASSEMBLY, Bag	1
7	29150-1	(-)	FILTER BOX ASSEMBLY	1
8	28950-1	(-)	SEAL, Foam	2
9	28950-2	(-)	SEAL, Foam	2
10	28613-2	(-)	DECAL, TENNANT® Oval	1
11	23709	(-)	CATCH	6
12	28911	(-)	BRACKET	2
13	30096	(-)	GUIDE, Clutch rod	1
14	29912	(-)	BUSHING, Flange	1
15	28912	(-)	BRACKET	2
16	28132	(-)	COLLAR, Bearing	2
17	28156	(-)	BEARING, Flange	2
18	22134	(-)	PIN, Roll	2
19	28913	(-)	SHAKER	1
20	29221	(-)	PAN, Dust	1
21	29570	(-)	WASHER	6
22	29570-1	(-)	WASHER	2
23	27021	(-)	HANDLE, Shaker	1
24	29092	(-)	PIVOT	2
25	31007	(-)	HANDLE ASSEMBLY	1

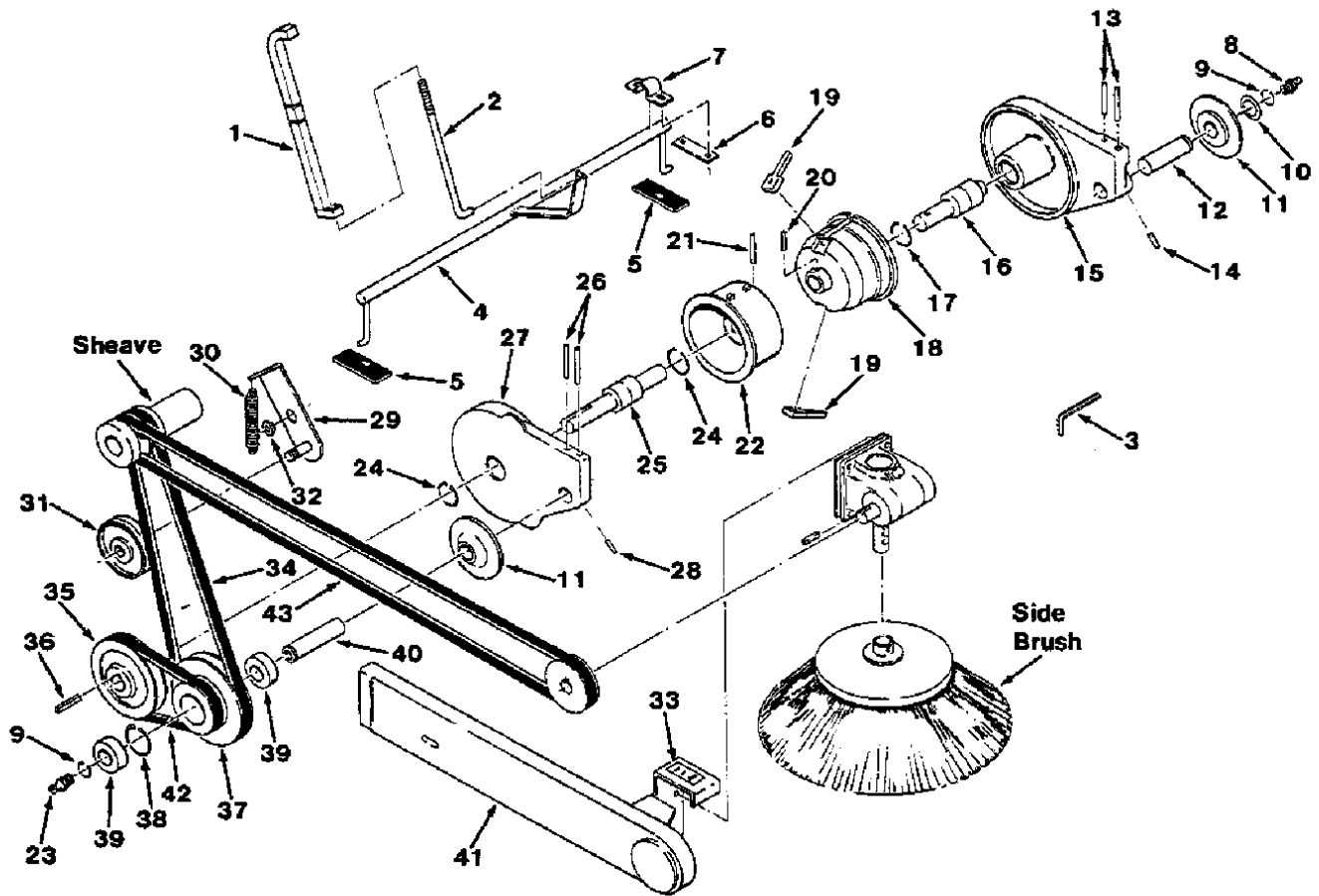

FIG. 6 - BRUSH DRIVE GROUP

FIG. 6 - BRUSH DRIVE GROUP

02228

KEY	TENNANT® PART NO.	MACHINE SERIAL NUMBER	DESCRIPTION	QTY.
1	28742	(-)	HANDLE	1
2	28711	(-)	ROD, L	1
3	02983	(-)	WRENCH, Allen	1
4	28886	(-)	SHAFT, Brush lift	1
5	29005	(-)	SEAL	2
6	28066	(-)	STRIP	3
7	28074	(-)	CLAMP	3
8	07259	(-)	FITTING, Grease	2
9	18136	(-)	RING, Retaining	2
10	28862	(-)	WASHER, Thrust	1
11	28847-1	(-)	BUSHING	1
12	28850A	(-)	SHAFT, Short	1
13	20050	(-)	PIN, Roll	2
14	26103	(-)	PIN, Roll	1
15	28841	(-)	ARM	1
16	28868	(-)	BEARING AND SHAFT ASSEMBLY	1
17	23217	(-)	RING, Retaining	1
18	28844	(-)	PLUG, Brush idler	1
19	28852	(-)	FINGER	2
20	26239	(-)	PIN, Roll	1
	28974A	(-)	ARM AND PLUG ASSEMBLY, Brush	1
21	26239	(-)	PIN, Roll	1
22	28976	(-)	PLUG AND PIN ASSEMBLY, Drive	1
23	07259	(-)	FITTING, Grease	1
24	23217	(-)	RING, Retaining	2
25	28867	(-)	BEARING AND SHAFT ASSEMBLY	1
26	20050	(-)	PIN, Roll	2
27	28840	(-)	ARM	1
28	26103	(-)	PIN, Roll	1
	29267	(-)	ARM AND SHEAVE ASSEMBLY, idler	1
29	28241	(-)	ARM AND SHAFT ASSEMBLY	1
30	26212	(-)	SPRING, Tension	1
31	28223	(-)	PULLEY ASSEMBLY	1
32	28008	(-)	RETAINER	1
33	29976	(-)	DECAL, Brush Lift	1
34	28167	(-)	V-BELT, Short	1
35	28979	(-)	SHEAVE ASSEMBLY, Adjustable	1
	18276	(-)	PIN, Dowel	2
	28387	(-)	SPRING, Tension	3
	28388	(-)	RETAINER	2
36	00911	(-)	KEY, Square	1
37	29266	(-)	SHEAVE ASSEMBLY, Brush	1
38	01513	(-)	RING, Retaining	1
39	28010	(-)	BEARING, Ball	2
40	SK0510	(0000000000-0000044834)	SHEAVE KIT	1
40	28849-1	(0000044835-	SHAFT, Long	1
41	28118-1A	(-)	ARM	1
42	28168	(-)	V-BELT	1
43	28122	(0000000000-0000009066)	V-BELT	1
43	32413	(0000009067-	V-BELT	1

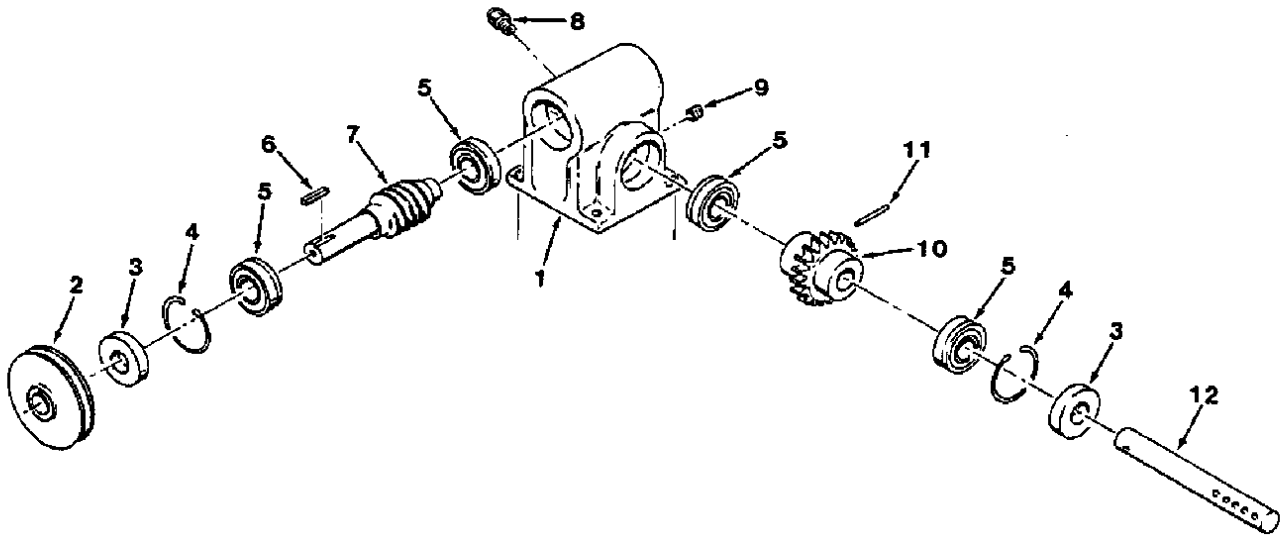

FIG. 7 - SIDE BRUSH SPEED REDUCER, SWEEPER

02227

KEY	TENNANT® PART NO.	MACHINE SERIAL NUMBER	DESCRIPTION	QTY.
1	28119-1	(-)	REDUCER ASSEMBLY, Gear	1
2	28121	(-)	SHEAVE	1
3	28084	(-)	SEAL, Oil	2
4	01513	(-)	RING, Retaining	2
5	28011	(-)	BEARING, Ball	4
6	00911	(-)	KEY, Square	1
7	28194	(-)	WORM	1
8	07316-15	(-)	BREATHER	1
9	02246	(-)	FITTING, Plug	1
10	28195	(-)	GEAR	1
11	28144	(-)	PIN, Roll	1
12	28041	(-)	SHAFT, Reducer	1

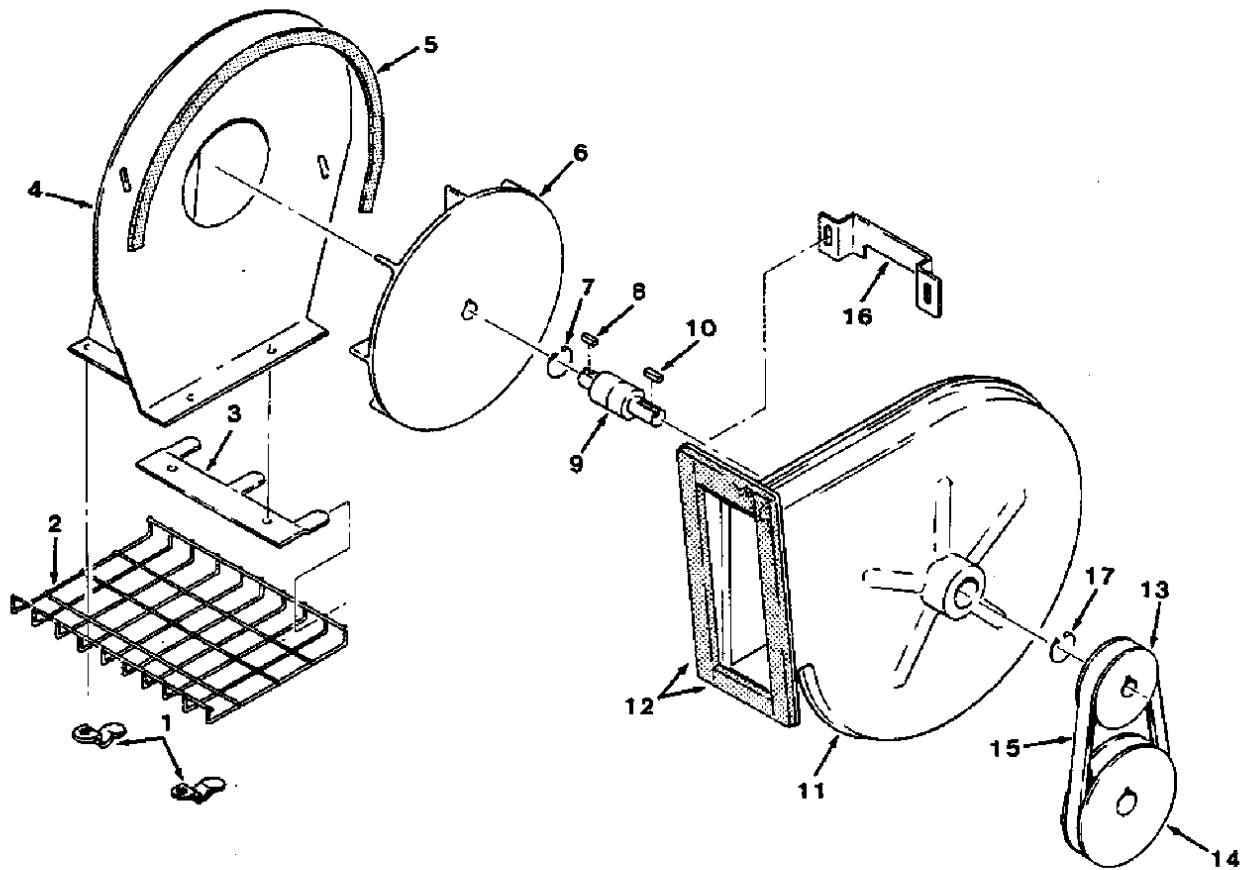

FIG. 8 - VACUUM FAN ASSEMBLY

02229

KEY	TENNANT® PART NO.	MACHINE SERIAL NUMBER	DESCRIPTION	QTY.
1	28217	(-)	CLIP, Fan screen	2
2	28877	(-)	SCREEN	1
3	29245	(-)	RETAINER, Screen, front	1
	29850	(-)	DUCT AND HOUSING ASSEMBLY, Fan	1
4	29129-1	(-)	DUCT AND SUPPORT ASSEMBLY, Fan	1
	28938-1	(-)	SEAL, Felt	1
	31068	(-)	HOUSING ASSEMBLY, Fan	1
6	23444	(-)	IMPELLER	1
7	23217	(-)	RING, Retaining	2
8	00911	(-)	KEY	1
9	28939	(-)	BEARING AND SHAFT	1
10	00954	(-)	KEY, Square	1
11	29121-1	(-)	IMPELLER, Housing assembly	1
12	28988	(-)	SEAL KIT	1
13	29120	(-)	SHEAVE	1
14	29126	(-)	SHEAVE	1
15	22426	(-)	V-BELT	1
16	28658	(-)	BRACKET, Clamp	1

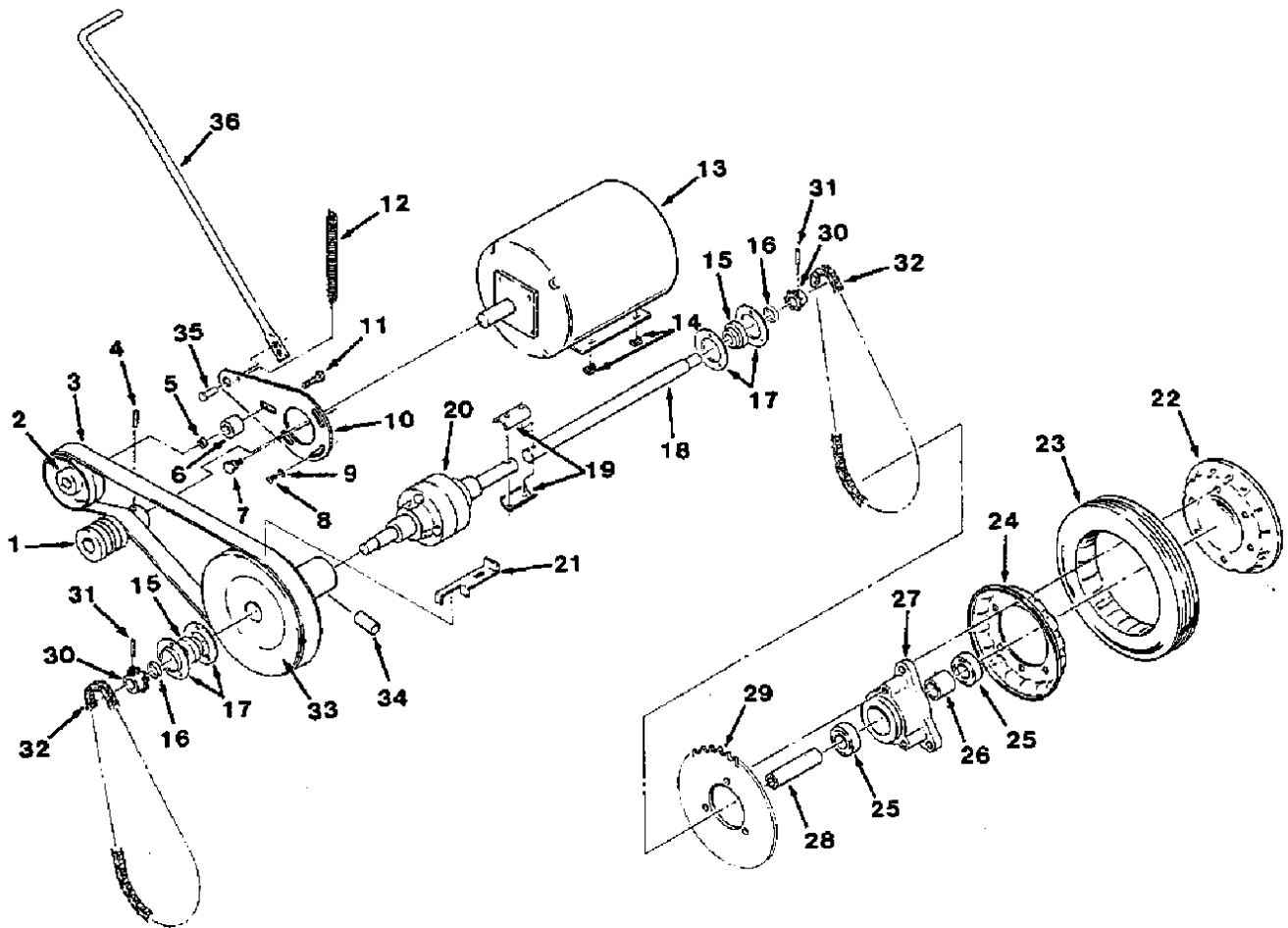

FIG. 9 - DRIVE GROUP

FIG. 9 - DRIVE GROUP

02230

KEY	TENNANT® PART NO.	MACHINE SERIAL NUMBER	DESCRIPTION	QTY.
1	28059-2	(-)	SHEAVE	1
2	28225	(-)	PULLEY	1
3	28141	(-)	BELT, Flat	1
4	28290	(-)	PIN, Roll	1
5	29091	(-)	SLEEVE	1
6	29089	(-)	BOSS, Spacer	1
7	29087	(-)	SCREW	1
8	28614	(-)	SCREW	2
9	28008	(-)	RETAINER	2
10	29086	(-)	PLATE, Clutch	1
11	32972	(-)	BOLT	1
12	01053	(-)	SPRING, Tension	1
13	29125	(0000000000-0000008101)	MOTOR, Electric, 24 VDC	1
13	32992	(0000008102-	MOTOR, Electric, 24 VDC	1
14	29124	(-)	NUT	4
15	23624	(-)	BEARING AND COLLAR	2
16	28679	(-)	SPACER	2
17	23624	(0000000000-0000048426)	BEARING	4
17	51137	(0000048427-	FLANGE, Bearing	4
18	28860	(0000000000-0000048426)	SHAFT, Counter	1
18	29877	(0000048427-	SHAFT, Counter	1
19	28861	(-)	COUPLING	1
20	28859	(0000000000-0000048426)	DIFFERENTIAL	1
20	29873	(0000048427-	DIFFERENTIAL AND SHAFT	1
21	29760	(-)	GUIDE, Belt	1
	28061	(-)	WHEEL AND TIRE ASSEMBLY	2
22	28128	(-)	WHEEL, Half, outside	1
23	28546	(-)	TIRE	1
24	28211	(-)	WHEEL, Half, inside	1
	28805	(-)	HUB ASSEMBLY	2
25	28010	(-)	BEARING	2
26	28014A	(-)	SLEEVE	1
27	28842	(-)	HUB, Wheel	1
28	28226	(-)	SLEEVE	1
29	28865	(-)	SPROCKET	1
30	29144	(-)	SPROCKET	2
31	26103	(-)	PIN, Roll	2
32	33685	(-)	CHAIN	2
	28272	(-)	LINK	1
33	28897	(0000000000-0000048426)	PULLEY	1
33	30017-1	(0000048427-	PULLEY ASSEMBLY	1
	29876	(-)	BUSHING	1
34	07259	(-)	FITTING, Grease	1
35	26341	(-)	PIN, Clevis	1
36	29898	(-)	HANDLE, Clutch	1

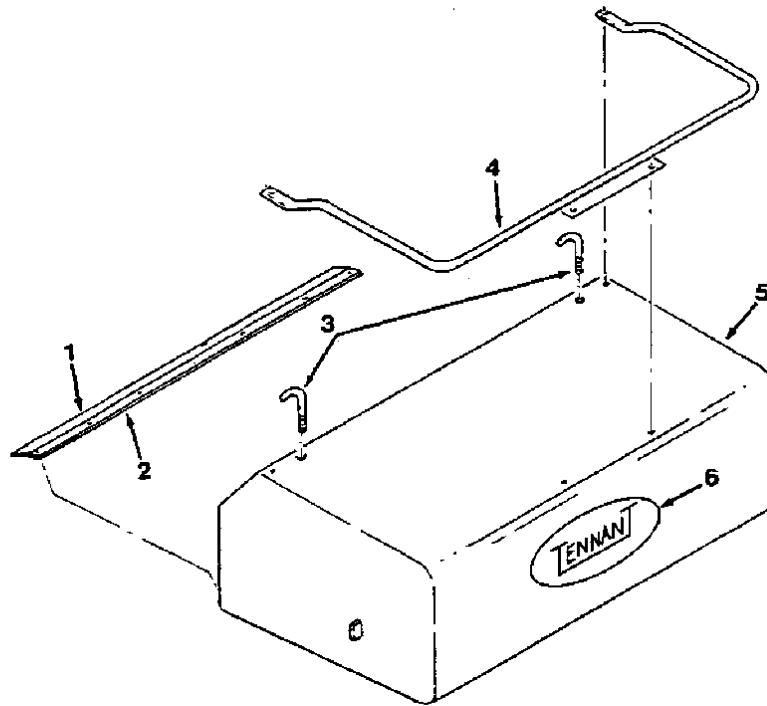

FIG. 10 - HOPPER ASSEMBLY

02231

KEY	TENNANT® PART NO.	MACHINE SERIAL NUMBER	DESCRIPTION	QTY.
	28969-1	(-)	HOPPER ASSEMBLY	1
1	28081	(-)	LIP	1
2	31025	(-)	RETAINER, Hopper	1
3	28206	(-)	HANGAR	2
4	28915	(-)	HANDLE ASSEMBLY	1
5	28951-1	(-)	HOPPER	1
6	28613-2	(-)	DECAL, TENNANT® Oval, black letters	1

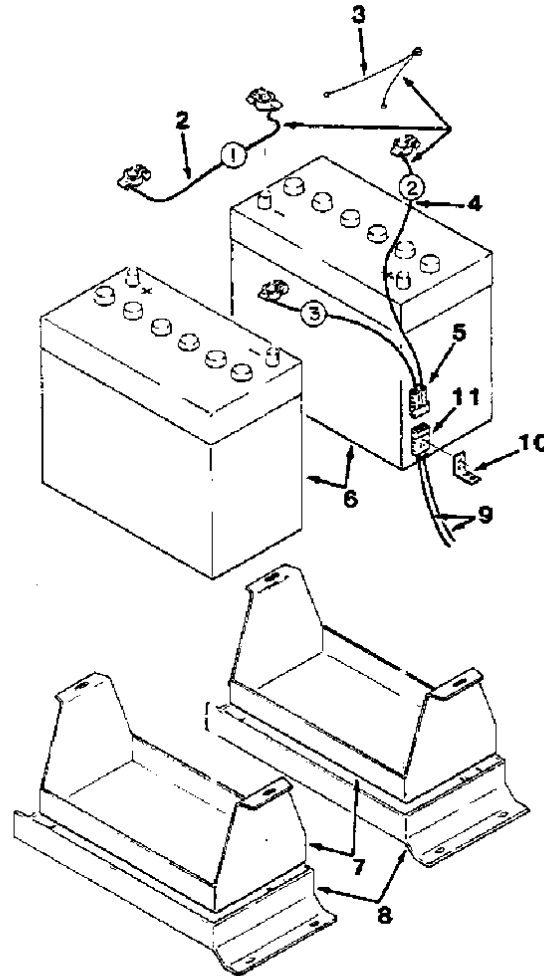
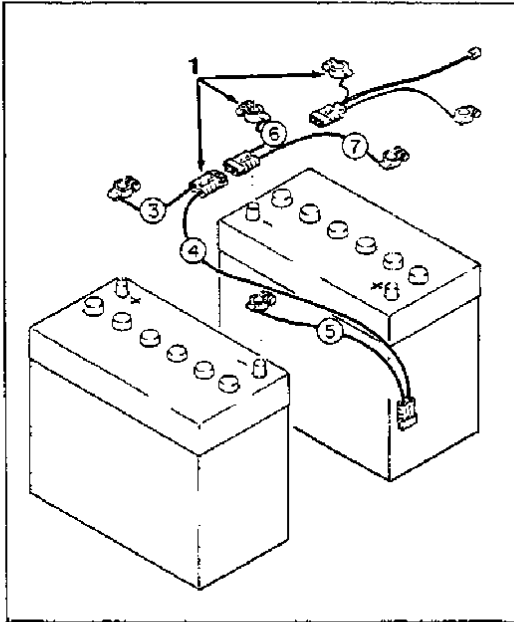

FIG. 11 - BATTERY GROUP, WET

02232

KEY	TENNANT® PART NO.	MACHINE SERIAL NUMBER	DESCRIPTION	QTY.
	31017-1	(-)	BATTERY KIT, Wet	1
1	50483	(-)	WIRE KIT, Battery	1
2	50480	(-)	CABLE ASSEMBLY, Battery	1
3	50482	(-)	WIRE ASSEMBLY, Shaker	1
4	50481	(-)	CABLE ASSEMBLY, Battery	1
5	24881	(-)	CONNECTOR	1
6	19591	(-)	BATTERY, 12 V	2
7	29110	(-)	TRAY, Battery	2
8	29113	(-)	BRACKET	2
9	29214	(-)	PLUG AND WIRE ASSEMBLY	1
10	29139	(-)	BRACKET	1
11	24881	(-)	CONNECTOR	1



SECTION 6 HD MODEL PARTS

CONTENTS

	Page
Ordering Repair Parts.....	6-1
Fig. 1 - Main Frame Group, HD	6-2
Fig. 2 - Battery Cover Assembly, HD.....	6-3
Fig. 3 - Filter Box Assembly, HD.....	6-4
Fig. 4 - Side Brush Guard Group, HD	6-6
Fig. 5 - Hopper Assembly, HD.....	6-7

NOTE: Section 6, HD Model Parts, lists every repair part for an HD Model machine.

ORDERING REPAIR PARTS

To avoid errors or delays in filling parts orders, please furnish all of the following information.

1. Always specify the machine model number and the machine serial number shown on the machine data plate.

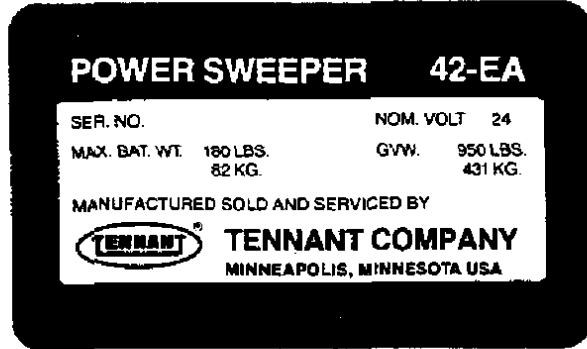

2. Give the part number, description, and the quantity needed of each item on the order. Do not order by reference number or the figure number of the illustrated parts.
3. Indented items indicate parts of assemblies. Standard hardware is furnished only when part of a purchased assembly. Please order hardware from a local hardware supplier.
4. If the old part cannot be identified, send it to us with the quantity needed specified on the order.
5. State definite shipping instructions to include the shipping address and/or the billing address if there is a difference. Any claim for loss or damage to a shipment in transit should be filed promptly against the transportation company making the delivery. Shipments will be complete unless the packing list or order acknowledgement indicate items back ordered.

If parts received are suspected to be incorrect or defective, please write, wire, or phone the Tennant Company representative from whom you ordered the part. They will give authorization for return and/or handle replacement shipments when required.

SI (INTERNATIONAL SYSTEM) UNITS OF MEASURE

Metric equivalents have been included, where applicable, throughout this parts catalog.

BOLT AND CAP SCREW STRENGTH IDENTIFICATION

Bolts and cap screws required to have high-strength qualities equivalent to SAE Grade 8 are identified throughout this catalog by the description GR 8. Unless identified by this description, all standard bolts and cap screws are SAE Grade 5.

SERIAL NUMBER INFORMATION EXPLANATION

Serial number information is listed parenthetically to show on which machines each part can be used. These listings are explained by the following examples:

(-) The part can be used on all machines.

(0000001234-) The part can be used on all machines beginning with the serial number listed.

(0000000000-0000001234) The part can be used on all machines up to and including serial number listed.

(0000001234-0000005678) The part can be used on all machines between and including the serial numbers listed.

Where XXXXX's are listed in place of a serial number, it indicates a serial number change was made but the exact serial number had not been established when the catalog went to press.

(Specifications and design subject to change without notice.)

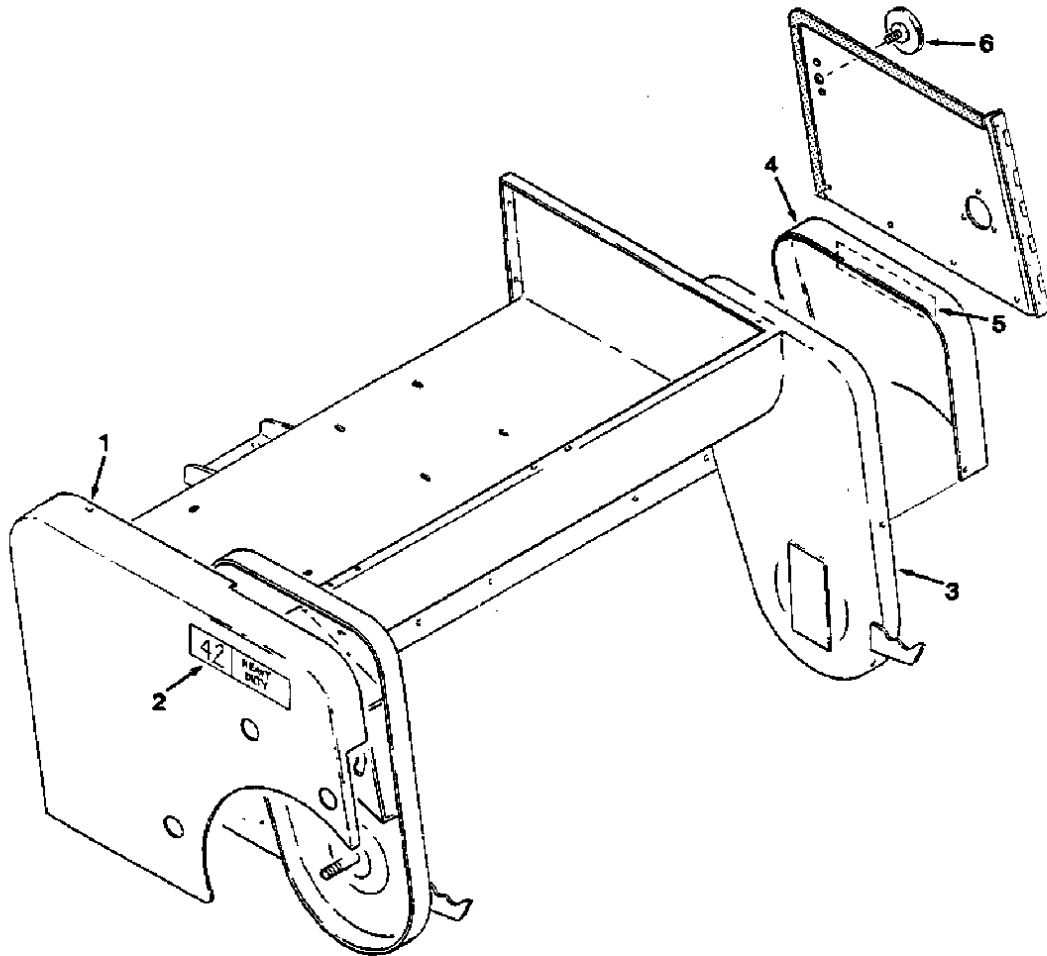

FIG. 1 - MAIN FRAME GROUP, HD

02237

KEY	TENNANT® PART NO.	MACHINE SERIAL NUMBER	DESCRIPTION	QTY.
1	28648-2	(-)	SHROUD ASSEMBLY, R. H.	1
2	31016	(-)	DECAL, 42HD	1
3	28801	(-)	FRAME	1
4	28088-2	(-)	SHROUD ASSEMBLY, Wheel, L. H.	1
5	31016	(-)	DECAL, 42HD	1
6	29982	(-)	KNOB	1

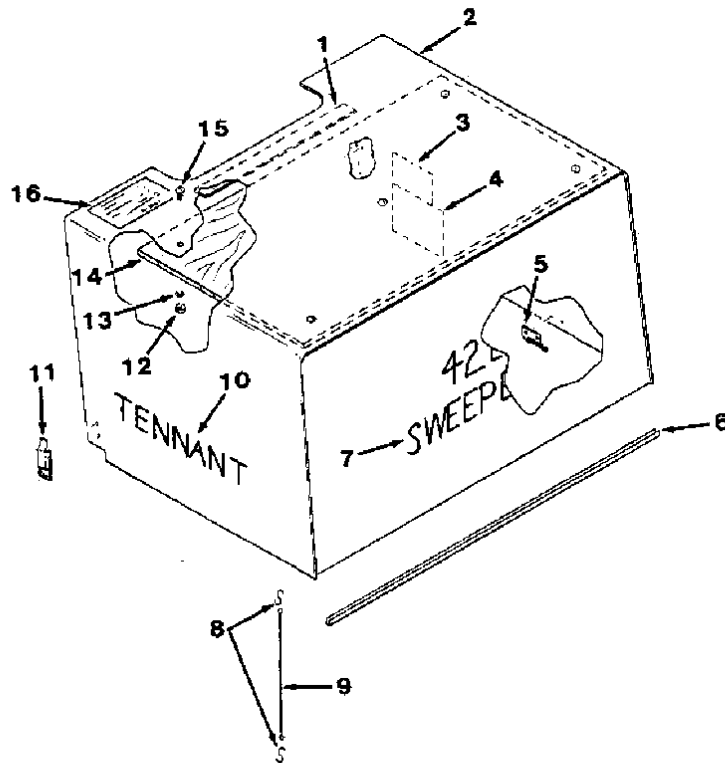

FIG. 2 - BATTERY COVER ASSEMBLY, HD

02236

KEY	TENNANT® PART NO.	MACHINE SERIAL NUMBER	DESCRIPTION	QTY.
	28750-2	(-)	COVER ASSEMBLY, Battery, HD	1
1	29731	(-)	FELT	1
2	28750	(-)	COVER	1
3	19820	(-)	DECAL, Battery requirements	1
4	50731	(-)	DECAL, Wiring diagram	1
5	29743	(-)	STRIKE, Clamp	2
6	62595-21	(-)	MOLDING, Rigid	1
7	28210-1	(-)	DECAL, 42EHD	1
8	43363	(-)	HOOK, S	2
9	01749	(-)	CABLE	1
10	28207	(-)	DECAL, TENNANT®	2
11	23709	(-)	CATCH, Draw Pull	1
12	29855	(-)	NUT, Hex	5
13	29854	(-)	WASHER	5
14	28748	(-)	LINER, Battery Cover	1
15	29853	(-)	SCREW, Nylon	5
16	29279	(-)	DECAL, Caution-Battery charger	1

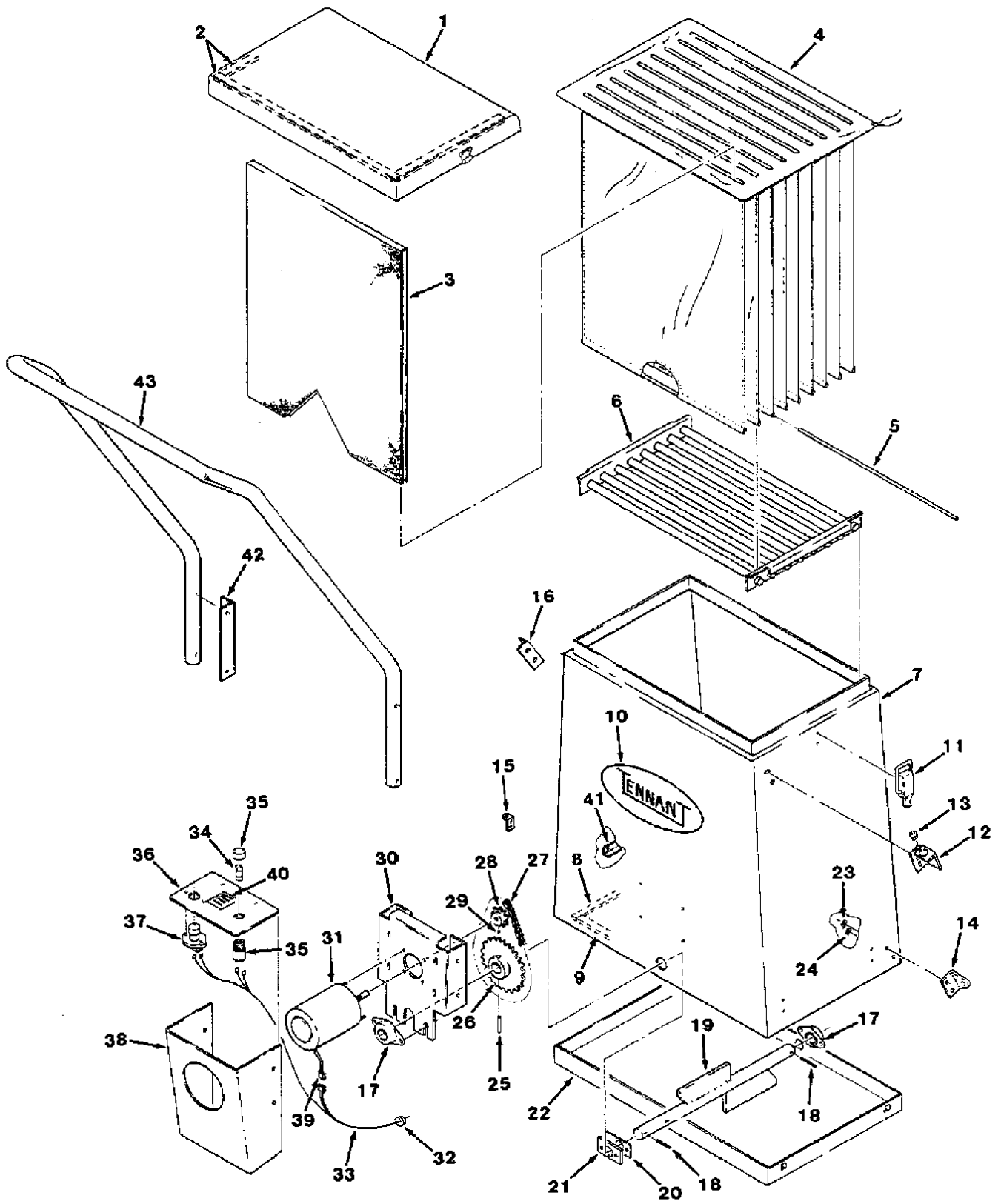

FIG. 3 - FILTER BOX ASSEMBLY, HD

FIG. 3 - FILTER BOX ASSEMBLY, HD

02234

KEY	TENNANT® PART NO.	MACHINE SERIAL NUMBER	DESCRIPTION	QTY.
	31003	(-)	FILTER BOX ASSEMBLY, HD	1
1	28934A-1	(-)	COVER ASSEMBLY, Filter box	1
2	28935	(-)	SEAL KIT	1
3	47800	(-)	SEPARATOR, Bag	5
4	28810	(-)	FILTER	1
5	29903	(-)	WEIGHT, Bag	9
6	29208	(-)	RACK ASSEMBLY, Bag	1
7	31004	(-)	FILTER BOX ASSEMBLY	1
8	28950-1	(-)	SEAL, Foam	2
9	28950-2	(-)	SEAL, Foam	2
10	28613-2	(-)	DECAL, TENNANT® Oval	1
11	23709	(-)	CATCH	6
12	29911	(-)	BRACE, Handle	1
13	29991	(-)	BUSHING, Flange	1
14	29910	(-)	BRACE, Handle, R. H.	1
15	29910-1	(-)	BRACE, Handle, L. H.	1
16	28912	(-)	BRACKET	1
17	26663	(-)	BEARING, Flange	2
18	28290	(-)	PIN, Roll	2
19	30000	(-)	SHAKER	1
20	29933	(-)	PLATE, Seal	1
21	29740	(-)	SEAL, Shaft	1
22	29221	(-)	PAN, Dust	1
23	29570	(-)	WASHER	6
24	29570-1	(-)	WASHER	2
25	23146	(-)	PIN, Roll	1
26	23628	(-)	SPROCKET	1
27	33719	(-)	CHAIN ASSEMBLY	1
	14799	(-)	LINK	1
28	23626	(-)	SPROCKET	1
29	39327	(-)	SCREW	1
30	29994	(-)	BRACKET, Motor mounting	1
31	27321	(-)	MOTOR, Electric	1
32	10632-16	(-)	GROMMET	1
33	45596	(-)	WIRE KIT, Shaker motor	1
34	07423	(-)	FUSE, 15A	1
35	07422	(-)	FUSE HOLDER	1
36	29995	(-)	PLATE, Switch	1
37	44078	(-)	SWITCH	1
38	29996	(-)	SHROUD	1
39	29978	(-)	LEAD, Shaker	1
40	36309	(-)	DECAL, Filter shaker	1
41	29919	(-)	COVER, Wire	1
42	29906-1	(-)	BRACE, Handle, L. H.	1
43	31007	(-)	HANDLE ASSEMBLY	1

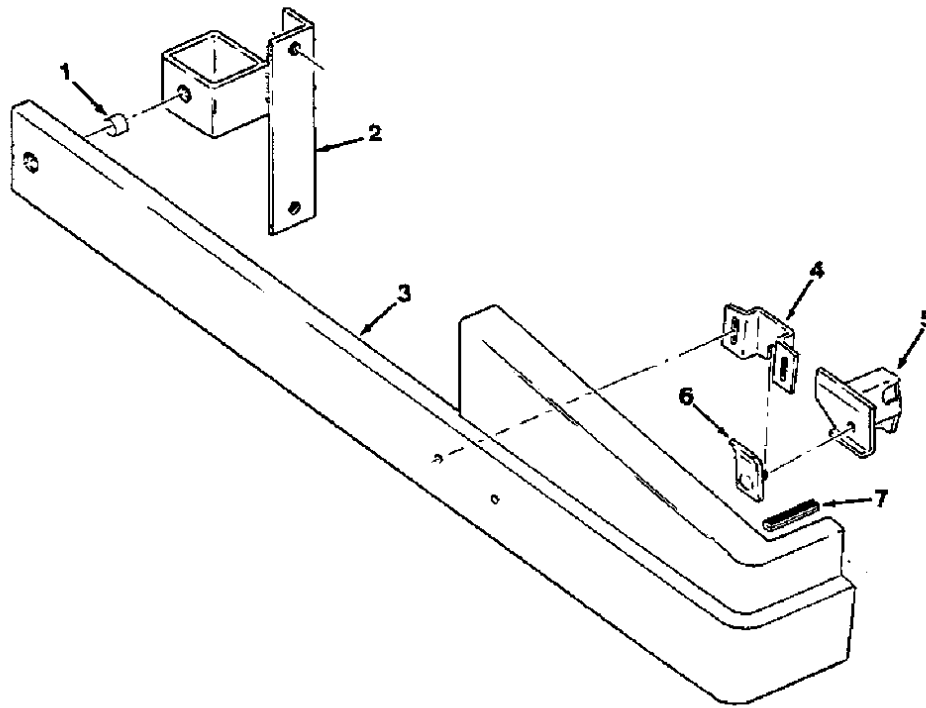

FIG. 4 - SIDE BRUSH GUARD GROUP, HD

02235

KEY	TENNANT® PART NO.	MACHINE SERIAL NUMBER	DESCRIPTION	QTY.
1	29894	(-)	BUSHING, Sleeve	1
2	29904	(-)	BRACE	1
3	29890	(-)	BUMPER	1
4	29880	(-)	LATCH	1
5	29918	(-)	BRACKET	1
6	29884	(-)	KEEPER	1
7	62595-18	(-)	MOLDING, Rigid	1

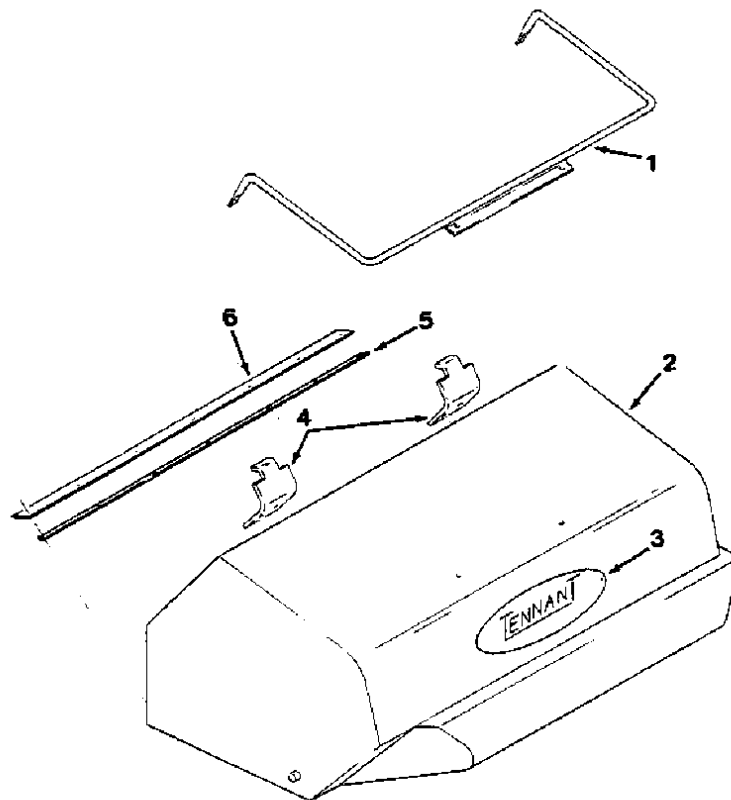

FIG. 5 - HOPPER ASSEMBLY, HD

02238

KEY	TENNANT® PART NO.	MACHINE SERIAL NUMBER	DESCRIPTION	QTY.
	29902	(-)	HOPPER ASSEMBLY	1
1	29896	(-)	HANDLE, Hopper	1
2	29969	(-)	HOPPER	1
3	28613-2	(-)	DECAL, TENNANT® Oval	1
4	29998	(-)	BRACKET	2
5	28081	(-)	LIP ASSEMBLY, Pan	1
6	31025	(-)	RETAINER	1



SECTION 7 EE MODEL PARTS

CONTENTS

	Page
Ordering Repair Parts.....	7-1
Fig. 1 - EE Group	7-2
Fig. 2 - HD-EE Group.....	7-2

NOTE: Section 7, EE Model Parts, lists every repair part for an EE Model machine.

ORDERING REPAIR PARTS

To avoid errors or delays in filling parts orders, please furnish all of the following information.

1. Always specify the machine model number and the machine serial number shown on the machine data plate.

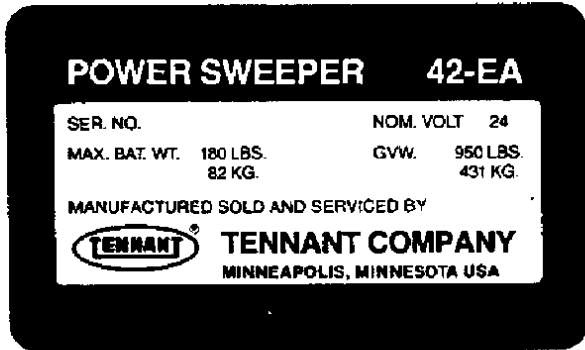

2. Give the part number, description, and the quantity needed of each item on the order. Do not order by reference number or the figure number of the illustrated parts.
3. Indented items indicate parts of assemblies. Standard hardware is furnished only when part of a purchased assembly. Please order hardware from a local hardware supplier.
4. If the old part cannot be identified, send it to us with the quantity needed specified on the order.
5. State definite shipping instructions to include the shipping address and/or the billing address if there is a difference. Any claim for loss or damage to a shipment in transit should be filed promptly against the transportation company making the delivery. Shipments will be complete unless the packing list or order acknowledgement indicate items back ordered.

If parts received are suspected to be incorrect or defective, please write, wire, or phone the Tennant Company representative from whom you ordered the part. They will give authorization for return and/or handle replacement shipments when required.

SI (INTERNATIONAL SYSTEM) UNITS OF MEASURE

Metric equivalents have been included, where applicable, throughout this parts catalog.

BOLT AND CAP SCREW STRENGTH IDENTIFICATION

Bolts and cap screws required to have high-strength qualities equivalent to SAE Grade 8 are identified throughout this catalog by the description GR 8. Unless identified by this description, all standard bolts and cap screws are SAE Grade 5.

SERIAL NUMBER INFORMATION EXPLANATION

Serial number information is listed parenthetically to show on which machines each part can be used. These listings are explained by the following examples:

() The part can be used on all machines.

(0000001234-) The part can be used on all machines beginning with the serial number listed.

(0000000000-0000001234) The part can be used on all machines up to and including serial number listed.

(0000001234-0000005678) The part can be used on all machines between and including the serial numbers listed.

Where XXXXX's are listed in place of a serial number, it indicates a serial number change was made but the exact serial number had not been established when the catalog went to press.

(Specifications and design subject to change without notice.)

FIG. 1 - EE GROUP

02244

KEY	TENNANT® PART NO.	MACHINE SERIAL NUMBER	DESCRIPTION	QTY.
	29238	(-)	BRACKET	1
	29239	(-)	BRACE	1
	48671	(-)	STIFFENER, Frame	1
	29206	(-)	FUSE BOX	1
	27223	(-)	STRAIN RELIEF	2
	10125	(-)	NUT, Lock	2
	29244	(-)	PLATE, Filler	1
	29214	(-)	PLUG WIRE ASSEMBLY	1
	49287	(-)	CLAMP, Cable	1
	11438	(-)	STRIKE	1

FIG. 2 - HD-EE GROUP

02245

KEY	TENNANT® PART NO.	MACHINE SERIAL NUMBER	DESCRIPTION	QTY.
	SK2533	(0000000000-0000007423)	REPLACEMENT KIT, Fuse box	1
	39224	(0000007424-	FUSE BOX	1
	39215	(-)	PLATE	1
	29999	(-)	WIRE ASSEMBLY, Shaker	1
	27352	(-)	WIRE ASSEMBLY, Fuse	1
	27349	(-)	FUSE BLOCK	1
	31051	(-)	FUSE, 15 A	1
	39553	(-)	FLANGE, Door seal	3
	26395-1	(-)	CLAMP, Cable	1
	01738	(-)	MOTOR, Electric	1
	01739	(-)	BRUSH KIT	1
	01740	(-)	SPRINGS, Brush	4
	29126	(-)	SHEAVE	1
	29214	(-)	PLUG AND WIRE ASSEMBLY	1
	24881	(-)	CONNECTOR	1
	29139	(-)	BRACKET	1

SECTION 8 ACCESSORIES

CONTENTS

	Page
Ordering Repair Parts.....	8-1
Fig. 1 - Battery Charger, 60 HZ	8-2
Fig. 2 - Battery Charger, 50 HZ	8-2
Fig. 3 - Dual Tire Kit.....	8-3
Fig. 4 - Brake Kit.....	8-3
Fig. 5 - Battery Charger Kit	8-4
Fig. 6 - Battery Charger Kit	8-4
Fig. 7 - Battery Charger Kit, 60 HZ	8-4
Fig. 8 - Battery Charger Group, 60 HZ, EE.....	8-5
Fig. 9 - Battery Charger Timer, 60HZ.....	8-5
Fig. 10 - Battery Charger Timer, 50HZ.....	8-5
Fig. 11 - Fire Extinguisher Kit	8-6
Fig. 12 - Hour Meter Kit	8-6
Fig. 13 - Battery Hoist Kit	8-7
Fig. 14 - Battery Kit, Dry, HD-EE	8-7
Fig. 15 - Prep for Scrub Kit	8-8
Fig. 16 - Vacuum Fan Group, Scrub.....	8-10
Fig. 17 - Rear Squeegee Group	8-12
Fig. 18 - Rear Squeegee Assembly	8-14
Fig. 19 - Side Brush and Squeegee Assemblies ...	8-16
Fig. 20 - Side Brush Speed Reducer, Scrub.....	8-17
Fig. 21 - Solution Control Group.....	8-18
Fig. 22 - Scrubber Cart Assembly	8-19
Fig. 23 - Scrub Tank Group.....	8-20

NOTE: Section 8, Accessories, lists repair parts included as part of the available accessories.

Home

Find...

Go To..



ORDERING REPAIR PARTS

To avoid errors or delays in filling parts orders, please furnish all of the following information.

1. Always specify the machine model number and the machine serial number shown on the machine data plate.

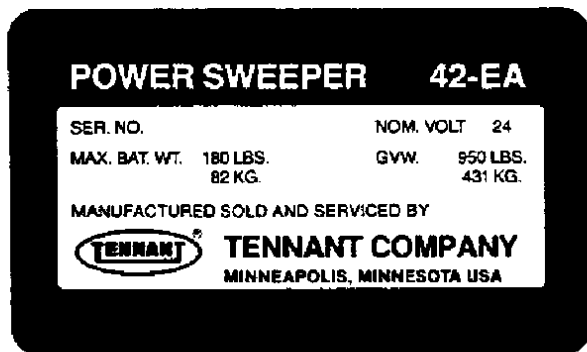

2. Give the part number, description, and the quantity needed of each item on the order. Do not order by reference number or the figure number of the illustrated parts.
3. Indented items indicate parts of assemblies. Standard hardware is furnished only when part of a purchased assembly. Please order hardware from a local hardware supplier.
4. If the old part cannot be identified, send it to us with the quantity needed specified on the order.
5. State definite shipping instructions to include the shipping address and/or the billing address if there is a difference. Any claim for loss or damage to a shipment in transit should be filed promptly against the transportation company making the delivery. Shipments will be complete unless the packing list or order acknowledgement indicate items back ordered.

If parts received are suspected to be incorrect or defective, please write, wire, or phone the Tennant Company representative from whom you ordered the part. They will give authorization for return and/or handle replacement shipments when required.

SI (INTERNATIONAL SYSTEM) UNITS OF MEASURE

Metric equivalents have been included, where applicable, throughout this parts catalog.

BOLT AND CAP SCREW STRENGTH IDENTIFICATION

Bolts and cap screws required to have high-strength qualities equivalent to SAE Grade 8 are identified throughout this catalog by the description GR 8. Unless identified by this description, all standard bolts and cap screws are SAE Grade 5.

SERIAL NUMBER INFORMATION EXPLANATION

Serial number information is listed parenthetically to show on which machines each part can be used. These listings are explained by the following examples:

() The part can be used on all machines.

(0000001234-) The part can be used on all machines beginning with the serial number listed.

(0000000000-0000001234) The part can be used on all machines up to and including serial number listed.

(0000001234-0000005678) The part can be used on all machines between and including the serial numbers listed.

Where XXXXX's are listed in place of a serial number, it indicates a serial number change was made but the exact serial number had not been established when the catalog went to press.

(Specifications and design subject to change without notice.)

FIG. 1 - BATTERY CHARGER, 60 HZ

02246

KEY	TENNANT® PART NO.	MACHINE SERIAL NUMBER	DESCRIPTION	QTY.
	31011	(-)	BATTERY CHARGER KIT, 60 HZ	1
	50708	(-)	CHARGER, Battery	1
	04126C	(-)	TERMINAL, Spade	1
	29688	(-)	AMMETER	1
	29199	(-)	PLATE, Battery tray	1
	29749	(-)	CORD ASSEMBLY	1
	29863	(-)	TUBE, Heatshrink	2
	31005	(-)	CLIP, Cord	2
	29888	(-)	WIRE KIT	1
	29232	(-)	STRAIN RELIEF	1
	29864	(-)	DECAL, Charger input	1

FIG. 2 - BATTERY CHARGER, 50 HZ

02247

KEY	TENNANT® PART NO.	MACHINE SERIAL NUMBER	DESCRIPTION	QTY.
	50721	(-)	BATTERY CHARGER KIT, 50 HZ	1
	50709	(-)	BATTERY CHARGER AND DECAL ASSEMBLY	1
	04126C	(-)	TERMINAL	1
	29688	(-)	AMMETER	1
	29199	(-)	PLATE, Battery tray	1
	50725	(-)	CORD ASSEMBLY	1
	29232	(-)	STRAIN RELIEF	1
	29863	(-)	TUBE, Heatshrink	1
	31005	(-)	CLIP, Cord	2
	29888	(-)	WIRE KIT	1
	50727	(-)	DECAL, Charger input	1

FIG. 3 - DUAL TIRE KIT

02253

KEY	TENNANT® PART NO.	MACHINE SERIAL NUMBER	DESCRIPTION	QTY.
	28500	(-)	TIRE KIT, Dual	1
	47807	(-)	TIRE AND WHEEL ASSEMBLY, Non marking	4
	28211	(-)	WHEEL HALF	1
	28128	(-)	WHEEL HALF	1
	28311	(-)	TIRE	1
	27028	(-)	CASTER	1
	27055	(-)	SLEEVE	6
	19881	(-)	PANEL, Filler	1
	19884	(-)	BRACE	1
	19887	(-)	EXTENSION	1

FIG. 4 - BRAKE KIT

02254

KEY	TENNANT® PART NO.	MACHINE SERIAL NUMBER	DESCRIPTION	QTY.
	29783	(-)	BRAKE KIT	1
	29784	(-)	PLATE, Brake	1
	28008	(-)	RETAINER	1
	29785	(-)	BLOCK, Brake	1

FIG. 5 - BATTERY CHARGER KIT

02255

KEY	TENNANT® PART NO.	MACHINE SERIAL NUMBER	DESCRIPTION	QTY.
	29171	(-)	CHARGER, Battery, MAC	1

FIG. 6 - BATTERY CHARGER KIT

02256

KEY	TENNANT® PART NO.	MACHINE SERIAL NUMBER	DESCRIPTION	QTY.
	29174	(-)	CHARGER, Battery, AMC	1

FIG. 7 - BATTERY CHARGER KIT, 60 HZ

02239

KEY	TENNANT® PART NO.	MACHINE SERIAL NUMBER	DESCRIPTION	QTY.
	29225A	(-)	BATTERY CHARGER KIT	1
	29888	(-)	WIRE KIT	1
	29863	(-)	TUBE, Heatshrink	2
	29749	(-)	CORD ASSEMBLY	1
	29864	(-)	DECAL, Charger input	1
	29232	(-)	STRAIN RELIEF	1
	29688	(-)	AMMETER	1
	04126C	(-)	TERMINAL	1
	50708	(-)	CHARGER, Battery	1
	29199	(-)	PLATE	1
	29198	(-)	CLIP, Cord	2

FIG. 8 - BATTERY CHARGER GROUP, 60 HZ, EE

02240

KEY	TENNANT® PART NO.	MACHINE SERIAL NUMBER	DESCRIPTION	QTY.
	30016	(-)	BATTERY CHARGER KIT, 60 HZ, EE	1
	30015	(-)	WIRE KIT, EE	1
	29863	(-)	TUBE, Heatshrink	2
	29749	(-)	CORD ASSEMBLY	1
	29864	(-)	DECAL, Charger input	1
	29232	(-)	STRAIN RELIEF	1
	29688	(-)	AMMETER	1
	04126C	(-)	TERMINAL, Spade	1
	50708	(-)	CHARGER, Battery	1
	29199	(-)	PLATE, Battery tray	1
	31005	(-)	CLIP, Cord	2

FIG. 9 - BATTERY CHARGER TIMER, 60HZ

02241

KEY	TENNANT® PART NO.	MACHINE SERIAL NUMBER	DESCRIPTION	QTY.
	50495	(-)	TIMER KIT, 60 HZ	1
1	61106	(-)	KNOB	1
2	61108	(-)	DECAL, Timer	1
3	50496	(-)	TIMER	1
4	29863	(-)	TUBE, Heatshrink	1

FIG. 10 - BATTERY CHARGER TIMER, 50HZ

02859

KEY	TENNANT® PART NO.	MACHINE SERIAL NUMBER	DESCRIPTION	QTY.
	50723	(-)	TIMER KIT, 50HZ	1
	61106	(-)	KNOB	1
	61108	(-)	DECAL, Timer	1
	50729	(-)	TIMER	1
	29683	(-)	TUBE, Heatshrink	1

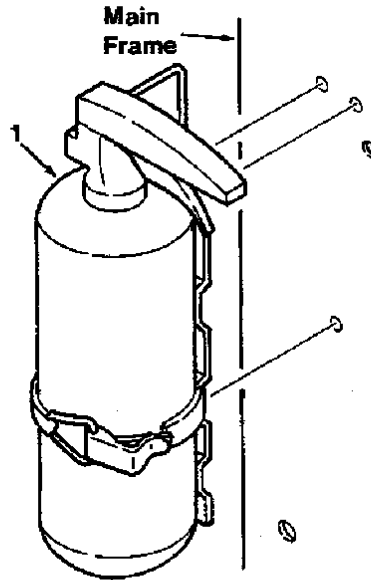

FIG. 11 - FIRE EXTINGUISHER KIT

00713

KEY	TENNANT® PART NO.	MACHINE SERIAL NUMBER	DESCRIPTION	QTY.
	46938	(-)	EXTINGUISHER KIT, Fire	1
1	25312	(-)	EXTINGUISHER, Fire	1

FIG. 12 - HOUR METER KIT

02242

KEY	TENNANT® PART NO.	MACHINE SERIAL NUMBER	DESCRIPTION	QTY.
	29869	(-)	HOUR METER KIT	1
1	29870	(-)	WIRE KIT	1
2	47164	(-)	DECAL, 15 A	1
3	07422	(-)	FUSE HOLDER	1
4	31051	(-)	FUSE, 15 A	1
5	29292	(-)	DECAL, Engine hour meter	1
6	24518	(-)	METER, Engine hour	1

NOTE: To identify parts shown but not listed here, see Section 5, Standard Model Parts.

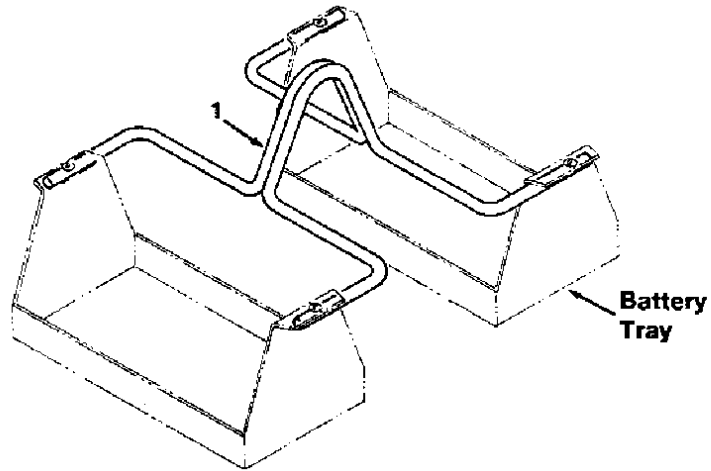

FIG. 13 - BATTERY HOIST KIT

01004

KEY	TENNANT® PART NO.	MACHINE SERIAL NUMBER	DESCRIPTION	QTY.
	29167	(-)	HOIST KIT, Battery	1
	29165	(-)	HOIST, Battery	1

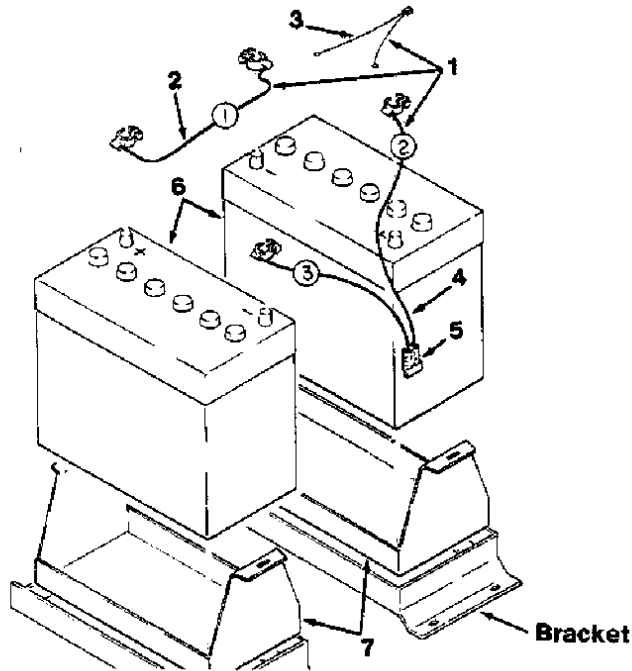

FIG. 14 - BATTERY KIT, DRY, HD-EE

02243

KEY	TENNANT® PART NO.	MACHINE SERIAL NUMBER	DESCRIPTION	QTY.
	31017-3	(-)	BATTERY KIT, Dry	1
1	50483	(-)	WIRE KIT, Battery	1
2	50480	(-)	CABLE ASSEMBLY, Battery	1
3	50482	(-)	WIRE ASSEMBLY, Shaker	1
4	50481	(-)	CABLE ASSEMBLY, Battery	1
5	24881	(-)	CONNECTOR	1
6	19592	(-)	BATTERY, 12 V, 125 A/H	2
7	29110	(-)	TRAY, Battery	2

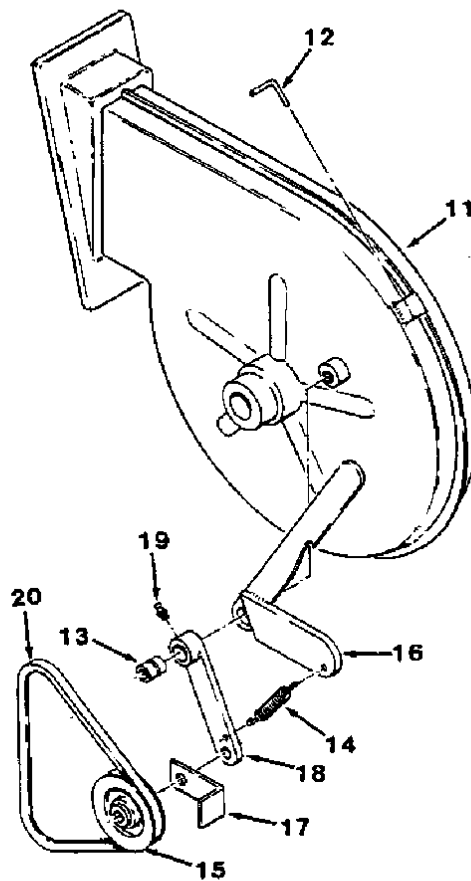
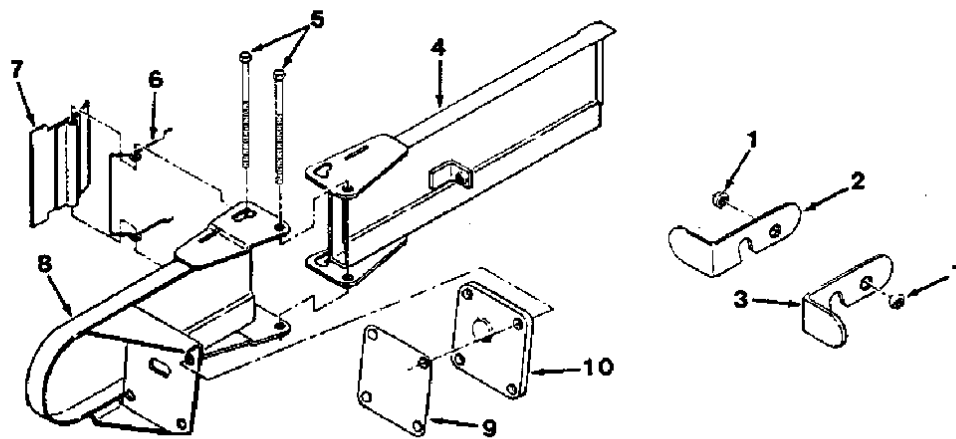

FIG. 15 - PREP FOR SCRUB KIT

FIG. 15 - PREP FOR SCRUB KIT

02249

NOTE: SCRUB ATTACHMENT, TENNANT® PART NUMBER 29935, INCLUDES FIG. 16, 18, 19, 20, 21, 22, AND 23.

KEY	TENNANT® PART NO.	MACHINE SERIAL NUMBER	DESCRIPTION	QTY.
	28777	(-)	PREP FOR SCRUB KIT	1
1	29534	(-)	SLEEVE	2
2	29984	(-)	CATCH, Scrubber tank, R.H.	1
3	29983	(-)	CATCH, Scrubber tank, L.H.	1
4	28566A	(-)	ARM, Side	1
5	33263	(0000000000-0000011596)	REPLACEMENT KIT, Pin	2
5	48418	(0000011597-	SCREW, Hex	2
6	28564	(-)	SPRING, Torsion	1
7	28563	(-)	SHIELD ASSEMBLY	1
8	29728A	(-)	ARM, Side	1
9	28078	(-)	GASKET	1
10	29629	(-)	PLATE, Gear head	1
	32413	(-)	V-BELT	1
	29976	(-)	DECAL, Brush lift	1
	29848	(-)	DUCT AND HOUSING ASSEMBLY, Fan	1
	31066	(-)	HOUSING ASSEMBLY, Fan	1
11	29707	(-)	HOUSING, Impeller	1
12	29715	(-)	RETAINER, Clutch	1
	00911	(-)	KEY, Square	1
	00954	(-)	KEY, Square	1
	23217	(-)	RING, Retaining	2
	23444	(-)	IMPELLER	1
13	26065	(-)	SLEEVE	1
14	28281	(-)	SPRING, Tension	1
	28939	(-)	BEARING AND SHAFT	1
	29120	(-)	SHEAVE	1
	28988-1	(-)	SEAL, Foam	2
	28988-2	(-)	SEAL, Foam	2
	28938	(-)	SEAL, Felt	1
	28627	(-)	DECAL, Up-sweep, down-scrub	1
15	19818	(-)	IDLER ASSEMBLY	1
	32602	(-)	SLEEVE	1
16	29709	(-)	LEVER	1
17	29714	(-)	RETAINER, Belt	1
18	29719	(-)	ARM	1
	29129-1	(-)	DUCT AND SUPPORT ASSEMBLY, Fan	1
	28938-1	(-)	SEAL, Felt	1
19	07259	(-)	FITTING, Grease	1
20	26161	(-)	V-BELT	1
	07421	(-)	PLATE, On-off, switch	1
	47178-8	(-)	PLUGBUTTON	1
	56992	(-)	PLUGBUTTON	1
	47132	(-)	SWITCH	1
	28744	(-)	BRACKET, Instrument	1
	29295	(-)	DECAL, Brush lift, vertical	1
	29169	(-)	DECAL, On-off	1
	29736	(-)	SWITCH, Toggle	1
	29294	(-)	DECAL, Scrub vacuum	1
	07422	(-)	FUSE HOLDER, Panel mounted	1
	31051	(-)	FUSE, 15 A	1
	47164	(-)	DECAL, 15 A	1
	29293	(-)	DECAL, Scrub vacuum motor	1
	29739A	(-)	WIRE KIT, Prep for scrub	1
	29883	(-)	CLIP, Finger grip	2
	29296	(-)	CONNECTOR, Bracket	1
	33236	(-)	CLIP, Tension	2
	39273	(-)	NUT, Wing	1

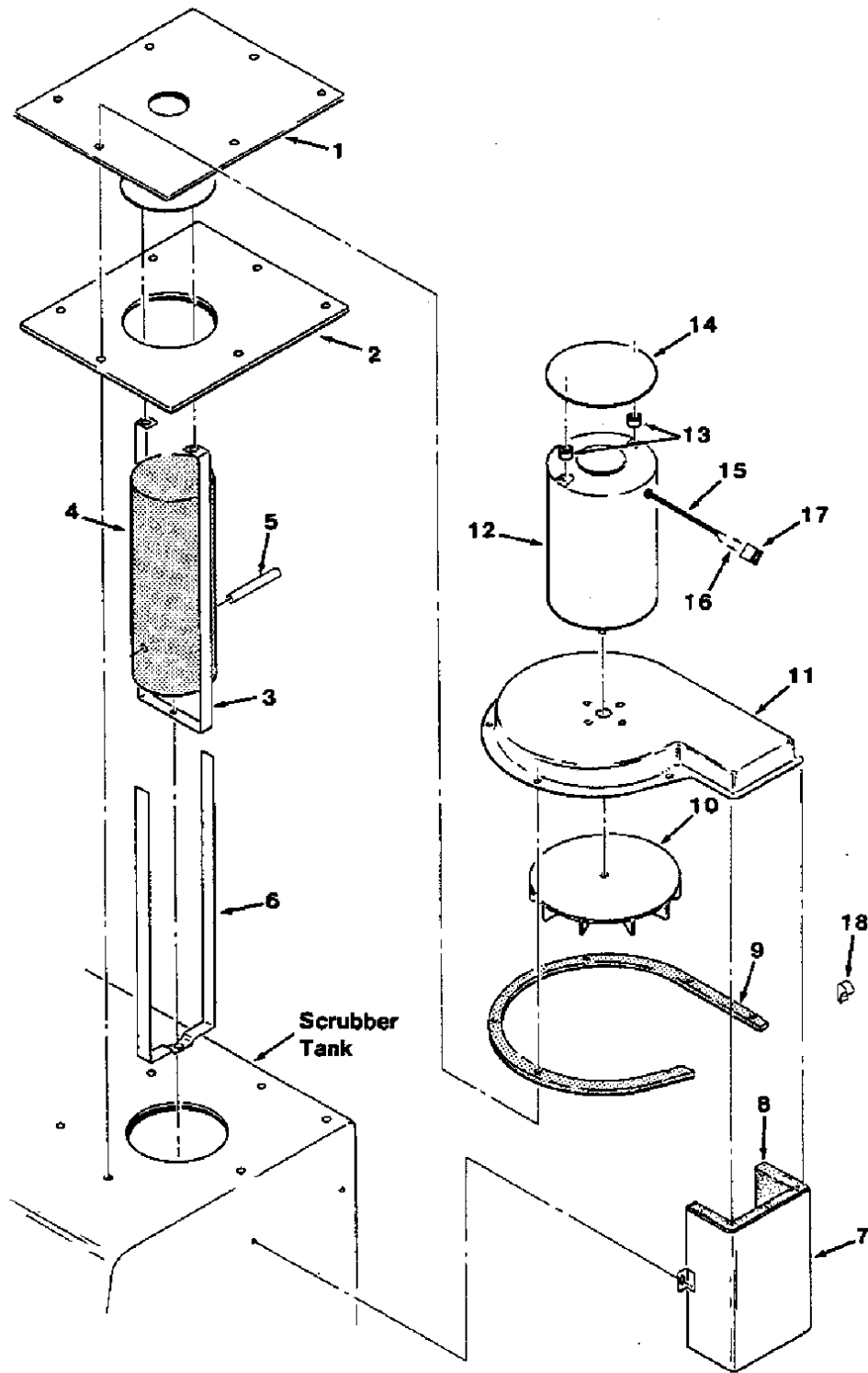

FIG. 16 - VACUUM FAN GROUP, SCRUB

FIG. 16 - VACUUM FAN GROUP, SCRUB

01017

NOTE: SCRUB ATTACHMENT, TENNANT® PART NUMBER 29935, INCLUDES FIG. 16, 18, 19, 20, 21, 22, AND 23.

KEY	TENNANT® PART NO.	MACHINE SERIAL NUMBER	DESCRIPTION	QTY.
1	29550	(-)	TUBE, Shut-off	1
2	29548	(-)	GASKET, Plate	1
3	29333	(-)	STRAP, Float	1
4	29923	(-)	FLOAT ASSEMBLY.	1
5	29928	(-)	BAR	1
6	29334	(-)	STRAP, Float retainer	1
7	29752	(-)	MUFFLER ASSEMBLY	1
8	29766	(-)	FOAM	1
9	20249	(-)	SEAL	1
10	20288	(-)	IMPELLER	1
11	20289-1	(-)	HOUSING, Impeller	1
12	29733	(-)	MOTOR, Electric	1
13	01275	(-)	SLEEVE	2
14	29738	(-)	COVER, Motor	1
15	29779	(-)	PROTECTOR, Wire	1
16	29859	(-)	PIN, Male	2
17	29857	(-)	HOUSING, Pin	1
18	09385	(-)	CLAMP, Cable	1

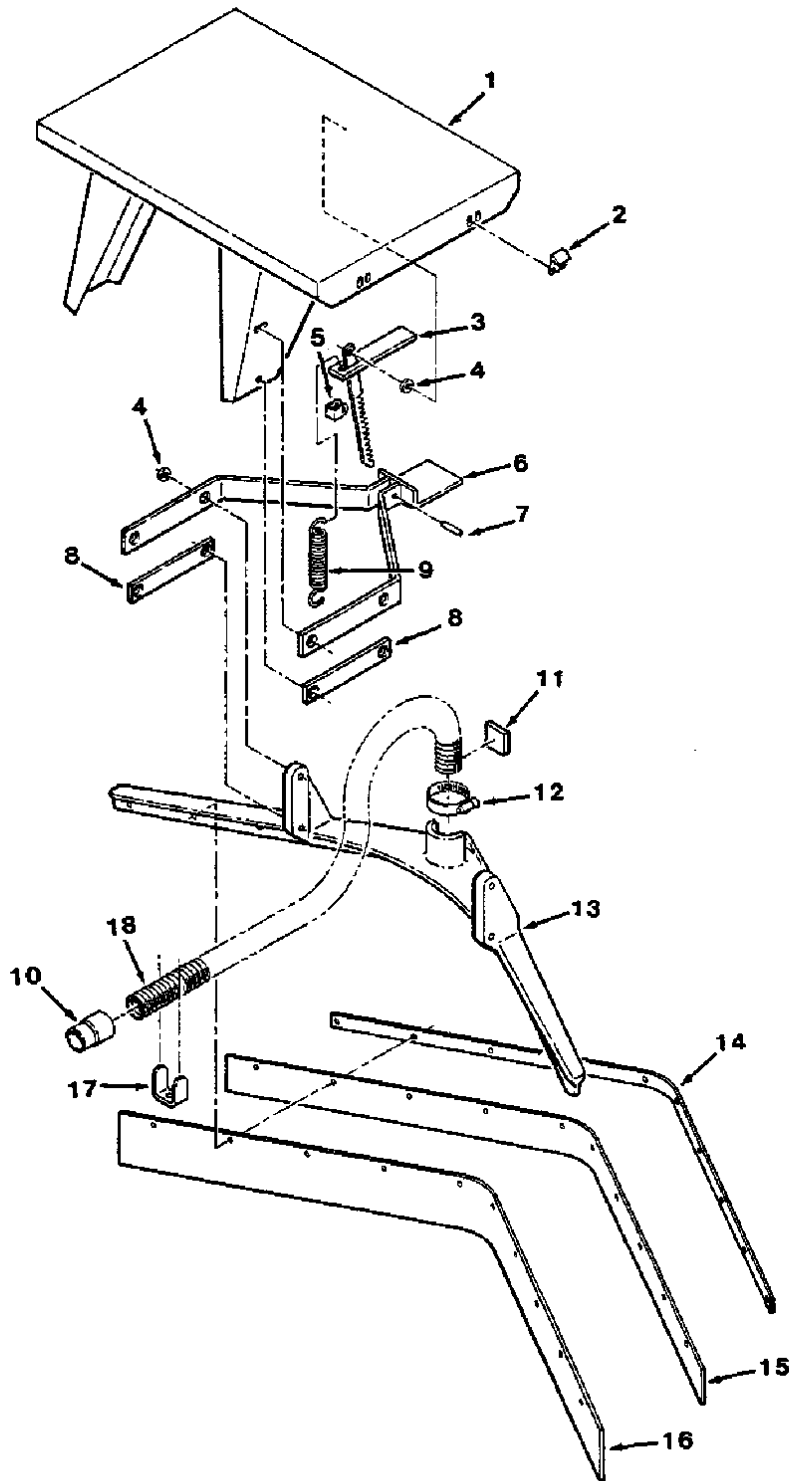

FIG. 17 - REAR SQUEEGEE GROUP

FIG. 17 - REAR SQUEEGEE GROUP

01021

NOTE: SCRUB ATTACHMENT, TENNANT® PART NUMBER 29935, INCLUDES FIG. 16, 18, 19, 20, 21, 22, AND 23.

KEY	TENNANT® PART NO.	MACHINE SERIAL NUMBER	DESCRIPTION	QTY.
1	29559	(000000000-xxxxxxxxxx)	PLATE	1
2	09182-2	(000000000-xxxxxxxxxx)	STRIKE, Catch	4
3	29576	(000000000-xxxxxxxxxx)	RATCHET	1
4	20318	(000000000-xxxxxxxxxx)	SLEEVE	9
5	29759	(000000000-xxxxxxxxxx)	STOP	1
6	29634	(000000000-xxxxxxxxxx)	PEDAL	1
7	22134	(000000000-xxxxxxxxxx)	PIN, Roll	1
8	29321	(000000000-xxxxxxxxxx)	LINK	2
9	29499	(000000000-xxxxxxxxxx)	SPRING, Tension	1
10	29690	(000000000-xxxxxxxxxx)	CUFF, Hose	1
11	29662	(000000000-xxxxxxxxxx)	BAR, Rubber	1
12	29696	(000000000-xxxxxxxxxx)	CLAMP, Wormdrive	1
13	29538	(000000000-xxxxxxxxxx)	SQUEEGEE	1
14	29541	(000000000-xxxxxxxxxx)	RETAINER	1
15	29540	(000000000-xxxxxxxxxx)	BLADE, Back-up	1
16	29539	(000000000-xxxxxxxxxx)	BLADE, Squeegee	1
17	29755	(000000000-xxxxxxxxxx)	BRACKET, Hose	1
18	29691	(000000000-xxxxxxxxxx)	HOSE AND CUFF ASSEMBLY	1

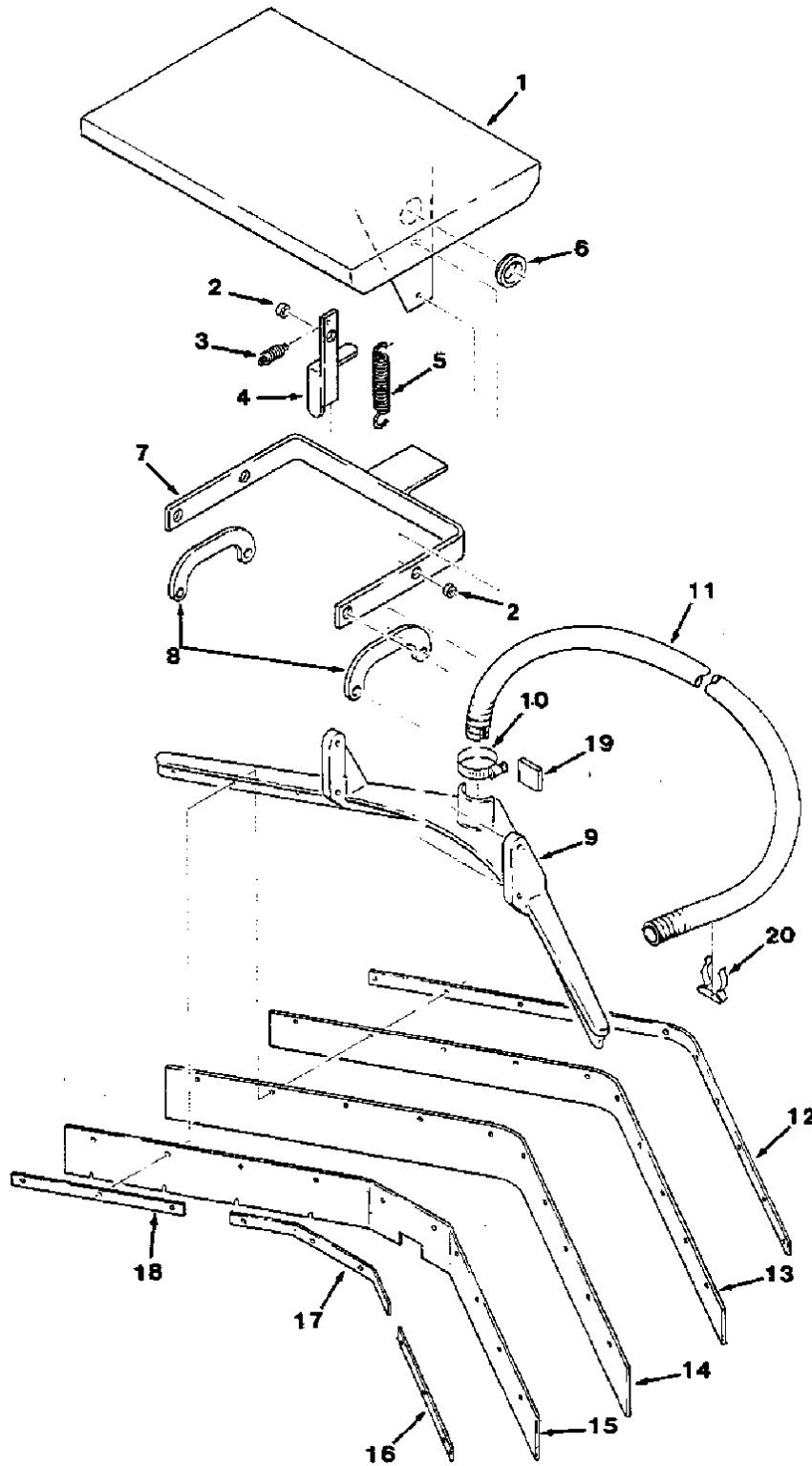

FIG. 18 - REAR SQUEEGEE ASSEMBLY

FIG. 18 - REAR SQUEEGEE ASSEMBLY

01019

NOTE: SCRUB ATTACHMENT, TENNANT® PART NUMBER 29935, INCLUDES FIG. 16, 18, 19, 20, 21, 22, AND 23.

KEY	TENNANT® PART NO.	MACHINE SERIAL NUMBER	DESCRIPTION	QTY.
	29892	(xxxxxxxxxx-)	SQUEEGEE ASSEMBLY, Rear	1
1	29958	(xxxxxxxxxx-)	BASE, Squeegee	1
2	20318	(xxxxxxxxxx-)	SLEEVE	9
3	09087	(xxxxxxxxxx-)	SPRING, Tension	1
4	29953	(xxxxxxxxxx-)	SUPPORT	1
5	13352	(xxxxxxxxxx-)	SPRING, Tension	1
6	47080	(xxxxxxxxxx-)	GROMMET	1
7	29957	(xxxxxxxxxx-)	PEDAL	1
8	29945	(xxxxxxxxxx-)	LINK, Squeegee	2
9	29538	(xxxxxxxxxx-)	SQUEEGEE	1
10	29696	(xxxxxxxxxx-)	CLAMP, Wormdrive	1
11	29474	(xxxxxxxxxx-)	HOSE, Rubber	1
12	29541	(xxxxxxxxxx-)	RETAINER	1
13	29540	(xxxxxxxxxx-)	BLADE, Back up	1
14	29539	(xxxxxxxxxx-)	BLADE, Squeegee	1
15	29931	(xxxxxxxxxx-)	STRIP, Front	1
16	29929	(xxxxxxxxxx-)	RETAINER	1
17	29930	(xxxxxxxxxx-)	RETAINER	1
18	29927	(xxxxxxxxxx-)	RETAINER	1
19	29662	(xxxxxxxxxx-)	BAR, Rubber	1
20	29883	(xxxxxxxxxx-)	CLIP, Finger grip	2



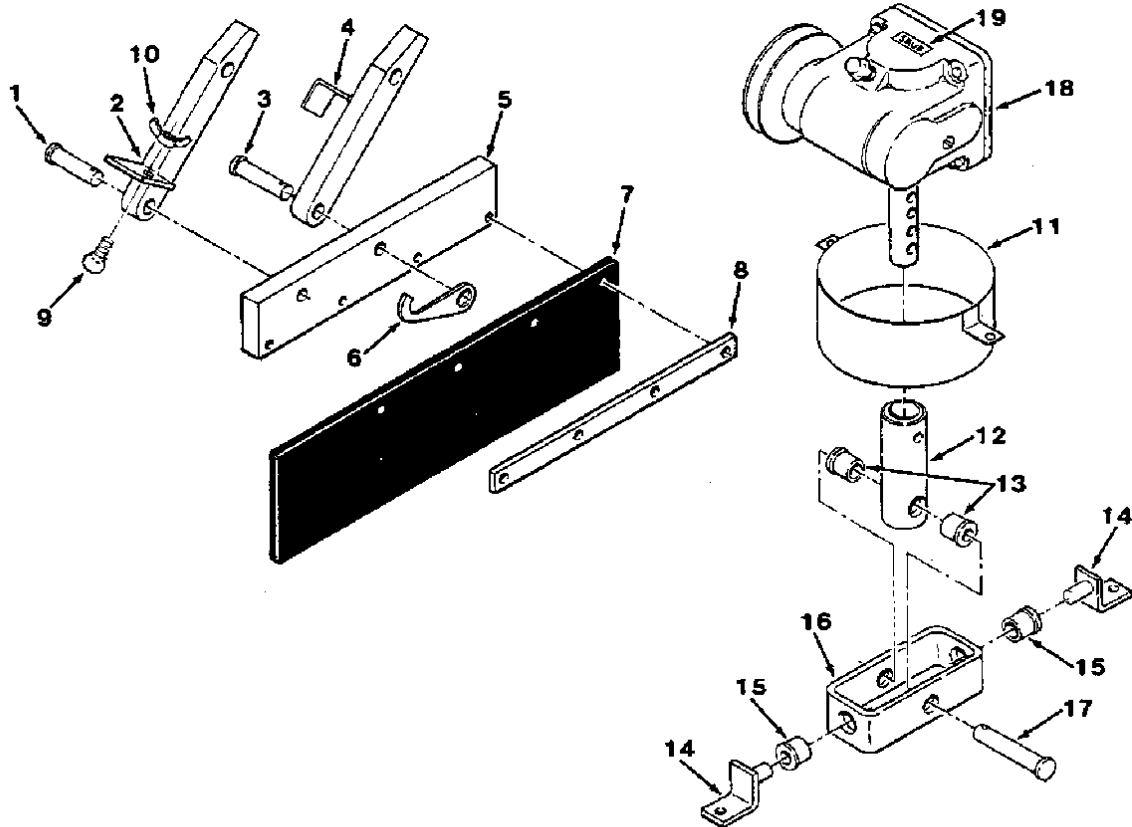

FIG. 19 - SIDE BRUSH AND SQUEEGEE ASSEMBLIES

01013

NOTE: SCRUB ATTACHMENT, TENNANT® PART NUMBER 29935, INCLUDES FIG. 16, 18, 19, 20, 21, 22, AND 23.

KEY	TENNANT® PART NO.	MACHINE SERIAL NUMBER	DESCRIPTION	QTY.
	29893	(-)	SIDE SQUEEGEE ASSEMBLY	1
1	29557	(-)	PIN, Clevis	1
2	29555	(-)	LINK	1
3	29558	(-)	PIN, Clevis	1
4	29567	(-)	LINK	1
5	29552	(-)	ARM	1
6	43206	(-)	CATCH	1
7	29383	(-)	BLADE, Squeegee	1
8	29380	(-)	RETAINER	1
9	39362	(-)	SCREW, Thumb	1
10	39272	(-)	NUT, Wing	1
	29897	(-)	REDUCER AND SWIVEL ASSEMBLY, Scrub	1
11	29592	(-)	RING	1
12	29586	(-)	TUBE, Hub	1
13	29585	(-)	BUSHING, Flange	2
14	31039	(-)	PIVOT	2
15	29585	(-)	BUSHING, Flange	2
16	31037	(-)	TUBE, Swivel box	1
17	29584	(-)	PIN, Clevis	1
18	29535	(-)	REDUCER, Gear	1
19	29868	(-)	DECAL, Scrub	1

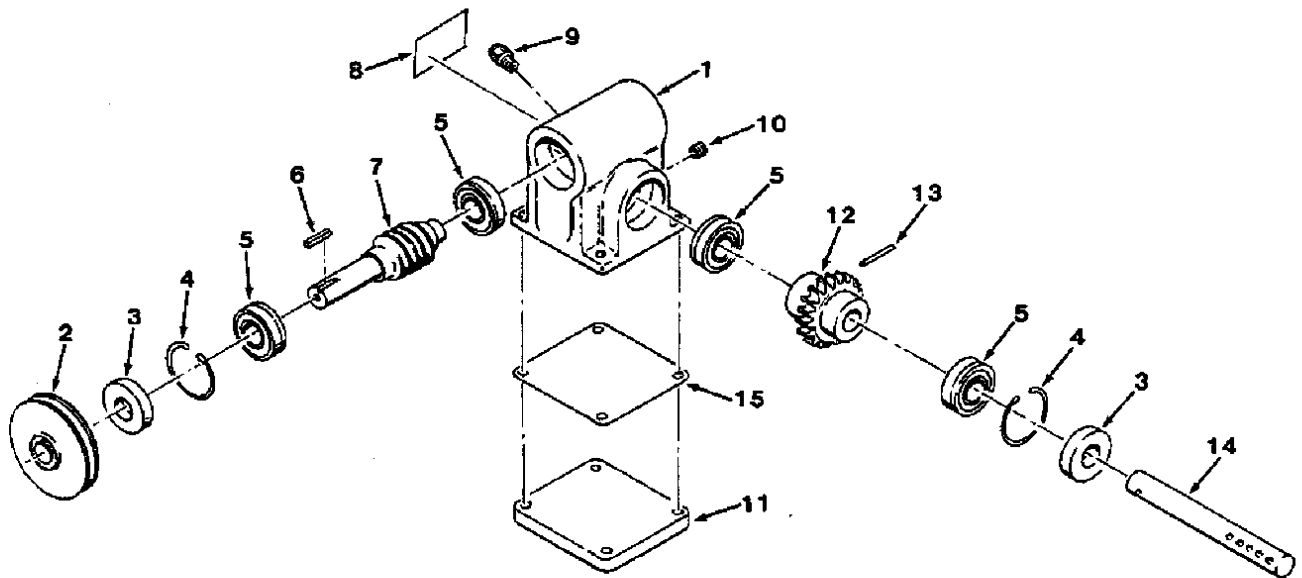

FIG. 20 - SIDE BRUSH SPEED REDUCER, SCRUB

02248

NOTE: SCRUB ATTACHMENT, TENNANT® PART NUMBER 29935, INCLUDES FIG. 16, 18, 19, 20, 21, 22, AND 23.

KEY	TENNANT® PART NO.	MACHINE SERIAL NUMBER	DESCRIPTION	QTY.
1	29535	(-)	REDUCER, Gear	1
2	28121	(-)	SHEAVE	1
3	28084	(-)	SEAL, Oil	2
4	01513	(-)	RING, Retaining	2
5	28011	(-)	BEARING, Ball	4
6	00911	(-)	KEY, Square	1
7	29661	(-)	WORM	1
8	29868	(-)	DECAL, Scrub	1
9	07316-15	(-)	BREATHER	1
10	02246	(-)	FITTING, Plug	1
11	29629	(-)	PLATE, Gear head	1
12	26493	(-)	GEAR	1
13	28144	(-)	PIN, Roll	1
14	28041	(-)	SHAFT, Reducer	1
15	28078	(-)	GASKET	1

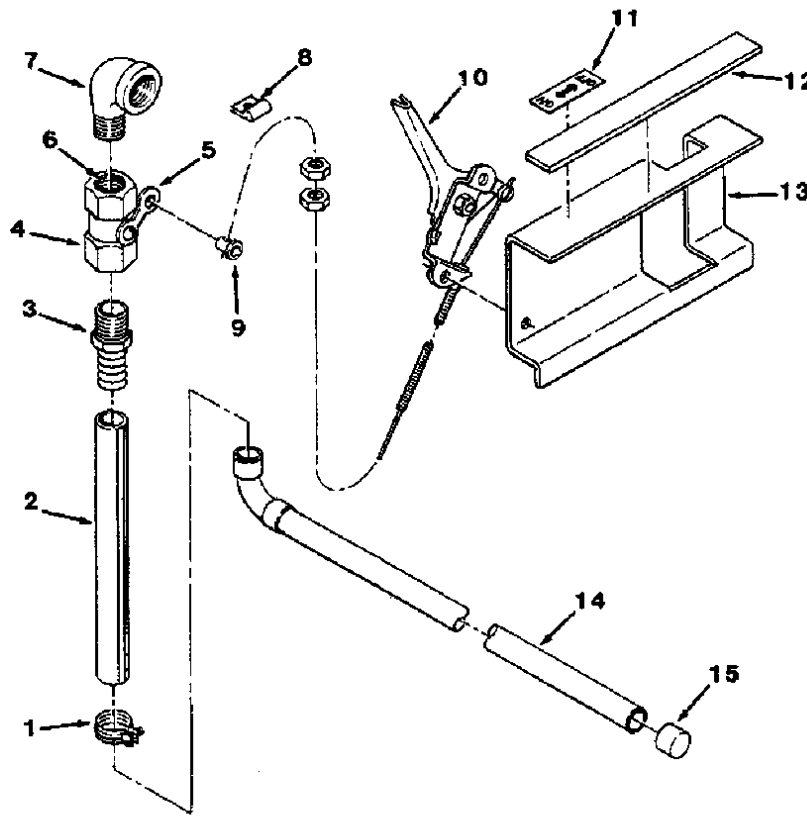

FIG. 21 - SOLUTION CONTROL GROUP

01008

NOTE: SCRUB ATTACHMENT, TENNANT® PART NUMBER 29935, INCLUDES FIG. 16, 18, 19, 20, 21, 22, AND 23.

KEY	TENNANT® PART NO.	MACHINE SERIAL NUMBER	DESCRIPTION	QTY.
1	43274	(0000000000-xxxxxxxxxx)	CLAMP	1
2	29601	(-)	HOSE, Vinyl	1
3	43246	(-)	CONNECTOR	1
4	43379-1	(-)	VALVE ASSEMBLY	1
5	20347	(-)	ARM	1
6	20350	(-)	SEAL, O-ring	1
7	29600	(-)	FITTING, Elbow	1
8	26414	(-)	CLAMP, Cable	1
9	43242	(-)	SWIVEL	1
10	SK1838	(0000000000-xxxxxxxxxx)	REPLACEMENT KIT, Cable	1
10	27354	(xxxxxxxxxx-	CABLE ASSEMBLY, Control	1
11	29638	(-)	DECAL, On-off	1
12	29233	(0000000000-xxxxxxxxxx)	BUMPER	1
13	29589	(-)	BRACKET, Cable	1
14	31042	(-)	SPREADER, Water	1
15	47639	(-)	CAP, Rubber	1

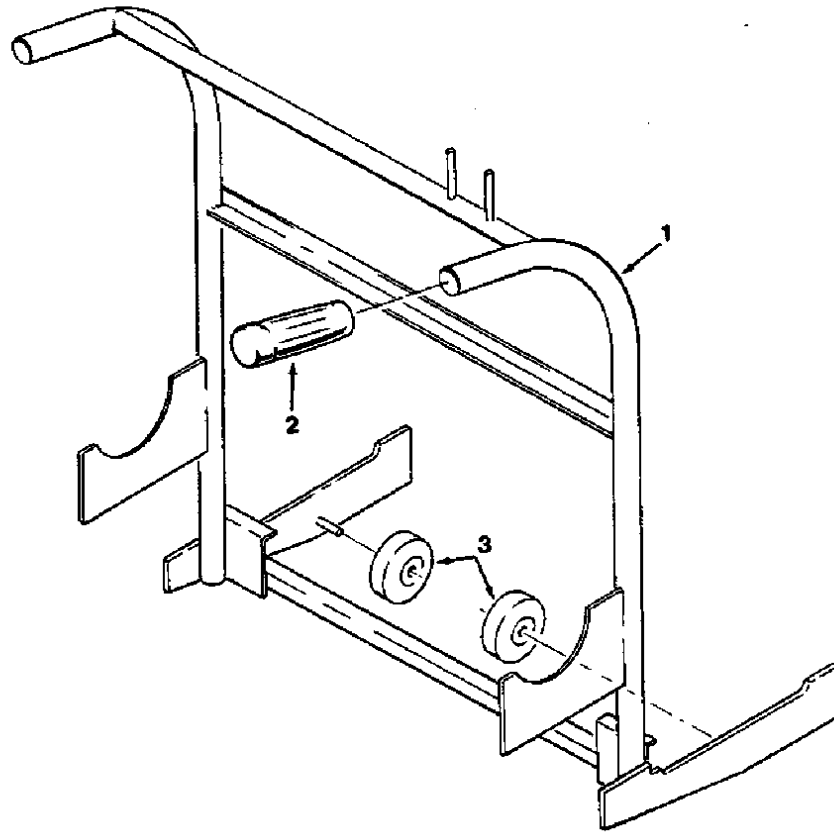

FIG. 22 - SCRUBBER CART ASSEMBLY

C2250

NOTE: SCRUB ATTACHMENT, TENNANT® PART NUMBER 29935, INCLUDES FIG. 16, 18, 19, 20, 21, 22, AND 23.

KEY	TENNANT® PART NO.	MACHINE SERIAL NUMBER	DESCRIPTION	QTY.
	29844	(-)	SCRUBBER CART	1
1	29808	(-)	CART	1
2	28162	(-)	GRIP, Handle	2
3	29653	(-)	WHEEL	2

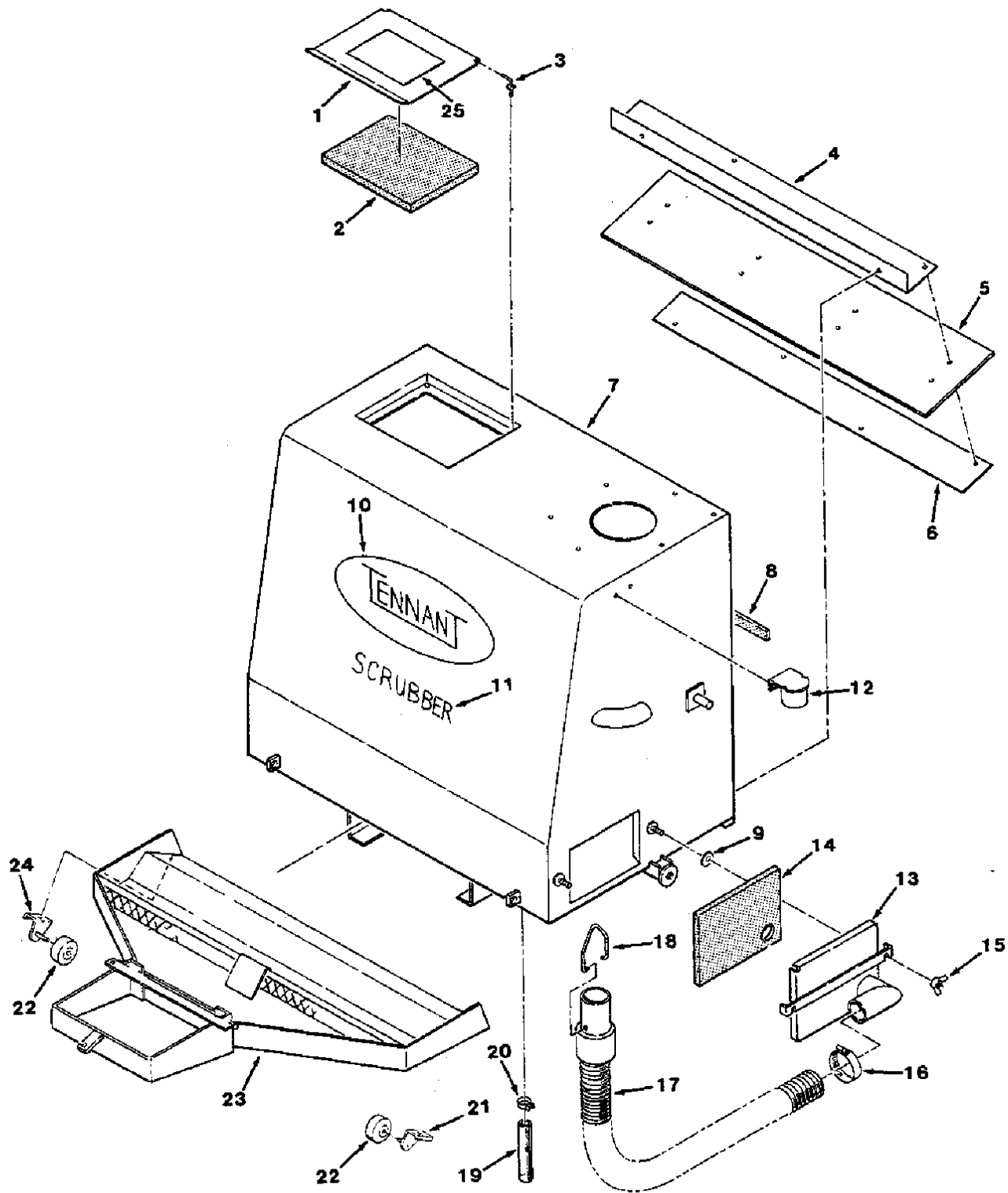

FIG. 23 - SCRUB TANK GROUP

FIG. 23 - SCRUB TANK GROUP

01018

NOTE: SCRUB ATTACHMENT, TENNANT® PART NUMBER 29935, INCLUDES FIG. 16, 18, 19, 20, 21, 22, AND 23.

KEY	TENNANT® PART NO.	MACHINE SERIAL NUMBER	DESCRIPTION	QTY.
1	29685	(-)	LID ASSEMBLY, Tank	1
2	29531	(-)	GASKET, Lid	1
3	22133	(-)	FASTENER	2
4	29648	(-)	DEFLECTOR	1
5	29649	(-)	SKIRT, Deflector	1
6	29665	(-)	RETAINER	1
7	29506	(-)	TANK ASSEMBLY, Scrubber	1
8	29620	(-)	SEAL, Foam	1
9	76426	(-)	WASHER	2
10	28613-2	(-)	DECAL, Oval	1
11	24556-1	(-)	DECAL, Scrubber	1
12	20215	(-)	PLUG	1
13	29684	(-)	DOOR ASSEMBLY	1
14	29522	(-)	SEAL, Door	1
15	26509	(-)	NUT, Wing	2
16	29696	(-)	CLAMP, Wormdrive	1
17	29693	(-)	HOSE AND CUFF ASSEMBLY	1
18	20267	(000000000-xxxxxxxxxxx)	CLIP, Retainer	1
19	29605	(-)	HOSE, Rubber	1
20	11399	(-)	CLAMP, Wormdrive	1
	29683	(-)	TRAY ASSEMBLY	1
21	29936	(-)	BRACKET, Caster, L.H.	1
22	01847	(-)	WHEEL	2
23	29524A	(-)	TRAY, Pick up	1
24	29937	(-)	BRACKET, Caster, R.H.	1
25	46847	(-)	DECAL, Detergent recommended	1

