

FLOOR-EQUIPMENT-PARTS.COM



92 GR

(Operator Manual)





This manual is furnished with each new TENNANT® Model 92GR. It provides necessary operating and preventive maintenance instructions. Read this manual completely and understand the machine before operating or servicing it.

This manual covers all machine variations and standard accessories. The tabbed instruction portion of the manual consists of the Specification, Operation, Maintenance, and Appendix sections. The tabbed parts section consists of the Standard Model Parts, Accessories, Hydraulic Components, and Engine Parts sections.

All right side and left side references to the machine are determined by facing the direction of forward travel. All hardware considered to be of a common nature or locally available has been omitted from the parts sections. Be aware that this machine may contain metric hardware. Make sure you use equivalent hardware when replacement becomes necessary.

This machine will provide excellent service. However, the best results will be obtained at minimum costs if:

- The machine is operated with reasonable care.
- The machine is maintained regularly – per the maintenance instructions provided.
- The machine is maintained with Tennant Company supplied or equivalent parts.

Parts and supplies may be ordered by phone or mail from any Tennant Company parts and service center, distributor, or from any of the Tennant Company subsidiaries. Before ordering parts or supplies, be sure to have your machine model number and serial number handy. Fill out the data block below for future reference. The telephone numbers, telex numbers, mailing addresses, and locations of those outlets are listed in the Customer Documents section of the manual.

MACHINE DATA	
<i>Please fill out at time of installation.</i>	
Machine Serial Number –	_____
Engine Serial Number –	_____
Sales Representative –	_____
Date of Installation –	_____
Manual Number –	MM188
Revision:	02
Published:	11–87
	04300

Trademark Registered in: Austria, Benelux, Denmark, England, France, Germany, Italy, Spain, Switzerland, United States, Argentina, Australia, Canada, Japan, Mexico, Sweden, by TENNANT COMPANY, Minneapolis, Minnesota, U.S.A.

Acknowledgments: Technical information and/or illustrations supplied by Teledyne Continental Motors, Industrial Products Division; Cessna Fluid Power Division; Eaton Corporation, Hydraulics Division.

Copyright 1987 Tennant Company, Printed in U.S.A.

INSTALLATION REPORT

MODEL 92GR

NOTE: This report must be completed, signed and returned.

customer

date installed

address

machine serial
number

city

state

engine model
and serial number

telephone number

Tennant Company
Representative

OPERATION OF CONTROLS

- DIRECTIONAL CONTROL PEDAL
- STEERING WHEEL AND BRAKES
- THROTTLE LEVER
- ENGINE GAUGES
- SIDE BRUSH LEVER
- MAIN BRUSH SPEED LEVER
- MAIN BRUSH POWER LIFT LEVER
- HOPPER DOOR LEVER
- VACUUM FAN AND HOPPER LIFT LEVER
- MAIN BRUSH LIFT LEVER
- SIDE BRUSH ADJUSTMENT KNOB
- MAIN BRUSH HEIGHT ADJUSTMENT KNOB
- MAIN BRUSH PRESSURE KNOB
- FILTER SHAKER BUTTON
- CLOGGED DUST FILTER INDICATOR

MACHINE OPERATION

- SAFETY PRECAUTIONS
- STARTING ENGINE
- INSTRUCTION MANUAL, EXPLAIN USE
- TYPICAL SWEEPING PROCEDURES
- DUMPING HOPPER
- USING HOPPER SUPPORT BAR

LUBRICATION AND MAINTENANCE

- LUBRICATION AND MAINTENANCE CHART
- CHANGING HYDRAULIC FLUID, CAPACITY OF RESERVOIR

HYDRAULIC FLUID FILTER

TENNANT HYDRAULIC FLUID RECOMMENDED

ENGINE:

- DIPSTICK LOCATION
- CHANGING ENGINE OIL
- FUEL TANK LOCATION
- CHANGING OIL FILTER
- SERVICING AIR CLEANER
- FUEL FILTERS
- RADIATOR
- REPLACING DUST FILTERS
- REPLACING BRUSHES
- DUST SKIRT FLOOR CLEARANCE
- HOPPER LIP FLOOR CLEARANCE
- LOCATION OF CIRCUIT BREAKERS AND HOPPER FUSIBLE LINK
- BRAKE ADJUSTMENTS:
 - SERVICE BRAKES
 - PARKING BRAKES
- SEAT ADJUSTMENTS

TENNANT COMPANY WARRANTY

LOCAL SERVICE

HOW TO ORDER REPLACEMENT PARTS

PLANNED MAINTENANCE AGREEMENT

I have checked the equipment and acknowledge that I have been instructed by a Tennant Company Representative and understand and will comply with all of the procedures and safety measures checked above.

customer signature

title

date

COMMENTS:

SAFETY PRECAUTIONS

The following symbols are used throughout this manual as indicated in their descriptions:

 **WARNING:** To warn of hazards or unsafe practices which could result in severe personal injury or death.

 **CAUTION:** To warn of hazards or unsafe practices which could result in minor personal injury.

The following information signals potentially dangerous conditions to the operator or equipment. Read this manual carefully. Know when these conditions can exist. Locate all safety devices on the machine. Then take necessary steps to train machine operating personnel how to use those safety devices. Report machine damage or faulty operation immediately to personnel responsible for the repair of the machine. Do not use the machine if it is not in proper operating condition.

 **WARNING:** Do not operate the machine until you have read and understood the operating instructions and are properly trained. Failure to do so could result in severe personal injury.

 **WARNING:** Before operating the machine, make sure all safety devices are in place and operate properly. Check the foot and parking brakes and the steering control for proper operation. Do not start machine unless you are in operator's seat, with foot on the brake pedal or operational parking brake engaged and the directional pedal in the "neutral" position. Failure to do so could allow machine to move immediately upon start-up, resulting in severe personal injury.

 **WARNING:** Provide adequate ventilation when operating machine to prevent buildup of engine exhaust gases. Improper or inadequate ventilation will cause asphyxiation. Check exhaust system regularly for leaks.

 **WARNING:** Do not operate machine in flammable or explosive environment. Machine is not designed for such an environment. It could cause ignition of flammable or explosive materials.

 **WARNING:** Do not operate machine in areas with possible falling objects unless machine is equipped with overhead guard.

 **WARNING:** Dirt, dust, and debris may be thrown by the machine when in operation. Safety glasses or goggles must be worn by the machine operator to protect eyes. Failure to do so could cause serious eye injury.

 **WARNING:** Excessive noise may be generated by the machine when it is operated in certain confined or noisy areas or in certain conditions of disrepair. Hearing protection should be worn under such conditions to avoid hearing loss.

 **WARNING:** Do not carry riders on machine. Machine is designed to carry one operator; riders could fall off and become seriously injured.

 **WARNING:** Always follow safety and traffic rules of the area in which the machine is being operated to prevent serious injury.

 **WARNING:** Use care when backing machine to prevent injury to bystanders.

 **WARNING:** Do not drive the machine for any great distance or at high speed with the hopper raised. A raised hopper reduces machine stability.

 **WARNING:** Be sure adequate vertical clearance is available before attempting to high dump the hopper. Failure to do so could cause overhead objects to fall or could cause electrical shock if overhead wiring is contacted.

 **WARNING:** Always travel slowly on grades to prevent machine instability. Do not exceed maximum rated ramp climb and descent angles.

 **WARNING:** Machine should not creep when the directional control pedal is in the "neutral" position. Adjust control pedal linkage to stop machine creeping.

 **WARNING:** Always engage the hopper support bar before working under a raised hopper. Do not rely on the machine hydraulic system to keep the hopper in the “raised” position. The hydraulic system may leak internally, allowing the hopper to lower, crushing anything under it.

 **WARNING:** Avoid moving parts of the machine. Do not wear loose jackets, shirts, or sleeves when working on machine because of

the danger of becoming caught in moving parts. Keep shields and guards in position. Wear approved eye protection. If adjustments must be made while the engine is running, use extreme caution around hot manifolds, moving parts, belts, etc.

 **WARNING:** Always stop the machine on a level surface, stop the engine and engage the parking brake before working on the machine to keep it from rolling.

The following safety decals are mounted on the machine in the locations indicated. If these, or any, decals become damaged or illegible, install a new decal in its place.

ENGINE FAN LABEL LOCATED ON THE TOP AND SIDE OF THE RADIATOR FAN SHROUD.

FOR SAFETY

1. Do Not Operate Machine:
 - Unless Trained And Authorized.
 - Unless Operation Manual Is Read And Understood.
 - In Flammable Or Explosive Areas.
 - In Poorly Ventilated Areas.
2. Do Not Use Flammable Cleaning Agents
3. Check For Fuel Leaks.
4. Go Slow On Grades And Slippery Surfaces
5. Before Leaving Machine:
 - Stop On Level Surface
 - Stop Engine –And Set Parking Brake (If So Equipped).
 - When Parking, Remove Key
6. Use TENNANT COMPANY Supplied Or Equivalent Replacement Parts.

03781

FOR SAFETY LABEL LOCATED ON DUST SHIELD.

⚠ WARNING



Keep Away From Engine Fan.

03784

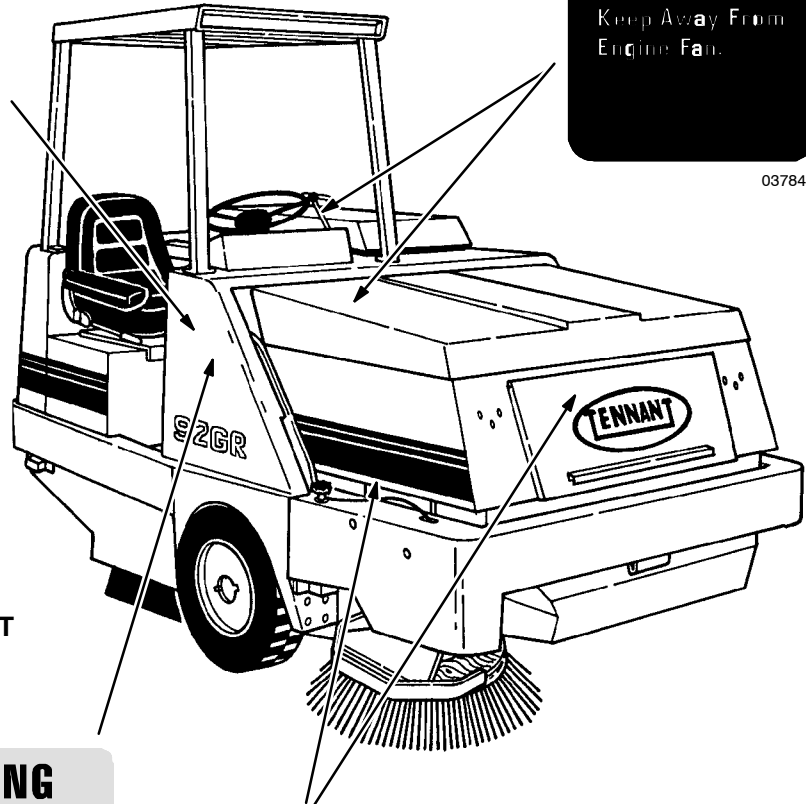

⚠ WARNING

Engine Emits Toxic Gases. Serious Injury or Death May Result. Provide Adequate Ventilation. Keep Engine Properly Tuned.

04412

TOXIC EMISSIONS LABEL LOCATED ON THE OPERATOR KICK PANEL.

⚠ CAUTION



Stay Clear Of Hopper Lift Arms.

03401

HOPPER LIFT ARM LABEL LOCATED ON RIGHT AND LEFT SIDE LIFT ARMS.

04300

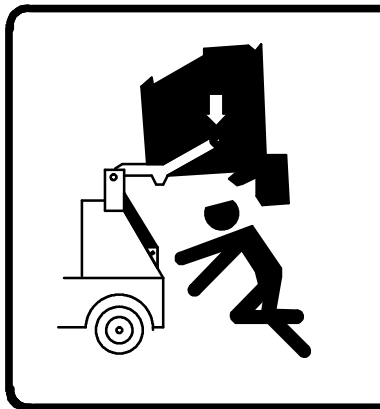

! WARNING

**Falling Hopper
Engage Safety
Support Bar
Per Instructions**



FALLING HOPPER LABEL LOCATED ON PUMP BAFFLE.

04321



! WARNING

**Falling Hopper
Engage Safety
Support Bar
Per Instructions**

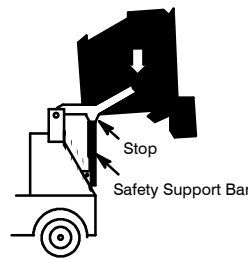

INSTRUCTIONS

To Engage Safety Support Bar:

1. Lift Hopper To Extreme Up Position.
2. Set Parking Brake.
3. Dismount Machine And Lower Safety Support Bar.
4. Lower Hopper Onto Support Bar.
5. Shut Off Engine.

FALLING HOPPER LABEL LOCATED ON LEFT SIDE LIFT ARM AND ON HOPPER SUPPORT BAR.

04306

04300

GENERAL INFORMATION

CONTENTS

	Page		Page
SAFETY PRECAUTIONS	i	Hopper Support Bar	2-9
		To Engage Hopper Support Bar ...	2-9
		To Disengage Hopper Support Bar	2-9
SECTION 1 – SPECIFICATIONS		Hydraulic Pressure Gauge	2-10
Machine Specifications	1-1	Stabilizer Leg	2-10
Machine Dimensions	1-3	Fuses and Circuit Breakers	2-10
SECTION 2 – OPERATION		Machine Operation	2-11
Preparation for Operation	2-1	Normal Sweeping Operation	2-11
Operation of Controls	2-2	Pre-Start Checklist	2-11
Machine Components	2-2	To Start Machine	2-11
Controls and Instruments	2-3	To Sweep	2-11
Brake Pedal	2-4	To Dump Hopper	2-12
Directional Pedal	2-4	Post Operation Checklist – Engine	
Main Brush Height Adjustment		Operating	2-12
Knob	2-4	To Stop Machine	2-12
Operator Seat	2-4	Post Operation Checklist – Engine	
Main Brush Speed Lever	2-5	Stopped	2-13
Main Brush Power Lift Lever	2-5	Operation on Grades	2-13
Throttle Lever	2-6	Machine Troubleshooting	2-14
Main Brush Pressure Knob	2-6	Transporting Machine	2-15
Side Brush Lever	2-6	Pushing or Towing Machine	2-15
Hopper Door Lever	2-6	Machine Jacking	2-15
Vacuum Fan and Hopper Lift		Machine Tie-Downs	2-16
Lever	2-6	Machine Storage	2-17
Main Brush Lift Lever	2-7	Storing Machine	2-17
Operating Lamps Switch	2-7	SECTION 3 – MAINTENANCE	
Hazard Lamp Switch	2-7	Recommended First 50-Hour Machine	
Turn Signal Lever	2-7	Inspection	3-1
Clogged Dust Filter Indicator	2-7	Maintenance Chart	3-2
Dust Filter Shaker Pushbutton		Lubrication	3-4
Switch	2-7	Engine	3-4
Dump Door Indicator	2-7	Rear Wheel Support Pivot	3-4
Fuel Level Gauge	2-7	Steering Gear	3-4
Engine Coolant Temperature		Side Brush Pivot Pins	3-5
Gauge	2-7	Stabilizer Leg Pivot Pin	3-5
Engine Oil Pressure Gauge	2-8	Front Wheel Bearings	3-5
Steering Wheel	2-8	Hydraulics	3-6
Brush Pressure Indicator	2-8	Hydraulic Fluid	3-6
Battery Condition Gauge	2-8	Hydraulic Fluid Reservoir	3-6
Engine Hour Meter	2-8	Hydraulic Fluid Filter	3-7
Side Brush Switch	2-8	To Replace the Hydraulic	
Diesel Pre-Heat Indicator	2-8	Fluid Filter Element	3-7
Ignition Switch	2-8	Directional Control Pedal “Neutral”	
Parking Brake	2-8	Position Adjustment	3-7
Side Brush Height Adjustment Knob ...	2-9	Speed Limiter	3-8
		Hydraulic Fluid Leaks	3-8

	Page		Page
Hydraulic Schematic	3-9	To Adjust Side Brush Bumper Clearance	3-32
Hydraulic System Troubleshooting	3-10	Skirts and Seals	3-33
Hydraulic Components Troubleshooting	3-12	Hopper Lip Skirts	3-33
Engine	3-13	To Replace Hopper Lip Skirts	3-33
Engine Lubrication	3-13		Page
Cooling System	3-13	Hopper Side Seals	3-33
Air Intake System	3-13	To Replace Hopper Side Seals	3-33
Air Filter Restriction Indicator	3-14	Brush Door Skirts	3-34
Air Filter	3-14	To Replace and Adjust Brush Door Skirts	3-34
To Replace Air Filter Element	3-14	Rear Skirts	3-35
Fuel System – Diesel	3-15	To Replace and Adjust Rear Skirts	3-35
Diesel Fuel System	3-15	Hopper Dust Dump Door Seal	3-35
Fuel Water Trap	3-15	To Replace Hopper Dust Dump Door Seal	3-35
To Clean Water Trap	3-15	To Check and Adjust Hopper Dust Dump Door Seal	3-36
Fuel Filter	3-16	Hinged Top Hopper Seal	3-37
To Replace Fuel Filter Element	3-16	To Replace and Adjust Hinged Top Hopper Seal	3-37
Fuel Injection Pump	3-16	Hopper Door Hinge Seal	3-38
Fuel Injectors	3-16	To Replace Hopper Door Hinge Seal	3-38
Priming the Fuel System	3-17	Brakes and Tires	3-39
Diesel Fuel Troubleshooting	3-18	Service Brakes	3-39
Cylinder Head	3-19	Parking Brakes	3-40
Cylinder Head	3-19	Tires	3-40
Valve Tappet Clearance	3-19		
Electrical System	3-20	SECTION 4 – APPENDIX	
Battery	3-20	Hardware Information	4-1
Electrical Schematic	3-21	Standard Bolt Torque Chart	4-1
Electrical Schematic, Accessories	3-22	Metric Bolt Torque Chart	4-1
Belts and Chains	3-23	Bolt Identification	4-1
Engine Fan Belt	3-23	Hydraulic Fitting Information	4-2
Static Drag Chain	3-23	Hydraulic Tapered Pipe Fitting (NPT) Torque Chart	4-2
Debris Hopper	3-24	Hydraulic Tapered Seat Fitting (JIC) Torque Chart	4-2
Hopper Dust Filters	3-24	Hydraulic O-Ring Fitting Torque Chart	4-2
To Remove Hopper Dust Filters	3-24		
To Install Hopper Dust Filters	3-25	SECTION 5 – STANDARD MODEL PARTS	
Hopper Fusible Link	3-25		
To Replace Hopper Fusible Link	3-25	SECTION 6 – ACCESSORIES	
Debris Hopper	3-26		
To Check and Adjust Hopper Floor Clearance	3-26	SECTION 7 – HYDRAULIC COMPONENTS	
Stabilizer Leg	3-26		
To Adjust Stabilizer Leg	3-27	SECTION 8 – ENGINE PARTS, DIESEL	
Brushes	3-28		
Main Brush/Wire Brush	3-28	SECTION 9 – CUSTOMER DOCUMENTS	
To Replace Main Brush/Wire Brush	3-28		
To Check and Adjust Main Brush Pattern	3-29		
To Check and Adjust Wire Brush Pattern	3-30		
Side Brush	3-30		
To Replace Side Brush	3-30		
To Adjust Side Brush Maximum Height	3-31		
To Adjust Side Brush Angle	3-31		

SECTION 1 SPECIFICATIONS

CONTENTS

	Page
Machine Specifications	1-1
Machine Dimensions	1-3

MACHINE SPECIFICATIONS

POWER TYPE

Engine type – piston
Ignition – diesel
Cycle – 4
Aspiration – natural
Cylinders – 4
Bore – 3.58 in (91 mm)
Stroke – 4.06 in (103 mm)
Displacement – 164 cu in (2680 cc)
Net power – 51 hp (38 kW) @ 2200 rpm governed
66 hp (49 kW) @ 3000 rpm maximum
Fuels – #1 or #2 diesel fuel, 45 cetane minimum
Cooling system – water
Electrical system – 12 V nominal, 42 A alternator

POWER TRAIN

Propelling – hydraulic drive motor, rear wheel
Main brush – hydraulic drive motor
Side brush – hydraulic drive motor
Vacuum fan – hydraulic drive motor

STEERING

Type – rear wheel controlled, automotive cam and lever
Power source – manual
Emergency steering – manual

HYDRAULIC SYSTEM

Function – operates propelling, hopper lift, hopper dump, main brush drive, main brush pressure, main brush lift, side brush drive, and vacuum fan drive.
Control valve, hopper lift, vacuum fan drive, hopper door – open center, two spool.
Control valve, side brush drive – open center, one spool.
Control valve, main brush speed – open center, one spool.
Control valve, main brush pressure – open center, one spool.
Propelling pump – variable displacement piston pump, 20.8 gpm (80 L/min) @ 2400 rpm
Propelling system rated pressure – 4500 psi (31,030 kPa)
Main brush pump – variable displacement piston pump, 20.8 gpm (80 L/min) @ 2400 rpm
Main brush system rated pressure – 4500 psi (31,030 kPa)
Accessories pump – gear pump, 2 gpm (30 L/min) @ 2400 rpm.
Accessories system rated pressure – 2000 psi (13,790 kPa)
Dump cylinder system rated pressure – 500 psi

(3450 kPa).

Propelling motor – internal gear motor, 29.9 cu in (490 cc) displacement per revolution. 4500 psi (31,030 kPa) maximum rated pressure.
Main brush motor – internal gear motor, 4.9 cu in (80 cc) displacement per revolution. 4500 psi (31,030 kPa) maximum rated pressure.
Side brush motor – internal gear motor, 17.9 cu in (295 cc) displacement per revolution. 2500 psi (17,240 kPa) maximum rated pressure.
Vacuum fan motor – external gear motor, 0.26 cu in (4 cc) displacement per revolution. 3000 psi (20,685 kPa) maximum rated pressure
Hopper lift cylinder – double action, 3.5 in (90 mm) bore x 20.7 in (525 mm) stroke, 1.5 in (40 mm) diameter rod, 2500 psi (17,240 kPa) maximum rated pressure.
Hopper dump cylinder (2) – double action, 2 in (51 mm) bore x 12 in (305 mm) stroke, 1 in (25 mm) diameter rod, 2500 psi (17,240 kPa) maximum rated pressure.
Main brush cylinder (2) – double action, 2.5 in (65 mm) bore x 1.5 in (40 mm) stroke, 1.12 in (30 mm) diameter rod, 2000 psi (13,790 kPa) maximum rated pressure.

BRAKING SYSTEM

Service brakes – hydraulic drum brakes (2), one per front wheel, foot brake master cylinder actuated
Parking brakes – utilizes service brakes, cable actuated

SUSPENSION SYSTEM

Front – two 21 x 5 x 12 solid tires
Rear – one 6.90/6.00 x 9 solid tire

SYSTEM FLUID CAPACITIES

Engine cooling system – radiator 7.4 qt (7 L)
total system 11.2 qt (10.6 L)
Engine lubricating oil – 6 qt (5.7 L) w/o filter
7 qt (6.6 L) w/filter
Fuel tank – 18 gal (68 L)
Hydraulic system – reservoir 12 gal (45.5 L)
total system 14 gal (53 L)

GENERAL MACHINE DIMENSIONS/CAPACITIES

Length – 111.5 in (2830 mm)
Width – 71 in (1805 mm)
Height – 59 in (1500 mm) w/o overhead guard
81.5 in (2070 mm) w/overhead guard
90.5 in (2300 mm) w/overhead guard, revolving light
Track – front, 60.5 in (1535 mm)
Wheel base – 48.9 in (1240 mm)
Main brush, sweeping – diameter, 16 in (405 mm)
length, 50 in (1270 mm)
Main brush, wire – diameter, 15 in (380 mm)
length, 50 in (1270 mm)
Side brush – rotary diameter, 26 in (660 mm)
Sweeping path width – 50 in (1270 mm) w/o side
brush
66 in (1676 mm) w/side brush
Hopper capacity – 1800 lb (815 kg), 26.7 cu ft (0.76
m³)
Dust filter area – 162 sq ft (15 m²)

MACHINE WEIGHTS

Net weight, dry – 5200 lb (2360 kg)
Net GVWR – 7000 lb (3175 kg)

GENERAL MACHINE PERFORMANCE

Maximum forward speed – 10.7 mph (17 km/h)
Maximum reverse speed – 6 mph (10 km/h)
Turning radius – right, 91.5 in (2325 mm) left, 70.75
in (1795 mm)

MACHINE DIMENSIONS

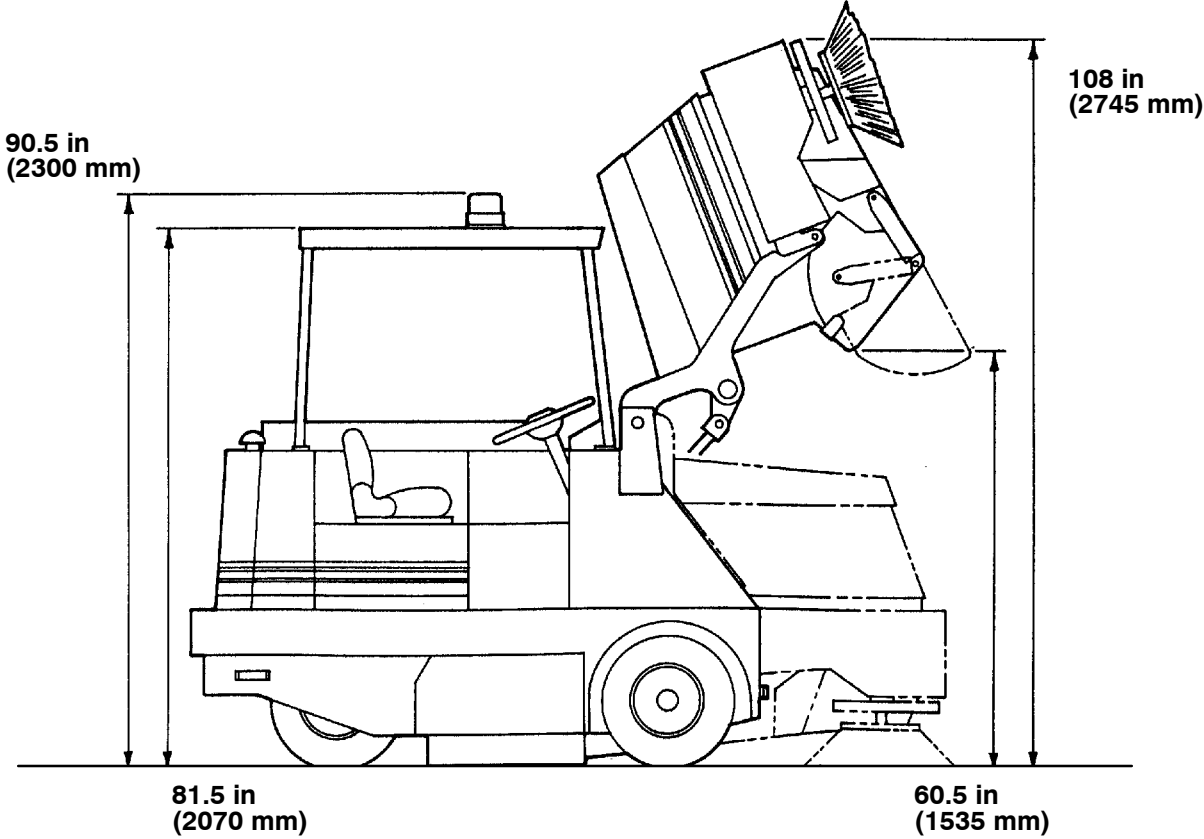
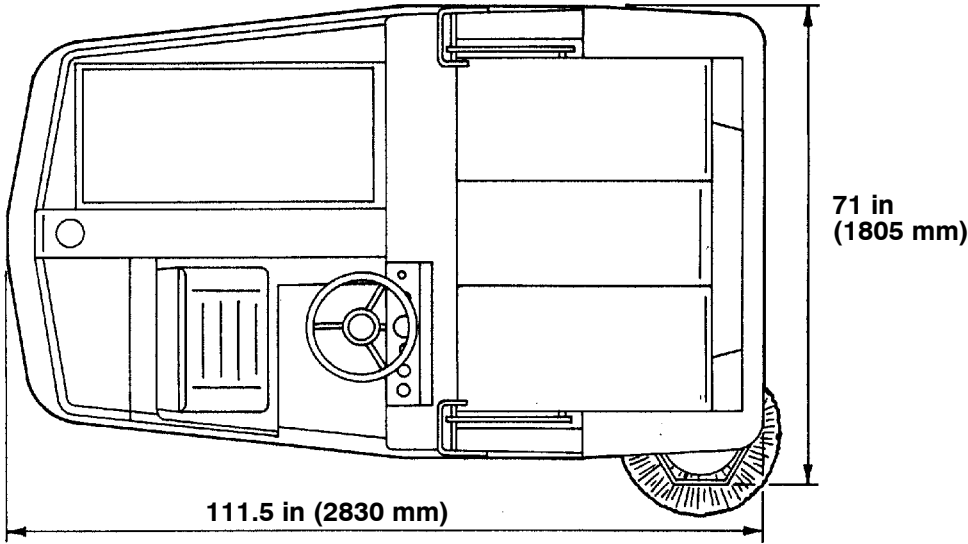

TOP VIEW

SIDE VIEW

01431

SECTION 2 OPERATION

CONTENTS

	Page		Page
Preparation for Operation	2-1	Hydraulic Pressure Gauge	2-10
Operation of Controls	2-2	Stabilizer Leg	2-10
Machine Components	2-2	Fuses and Circuit Breakers	2-10
Controls and Instruments	2-3	Machine Operation	2-11
Brake Pedal	2-4	Normal Sweeping Operation	2-11
Directional Pedal	2-4	Pre-Start Checklist	2-11
Main Brush Height Adjustment		To Start Machine	2-11
Knob	2-4	To Sweep	2-11
Operator Seat	2-4		Page
Main Brush Speed Lever	2-5	To Dump Hopper	2-12
Main Brush Power Lift Lever	2-5	Post Operation Checklist – Engine	
Throttle Lever	2-6	Operating	2-12
Main Brush Pressure Knob	2-6	To Stop Machine	2-12
Side Brush Lever	2-6	Post Operation Checklist – Engine	
Hopper Door Lever	2-6	Stopped	2-13
Vacuum Fan and Hopper Lift		Operation on Grades	2-13
Lever	2-6	Machine Troubleshooting	2-14
Main Brush Lift Lever	2-7	Transporting Machine	2-15
Operating Lamps Switch	2-7	Pushing or Towing Machine	2-15
Hazard Lamp Switch	2-7	Machine Jacking	2-15
Turn Signal Lever	2-7	Machine Tie-Downs	2-16
Clogged Dust Filter Indicator	2-7	Machine Storage	2-17
Dust Filter Shaker Pushbutton		Storing Machine	2-17
Switch	2-7		
Dump Door Indicator	2-7		
Fuel Level Gauge	2-7		
Engine Coolant Temperature			
Gauge	2-7		
Engine Oil Pressure Gauge	2-8		
Steering Wheel	2-8		
Brush Pressure Indicator	2-8		
Battery Condition Gauge	2-8		
Engine Hour Meter	2-8		
Side Brush Switch	2-8		
Diesel Pre-Heat Indicator	2-8		
Ignition Switch	2-8		
Parking Brake	2-8		
Side Brush Height Adjustment Knob	2-9		
Hopper Support Bar	2-9		
To Engage Hopper Support Bar	2-9		
To Disengage Hopper Support			
Bar	2-9		

PREPARATION FOR OPERATION

AFTER UNCRATING AND BEFORE OPERATING THE MACHINE:

1. Check the machine for shipping damage.
2. Read this manual carefully before operating or servicing the machine.



WARNING: Do not operate the machine until you have read and understood the operating instructions and are properly trained. Failure to do so could result in severe personal injury.

3. Check the hydraulic fluid level in the hydraulic fluid reservoir using the sight gauge provided. TENNANT® hydraulic fluid is recommended. If TENNANT® hydraulic fluid is not available, use only new – approved hydraulic fluid. See Hydraulics in the Maintenance section.
4. Check the engine oil level.
5. Check the radiator coolant level.



WARNING: If the coolant is hot or if the engine has been operating, let the engine cool. Hot coolant could scald or cause severe burns. If in doubt, let the coolant cool before releasing pressure in the cooling system.

6. Check the brush adjustment, as described in Maintenance section.
7. Fill the fuel tank.

OPERATION OF CONTROLS

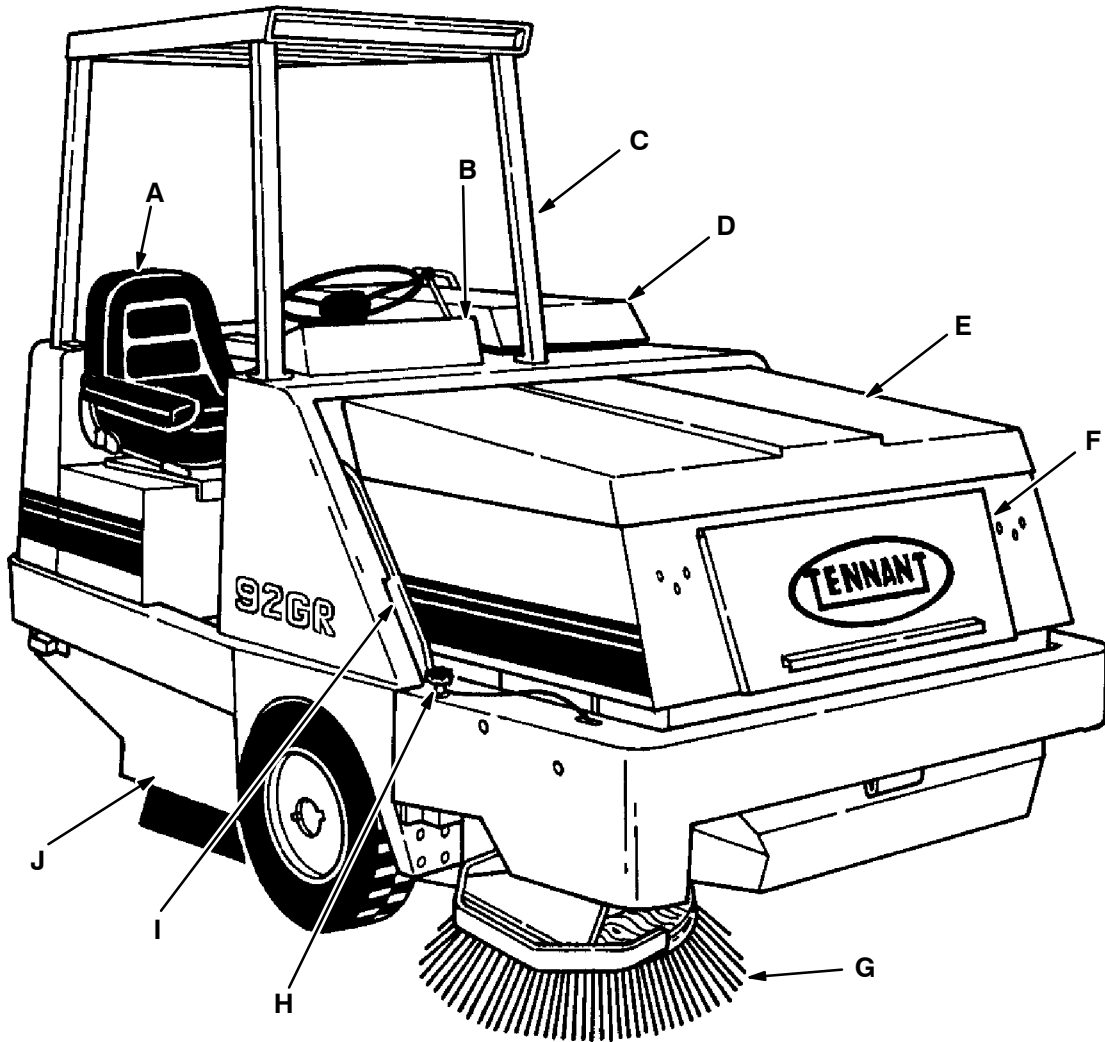

MACHINE COMPONENTS

04300

- | | |
|---------------------|--------------------------------------|
| A. Operator Seat | F. Hopper Inspection Door |
| B. Instrument Panel | G. Side Brush |
| C. Overhead Guard | H. Side Brush Height Adjustment Knob |
| D. Engine Cover | I. Hopper Support Bar |
| E. Hopper | J. Main Brush Access |

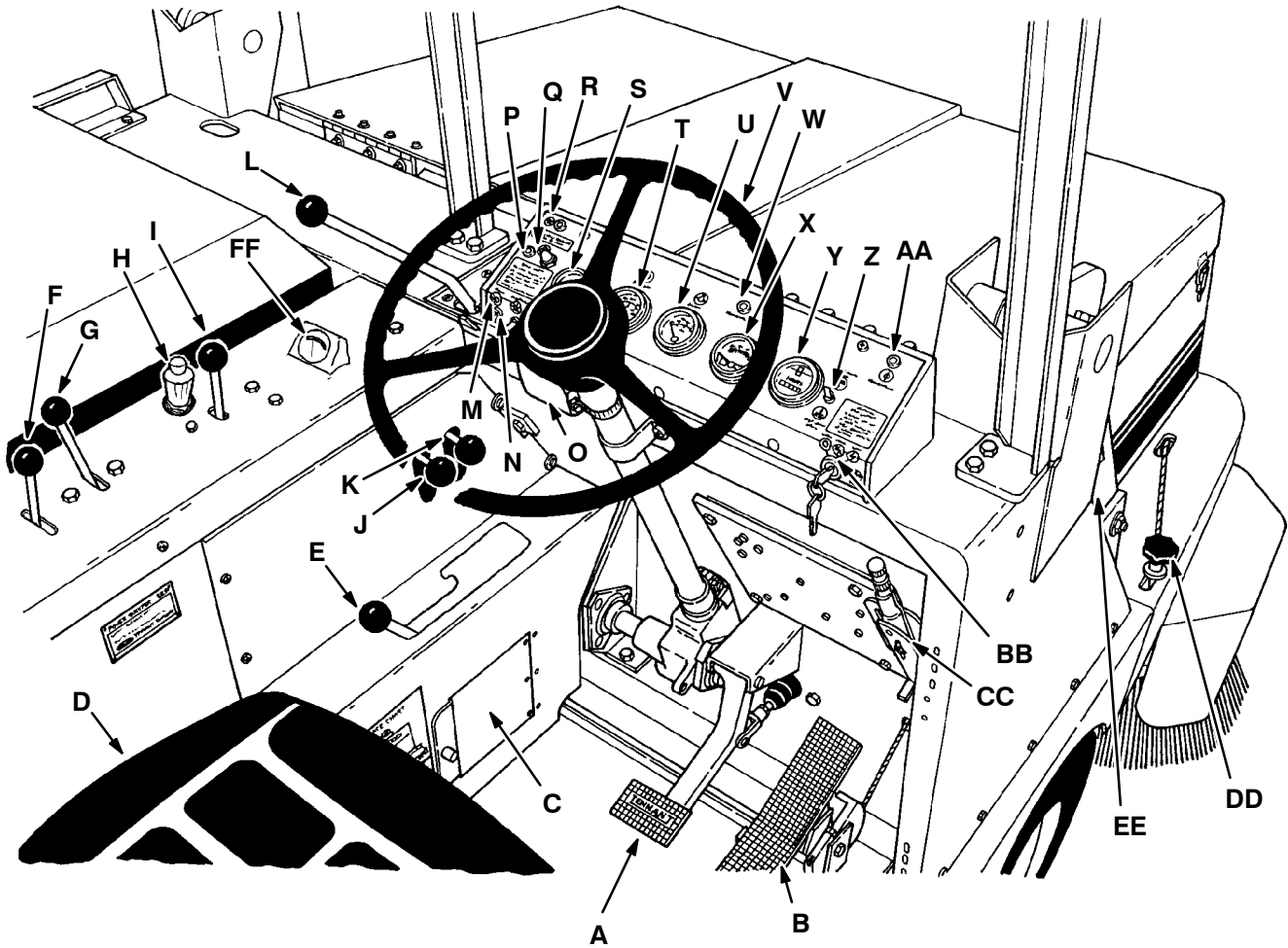

CONTROLS AND INSTRUMENTS

04301

- | | |
|---|--|
| A. Brake Pedal | Q. Dust Filter Shaker Pushbutton Switch |
| B. Directional Pedal | R. Dump Door Indicator |
| C. Main Brush Height Adjustment Knob | S. Fuel Level Gauge |
| D. Operator Seat | T. Engine Coolant Temperature Gauge |
| E. Main Brush Speed Lever | U. Engine Oil Pressure Gauge |
| F. Main Brush Power Lift Lever | V. Steering Wheel |
| G. Throttle Lever | W. Brush Pressure Indicator |
| H. Main Brush Pressure Knob | X. Battery Condition Gauge |
| I. Side Brush Lever | Y. Engine Hour Meter |
| J. Hopper Door Lever | Z. Side Brush Switch |
| K. Vacuum Fan and Hopper Lift Lever | AA. Diesel Preheat Indicator |
| L. Main Brush Lift Lever | BB. Ignition Switch |
| M. Operating Lamps Switch | CC. Parking Brake |
| N. Hazard Lamp Switch | DD. Side Brush Height Adjustment Knob |
| O. Turn Signal Lever | EE. Hopper Support Bar |
| P. Clogged Dust Filter Indicator | FF. Hydraulic Pressure Gauge |

BRAKE PEDAL

The brake pedal operates the mechanical drum brakes on the two front wheels.

To stop the machine, return the directional control pedal to neutral; then apply pressure to the brake pedal.

DIRECTIONAL PEDAL

A single foot pedal controls the hydraulic propelling drive. The foot pedal is used to select the direction of travel and the propelling speed of the machine.

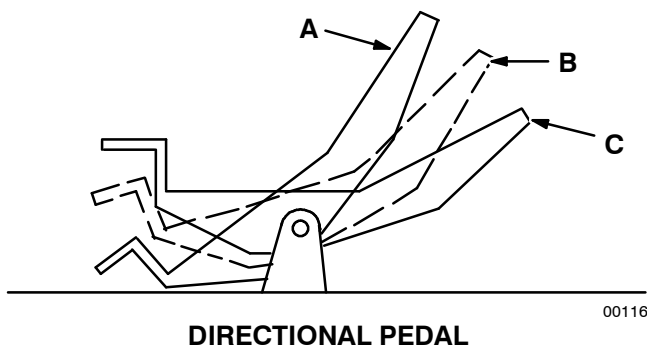

- A. "Reverse" Position
- B. "Neutral" Position
- C. "Forward" Position

Gradually press the "toe" position of the pedal for forward travel or the "heel" portion of the pedal for reverse travel. The propelling speed of the machine is regulated by varying the pressure on the pedal.

If the machine creeps when the pedal is in the neutral position, adjust the pedal as directed in Directional Pedal "Neutral" Position Adjustment in the Maintenance section.

WARNING: Always use the brake pedal for normal stopping and controlling machine speed on downgrades to prevent loss of machine control.

MAIN BRUSH HEIGHT ADJUSTMENT KNOB

The main brush height adjustment knob is located behind an access door next to the operator's left foot. It limits the main brush lift linkage travel. The greater the linkage travel, the greater the amount of floor contact the main brush will have.

Turning the knob clockwise raises the main brush, reducing the main brush floor contact.

Turning the knob counterclockwise lowers the main brush, increasing main brush floor contact.

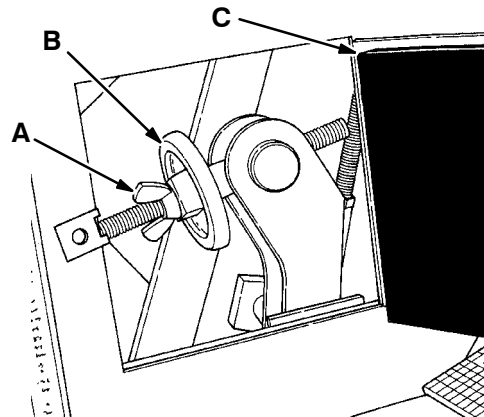

MAIN BRUSH HEIGHT ADJUSTMENT KNOB

- A. Wing Nut
- B. Adjustment Knob
- C. Access Door

OPERATOR SEAT

The operator seat is of a fixed back style.

The seat position is adjusted by pulling the seat position lever to the left, sliding the seat forward or backward to a comfortable position, and releasing the lever.

MAIN BRUSH SPEED LEVER

The main brush speed lever controls the speed of the main brush. It has three positions – “off”, “sweeping”, and “wire brush”.

To start the brushes turning for normal sweeping, push the lever forward into the “sweeping” position.

To start the wire brush turning for grime removal, push the lever forward into the “wire brush” position.

To stop the brush from turning, pull the lever back into the “off” position.

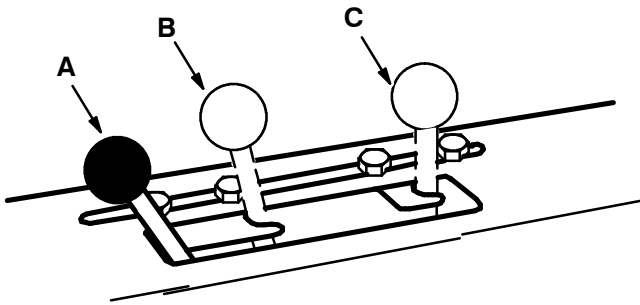

04302

MAIN BRUSH SPEED LEVER

- A. “Off” Position
- B. “Sweeping” Position
- C. “Wire Brush” Position

The main brush power lift lever raises and lowers the wire brush. It has three positions – “up”, “hold”, and “down”.

To raise the wire brush, push the lever into the “up” position. To keep the brush at its present height, pull the lever into the “hold” position.

To lower the brush, pull the lever into the “down” position.

NOTE: The power lift lever will not interfere with the main brush lift lever when it is used to raise a sweeping brush. The main brush lift lever will not lower the brush if the power lift lever is in the “up” or “hold” positions; or if the main brush pressure knob is in the “fully decreased” position.

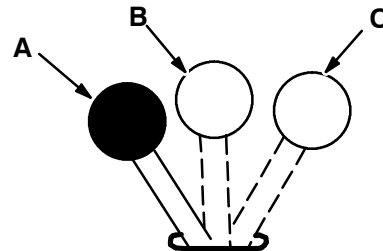

04303

MAIN BRUSH POWER LIFT LEVER

- A. “Up” Position
- B. “Hold” Position
- C. “Down” Position

MAIN BRUSH POWER LIFT LEVER

THROTTLE LEVER

The throttle lever controls the engine governed speed.

Pushing the lever away from the operator speeds the engine to the maximum governed speed.

Pulling the lever back slows the engine to idle speed.

MAIN BRUSH PRESSURE KNOB

The main brush pressure knob controls wire brush down pressure.

To increase down pressure, which lowers the brush, loosen the lock nut and turn the knob counterclockwise. Hand tighten the lock nut. Be aware the lock nut is left-hand threaded. **Do not use a wrench to tighten nut.**

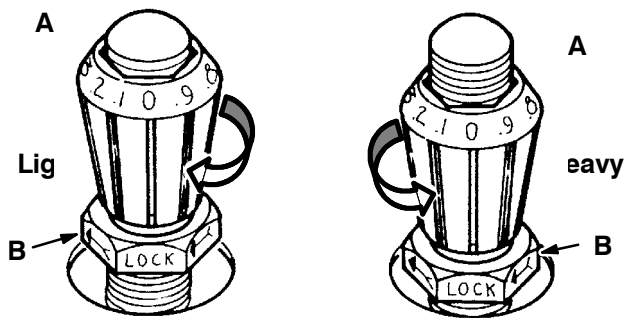

04304

DOWN PRESSURE KNOB SETTINGS

- A. Main Brush Pressure Knob
- B. Lock Nut

To reduce brush down pressure, which raises the brush, loosen the lock nut and turn the knob clockwise. Hand tighten the lock nut. Be aware the lock nut is left-hand threaded. **Do not use a wrench to tighten nut.**

Use the colored bands on the center stem for a reference point when you want to repeat a down pressure setting.

SIDE BRUSH LEVER

The side brush lever operates the side brush control valve which controls the side brush motor.

Pushing the control lever out starts the side brush rotating, provided that the main brush is also operating.

Pulling the control lever back stops the side brush rotation.

NOTE: The side brush will not operate unless the main brush is also operating.

HOPPER DOOR LEVER

The hopper door lever controls the hopper door position.

Pushing the control lever away from the operator into the "open" position, opens the hopper door into the "operating" position.

Pulling the control lever back into the "close" position, closes the hopper door so the hopper may be raised without allowing the debris in the hopper to spill.

Always sweep with the hopper door in the "open" position.

VACUUM FAN AND HOPPER LIFT LEVER

The vacuum fan and hopper lift lever controls vacuum fan and the hopper position.

Pushing the lever down into the "vacuum on" position starts the vacuum fan.

Pulling the lever up slightly into the "raise" position, raises the hopper.

Pulling the lever all of the way into the "hold" position stops the hopper from further raising or lowering.

The center lever position allows the hopper to lower.

WARNING: Always engage the hopper support bar before working under a raised hopper. Do not rely on the machine hydraulic system to keep the hopper in the "raised" position. The hydraulic system may leak internally, allowing the hopper to lower, crushing anything under it.

MAIN BRUSH LIFT LEVER

The main brush lift lever controls the height of the main brush.

Pulling the lever back and to the left lowers the main brush. The main brush may be operated in two positions – “normal” and “free–float.” “Normal” position is used for most sweeping conditions. Operating in the “normal” position will result in much longer main brush life. “Free–float” position is used when extremely uneven areas are encountered. The “free–float” position allows the main brush to follow the uneven surfaces more closely.

Pulling the lever back and to the right into the “raise” position raises the main brush off the floor.

NOTE: Always place the main brush lever in the “raise” position when the machine is to sit unoperated for a period of time to prevent the main brush from taking a set.

NOTE: The power lift lever will not interfere with the main brush lift lever when it is used to raise a sweeping brush. The main brush lift lever will not lower the brush if the power lift lever is in the “up” or “hold” positions; or if the main brush pressure knob is in the “fully decreased” position.

OPERATING LAMPS SWITCH

The operating lamps switch controls the headlamps, taillamps, and the brush spot lamp. Flip the switch toggle upward to turn the lamps on. Flip the switch toggle down to turn the lamps off.

HAZARD LAMP SWITCH

The hazard lamp switch controls the rotating or flashing light. Flip the switch toggle up to turn the lamp on. Flip the switch toggle down to turn the lamp off.

TURN SIGNAL LEVER

The turn signal lever controls the turn signal lights. Pushing the lever forward signals a turn to the right. Pulling the lever back signals a turn to the left.

CLOGGED DUST FILTER INDICATOR

The clogged dust filter indicator lights when the dust filters become clogged and excessively restrict vacuum air flow. Lower the hopper, shut off the main brush and vacuum fan, and push the dust filter shaker pushbutton switch to shake the dust filter. Shake the dust filters when necessary to remove the air restriction. It may be necessary to clean or replace the dust filters to remove the air restriction. Do not continue to sweep with the clogged dust filter indicating lamp lighted as dust pickup will be reduced.

DUST FILTER SHAKER PUSHBUTTON SWITCH

The dust filter shaker pushbutton switch operates the shaker motors which are mounted on top of the hopper dust filters.

To operate the shaker motors, the hopper must be in the operating position. Then place the main brush and hopper lift control lever and side brush control levers in the “off” position. Push the pushbutton switch in to shake the dust filters. The filter shakers will operate for 30 seconds and shut off automatically.

DUMP DOOR INDICATOR

The dump door indicator lights when the hopper dump door is not fully open. The dump door should be fully open and the indicator off whenever debris is being picked up. It should be closed when raising the hopper to dump the debris.

Do not sweep with the dump door indicator lighted.

FUEL LEVEL GAUGE

The fuel level gauge indicates how much fuel is left in the fuel tank.

ENGINE COOLANT TEMPERATURE GAUGE

The engine coolant temperature gauge registers the engine coolant temperature. Normal engine coolant temperatures range up to 200° F (93° C). Temperatures above this level indicate an over–heating engine. This condition may arise due to a low coolant level, a clogged radiator, a loose fan belt, a defective thermostat, or other engine malfunctions. Engine overheating will always cause a coolant loss. If coolant loss does not occur, check for malfunction of the temperature sending unit.

ENGINE OIL PRESSURE GAUGE

This gauge registers the engine oil pressure. Normal engine oil pressure ranges from 7 psi (50 kPa) at idle, to 35 psi (240 kPa) at full engine throttle. If the gauge registers an oil pressure reading below 7 psi (48 kPa), stop the engine immediately and determine the cause. Failure to stop the engine will result in severe engine damage.

STEERING WHEEL

The automotive-type steering wheel operates a steering gear assembly which controls the rear caster wheel through an arm and tie rod arrangement. The machine is very responsive to the movement of the steering wheel. The operator should use care until he or she becomes more experienced in guiding the machine.

BRUSH PRESSURE INDICATOR

The brush pressure indicator light stays on when there is excessive brush down pressure. Under normal main brush conditions, the light should not come on. Under wire brush conditions, the light should flash on and off. When the indicator light stays on, pull back on the main brush lift lever to get the wire brush over high spots on the floor. If the light stays on, reduce brush down pressure by turning the main brush pressure knob clockwise. Watch the hydraulic pressure gauge.

BATTERY CONDITION GAUGE

The battery condition gauge indicates the present voltage potential of the battery. Normal battery voltage is 10 to 14 volts. If the battery voltage exceeds 14 volts, it may be overcharging. If the battery voltage falls below 10 volts, it may not be accepting or getting a charge from the alternator. Overcharging and undercharging are indications that one or more electrical components is in need of repair.

ENGINE HOUR METER

The hour meter records the number of hours the machine has been operated. This information is useful in determining when to service the machine.

SIDE BRUSH SWITCH

The side brush switch operates an electric actuator which controls the side brush position. Placing the switch toggle up in the "up" position, raises the side brush. Placing the switch toggle down in the "down" position, lowers the side brush.

DIESEL PRE-HEAT INDICATOR

The diesel pre-heat indicator lights when the diesel pre-heater is in operation.

IGNITION SWITCH

The key-operated ignition switch has four positions. These positions are: "accessories," "off," "on," and "start."

To start the engine, turn the key clockwise to the "on" position. The diesel pre-heat indicating lamp may light. Wait until the lamp goes off and then turn the key fully clockwise to the "start" position to start the engine. Release the key as soon as the engine starts and the key will place itself in the "on" position.

NOTE: The diesel pre-heater stops when the ignition key is advanced past the "on" position. To reactivate the diesel pre-heater, the key must be turned back to the "off" position to reset the pre-heat solenoid.

NOTE: Do not engage the starter for more than ten seconds at a time, or after the engine has started, as the starter may be damaged.

PARKING BRAKE

The parking brake controls two brake cables which are connected to the mechanical drum brakes on the two front wheels. Pulling the brake handle up engages the parking brake.

Pushing the brake handle to the left and down releases the parking brake. Always engage the parking brake before leaving the machine unattended and before working on the machine.

SIDE BRUSH HEIGHT ADJUSTMENT KNOB

The side brush height adjustment knob is located just above the side brush on the front bumper. It controls the height of the side brush.

Loosening the knob and sliding it forward lowers the side brush, sliding it backward raises the side brush. Tighten the knob after setting the side brush height. The side brush should be in the “raised” position before making an adjustment.

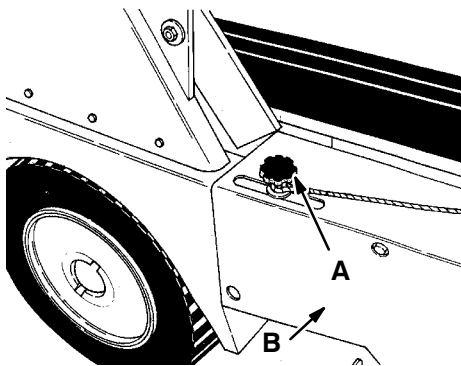

SIDE BRUSH HEIGHT ADJUSTMENT KNOB

- A. Adjustment Knob
- B. Side Bumper

01441

HOPPER SUPPORT BAR

The hopper support bar is located on the operator's side of the hopper. It holds the hopper up when work is to be done under the hopper. Do not rely on the machine hydraulic system to keep the hopper raised.

WARNING: Always engage the hopper support bar before working under a raised hopper. Do not rely on the machine hydraulic system to keep the hopper in the “raised” position. The hydraulic system may leak internally, allowing the hopper to lower, crushing anything under it.

TO ENGAGE HOPPER SUPPORT BAR

1. Engage the machine parking brake.

WARNING: Always park on a level surface and engage the machine parking brake before working on the machine to keep it from rolling.

2. Raise the hopper to the fully raised position.
3. Position the hopper support bar under the hopper lift arm cam.

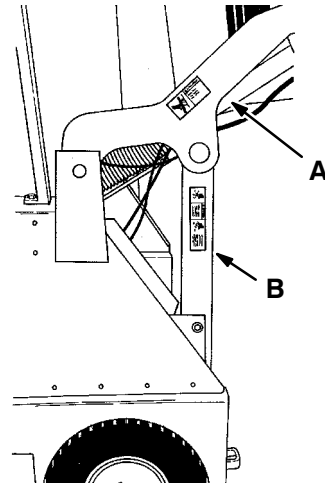

ENGAGED HOPPER BAR

- A. Lift Arm
- B. Hopper Support Bar

01438

4. Slowly lower the hopper so the lift arm cam seats itself on top of the hopper support bar.
5. Turn the engine off.
6. Check the hopper support bar to make sure it is securely engaged.

TO DISENGAGE HOPPER SUPPORT BAR

1. Start the engine.
2. Place the engine throttle lever in the “fast” position.
3. Raise the hopper to the fully raised position.
4. Lower the hopper support bar to its storage location.

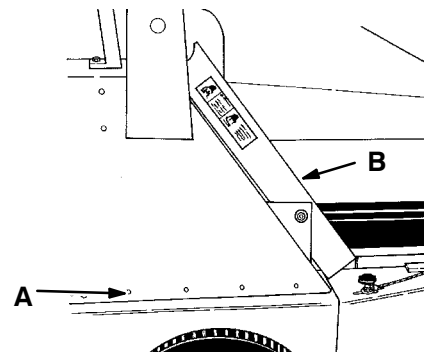

DISENGAGED HOPPER SUPPORT BAR

- A. Machine Frame
- B. Hopper Support Bar

01439

5. Lower the hopper.

HYDRAULIC PRESSURE GAUGE

The hydraulic pressure gauge registers the hydraulic pressure in the main brush circuit. Normal down pressure ranges with the brush up and running are 300 to 500 psi (2070 to 3450 kPa) and from 1800 to 2200 psi (12,410 to 15,170 kPa) with the brush down and running. It is normal for the gauge needle to move around. It moves around due to uneven or high spots in the floor.

Prolonged pressures above 2250 psi (15,510 kPa) will cause the wire brush to stall and will damage the brush and hydraulic system.

STABILIZER LEG

The stabilizer leg projects forward to act as an anti-tipping device when the machine is being high dumped. Check the stabilizer leg to be sure it is projecting forward when the machine is being high dumped and is fully retracted when the hopper is in the "operating" position.

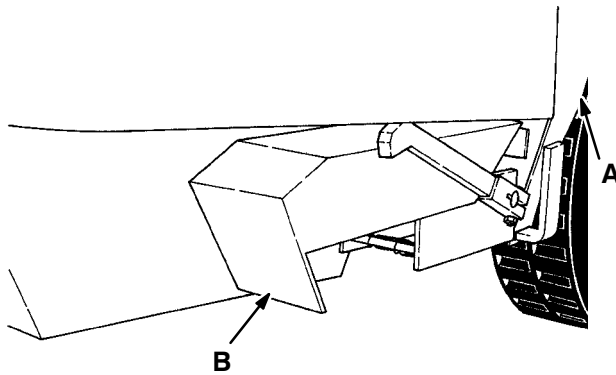

01440

RETRACTED STABILIZER LEG

- A. Machine Frame**
- B. Stabilizer Leg**

FUSES AND CIRCUIT BREAKERS

Fuses are a one-time circuit protection device designed to stop the flow of current in the event of a circuit overload. Never substitute higher value fuses than those specified in this manual.

Circuit breakers are reusable circuit protection devices designed to stop the flow of current in the event of a circuit overload. Once tripped, circuit breakers must cool before they automatically reset.

If the overload which caused the circuit breaker to trip is still present in the circuit, the circuit breaker will continue to stop current flow until the overload is corrected. The chart below shows the various fuses and circuit breakers, the electrical components they protect, and their locations in the machine.

PROTECTIVE DEVICE	CIRCUIT RATING	PROTECTED	LOCATION
FU-1	50 A	Diesel Glow Plug	Diesel Control Unit
CB-1	25 A	Dust Shaker Motors	Electric Breaker Box
CB-2	15 A	Operating Lamps	Electric Breaker Box
CB-3	15 A	Gauges	Electric Breaker Box
CB-4	15 A	Actuator	Electric Breaker Box
CB-5	15 A	Turn Signal Lamps	Electric Breaker Box
CB-6	15 A	Heater, Defroster, Fan	Electric Breaker Box
CB-7	15 A	Back-up Alarm	Electric Breaker Box

MACHINE OPERATION

NORMAL SWEEPING OPERATION

A normal sweeping operation consists of seven typical operations: pre–start checklist, starting machine, sweeping, dumping hopper, post operation checklist – – engine operating, stopping machine, and post operation checklist – – engine stopped.

The Pre–Start Checklist lists things to check before starting the machine.

To Start Machine lists the steps required to start the machine.

To Sweep lists things to keep in mind before and during the sweeping operation.

To Dump Hopper lists the steps required to dump the hopper.

Post Operation Checklist – – Engine Operating lists things to check before stopping the machine engine.

To Stop Machine lists the steps required to stop the machine.

Post Operation Checklist – – Engine Stopped lists things to check after stopping the machine engine.

PRE–START CHECKLIST

Check under machine for leak spots.
Check engine lubricating oil level.
Check fuel level.
Check brakes and controls for proper operation.
Check service records to determine service requirements.

TO START MACHINE

NOTE: Before starting machine, perform the pre–start checks.

1. The machine operator must be in the operator’s seat with the directional control pedal in the “neutral” position and with a foot on the brake pedal or with the parking brake engaged.

 **WARNING:** Before operating the machine, make sure all safety devices are in place and operate properly. Check the foot and parking brakes and the steering control for proper operation. Do not start the machine unless you are in the operator’s seat with a foot on the brake pedal or have the parking brake engaged and the directional control pedal in the “neutral” position. Failure to do so could result in severe personal injury.

2. Move the throttle control lever to the “full” position.
3. Turn the ignition key clockwise to the “on” position. The diesel pre–heat indicating lamp may light. Wait until the lamp goes off and then turn the key fully clockwise to the “start” position to start the engine. Release the key as soon as the engine starts and the key will place itself in the “on” position.

NOTE: The diesel pre–heater stops when the ignition key is advanced past the “on” position. To reactivate the diesel pre–heater, the key must be turned back to the “off” position to reset the pre–heat solenoid.

NOTE: Do not operate the starter motor for more than 10 seconds at a time or after the engine has started. Allow the starter to cool between starting attempts. The starter motor may be damaged if it is operated incorrectly.

4. Allow the engine and hydraulic system to warm up three to five minutes.
5. Disengage the machine parking brake.
6. Drive the machine to the area to be swept.

TO SWEEP

Plan the sweeping in advance. Try to arrange long runs with minimum stopping and starting. Sweep debris from very narrow aisles into main aisles ahead of time. Do an entire floor or section at one time.

Pick up oversize debris before sweeping. Flatten or remove bulky cartons from aisles before sweeping. Pick up pieces of wire, twine, string, etc., which could become entangled in brush or brush plugs. Overlap brush paths.

Avoid turning the steering wheel too sharply when the machine is in motion. The machine is very responsive to the movement of the steering wheel. Avoid sudden turns, except in emergencies.

Sweep as straight a path as possible. Avoid bumping into posts or scraping the sides of the sweeper.

When using the wire brush, if the brush pressure indicator light stays on due to a high concentration of grime or uneven floor, pull the main brush lift lever back to assist brush to climb over the area to relieve stress on the hydraulic system.

1. Push the side brush lever into the “on” position.
2. Push the main brush speed lever into the “sweeping” or “wire brush” position depending on your main brush.
3. Move the main brush power lift lever into the “down” position.
4. Move the main brush lift lever into the “normal” position and the side brush position switch into the “down” position.
5. Push the vacuum fan and hopper lift lever into the “vacuum on” position.
6. Adjust the main brush pressure knob to suit the floor conditions.
7. Sweep as required.

TO DUMP HOPPER

1. Pull the main brush lift lever back into the “raise” position.
2. Press the side brush position switch back into the “up” position.
3. Move the main brush power lift lever into the “up” position.
4. Move the main brush speed lever into the “off” position.

5. Move the side brush lever into the “off” position.
6. Press the filter shaker switch to shake the dust filters.
7. Slowly drive the machine up to the dump site or dumpster.
8. Pull the hopper lift lever up into the “raise” position to lift the hopper to the desired height. Be aware: The minimum hopper clearance needed to high dump the hopper is 108 in (2745 mm).



WARNING: Be sure adequate overhead clearance is available before attempting to high dump the hopper to avoid falling objects or electrical shock hazards.

Pull the lever up into the “hold” position to keep the hopper at the desired height; then push the hopper door lever into the “dump” position to dump the hopper.

NOTE: Lowering the hopper into the dumpster may help to control flying dust.

Pull the hopper door lever into the “return” position to return the hopper door to its normal angle, then release lever.

9. Slowly back the machine away from the dump site or dumpster.
10. Push the hopper lift lever into the “lower” position to return the hopper to its “operating” position.

POST OPERATION CHECKLIST – ENGINE OPERATING

Check brush patterns for width and taper.

TO STOP MACHINE

1. Return the directional control pedal to the “neutral” position. Apply the brake.
2. Pull the main brush lift lever back into the “raise” position.
3. Press the side brush position switch back into the “up” position.

4. Move the main brush power lift lever into the “up” position.
5. Move the main brush speed lever into the “off” position.
6. Move the side brush lever into the “off” position.
7. Turn the operating lamps off if used.
8. Place the throttle lever in the “idle” position.
9. Engage the machine parking brake.
10. Turn the ignition switch key to the “off” position. Remove the key from the switch.

 **WARNING: Always park on a level surface, stop the engine, and engage the parking brake before leaving the machine unattended to keep it from creeping or rolling.**

POST OPERATION CHECKLIST – ENGINE STOPPED

Check skirts for damage, wear, and adjustment.
Check for wire or string tangled on brushes.
Check for leaks.

OPERATION ON GRADES

Drive the machine slowly on grades. Use the service brakes to control machine speed.

 **WARNING: Always travel slowly on grades to prevent machine from becoming unstable. When going down a grade, use service brakes to control speed. Do not operate machine on greater than maximum rated climb and descent angles.**

The maximum rated ramp climb and descent angle is 15° with an empty hopper, and 12° with a full hopper.

MACHINE TROUBLESHOOTING

Problem	Cause	Remedy
Excessive dusting	Dust skirts and seals worn, damaged, not adjusted properly	Replace or adjust skirts or seals
	Dust filter clogged	Shake and/or clean or replace filter
	Vacuum hose damaged	Replace vacuum hose
	Vacuum fan failure	See Hydraulic System Troubleshooting: Poor or no vacuum to brush compartment
Poor sweeping performance	Brush bristles worn	Replace brushes
	Brushes not adjusted properly	Adjust brushes
	Debris caught in brush	Free mechanism of debris drive mechanism
	Main brush drive failure	See Hydraulic System Trouble-shooting: Main brush turns slowly or not at all
	Side brush drive failure	See Hydraulic System Trouble-shooting: Side brush turns slowly or not at all
	Hopper not adjusted properly	Adjust hopper floor clearance
	Hopper full	Empty hopper
	Hopper floor skirts worn, damaged	Replace skirts

NOTE: For more specific electro-hydraulic system troubleshooting information, see Hydraulic System Troubleshooting in the Maintenance section.

TRANSPORTING MACHINE

PUSHING OR TOWING MACHINE

The machine may be pushed from the front or the rear, using the bumpers provided, only after placing the rear wheel on a dolly.

The machine may be towed only from the rear. Do not pull on the front bumper.

ATTENTION! Do not push or tow the machine without placing the rear wheel on a dolly or the machine hydraulic system may be damaged.

MACHINE JACKING

1. Stop the engine and engage the machine parking brake.

! WARNING: Always stop the machine on a level surface, stop the engine and engage the parking brake before working on the machine to keep it from rolling.

2. Empty the debris hopper before attempting to jack the machine up.
3. Block the tires which are not being jacked up to secure the machine's position.

! WARNING: Always block the machine tires before jacking the machine up to keep it from rolling off jack.

4. Use a scissors or hydraulic-type jack of adequate capacity to raise the machine. Jack up the machine only at the designated locations.

! WARNING: Jack machine up only at the designated locations to keep it from tipping.

The front jacking locations are the bottom edge of the machine frame next to the front machine tires.

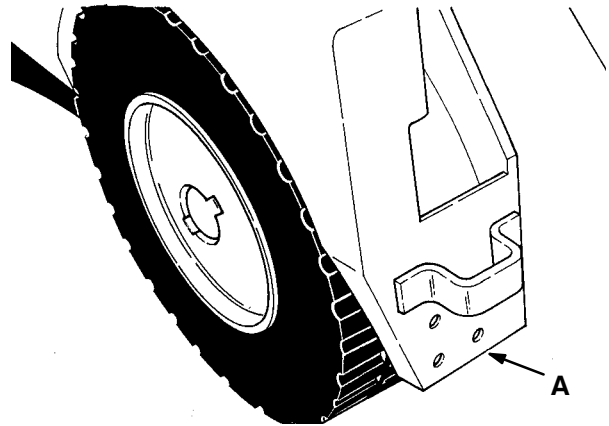

01455
FRONT JACKING LOCATION (RIGHT SIDE SHOWN)

A. Jacking Location

The rear jacking location is the bottom of the rear edge of the machine frame.

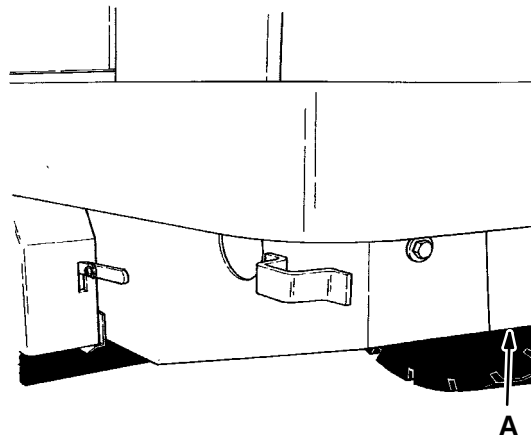

01456
REAR JACKING LOCATION

A. Jacking Location

5. Block machine up with jack stands or similar devices to make sure machine is secure.

! WARNING: Always use jack stands or similar devices to hold the machine up. Scissors, ratchet, cable, or hydraulic-type jacks may slip or leak internally allowing the machine to lower or fall, crushing anything under it.

6. Lower the machine onto the jack stands.
7. Check to make sure the machine is secure.
8. Service the machine as required.
9. When finished servicing the machine, raise the machine up off the jack stands.
10. Remove the jack stands from under the machine.
11. Lower the machine.
12. Remove the blocks from the tires.

MACHINE TIE-DOWNS

The machine may be tied down at each of the four corners of the machine at the locations specified.

To tie the machine down, use the tie down lug provided.

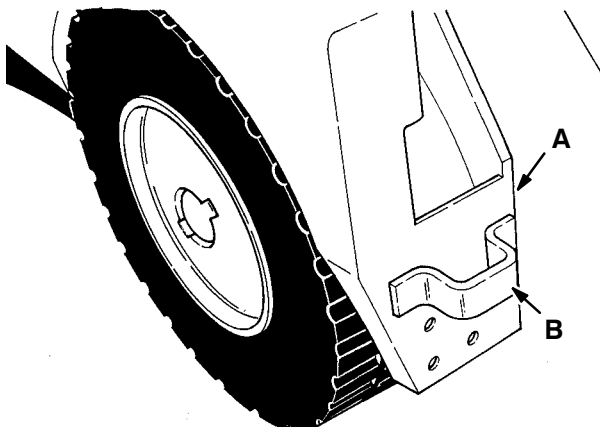

FRONT TIE-DOWN LUG (RIGHT SIDE SHOWN)

- A. Machine Frame**
- B. Tie-Down Lug**

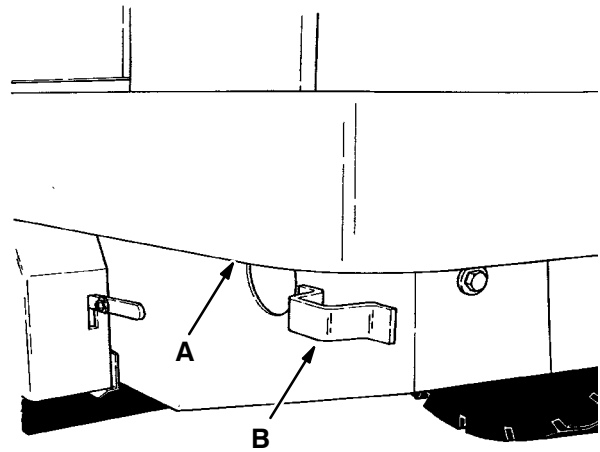

REAR TIE-DOWN LUG (LEFT SIDE SHOWN)

- A. Machine Frame**
- B. Tie-Down Lug**

When transporting the machine on a trailer or in a truck, be sure to engage the machine parking brake and block the machine tires to prevent the machine from rolling.

MACHINE STORAGE

STORING MACHINE

When storing the machine for extended periods of time, the following procedures must be followed to lessen the chance of rust, sludge, and other undesirable deposits from forming.

1. Empty the debris hopper.
2. Change engine oil.
3. Place the main brush height control lever in the “raise” position.
4. Park the machine in a cool and dry area.
5. Stop the engine.
6. Fill the hydraulic reservoir with hydraulic fluid to the full mark on the sight gauge to prevent excessive condensation from forming in the reservoir.

SECTION 3 MAINTENANCE

CONTENTS

	Page		Page
Recommended First 50–Hour Machine		Belts and Chains	3–23
Inspection	3–1	Engine Fan Belt	3–23
Maintenance Chart	3–2	Static Drag Chain	3–23
Lubrication	3–4	Debris Hopper	3–24
Engine	3–4	Hopper Dust Filters	3–24
Rear Wheel Support Pivot	3–4	To Remove Hopper Dust Filters	3–24
Steering Gear	3–4	To Install Hopper Dust Filters	3–25
Side Brush Pivot Pins	3–5	Hopper Fusible Link	3–25
Stabilizer Leg Pivot Pin	3–5	To Replace Hopper Fusible Link	3–25
Front Wheel Bearings	3–5	Debris Hopper	3–26
Hydraulics	3–6	To Check and Adjust Hopper	
Hydraulic Fluid	3–6	Floor Clearance	3–26
Hydraulic Fluid Reservoir	3–6	Stabilizer Leg	3–26
Hydraulic Fluid Filter	3–7	To Adjust Stabilizer Leg	3–27
To Replace the Hydraulic		Brushes	3–28
Fluid Filter Element	3–7	Main Brush/Wire Brush	3–28
Directional Control Pedal “Neutral”		To Replace Main Brush/Wire	
Position Adjustment	3–7	Brush	3–28
Speed Limiter	3–8	To Check and Adjust Main	
Hydraulic Fluid Leaks	3–8	Brush Pattern	3–29
Hydraulic Schematic	3–9	To Check and Adjust Wire	
Hydraulic System Troubleshooting	3–10	Brush Pattern	3–30
Hydraulic Components		Side Brush	3–30
Troubleshooting	3–12	To Replace Side Brush	3–30
Engine	3–13	To Adjust Side Brush	
Engine Lubrication	3–13	Maximum Height	3–31
Cooling System	3–13	To Adjust Side Brush Angle	3–31
Air Intake System	3–13	To Adjust Side Brush Bumper	
Air Filter Restriction Indicator	3–14	Clearance	3–32
Air Filter	3–14	Skirts and Seals	3–33
To Replace Air Filter Element	3–14	Hopper Lip Skirts	3–33
Fuel System – Diesel	3–15	To Replace Hopper Lip Skirts	3–33
Diesel Fuel System	3–15	Hopper Side Seals	3–33
Fuel Water Trap	3–15	To Replace Hopper Side Seals	3–33
To Clean Water Trap	3–15	Brush Door Skirts	3–34
Fuel Filter	3–16	To Replace and Adjust Brush	
To Replace Fuel Filter		Door Skirts	3–34
Element	3–16	Rear Skirts	3–35
Fuel Injection Pump	3–16	To Replace and Adjust Rear	
Fuel Injectors	3–16	Skirts	3–35
Priming the Fuel System	3–17	Hopper Dust Dump Door Seal	3–35
Diesel Fuel Troubleshooting	3–18	To Replace Hopper Dust Dump	
Cylinder Head	3–19	Door Seal	3–35
Cylinder Head	3–19	To Check and Adjust Hopper	
Valve Tappet Clearance	3–19	Dust Dump Door Seal	3–36
Electrical System	3–20	Hinged Top Hopper Seal	3–37
Battery	3–20	To Replace and Adjust Hinged	
Electrical Schematic	3–21	Top Hopper Seal	3–37
Electrical Schematic, Accessories	3–22	Hopper Door Hinge Seal	3–38

	Page
To Replace Hopper Door Hinge	
Seal	3-38
Brakes and Tires	3-39
Service Brakes	3-39
Parking Brakes	3-40
Tires	3-40

RECOMMENDED FIRST 50–HOUR MACHINE INSPECTION

After the first 50 hours of operation, the following procedures are recommended:

1. Check the brush pattern for correct brush adjustment.
2. Change the hydraulic fluid filter.
3. Check the torque of the engine cylinder head cap screws.
4. Perform all 50–hour interval lubrication and maintenance procedures listed in the Maintenance chart.
5. Check the valve tappet clearance after the first 250 hours of operation.

MAINTENANCE CHART

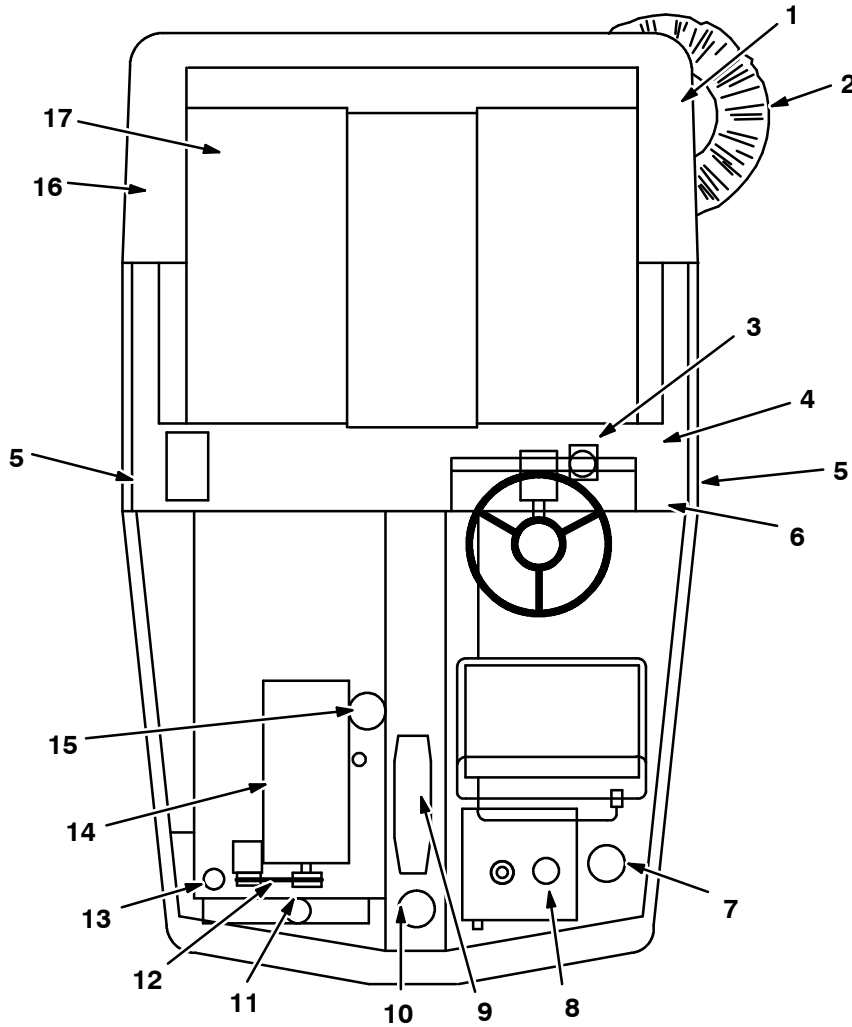

MAINTENANCE LOCATIONS

04305

MAINTENANCE CHART

Interval	Key	Description	Procedure	Lubricant	No. of Service Points
Daily	10	Air filter restriction indicator	Check for restriction indicator	–	1
	14	Engine	Check oil level	EO	1
	13	Fuel water trap	Drain water	–	1
	5	Brush skirts	Check for damage wear, and adjustment	–	9
	2	Side brush	Check for damage, wear, and adjustment	–	1
	4	Main brush	Check for damage, wear, and adjustment	–	1
50 Hours	12	Engine fan belt	Check tension	–	1
	14	Engine crankcase	Change oil and filter	EO	1
	17	Hopper	Check floor clearance	–	1
	4	Main brush	Rotate end–for–end and check adjustment	–	1
100 Hours	6	Parking brake	Check adjustment	–	1
	11	Radiator	Check coolant level Check core exterior for debris and clean	WG –	1 1
	8	Hydraulic fluid reservoir	Check fluid level	HYDO	1
	17	Hopper dust filter	Inspect, clean, or replace	–	2
	5	Dust seals	Check for damage or wear	–	5
	13	Fuel water trap	Clean	–	1
	200 Hours	16	Stabilizer leg pivot pin	Lubricate	MPGM
1		Side brush pivot pins	Lubricate	MPGM	5
9		Rear wheel support pivot	Lubricate	MPGM	1
400 Hours	15	Fuel filter	Replace	–	2
	14	Engine	Adjust valve tappets	–	8
	8	Hydraulic fluid reservoir	Change hydraulic fluid	HYDO	1
	7	Hydraulic fluid filter	Change filter element	–	1
	3	Brake master cylinder	Check fluid level	BF	1
800 Hours	8	Hydraulic reservoir strainer	Replace	–	1
	11	Cooling system	Flush	WG	1

BF – Brake fluid

EO – Engine oil

HYDO – Tennant Company or approved hydraulic fluid

MPGM – Multipurpose, water resistant, lithium base, moly–disulphide EP grease

WG – Water and permanent–type ethylene glycol anti–freeze, one–to–one ratio

NOTE: More frequent intervals may be required in extremely dusty conditions.

LUBRICATION

ENGINE

Check the engine oil level daily. Change the engine oil and oil filter after every 50 hours of operation. Change the engine oil more frequently if the environment is extremely dusty. Use only CD or CE rated engine oil.

The following SAE oil grades are general recommendations for engines during the changing seasonal temperatures.

BELOW 0°F (BELOW -17°C)	0+ to 32°F (-17+ to 0°C)	32+ to 75°F (0+ to 24°C)	ABOVE 75°F (ABOVE 24°C)
SAE 5W	SAE 10W	SAE20W	SAE 30
SAE 5W-20	SAE 10W-30	SAE 10W-30	SAE 10W-30
SAE 5W-30	SAE 10W-40	SAE 10W-40	SAE 10W-40

Multi-grade oil should cover the single grade recommendation for the temperatures involved. The engine oil capacity is 7 qt (6.6 L) with filter.

REAR WHEEL SUPPORT PIVOT

There is a grease fitting which is used to lubricate the rear wheel support pivot bearing.

Access to the grease fitting is through the center rear access door. Apply a general purpose, water resistant, lithium base, moly-disulphide EP grease after every 200 hours of operation.

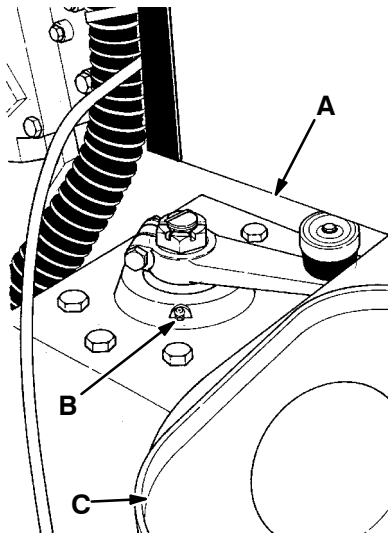

REAR WHEEL SUPPORT PIVOT

- A. Wheel Support
- B. Grease Fitting
- C. Fuel Tank

01452

STEERING GEAR

The steering gear has been lubricated at the factory and should not require any additional lubricant unless a massive leak occurs.

A square head plug located on the left side of the steering gearbox is provided to fill the steering gear with grease if necessary.

The proper lubricant is grade 1 calcium soap base EP grease.

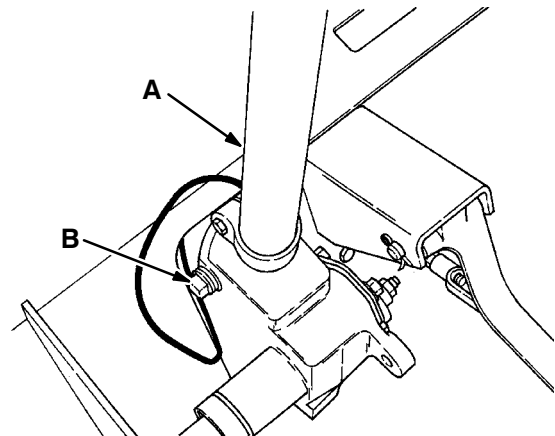

STEERING GEAR LUBRICATION PLUG

- A. Steering Gearbox
- B. Fill Plug

01457

SIDE BRUSH PIVOT PINS

The five side brush pivot pins should be lubricated with a general purpose, water resistant, lithium base, moly–disulphide EP grease after every 200 hours of operation.

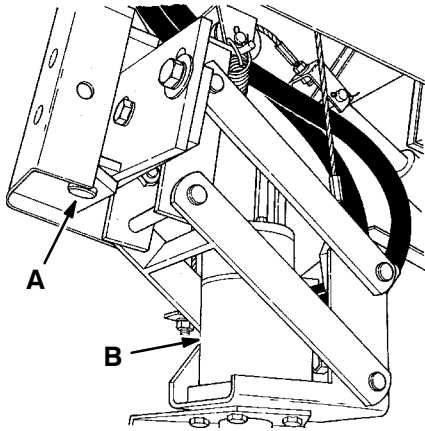

01459

SIDE BRUSH PIVOT PINS

- A. Pivot Pin
- B. Side Brush Motor

STABILIZER LEG PIVOT PIN

The stabilizer leg pivot pin should be lubricated with a general purpose, water resistant, lithium base, moly–disulphide EP grease after every 200 hours of operation.

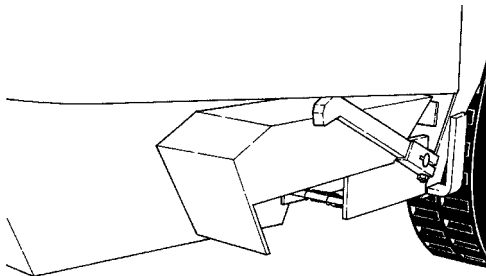

01440

STABILIZER LEG

FRONT WHEEL BEARINGS

The front wheel bearings should be repacked with a good quality wheel bearing grease after every 2000 hours of operation.

HYDRAULICS

HYDRAULIC FLUID

Hydraulic fluid drives most of the moving components of the machine. The quality and condition of the hydraulic fluid play a very important role in how well the machine operates. Tennant Company has developed its own hydraulic fluid to meet the special needs of its machines.

TENNANT Hydraulic Fluid is a specially compounded oil with the following features not found in many hydraulic fluids:

1. Flat viscosity curve.
2. Additives to prevent corrosion.
3. Additives to prevent oxidation.
4. Rust inhibitors.
5. Foam suppressors.

These features restrict foaming of the hydraulic fluid and provide a high standard of lubrication to the components.

TENNANT® HYDRAULIC FLUID VISCOSITY SPECIFICATIONS

		TENNANT® Hyd. Fluid No. 32397 (HP1040)	TENNANT® Hyd. Fluid No. 32398 (HP2060)
SUS @ 100°	F (38° C)	404–445	940–1010
SUS @ 210°	F (99° C)	78–84	122–130

TENNANT Hydraulic Fluids have a very flat viscosity curve (synonymous with “high viscosity index”). The flat viscosity curve means that the thickness of the fluid is very constant over wide temperature ranges.

Hydraulic fluid with the viscosity rating of 10W40 should be used in machines that are operated in areas which have ambient temperatures up to 90° (32° C). Use the 20W60 rated hydraulic fluid in areas which have ambient temperatures above 90° (32° C).

ATTENTION! If a locally–available hydraulic fluid is preferred, or if products of only one oil company are used, the hydraulic fluid used must match closely the viscosity specifications given in the chart for TENNANT Hydraulic Fluid, as well as the other features described. Do not substitute automatic transmission fluid for hydraulic fluid.

ATTENTION! Hydraulic components depend on

3-65542

system hydraulic fluid for internal lubrication. If dirt or other contaminants are allowed to enter the hydraulic system, malfunctions, accelerated wear, and damage will result.

HYDRAULIC FLUID RESERVOIR

Hydraulic fluid is stored in the hydraulic fluid reservoir. The reservoir holds up to 12 gal (45.5 L) of hydraulic fluid. The reservoir is located behind the operator seat.

The reservoir is equipped with a breather–filler cap and a sight gauge. The breather–filler cap requires no regular maintenance.

The reservoir is also equipped with a fluid level sight gauge. It is located on the side of the hydraulic fluid reservoir. The sight gauge indicates the level of hydraulic fluid in the reservoir. Check the hydraulic fluid level after every 100 hours of operation.

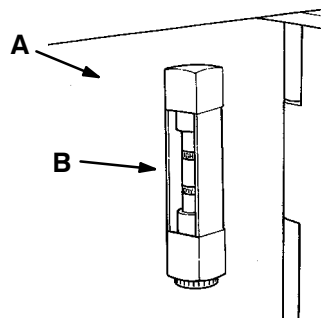

HYDRAULIC FLUID RESERVOIR

- A. Hydraulic Fluid Reservoir
- B. Sight Gauge

Do not overfill the hydraulic fluid reservoir. When the fluid is cold, the fluid should just appear on the bottom of the sight gauge. The hydraulic fluid expands as it heats up to its normal operating temperature. Always allow for this expansion when filling the hydraulic fluid reservoir.

ATTENTION! Do not overfill the hydraulic fluid reservoir or operate the machine with a low level of hydraulic fluid in the reservoir. Either one may cause damage to the machine hydraulic system.

Change the hydraulic fluid after every 400 hours of operation.

00005

HYDRAULIC FLUID FILTER

The machine hydraulic system is kept clean to a level of 10 microns by a hydraulic fluid filter. The hydraulic fluid filter is located on the right side of the hydraulic fluid reservoir.

Replace the hydraulic fluid filter element after the first 50 hours of operation and then after every 400 hours of operation.

TO REPLACE THE HYDRAULIC FLUID FILTER ELEMENT

1. Stop the engine and engage the machine parking brake.

 **WARNING: Always stop the machine on a level surface, stop the engine and engage the parking brake before working on the machine to keep it from rolling.**

2. Open the right rear access door.
3. Unthread and remove the hydraulic fluid filter element case. Remove and discard the filter element.

NOTE: Discard all hydraulic fluid drained from the system. Drained hydraulic fluid may contain foreign material harmful to the hydraulic system.

4. Apply a thin coat of hydraulic fluid to the seal of the new hydraulic fluid filter element. Place it into the filter case.
5. Thread the hydraulic fluid filter case on the filter head.
6. Operate the machine and check for leaks. Correct any leaks found.
7. Check the hydraulic fluid reservoir level and fill as required.

DIRECTIONAL CONTROL PEDAL “NEUTRAL” POSITION ADJUSTMENT

After replacing the hydraulic pump or pump linkages, the pump control linkages must be adjusted.

1. Stop the engine and engage the machine parking brake.

 **WARNING: Always stop the machine on a level surface, stop the engine and engage**

the parking brake before working on the machine to keep it from rolling.

2. Jack up the rear of the machine at the designated locations.

 **WARNING: Jack up the machine only at the designated locations to keep it from tipping.**

3. Block up the machine with jack stands.
4. Loosen the rod end nut connecting the directional control pedal to the control linkage.
5. Position the middle of the directional control pedal 34° off the floor plate.
6. Tighten the rod end nut connecting the directional control pedal to the control linkage.
7. Start the engine.
8. Loosen the pump centering springs mounting bracket bolts. Center the pump arm around the plate springs. Tighten the bolts.
9. Move the directional control pedal into the “forward” position and release it. The rear wheel should stop rotating as soon as the pedal is released. Adjust the spring mounting bracket position to the rear wheel stops when the pedal is released.
10. Move the directional control pedal into the “reverse” position and release it. The rear wheel should stop rotating as soon as the pedal is released. Adjust the spring mounting bracket position so the rear wheel stops when the pedal is released. Recheck the “forward” position adjustment as in step 9.
11. Stop the engine.
12. Raise the rear of the machine, remove the jack stands, and lower the machine.
13. Adjust the extended shock absorber rod ball joints so the machine does not travel above 6 mph (9.7 km/h) in reverse.

SPEED LIMITER

The machine speed limiter limits the maximum speed the machine can travel when the hopper is raised. The speed limiter should be adjusted whenever the pump control linkage is adjusted. The machine should not travel more than 2 mph (3.2 km/h) with the hopper raised.

The speed limiter is adjusted by tightening or loosening the speed limiter cable. One threaded end of the cable is located on the right lift arm. The other end of the cable, which is also threaded, is located on a flat sided sheave next to the directional control pedal. Tighten the cable to reduce the machine speed when the hopper is raised. Loosen the cable to increase the machine speed when the hopper is raised.

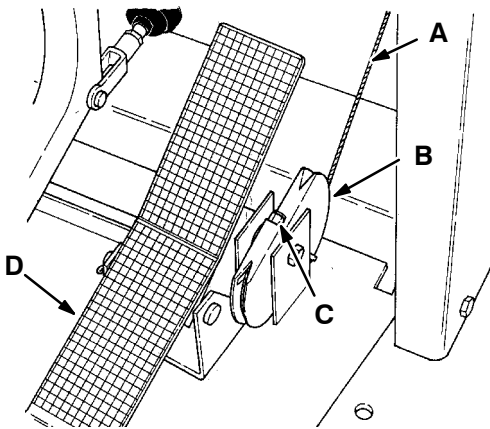

SPEED LIMITER CABLE

- A. Speed Limiter Cable
- B. Flat Sided Sheave
- C. Cable Adjusting Nut
- D. Directional Pedal

HYDRAULIC FLUID LEAKS

Fluid escaping from a very small hole can be almost invisible. Use a piece of cardboard or wood, rather than hands, to search for suspected leaks.

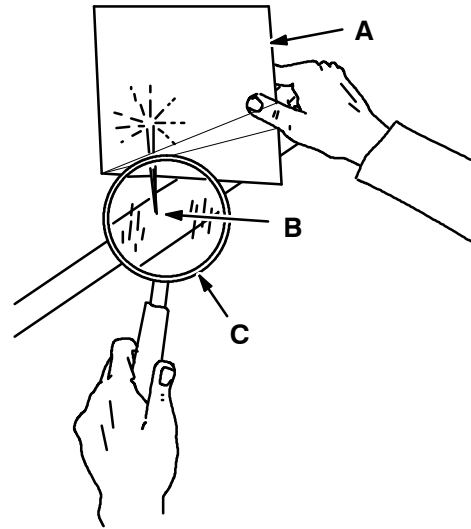

HYDRAULIC PINHOLE LEAK

- A. Cardboard
- B. Pinhole Leak
- C. Magnifying Glass

00002

If injured by escaping fluid, see a doctor at once. Serious infection or reaction can develop if proper medical treatment is not administered immediately.

! WARNING: Escaping hydraulic fluid under pressure can have sufficient force to penetrate the skin, causing serious personal injury. Before applying pressure to the system, be sure all connections are tight and that lines, pipes, and hoses are not damaged.

01463

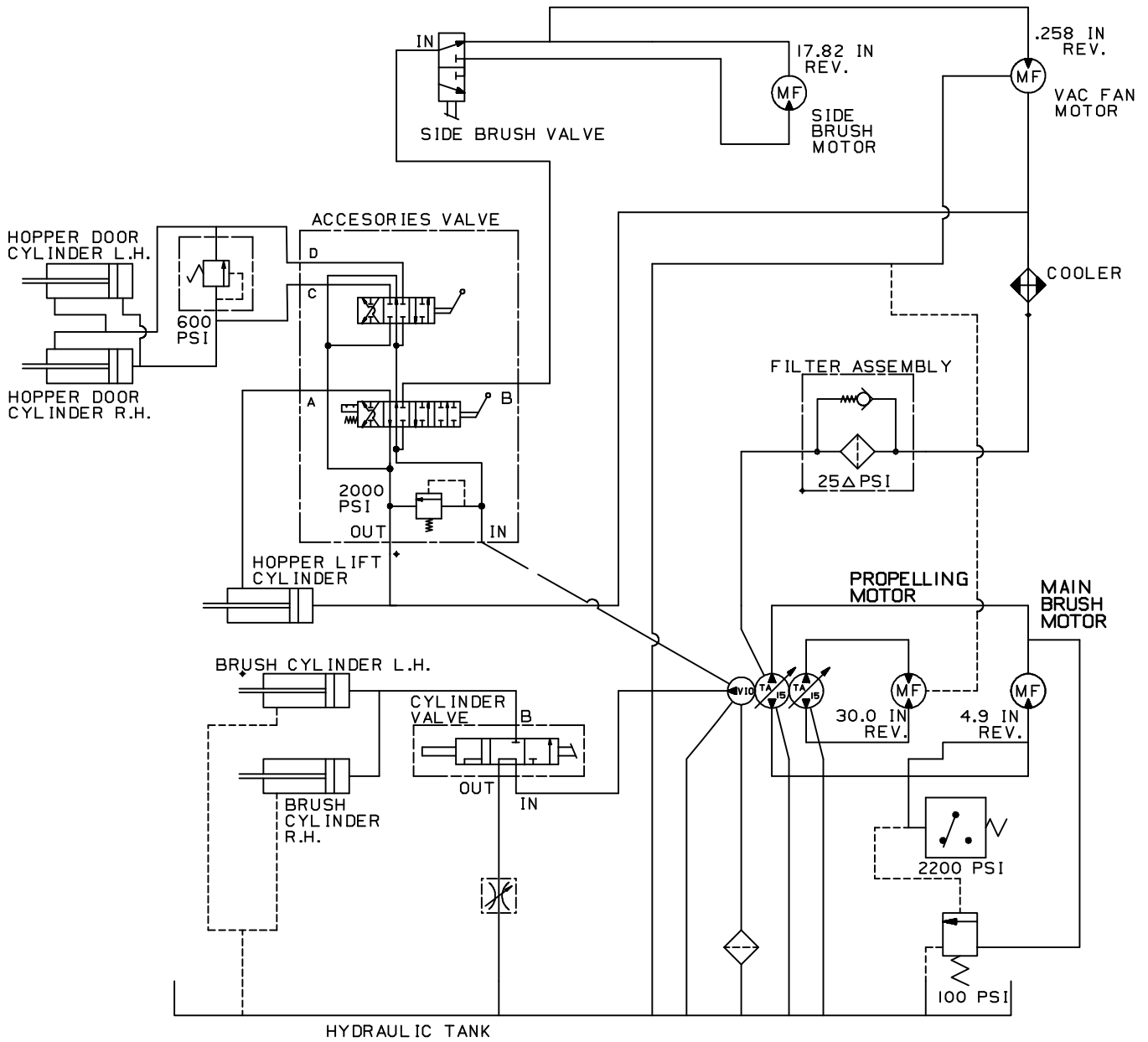

HYDRAULIC SCHEMATIC

04307

HYDRAULIC SYSTEM TROUBLESHOOTING

Problem	Cause	Remedy
Machine travels slowly or not at all	Parking brake engaged	Release parking brake
	Control linkage broken or not adjusted properly	Replace and/or adjust linkage
	Relief valve stuck open (leaking)	Clean or replace relief valve – one forward, one reverse
	Motor failure	See Hydraulic Components Troubleshooting
	Pump failure	See Hydraulic Components Troubleshooting
	Hydraulic fluid level low	Fill hydraulic fluid reservoir
Main brush turns slowly or not at all	Hydraulic control valve failure	See Hydraulic Components Troubleshooting
	Hydraulic motor failure	See Hydraulic Components Troubleshooting
	Gear pump failure	See Hydraulic Components Troubleshooting
Side brush turns slowly or not at all	Hydraulic control valve failure	See Hydraulic Components Troubleshooting
	Hydraulic motor failure	See Hydraulic Components Troubleshooting
	Relief valve in control valve sticking	Clean or replace relief valve
	Gear pump failure	See Hydraulic Components Troubleshooting
Poor or no vacuum to brush compartment	Hydraulic control valve failure	See Hydraulic Components Troubleshooting
	Hydraulic motor failure	See Hydraulic Components Troubleshooting
	Gear pump failure	See Hydraulic Components Troubleshooting
Hopper will not lift	Hydraulic control valve failure	See Hydraulic Components Troubleshooting
	Hydraulic orifice at lift cylinder plugged	Replace orifice
	Lift cylinder failure	See Hydraulic Components Troubleshooting
	Gear pump failure	See Hydraulic Components Troubleshooting
	Hopper overloaded	Empty hopper
	Lift arms binding	Replace and/or adjust lift arm linkage

Problem	Cause	Remedy
Hopper will not lower	Hydraulic control valve failure	See Hydraulic Components Troubleshooting
	Lift cylinder failure	See Hydraulic Components Troubleshooting
	Gear pump failure	See Hydraulic Components Troubleshooting
	Lift arms binding	Replace and/or adjust lift arm linkage
Hopper door will not roll out	Hydraulic control valve failure	See Hydraulic Components Troubleshooting
	Lift cylinder failure	See Hydraulic Components Troubleshooting
	Gear pump failure	See Hydraulic Components Troubleshooting
	Lift arms binding	Replace and/or adjust lift arm linkage

HYDRAULIC COMPONENTS TROUBLESHOOTING

Problem	Cause	Remedy
Hydraulic cylinder failure	Piston seals leaking	Install seal kit
	Barrel worn or rod bent	Replace cylinder
Hydraulic control valve failure	Valve seals leaking	Install seal kit
	Relief valve stuck open (leaking)	Clean or replace relief valve
Hydraulic motor failure	Motor leaking	Install seal kit
	Drive link failure	Replace drive link
	Gerotor worn	Replace gerotor set
	Output shaft failure	Replace output shaft and bearings
Hydraulic gear pump pump failure	Pump leaking	Install seal kit
	Gear set failure	Replace gear set
	Shaft failure	Replace gear set
	Flow divider failure	Replace back plate assembly
	Engine-to-pump coupling failure	Replace coupling
Hydraulic piston pump failure	Pump leaking	Install seal kit
	Relief valve stuck	Clean or replace relief valve
	Integral charge pump failure	Replace charge pump
	Rotating group worn	Replace rotating group
	Shaft failure	Replace shaft
	Backplate worn	Replace backplate
	Engine-to-pump coupling failure	Replace coupling

ENGINE

ENGINE LUBRICATION

Check the engine oil level daily. Change the engine oil and oil filter after every 50 hours of operation.

Change the engine oil more frequently if the environment is extremely dusty. Use only CD or CE rated engine oil.

The following SAE oil grades are general recommendations for engines during the changing seasonal temperatures.

BELOW 0°F (BELOW -17°C)	0+ to 32°F (-17+ to 0°C)	32+ to 75°F (0+ to 24°C)	ABOVE 75°F (ABOVE 24°C)
SAE 5W	SAE 10W	SAE20W	SAE 30
SAE 5W-20	SAE 10W-30	SAE 10W-30	SAE 10W-30
SAE 5W-30	SAE 10W-40	SAE 10W-40	SAE 10W-40

Multi-grade oil should cover the single grade recommendation for the temperatures involved. The engine oil capacity is 7 qt (6.6 L) with filter.

COOLING SYSTEM

Maintaining cooling system efficiency is important. Engine temperatures must be brought up to and maintained within the satisfactory range for efficient operation. However, the engine must be kept from overheating in order to prevent damage to the valves, pistons, and bearings.

Use soft, clean water mixed with permanent-type, ethylene glycol antifreeze in a one-to-one ratio. Deposits of sludge, scale, and rust prevent normal heat transfer. Flush the radiator and the cooling system after every 800 hours of operation using a dependable cleaning compound. Follow the mixing procedure recommended by the compound manufacturer. This is important because of the difference in concentration and composition of the cleaning compounds. After cleaning, flush the system with clean water.

Whenever a cooling system is badly rust-clogged as indicated by overflow loss or abnormally high operating temperatures, corrective cleaning by reverse flow flushing will most effectively remove the heavy deposits of sludge, rust, and scale. The reverse flow flushing should be performed immediately after draining the cleaning solution. Flush the radiator first, then the engine, to allow the engine to cool as much as possible.

Engine overheating may also be caused by dirty radiator fins. The exterior fins of the radiator can be cleaned with an air hose. Check them for clogging after every 100 hours of operation. Blow out all dust,

dirt, etc., between the fins, if necessary. This should be done only after the radiator has cooled off to avoid cracking caused by uneven cooling.

Before cleaning, remove the fan shroud from the radiator, then blow out all dust from outside the machine into the engine compartment (this is the opposite direction from normal air flow). After the radiator fins are clean, replace the fan shroud.

The engine is equipped with a 180°F (82°C) thermostat. Normal engine temperature is 200°F (93°C). Temperatures up to 220°F (104°C) are allowable. Temperatures over 200°F (93°C) indicate a problem exists.

A pressure cap is used on the radiator to prevent overflow loss of water during normal operation. The spring-loaded valve in the cap closes the outlet to the overflow pipe of the radiator and thus seals the system. Pressure developing within the system raises the boiling point of the coolant and allows higher temperatures without overflow loss from boiling. The pressure valve opens at 15 psi (100 kPa), allowing steam and water to pass out the overflow pipe.

 **WARNING: If the coolant is hot or if the engine has been operating, let the engine cool. Hot coolant could scald or cause severe burns. If in doubt, let the coolant cool before releasing pressure in the cooling system.**

ATTENTION! Never pour cold water or cold antifreeze into the radiator of an overheated engine. Allow the engine to cool and avoid the danger of cracking the cylinder head or block. Keep the engine running while adding water.

AIR INTAKE SYSTEM

The importance of maintaining an air filter in proper condition cannot be overemphasized. Dirt induced through improperly installed, improperly serviced, or inadequate air filter elements wears out more engines than long hours of operation. Even a small amount of dirt will wear out a set of piston rings in just a few hours. Operating with a clogged air filter element also causes the fuel mixture to be leaner, which can lead to formation of harmful sludge deposits in the engine. Always cover the air intake when the air filter is removed for servicing. Do not neglect servicing the air filter. Use only approved replacement parts. Keep all other air intake

components secure and in good condition to prevent entrance of unfiltered air.

Overmaintenance can cause more damage than good. Removing the air filter element more often than is needed allows contaminants to enter the engine unnecessarily. Clean or replace the air filter element only when the restriction indicator indicates excessive restriction in the system.

AIR FILTER RESTRICTION INDICATOR

The air filter restriction indicator signals when to change the air filter element. Check the restriction indicator daily. The red indicator gradually becomes visible as the air filter element loads with dirt. Replace the filter element when the red indicator of the air filter restriction indicator locks in the visible position.

When the red indicator is locked in the visible position, the indicator may return to the non-visible position when the engine is shut off. It will return to the visible position when the engine is started. After replacing the air filter element, reset the service indicator by pushing the "reset" end of the indicator.

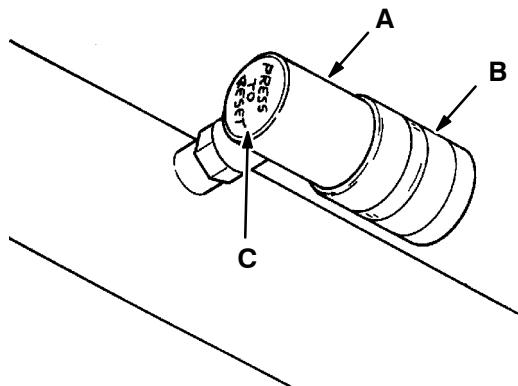

AIR CLEANER SERVICE INDICATOR

- A. Service Indicator
- B. Red Indicator Window
- C. Indicator Reset

AIR FILTER

The engine air filter element is a dry cartridge-type filter. The air filter element replaced whenever the red indicator of the air filter restriction indicator locks in the visible position.

Service the air filter element only when the restriction indicator indicates excessive restriction in the system. Do not remove air filter element unless it is restricting air flow.

TO REPLACE AIR FILTER ELEMENT

1. Stop the engine and engage the machine parking brake.

⚠ WARNING: Always stop the machine on a level surface, stop the engine and engage the parking brake before working on the machine to keep it from rolling.

2. Loosen the air filter clamp nuts.

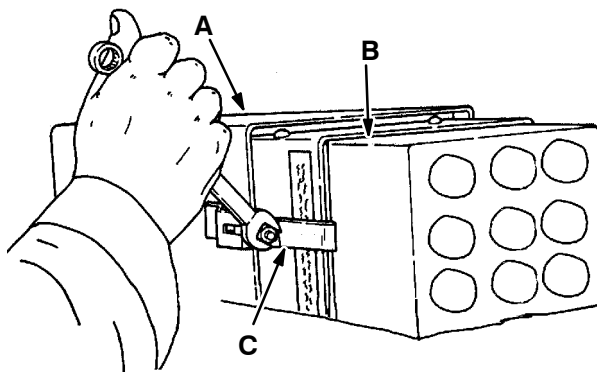

DISASSEMBLING AIR FILTER

- A. Air Filter Housing
- B. Pre-Cleaner
- C. Air Filter Clamp

3. Remove the two air filter clamps and swing the pre-cleaner cover out of the way.
4. Remove the pre-cleaner.
5. Slide the air filter element out of the filter housing. Discard it—do not attempt to clean the filter element.

01468

00212

- Slide a new filter element into the filter housing, rounded end first.

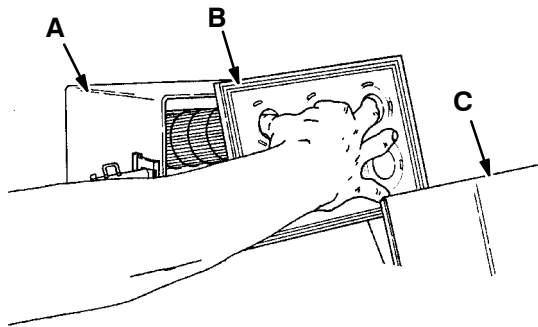

INSTALLING AIR FILTER ELEMENT

01469

- A. Filter Housing**
- B. Air Filter Element**
- C. Pre-Cleaner**

- Position the pre-cleaner on the filter housing.
- Position the pre-cleaner cover on the pre-cleaner with the air filter clamps.
- Tighten the air filter clamp nuts to 75 in lb (8 Nm).

FUEL SYSTEM – DIESEL

DIESEL FUEL SYSTEM

The diesel fuel system is made up of five basic components which are: fuel tank, fuel water trap-filter, fuel pump, injection pump, and injectors.

Fuel flows from the fuel tank through the fuel water trap-filter. The water trap-filter separates water and impurities from the fuel. From the fuel water trap-filter, fuel is drawn through the electric fuel pump and pumped to the injection pump. The injection pump pressurizes and sends fuel to the injectors. The injectors atomize and inject proper amounts of fuel into the combustion chamber at the proper times. Excess fuel is returned to the fuel tank through an overflow pipe.

FUEL WATER TRAP

The fuel water trap separates water from the fuel. It is located in front of the radiator.

Drain the water trap of water daily. To drain the water trap, loosen the drain knob on the bottom of the unit. First water, then diesel fuel will drain. Tighten the

drain knob when diesel fuel appears.

After every 100 hours of operation, the water trap must be cleaned as described in To Clean Water Trap.

TO CLEAN WATER TRAP

- Stop the engine and engage the machine parking brake.

! WARNING: Always park and level surface, stop the engine, and engage parking brake before working on the machine to keep it from creeping or rolling.

- Thoroughly clean the exterior of the water trap.
- Unscrew the bowl retaining bolt in the center of the water trap head.

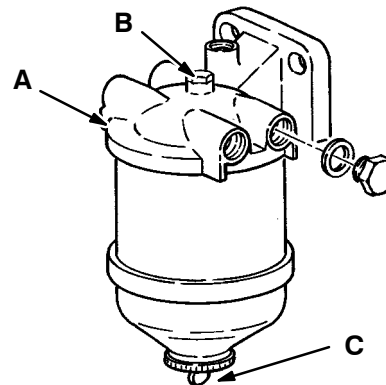

WATER TRAP

00210

- A. Water Trap**
- B. Bowl Retaining Bolt**
- C. Drain Spigot**

- Lower the bowl from the water trap head.
- Thoroughly clean the water trap bowl in cleaning fluid.

NOTE: Do not use gasoline to clean the bowl.

- After cleaning the water trap bowl, fill the bowl with clean fuel. Hold the water trap bowl in position under the water trap head.
- Secure the bowl retaining bolt.
- Prime the fuel system as described in Priming the Fuel System.

FUEL FILTER

The fuel filter is mounted on the top right side of the engine. The fuel filter should be replaced after every 400 hours of operation.

TO REPLACE THE FUEL FILTER

1. Thoroughly clean the exterior of the fuel filter assembly.
2. Unscrew the filter bolt in the center of the head.

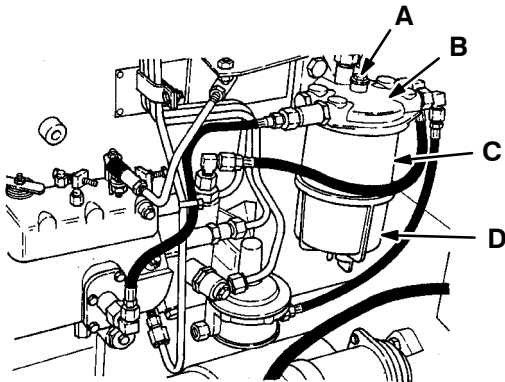

FUEL FILTER

01475

- A. Filter Bolt
- B. Filter Head
- C. Filter Element
- D. Filter Bowl

3. Lower the filter bowl and element and discard the fuel, together with the old element.
4. Thoroughly clean the filter bowl in cleaning fluid.

NOTE: Do not use gasoline as a cleaning fluid.

5. Place the new element and sealing rings in position, fill with clean fuel, and push the bowl up firmly and squarely so that the top rim of the filter element locates centrally against the sealing ring in the filter head.
6. Hold in this position while the securing bolt is located and tightened. If the bowl is located correctly, no excessive tightening will be required to obtain a leak-proof seal.

After the fuel filter has been reassembled, it is necessary to remove air from the fuel system. See Bleeding Fuel System.

FUEL INJECTION PUMP

The fuel injection pump controls the engine speed.

The maximum speed screw is set and sealed by the manufacturer and must not be altered in any way unless factory authority is first obtained. Any adjustments should be carried out by experienced fuel pump technicians. The unauthorized removal of any seals on the pump may void the warranty.

ATTENTION! Unless proper test equipment and trained technicians are available, adjustment or maintenance of the fuel injection pump should not be attempted.

FUEL INJECTORS

When replacing injectors in the cylinder head, it is essential that a new, correct-type heat shield washer be fitted between the nozzle cap and the cylinder head.

Care should be used when replacing the fuel injectors to prevent loosening the injector leak-off nipples.

Be sure to cut a relief in the inside of your socket for clearance. This will prevent an interference between the socket and the leak-off nipple.

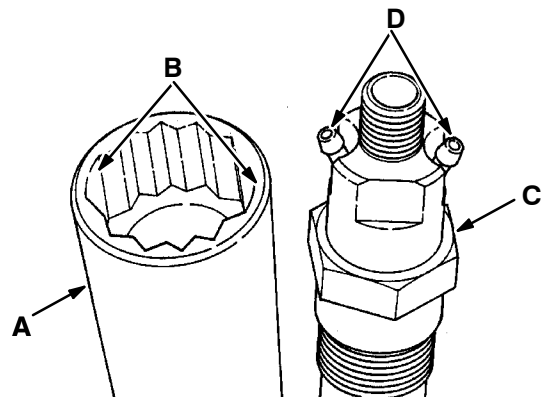

SOCKET RELIEF CLEARANCE

01477

- A. Socket
- B. Relief
- C. Injector
- D. Leak-Off Nipple

Tighten injectors evenly to 52 ft lb (70 Nm).

Injectors should be taken out only if engine is malfunctioning as outlined below:

- A. Misfiring
- B. Knocking in one (or more) cylinders
- C. Engine overheating
- D. Loss of power
- E. Smoky exhaust (black or white)
- F. Increased fuel consumption

The faulty injector or injectors may be located by loosening the line fitting nut on each, in turn, with the engine running at a fast idle. This allows the fuel to escape and not enter the cylinder. The injector least affecting the engine performance should be removed from the cylinder head and reconditioned or replaced.

CAUTION: Keep hands and face from coming into contact with atomizer spray, as the working pressure will cause fuel oil to penetrate the skin.

NOTE: No attempt should be made to adjust the injection pressure without a proper testing pump and pressure gauge. It is impossible to adjust the setting of the injector with any degree of accuracy without proper equipment.

⚠ WARNING: Do not start the engine with loose injector securing nuts; this may result in the injector flying out.

PRIMING THE FUEL SYSTEM

Priming is necessary on initial installation of the fuel injection system, after any subsequent removal, or if the system was drained by running out of fuel.

Before priming and venting, ensure that the outside of the vent screws and surrounding area is thoroughly clean to prevent dirt and foreign matter entering the system.

NOTE: Electrical equipment such as starters should be shielded during priming to prevent fuel entry.

Carry out steps 1 and 2 while operating the fuel lift pump priming lever.

1. Operate the fuel lift pump priming lever and loosen the filter outlet connection until fuel

flows free of air.

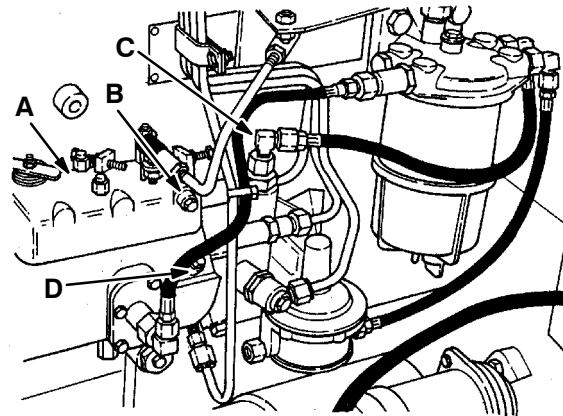

INJECTION PUMP VENTS

- A. Injection Pump
- B. Top Vent Valve
- C. Fuel Pump Inlet
- D. Governor Housing Vent Connection

01475

2. Continue operating the fuel lift pump priming lever while loosening the top vent valve and the vent screw on the governor housing. When fuel flows free of air, tighten the connections. Stop operating the priming lever and place it in the vertical position.

NOTE: Leaving the priming lever in the horizontal position will lock the pump action stopping the fuel supply.

3. Loosen any two injector high pressure pipe nuts at the injector end. Set the accelerator to the fully "open" position and ensure that the stop control is in the "run" position. Crank engine until fuel is free of air bubbles. Tighten nuts.

NOTE: The bleeding operation may take a considerable amount of cranking with the starter to purge all air. It is important that the battery be in good operating condition when bleeding.

If the engine will not start after bleeding, or any other time, it may be an indication of a low battery charge. If the voltage to the fuel shutoff solenoid falls below 8 volts, the valve will shut off fuel to the engine. This may happen during cranking if the battery charge is low. The condition may not be readily apparent since cranking speed might still be good.

4. Start the engine.

DIESEL FUEL TROUBLESHOOTING

Problem	Cause	Remedy	
Engine will not start	Out of fuel	Fill fuel tank	
	Filter plugged	Clean filter	
	Air in fuel	Bleed fuel lines	
	Water in fuel	Drain water trap	
	Fuel too thick	Change fuel grade	
	Battery discharged	Charge or replace battery	
	Clogged fuel nozzle	Clean or replace nozzle	
	Valve clearance wrong	Adjust valves	
	Leaking valves	Grind valves	
	Timing wrong	Adjust timing	
	Low compression	Repair engine	
Engine runs unevenly or lacks power	Dirty air filter	Clean or replace filter	
	Plugged fuel filter	Clean filter	
	Water in fuel	Drain water trap	
	Fuel too thick	Change fuel grade	
	Clogged fuel nozzle	Clean or replace nozzle	
	Low compression	Repair engine	
	Engine overheating		Check radiator
			Check lubricating system
	Timing wrong	Check timing	
	Valve clearance wrong	Adjust valves	
	Fuel pressure wrong	Adjust pressure	
Injection pump worn	Repair or replace pump		
Engine stops suddenly	Fuel leak	Check fuel system	
	Out of fuel	Fill fuel tank	
	Fuel nozzle bad	Replace nozzle	
	Engine overheating		Check radiator
			Check lubricating system
	Timing wrong	Check timing	
Exhaust color bad	Fuel governor failure	Repair or replace	
	Bad fuel	Change fuel grade	
	Fuel nozzle bad	Replace nozzle	
	Timing wrong	Check timing	
	Low compression	Repair engine	
	Valve clearance wrong	Adjust valves	
	Injection pump worn	Repair or replace pump	

CYLINDER HEAD

CYLINDER HEAD

The proper sequence and torque values should be used when reassembling the cylinder head. The cylinder head bolts must be tightened in the proper sequence after the first 50 hours of operation.

Hand torque cold M10 bolts to 50 to 55 ft lb (68 to 75 Nm) and M12 bolts to 80 to 85 ft lb (108 to 115 Nm) in the correct order.

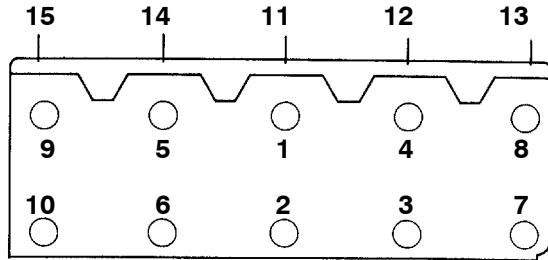

01472

CYLINDER HEAD BOLT TIGHTENING SEQUENCE

The cylinder head cap screws and risers must be re-torqued after the engine is put into operation and brought up to proper operating temperatures. To re-torque cap screws, follow the correct sequence. Loosen one head cap screw or riser at a time one quarter turn (90 degrees); then re-torque it to the correct value. Check the valve tappet clearance.

NOTE: Power wrench torque limit must be held at least 10 ft lb (14 Nm) below hand torque specification; then hand torque to the specifications.

VALVE TAPPET CLEARANCE ADJUSTMENT

The valve tappet clearance must be checked after the first 50 hours of operation and after every 400 hours of operation.

Check and adjust the intake valve tappets to 0.014 in (0.36 mm) clearance and the exhaust valve tappets to 0.018 in (0.46 mm) clearance when the engine is warm and is operating at idle speed.

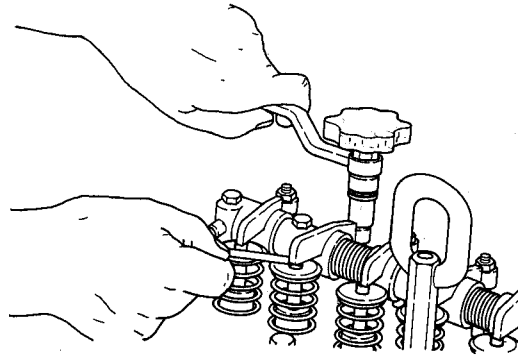

01473

ADJUSTING VALVE TAPPET CLEARANCE

ELECTRICAL SYSTEM

BATTERY

The battery is rated at 12 V, 625 ccA. It is located next to the engine and hydraulic pump.

Do not allow the battery to remain in discharged condition for any length of time.

Do not operate the machine if the battery is in poor condition or discharged beyond 80%, specific gravity below 1.130.

Clean the top surface and the terminals of the battery periodically. Use a strong solution of baking soda and water. Brush the solution sparingly over the battery top, terminals, and cable clamps. Do not allow any baking soda solution to enter the battery. Use a wire brush to clean the terminal posts and the cable connectors. After cleaning, apply a coating of clear petroleum jelly to the terminals and the cable connectors. Keep the top of the battery clean and dry.

Keep all metallic objects off the top of the battery, as they may cause a short circuit. Replace worn or damaged wires.

The electrolyte level must always be above the battery plates. Add distilled water to maintain solution at the correct level above the plates, but do not overfill. Never add acid to batteries, only water. Keep vent plugs firmly in place at all times, except when adding water or taking hydrometer readings.

 **WARNING: Avoid contact with battery acid. Battery acid can cause severe burns. Wash immediately and get medical attention if contact with battery acid occurs.**

If when checking battery specific gravity, one or more battery cells tests lower than the other battery cells, (0.050 or more) the cell is damaged, shorted, or is about to fail.

NOTE: Do not take readings immediately after adding water – if the water and acid are not thoroughly mixed, the readings may not be accurate. Check the hydrometer readings against this chart:

SPECIFIC GRAVITY at 80° F (27° C)	BATTERY CONDITION
1.260 – 1.280	100% charged
1.230 – 1.250	75% charged
1.200 – 1.220	50% charged
1.170 – 1.190	25% charged
1.110 – 1.130	Discharged

NOTE: If the readings are taken when the battery electrolyte is any temperature other than 80° F (27° C), the reading must be temperature corrected.

To determine the corrected specific gravity reading when the temperature of the battery electrolyte is other than 80° F (27° C):

Add to the specific gravity reading 0.004, 4 points, for each 10° F (6° C) above 80° F (27° C).

Subtract from the specific gravity reading 0.004, 4 points for each 10° F (6° C) below 80° F (27° C).

When removing battery cables, remove the negative (–) cable before the positive (+) cable.

 **CAUTION: Always remove the negative (–) battery cable before the positive (+) battery cable to prevent accidental electrical shorting and personal injury.**

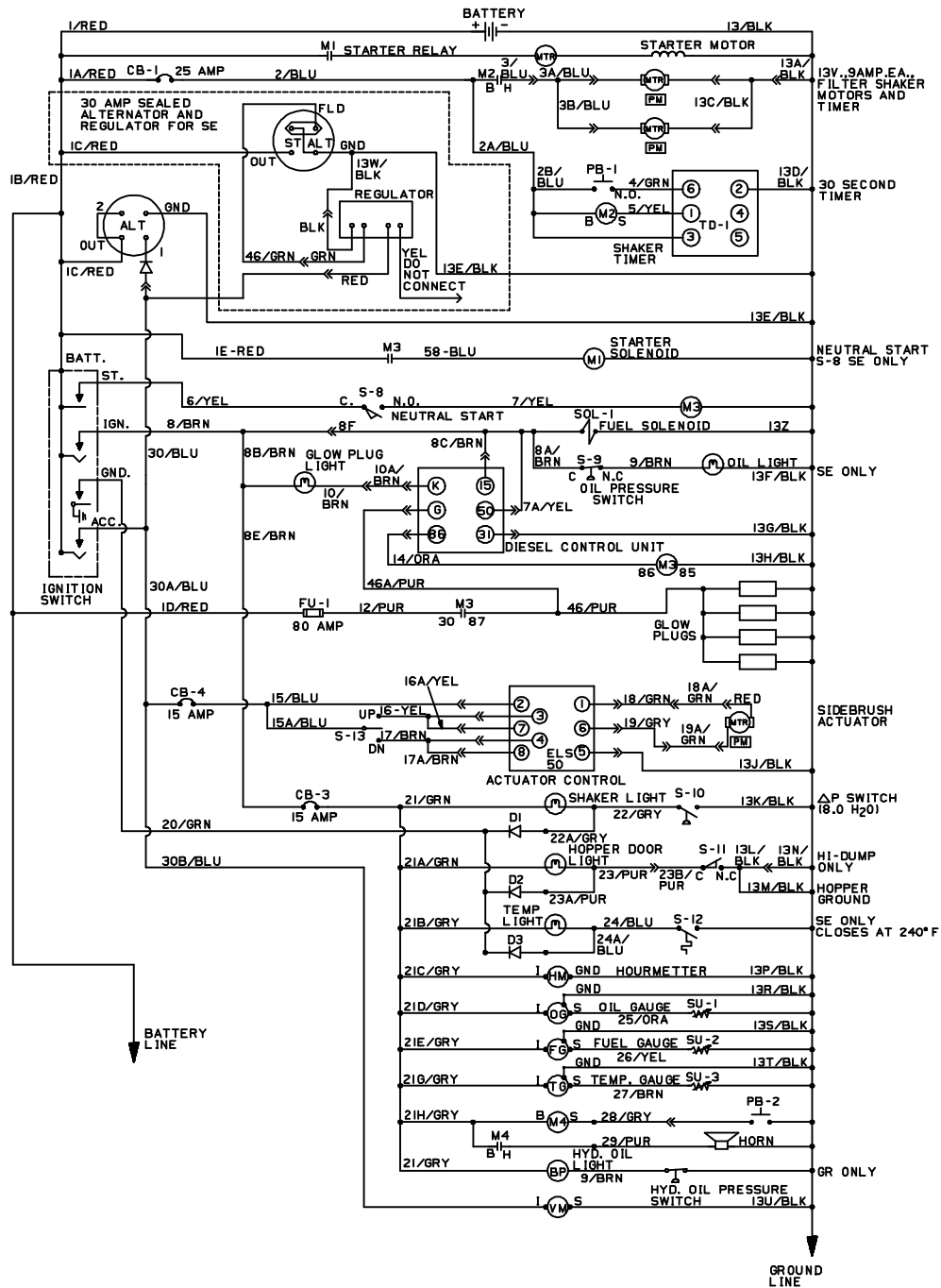

LEGEND			
M	POWER RELAY	HM	HOURLMETER
MTR	MOTOR	SV	SOLENOID VALVE
CB	CIRCUIT BREAKER	S	SWITCH
PM	PERMANENT MAGNET	ACC	ACCESSORY
J	JACK-FEM. SOCKET	GND	GROUND CHASSIS
P	PLUG-MALE PIN	C	COMMON
PB	PUSHBUTTON	N.O.	NORMALLY OPEN
VM	VOLTMETER	N.C.	NORMALLY CLOSED
FU	FUSE		

ELECTRICAL SCHEMATIC

04309

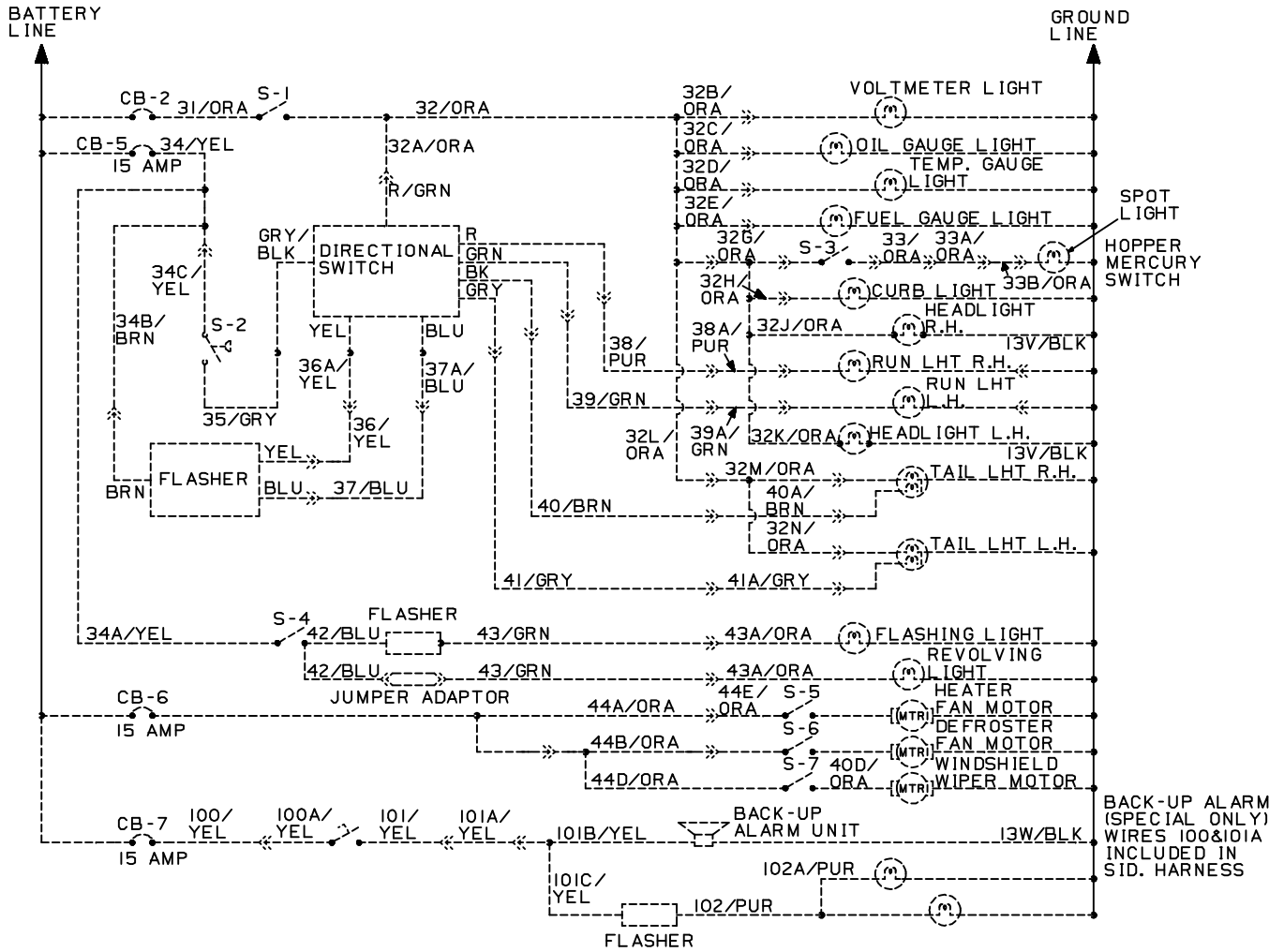

LEGEND			
M	POWER RELAY	HM	HOURLMETER
MTR	MOTOR	SV	SOLENOID VALVE
CB	CIRCUIT BREAKER	S	SWITCH
PM	PERMANENT MAGNET	ACC	ACCESSORY
J	JACK-FEM. SOCKET	GND	GROUND CHASSIS
P	PLUG-MALE PIN	C	COMMON
PB	PUSHBUTTON	N.O.	NORMALLY OPEN
VM	VOLTMETER	N.C.	NORMALLY CLOSED
FU	FUSE		

ELECTRICAL SCHEMATIC, ACCESSORIES

01502

BELTS AND CHAINS

ENGINE FAN BELT

To tighten the fan belt, loosen the alternator adjusting bolts and pull out on the alternator by hand until the belt is just snug. Do not use a pry bar on the alternator to tension the fan belt, as damage to the bearings will result. Then tighten the alternator adjusting bolts.

Check the fan belt tension after every 50 hours of operation.

Proper belt deflection is obtained when the belt deflects 0.5 in (13 mm) from a force of 10 to 12 lb (4.5 to 5.4 kg) applied at the midpoint of the longest span.

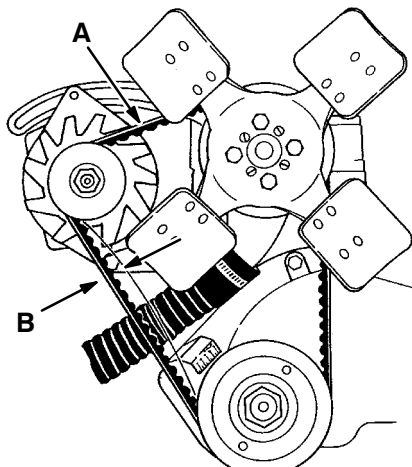

ENGINE FAN BELT

- A. Fan Belt
- B. 0.5 in (13 mm)

STATIC DRAG CHAIN

A static drag chain is provided to prevent the buildup of static electricity in the machine. The chain is attached to the machine by a rear brush skirt retaining bolt.

Check the chain for wear. Make sure that it is making contact with the floor at all times.

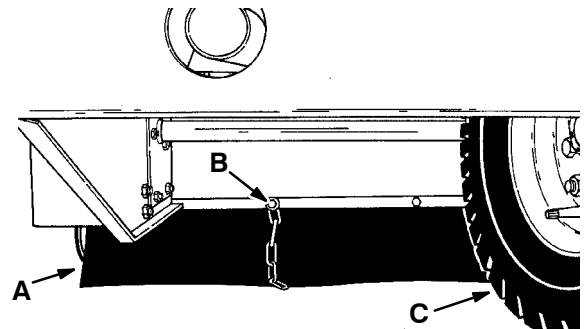

STATIC DRAG CHAIN

- A. Rear Dust Skirt
- B. Static Drag Chain
- C. Rear Tire

01479

00577

DEBRIS HOPPER

HOPPER DUST FILTERS

There are two dust filter cartridges located inside of the hopper. The dust filters filter the air which is drawn up from the main brush compartment through the hopper. The dust filters are equipped with shaker motors to remove the accumulated loose dust particles. The dust filter shaker motors are operated by a pushbutton switch located on the instrument panel. Shake the dust filters before dumping the hopper and at the end of every work shift. Inspect and clean or replace the dust filters after every 100 hours of operation.

To clean the dust filters use one of the following methods:

TAPPING – Tap the filter gently on a flat surface with the dirty side down. Do not damage the edges of the filter element or the filter will not seat properly in the filter frame.

AIR – Blow compressed air, 100 psi (690 kPa) maximum, through the dust filter opposite the direction of the arrows. This may be done with the dust filters in the machine.

WATER – Soak the dust filter in a water and mild detergent solution. Rinse the dust filter until it is clean. The maximum water pressure allowable is 40 psi (275 kPa). Air dry the wet dust filter; do not use compressed air.

NOTE: Be sure the dust filters are dry before reinstalling them in the machine.

TO REMOVE HOPPER DUST FILTERS

1. Stop the engine and engage the machine parking brake.

! WARNING: Always stop the machine on a level surface, stop the engine and engage the parking brake before working on the machine to keep it from rolling.

2. Push the hopper cover latch release button and lift the hopper cover.
3. Dislodge the hopper cover prop arm from its storage and position it in the hopper cover prop arm receptacle.
4. Lower the hopper cover onto the prop arm.

5. Disconnect the shaker motor wire connectors.
6. Remove the two dust filter spring mounting bolts from each spring set with a 0.25 in allen wrench.

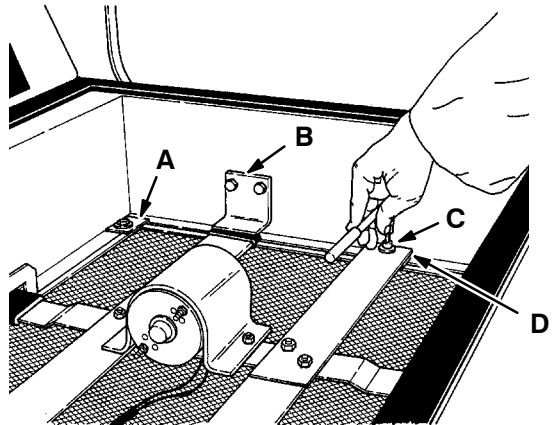

01480

REMOVING SPRING MOUNTING BOLTS

- A. Retaining Tab
- B. L Bracket
- C. Spring Bolt
- D. Shaker Shim

7. Remove the two dust filter retaining tabs on each dust filter.
8. Remove the two side L brackets.

- Lift the dust filter shaker assembly off each of the dust filter elements.

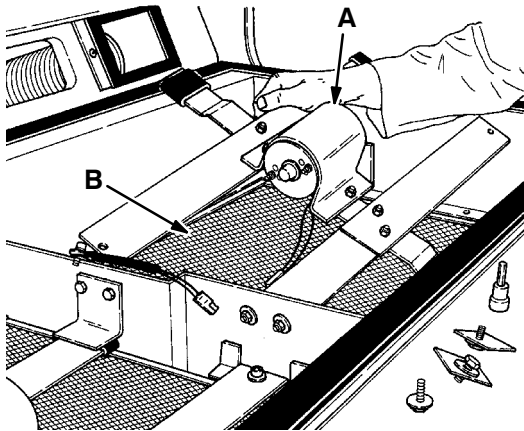

01481

REMOVING DUST FILTER SHAKER ASSEMBLY

- A. Dust Filter Shaker Assembly
- B. Dust Filter Element

- Lift the shaker shims off the filters and filter frames.
- Lift the dust filter elements out of the dust filter frames.
- Clean or discard the dust filters as required.

TO INSTALL HOPPER DUST FILTERS

- Place the cleaned or new dust filters in the hopper dust filter frames with the arrows pointing up.

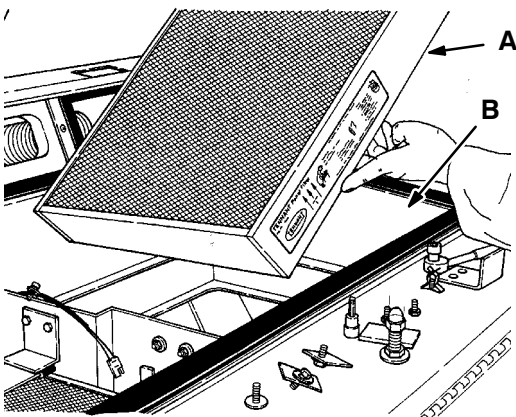

01482

INSTALLING DUST FILTER

- A. Dust Filter
- B. Dust Filter Frame

- Place the four shaker shims in position.
- Slide the dust filter shaking assemblies in position over the dust filters.
- Thread the two allen head socket bolts through the mounting springs and into the dust filter frames of each filter. Tighten the bolts.
- Replace the two side L brackets and four filter retaining tabs.
- Reconnect the shaker motor wire connectors.
- Push the hopper cover open, lower and store the prop arm under its retaining clip, and close the hopper cover.

HOPPER FUSIBLE LINK

The hopper fusible link is a device which, in case of a fire in the hopper, allows the hopper fire door to close, cutting off air to the fire.

The fusible link is positioned between the hopper fire door and the hopper frame. It is accessible through the hopper inspection door.

If a loss of dust control is noticed, check the fusible link for breakage or failure due to heat.

TO REPLACE HOPPER FUSIBLE LINK

- Stop the engine and engage the machine parking brake.

WARNING: Always stop the machine on a level surface, stop the engine and engage the parking brake before working on the machine to keep it from rolling.

- Open the hopper inspection door.
- Remove the existing pieces of fusible link and their retaining clips.

- Slide a new fusible link over the link mounting pins.

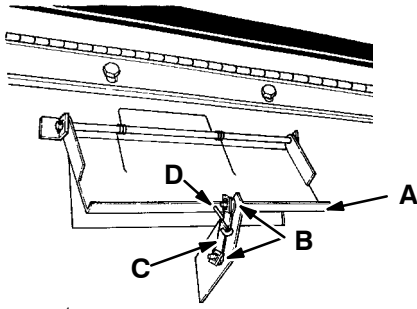

FUSIBLE LINK INSTALLATION

- A. Fire Door
- B. Retaining Clip
- C. Fusible Link
- D. Fire Door Hook

- Push the link retaining clips onto the mounting pins.
- Open the fire door.
- Place the fire door hook over the middle of the fusible link.
- Close the hopper inspection door.

DEBRIS HOPPER

The debris hopper collects debris swept up by the main brush. The hopper has one regularly scheduled adjustment – hopper floor clearance. Check it after every 50 hours of operation. Proper floor clearance must be maintained to prevent the hopper from trailing debris.

TO CHECK AND ADJUST HOPPER FLOOR CLEARANCE

- Place the hopper in the “operating” position, stop the engine, and engage the parking brake.

WARNING: Always stop the machine on a level surface, stop the engine, and engage the parking brake before working on the machine to keep it from rolling.

- Slide a 1.5 in (40 mm) thick block under each side of the rear of the hopper. This is the amount of floor clearance needed by the hopper. If the hopper needs adjustment, continue.
- Loosen the floor clearance bolt jam nut on each side of the hopper.

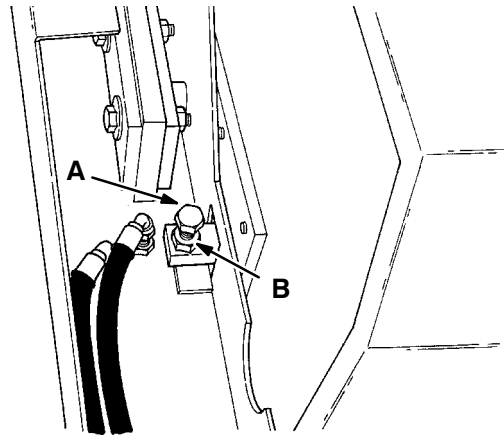

FLOOR CLEARANCE ADJUSTMENT BOLT

- A. Adjustment Bolt
- B. Jam Nut

- Thread the adjustment bolts in to increase the floor clearance or thread the adjustment bolts out to decrease floor clearance.
- Tighten the jam nuts.

STABILIZER LEG

The machine stabilizer leg is a safety device which, when the machine is being high dumped, projects downward to act as an anti-tipping device. Check the stabilizer leg daily to be sure it is down when the machine is being high dumped and is fully retracted when the hopper is in the “operating” position. Check for proper operation daily. Lubricate the leg pivot pin after every 200 hours of operation.

TO ADJUST STABILIZER LEG

1. Place the hopper in the “operating” position.
2. Make sure the front bumper is not resting on the stabilizer leg assembly. If it is, loosen the leg assembly mounting bolts, slide the leg assembly down, and retighten the bolts.
3. Loosen the activating arm pinch bolt.
4. Hold the stabilizer leg in the “fully raised” position.

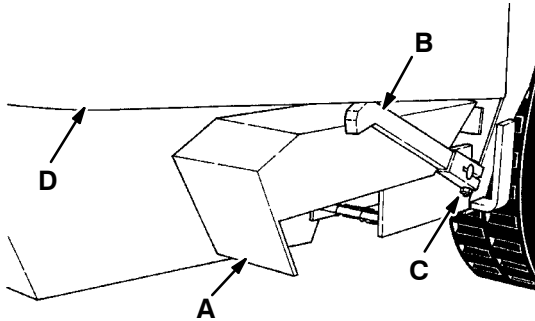

01440

STABILIZER LEG

- A. Stabilizer Leg**
- B. Arm**
- C. Pinch Bolt**
- D. Bumper**

5. Position the arm so it contacts the bottom of the front bumper and tighten the pinch bolt.
6. Start the engine and raise the hopper. Check to make sure the leg is in the “lowered” position.
7. Lower the hopper and check to make sure the leg is fully retracted into the “raised” position.

BRUSHES

MAIN BRUSH/WIRE BRUSH

The main brush/wire brush should be inspected daily for wear or damage. Remove any string or wire found tangled on the brush, brush drive hub, or brush idler hub.

Rotate the brush end–for–end after every 50 hours of operation for maximum brush life.

The main brush should be replaced when the remaining bristle measures 1.25 in (30 mm) or less in length. The wire brush should be replaced when the remaining bristle measures 1 in (25 mm) or less in length.

The main brush pattern should be checked daily. The main brush pattern should be 2 to 2.5 in (50 to 65 mm) wide with the main brush in the “restricted down” position. Main brush pattern adjustments are made by turning the height adjustment knob behind the side shroud next to the operator’s left leg.

TO REPLACE MAIN BRUSH OR WIRE BRUSH

1. Place the brush power lift lever in the “up” position.
2. Stop the engine and engage the machine parking brake.

 **WARNING: Always stop the machine on a level surface, stop the engine and engage the parking brake before working on the machine to keep it from rolling.**

3. Open the right brush access door.

NOTE: If replacing a wire brush, slide the wire brush dolly into position under the wire brush.

4. Place the main brush lever in the “free–float” position.

 **CAUTION: Wear gloves when replacing the main brush to protect your hands.**

5. Disconnect the clevis from the brush arm.
6. Remove the brush idler arm retaining bolt from the arm hub.

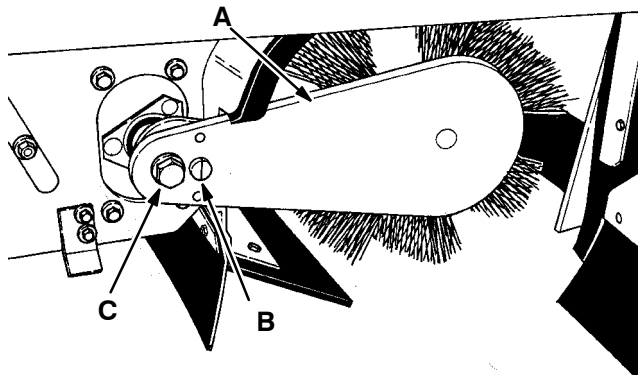

01486

MAIN BRUSH IDLER ARM

- A. Brush Idler Arm**
- B. Plastic Screw**
- C. Arm Retaining Bolt**

7. Pull the brush idler arm off the arm hub.

NOTE: If the brush idler arm does not come off easily, remove the plastic screw located next to the hole where the brush idler arm retaining bolt was mounted. Thread the brush idler arm retaining bolt into the threaded hole the plastic screw came out of. Tighten the retaining bolt until it forces the brush idler arm loose. Remove the brush idler arm retaining bolt and replace it with the plastic screw.

8. Pull the main brush off the brush drive plug and out of the main brush compartment.

NOTE: If the brush does not come off easily, remove the three plastic screws located on the brush drive arm and thread bolts into the holes to push the brush off the drive plug.

9. Clean the brush drive and idler plugs. Apply a coat of grease to them to make brush removal and installation easier.
10. Place the new or rotated main brush on the floor next to the access door.
11. Align the main brush drive slots with the drive keys on the main brush drive plug.
12. Slide the main brush into the brush compartment and onto the drive plug. Make sure the drive slots and keys line up.

NOTE: The bottom of the brush arms should be less than 1 in (25 mm) from the floor. If they are not, turn the brush height adjustment knob to position the arms.

13. Align the main brush idler plug slots with the main brush keys.
14. Slide the main brush idler plug into the main brush tube.
15. Slide the brush idler arm onto the arm hub.
16. Thread the brush idler arm retaining bolt through the idler arm and into the arm hub.
17. Tighten the brush idler arm retaining bolt.

NOTE: If replacing a wire brush, slide the wire brush dolly out from under the wire brush.

18. Close the right side brush access door.
19. Check and adjust the brush pattern as described in To Check and Adjust Main Brush Pattern or To Check and Adjust Wire Brush Pattern.

TO CHECK AND ADJUST MAIN BRUSH PATTERN

1. Apply chalk, or some other material that will not blow away easily, to a smooth, level floor.
2. With the side brush and main brush in the “raised” position, position the main brush over the chalked area.
3. Start the main brush rotating, while keeping a foot on the brakes to keep the machine from moving.
4. Lower the main brush to the floor for 15 to 20 seconds.

NOTE: If no chalk or other material is available, allow the brushes to spin for two minutes.

5. Raise the main brush after it has been spinning on the chalk marks for 15 to 20 seconds.
6. Drive the machine off the test area.
7. Observe the width of the brush pattern. The proper brush pattern width is 2 to 2.5 in (51 to 54 mm).

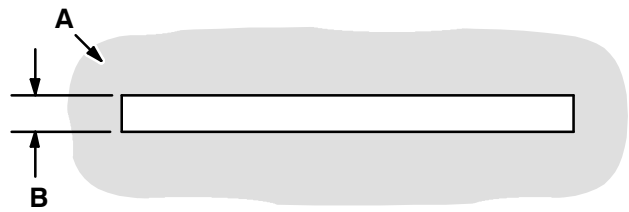

NORMAL MAIN BRUSH PATTERN

00582

- A. Main Brush Pattern**
- B. 2 to 2.5 in (51 to 54 mm)**

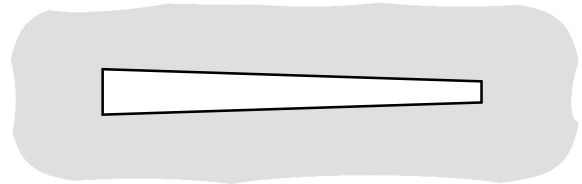

TAPERED MAIN BRUSH PATTERN

00601

If the main brush pattern is tapered, loosen the left main brush cross shaft bearing mounting brackets and bearing flanges. Pivot the bearing mounting bracket to level the cross shaft. Tighten the bearing mounting bracket and the bearing flanges. Check the main brush pattern and readjust as necessary. Then adjust the width of the main brush pattern.

To widen the main brush pattern, loosen the locking wing nut and turn the adjustment knob counterclockwise from the top. To narrow the main brush pattern, loosen the locking wing nut and turn the adjustment knob clockwise from the top.

Tighten the locking wing nut and recheck the main brush pattern. Repeat the procedure until the main brush pattern is within the specified range.

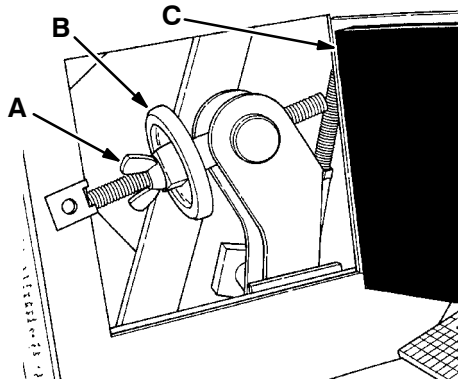

MAIN BRUSH HEIGHT ADJUSTMENT KNOB

- A. Wing Nut
- B. Adjustment Knob
- C. Access Door

TO CHECK AND ADJUST WIRE BRUSH PATTERN

1. Place the brush power lift lever in the “down” position.
2. Stop the engine and engage the machine parking brake.

WARNING: Always stop the machine on a level surface, stop the engine and engage the parking brake before working on the machine to keep it from rolling.

3. Place the main brush lever in the “restricted down” position.
4. Open the right side brush access door.
5. With the brush resting on the floor, adjust the main brush height adjustment knob so the brush just touches the pin in the brush lift bell crank. Tighten the lock nut on the adjustment knob.

NOTE: As the brush wears, the adjustment knob will have to be adjusted to apply proper brush pressure to the floor. Be sure to use the hydraulic pressure gauge. It should read between 1800 and 2200 psi (12,410 and 15,510 kPa).

SIDE BRUSH

The side brush should be inspected daily for wear or damage. Remove any string or wire found tangled on the side brush or side brush drive hub.

The side brush should be replaced when the remaining brush bristle measures 2.5 in (65 mm) in length.

The side brush has four adjustments. The only adjustment which requires regular attention compensates for side brush wear. It is controlled by the side brush height adjustment knob and cable.

To adjust the lowered height, place the side brush in the “lowered” position. Loosen the side brush knob. Slide it forward to lower the side brush, or slide it backward to raise the side brush. Tighten the knob after the desired height is reached.

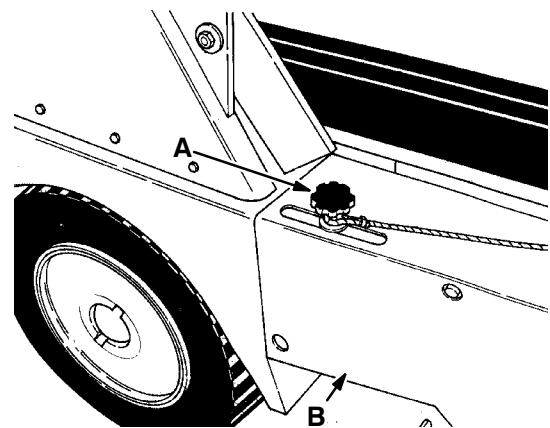

SIDE BRUSH HEIGHT ADJUSTMENT KNOB

- A. Adjustment Knob
- B. Side Brush Bumper

The other three adjustments are the maximum raised height adjustment, the side brush height angle adjustment, and the side brush bumper clearance adjustment. These adjustments should be done after replacing any major component of the side brush lift mechanism and after readjusting the hopper.

TO REPLACE SIDE BRUSH

1. Stop the engine and engage the machine parking brake.

WARNING: Always stop the machine on a level surface, stop the engine, and engage the parking brake before working on the machine to keep it from rolling.

2. Place the side brush in the “raised” position.
3. Remove the side brush retaining bolt from the side brush hub and shaft.

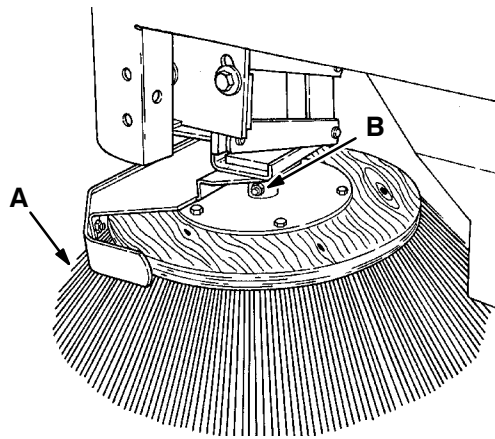

SIDE BRUSH

01460

- A. Side Brush**
- B. Retaining Bolt**

4. Slide the side brush off the side brush drive shaft.
5. Slide the new side brush onto the side brush drive shaft.
6. Insert the side brush retaining bolt through the side brush hub and shaft.
7. Thread a nut onto the threads of the bolt.
8. Tighten the nut and bolt to secure the side brush.
9. Adjust the side brush height as described in Side Brush Height Adjustment.

TO ADJUST SIDE BRUSH MAXIMUM HEIGHT

1. Empty the hopper.
2. Park the machine on a level surface and engage the parking brake.
3. Raise the hopper, engage the hopper support bar, and lower the hopper onto the support bar.
4. Stop the engine.

! WARNING: Always engage the hopper support bar before working under a raised hopper. Do not rely on the machine hydraulic system to keep the hopper in the “raised” position. The hydraulic system may leak internally, allowing the hopper to lower, crushing anything under it.

5. Lower the side brush.

6. Loosen the side brush stop bolts.
7. Position the side brush stop down so the bottom of the side brush is 1 in (25 mm) from the floor when it is in the “raised” position. Tighten the stop bolts.

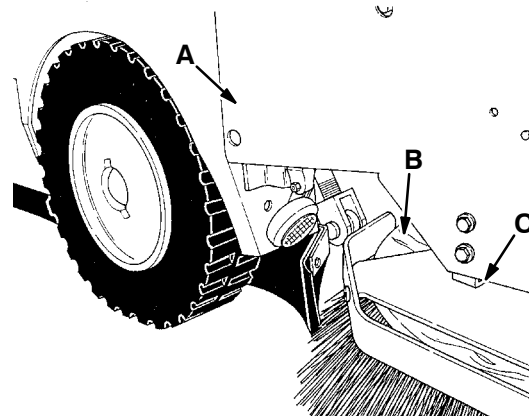

SIDE BRUSH STOP

01498

- A. Bumper**
- B. Side Brush Back**
- C. Stop**

8. Check the side brush raised height.
9. Stop the engine, raise the hopper, disengage the hopper support bar, and lower the hopper.

TO ADJUST SIDE BRUSH ANGLE

1. Raise the side brush.
2. Stop the engine and engage the machine parking brake.

! WARNING: Always stop the machine on a level surface, stop the engine, and engage the parking brake before working on the machine to keep it from rolling.

- Loosen the two side brush angle adjustment bolts.

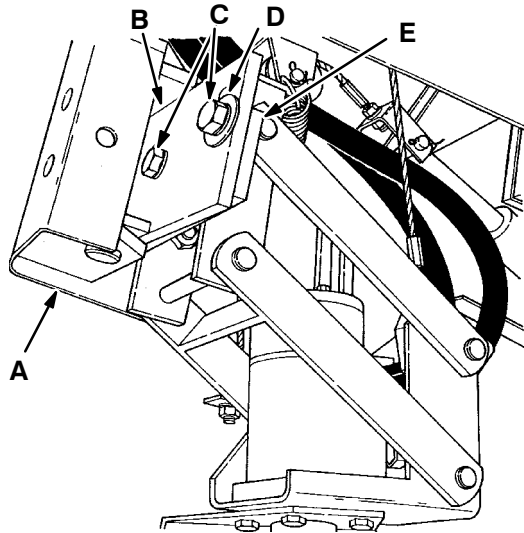

01459

SIDE BRUSH ANGLE ADJUSTMENT

- A. Side Brush Bumper
- B. Side Edge of Brush Pivot
- C. Angle Adjustment Bolt
- D. Adjustment Slot
- E. Side Edge of Brush Suspension Bracket

- Line up the side edges of the side brush pivot and the side brush suspension bracket to set the side brush angle at 5°.

NOTE: The side brush normally operates at a 5° angle. The angle may be changed to a different angle if the application requires.

- Tighten the two side brush angle bolts.

TO ADJUST SIDE BRUSH BUMPER CLEARANCE

- Empty the hopper.
- Park the machine on a level surface and engage the parking brake.
- Raise the hopper, engage the hopper support bar, and lower the hopper onto the support bar.

- Stop the engine.

! WARNING: Always engage the hopper support bar before working under a raised hopper. Do not rely on the machine hydraulic system to keep the hopper in the “raised” position. The hydraulic system may leak internally, allowing the hopper to lower, crushing anything under it.

- Loosen the bumper clearance bolt jam nut and adjust the bolt so there is 2.45 in (60 mm) clearance between the bumper and the side brush assembly. Tighten the jam nut.

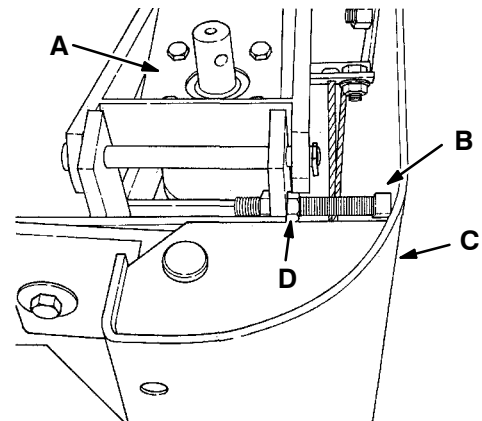

01507

SIDE BRUSH BUMPER CLEARANCE BOLT

- A. Side Brush Assembly
- B. Clearance Bolt
- C. Bumper
- D. Jam Nut

- Start the engine, raise the hopper, disengage the hopper support bar, and lower the hopper.

SKIRTS AND SEALS

HOPPER LIP SKIRTS

The hopper lip skirts are located on the bottom rear of the hopper. Their purpose is to float over debris and help deflect that debris into the hopper. The hopper lip skirts are made up of five bottom lip segments.

The hopper lip skirts should be inspected for wear or damage daily.

TO REPLACE HOPPER LIP

1. Empty the machine debris hopper.
2. Stop the machine on a level surface and engage the machine parking brake.
3. Raise the hopper, engage the hopper support bar, and lower the hopper onto the hopper support bar.

⚠ WARNING: Always engage the hopper support bar before working under a raised hopper. Do not rely on the machine hydraulic system to keep the hopper in the “raised” position. The hydraulic system may leak internally, allowing the hopper to lower, crushing anything under it.

4. Stop the engine.

WARNING: Always stop the machine on a level surface, stop the engine, and engage the parking brake before working on the machine to keep it from rolling.

5. Remove the hopper lip retaining strip mounting bolts.

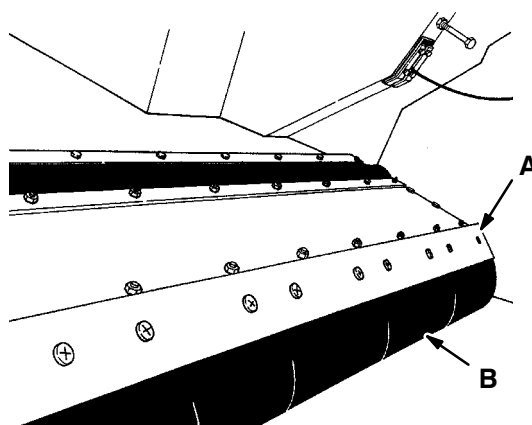

HOPPER LIP SKIRT

01487

- A. Retaining Strip**
B. Hopper Lip Skirts

6. Remove the hopper lip retaining strip and worn or damaged hopper lip segments.
7. Thread the retaining strip mounting bolts through the retaining strip, the hopper lip segments, and into the hopper.
8. Snug the mounting bolts.
9. Start the engine.
10. Raise the hopper, lower the hopper support bar, and lower the hopper.
11. Stop the engine.

HOPPER SIDE SEALS

There are two seals, located on the machine frame, that serve as hopper seals. They are the left and right hopper side seals. The seals should be inspected for wear or damage after every 100 hours of operation.

TO REPLACE HOPPER SIDE SEALS

1. Empty the machine debris hopper.
2. Stop the machine on a level surface and engage the machine parking brake.

3. Raise the hopper, engage the hopper support bar, and lower the hopper onto the hopper support bar.

! WARNING: Always engage the hopper support bar before working under a raised hopper. Do not rely on the machine hydraulic system to keep the hopper in the “raised” position. The hydraulic system may leak internally, allowing the hopper to lower, crushing anything under it.

4. Stop the engine.

! WARNING: Always stop the machine on a level surface, stop the engine, and engage the parking brake before working on the machine to keep it from rolling.

5. Remove the hopper side seal retaining strip mounting bolts.

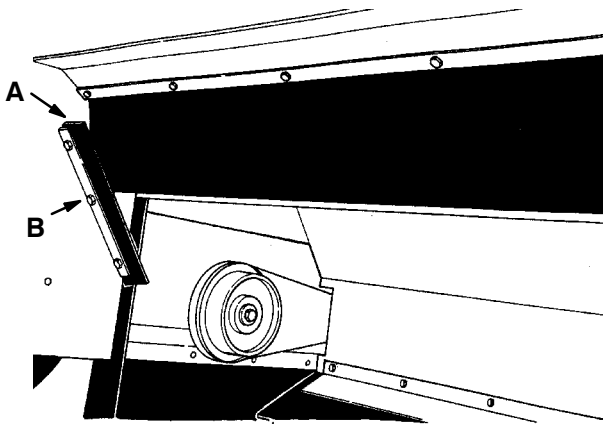

01488

HOPPER SIDE SEALS
A. Hopper Side Seal
B. Seal Retaining Strip

6. Remove the hopper side seal retaining strip and hopper side seal.
7. Thread the retaining strip mounting bolts through the retaining strip, the hopper side seal, and into the machine frame.
8. Tighten the mounting bolts.
9. Start the engine.
10. Raise the hopper, lower the hopper support bar, and lower the hopper.
11. Stop the engine.

BRUSH DOOR SKIRTS

The brush door skirts are located on the bottom of each of the two brush compartment doors. These skirts seal the brush compartment. The seals should be inspected for wear or damage daily.

TO REPLACE AND ADJUST BRUSH DOOR SKIRTS

1. Stop the machine on a smooth, level surface.
2. Stop the engine and engage the machine parking brake.

! WARNING: Always stop the machine on a level surface, stop the engine, and engage the parking brake before working on the machine to keep it from rolling.

3. Open the brush door.
4. Remove the brush door skirt retaining bolts.

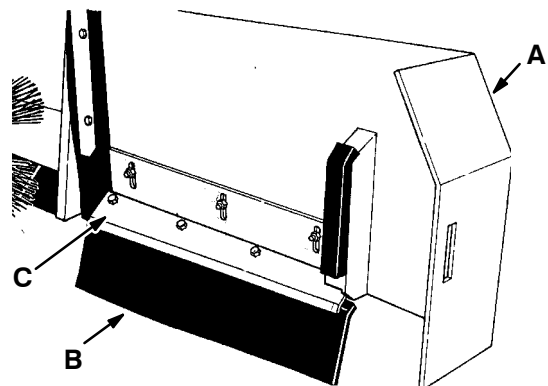

01489

BRUSH DOOR SKIRT

A. Brush Door
B. Brush Door Skirt
C. Skirt Retaining Strip

5. Remove the skirt retaining strip and the door skirt.
6. Position the new door skirt and skirt retaining strip on the brush door.
7. Thread the skirt retaining bolts through the brush door, the door skirt, and into the skirt retaining strip.

NOTE: The brush door skirts have slotted holes to allow for a ground clearance adjustment. The door must be closed for proper adjustment.

8. Slide the brush door skirt up or down so that the skirt clears the floor up to a maximum clearance of 0.12 in (3 mm).
9. Tighten the skirt retaining bolts.
10. Close the brush door.

REAR SKIRTS

The rear skirts are located on the bottom rear of the brush compartment. These skirts seal the brush compartment. The seals should be inspected for wear or damage daily.

TO REPLACE AND ADJUST REAR SKIRTS

1. Stop the machine on a smooth, level surface.
2. Stop the engine and engage the machine parking brake.

! WARNING: Always stop the machine on a level surface, stop the engine, and engage the parking brake before working on the machine to keep it from rolling.

3. Open the two brush compartment doors.

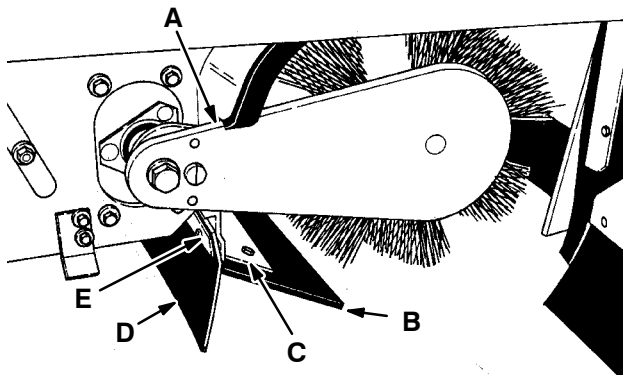

REAR SKIRTS

- A. Brush Idler Arm
- B. Brush Contact Skirt
- C. Skirt Mounting Bracket
- D. Rear Floor Skirt
- E. Skirt Retaining Strip

4. Remove the main brush as described in Main Brush Replacement.
5. Remove the front skirt mounting bracket retaining bolts.
6. Remove the skirt mounting bracket, the rear floor skirt, and the brush contact skirt.
7. Remove the brush contact skirt from the skirt mounting bracket.
8. Mount a new brush contact skirt to the skirt mounting bracket.
9. Position a new floor skirt, floor skirt retaining strip, and the brush contact skirt and mounting bracket on the machine.
10. Thread the skirt mounting bracket retaining bolts through the skirts mounting bracket, the floor contact skirt, the floor contact retaining strip and into the nuts.
11. Slide the rear floor skirt up or down so that the skirt clears the floor up to a maximum clearance of 0.12 in (3 mm).
12. Tighten the retaining bolts.
13. Install the brush as described in Main Brush Replacement.

HOPPER DUST DUMP DOOR SEAL

The hopper dust dump door seal seals the rear opening of the filter cavity. The door opens when the hopper is dumped to allow dust shaken out of the dust filters to exit the filter cavity. The door is made up of a seal and an actuating lever assembly. Check the seal for wear, damage, and adjustment after every 100 hours of operation.

TO REPLACE DUST DUMP DOOR SEAL

1. Empty the hopper.
2. Park the machine on a level surface.

3. Raise the hopper, engage the hopper support support bar, and lower the hopper onto the support bar.

⚠ WARNING: Always engage the hopper support bar before working under a raised hopper. Do not rely on the machine hydraulic system to keep the hopper in the “raised” position. The hydraulic system may leak internally, allowing the hopper to lower, crushing anything under it.

4. Stop the engine and engage the machine parking brake.

⚠ WARNING: Always stop the machine on a level surface, stop the engine, and engage the parking brake before working on the machine to keep it from rolling.

5. Unbolt the seal and seal backing plate from the cross shaft.

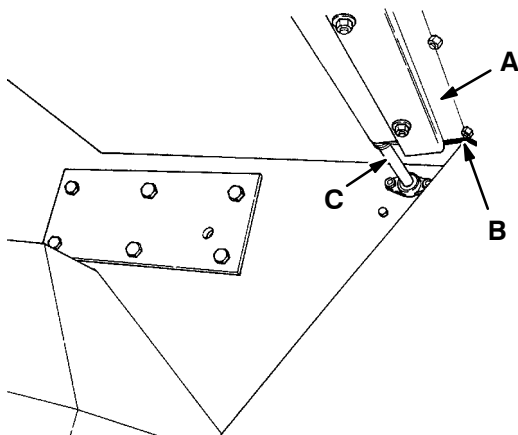

HOPPER DUST DUMP DOOR SEAL

- A. Seal Backing Plate**
- B. Seal**
- C. Cross Shaft**

01506

6. Remove the seal from the seal backing plate.
7. Install a new seal on the backing plate.
8. Bolt the seal and backing plate to the cross shaft.
9. Check the seal adjustment as described in To Adjust Hopper Dust Dump Door.

TO CHECK AND ADJUST HOPPER DUST DUMP DOOR SEAL

1. Empty the hopper.
2. Park the machine on a level surface.
3. Raise the hopper, engage the hopper support bar, and lower the hopper onto the support bar.

⚠ WARNING: Always engage the hopper support bar before working under a raised hopper. Do not rely on the machine hydraulic system to keep the hopper in the “raised” position. The hydraulic system may leak internally, allowing the hopper to lower, crushing anything under it.

4. Stop the engine and engage the machine parking brake.

⚠ WARNING: Always stop the machine on a level surface, stop the engine, and engage the parking brake before working on the machine to keep it from rolling.

5. Check the seal for wear or damage, replace if necessary.
6. Start the engine, raise the hopper, and disengage the hopper support bar.

7. Have an assistant watch the dust dump door cam follower as the hopper lowers. The cam should contact the upper corner and ride on top of the main frame and close the dust dump door.

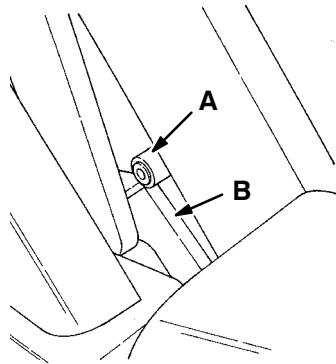

CAM FOLLOWER

01509

- A. Cam Follower
- B. Main Frame

To adjust the cam position, loosen the cam arm stop bolt, adjust the position and retighten. Use care when making adjustments. If the cam strikes the main frame at too low an angle, it may be damaged. If the cam strikes the main frame at too high an angle, the dust dump door will not close fully.

HINGED TOP HOPPER SEAL

The hinged top hopper seal is located on the top of the rear hopper opening. It keeps debris in the hopper while the hopper is being raised to the "dump" position before the hopper dump door is opened. The seal should be inspected for wear or damage after every 100 hours of operation.

TO REPLACE AND ADJUST HINGED TOP HOPPER SEAL

1. Empty the hopper.
2. Stop the machine on a level surface and engage the parking brake.
3. Raise the hopper, engage the hopper support bar, and lower the hopper onto the hopper support bar.

! WARNING: Always engage the hopper support bar before working under a raised hopper. Do not rely on the machine hydraulic system to keep the hopper in the "raised" position. The hydraulic system may leak internally, allowing the hopper to lower, crushing anything under it.

4. Stop the engine.

! WARNING: Always stop the machine on a level surface, stop the engine, and engage the parking brake before working on the machine to keep it from rolling.

5. Remove the stationary hinge bracket bolts to remove the hinged top seal assembly.

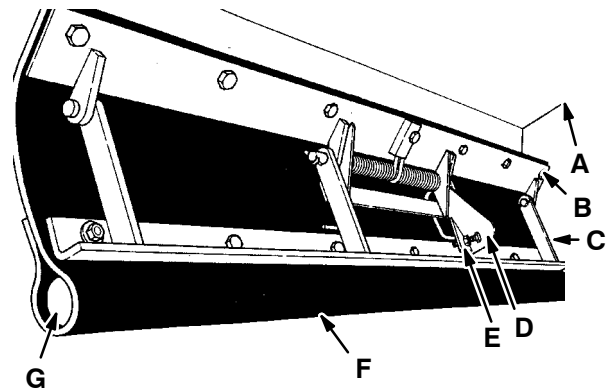

HINGED TOP HOPPER SEAL

01490

- A. Hopper
- B. Stationary Hinge Bracket
- C. Movable Hinge Bracket
- D. Shell Cam
- E. Adjustment Bolt
- F. Top Hopper Seal
- G. Sponge Core

6. Remove the movable hinge bracket bolts to remove the top seal.
7. Mount the new top seal with the sponge core on the movable hinge bracket.
8. Mount the new top seal and stationary hinge bracket to the hopper.
9. Start the engine, raise the hopper, disengage the hopper support bar, and lower the hopper.

10. Open the right brush door.
11. Remove the main brush.
12. Looking through the right brush door opening, check to make sure approximately three-fourths of the top seal is making contact with the machine frame. If three-fourths of the seal is not making contact, raise the hopper, engage the hopper support bar, loosen the shell cam jam nut, and turn the adjustment bolt counterclockwise to increase the amount of contact or clockwise to decrease the amount of contact.

NOTE: If too much of the top hopper seal contacts the machine frame, the hopper may not be able to seat in the "operating" position, causing poor debris pickup.

Tighten the jam nut, raise the hopper, disengage the hopper support bar, lower the hopper and recheck the seal contact. Repeat the procedure as necessary.

HOPPER DOOR HINGE SEAL

The hopper door hinge seal seals the area between the hopper door and the hopper. Check the seal for wear or damage after every 100 hours of operation.

TO REPLACE HOPPER DOOR HINGE SEAL

1. Empty the hopper.
2. Stop the machine on a level surface and engage the parking brake.
3. Raise the hopper, engage the hopper support bar, and lower the hopper onto the hopper support bar.

⚠ WARNING: Always engage the hopper support bar before working under a raised hopper. Do not rely on the machine hydraulic system to keep the hopper in the "raised" position. The hydraulic system may leak internally, allowing the hopper to lower, crushing anything under it.

4. Stop the engine.

⚠ WARNING: Always stop the machine on a level surface, stop the engine, and engage the parking brake before working on the machine to keep it from rolling.

5. Remove the two seal retainers and the old hinge seal.

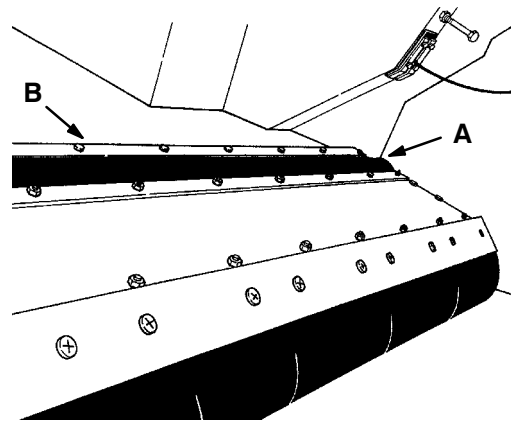

HOPPER DOOR HINGE SEAL

01487

- A. Hinge Seal**
- B. Seal Retainer**

6. Position the new seal between the hopper door and the hopper.
7. Secure the seal with the seal retainers and hardware.
8. Start the engine, raise the hopper, disengage the hopper support bar, and lower the hopper.

BRAKES AND TIRES

SERVICE BRAKES

The service brakes are hydraulically activated by a master brake cylinder. Check the master brake cylinder fluid level after every 400 hours of operation and add brake fluid as needed. The master brake cylinder is located at the front of the machine, behind the hopper.

If necessary, adjust the brake clevis on the master cylinder push rod so that the brake pedal is in a horizontal position when the cylinder push rod starts to engage the cylinder piston.

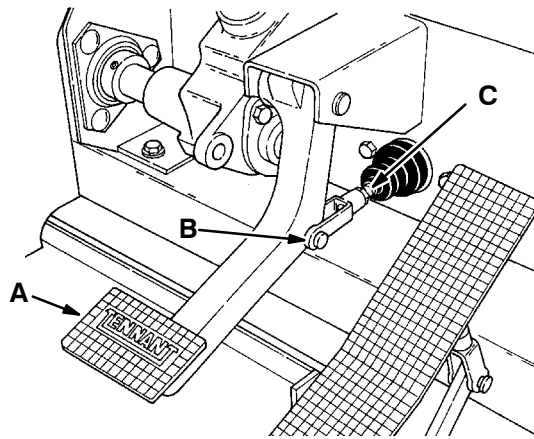

BRAKE PEDAL

01495

- A. Brake Pedal**
- B. Brake Clevis**
- C. Master Cylinder Push Rod**

Brakes require bleeding whenever air enters the system, lowering the effective braking pressure. Air can enter when the master cylinder or wheel cylinders are serviced or if the fluid in the reservoir runs dry. Air can also enter through a leaky brake line or hose. Find the leaking line and replace it before bleeding the system.

Whenever handling brake fluid, do not get any on the brake pads, brake drums, or body paint. Brake pads will be permanently damaged, requiring replacement. Body paint can be damaged also unless you wipe the area with a clean cloth and wash it with soapy solution immediately.

1. Make sure that the brake fluid reservoir is full and that the vent in the cap is open.
2. Connect a plastic or rubber tube to the bleeder valve on the left front wheel. Suspend the other end of the tube in a jar or bottle filled with a few inches of brake fluid. During the remaining steps, keep this end submerged at all times and never let the level in the brake fluid reservoir drop below one half full.
3. Open the bleeder valve on the left front wheel about one turn. Have an assistant press the brake pedal slowly to the floor. As soon as the pedal is all the way down, close the bleeder valve and let the pedal up. Repeat this step as many times as necessary, until fluid, free of air bubbles, exits from the tube.
4. Bleed the right front wheel in the same manner as described in the steps above. Keep checking the brake fluid reservoir to be sure it doesn't run out of fluid.
5. When all wheels are bled, discard the brake fluid in the jar or bottle; never reuse such fluid.
6. Top up the brake fluid reservoir with clean fluid.

PARKING BRAKES

The parking brakes are mechanically activated by the parking brake lever and two cables.

The parking brakes should be adjusted whenever the machine rolls after engaging the parking brake, or when it becomes very easy to engage the parking brake, and after every 50 hours of operation. The parking brake may be routinely tightened by turning the knurled knob on the end of the parking brake clockwise. If the knob adjustment is inadequate, fully loosen the knob, loosen the brake cable mounting nuts, thread the lower nuts closer to the end of the cable, and retighten the top nuts. Be sure to thread the nuts out the same number of turns. Adjust the parking brake enough to make the parking brake slightly resist being engaged.

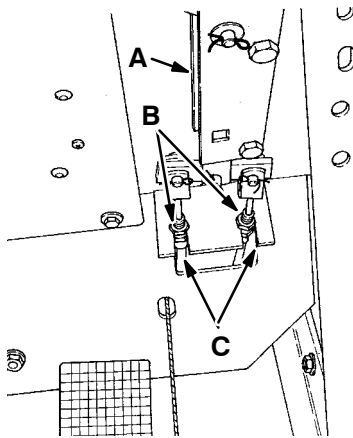

PARKING BRAKE

01496

- A. Parking Brake**
- B. Cable Nut**
- C. Brake Cable**

TIRES

The front machine tires are solid and require no regular maintenance.

The rear machine tire is solid and requires no regular maintenance.

SECTION 4 APPENDIX

CONTENTS

	Page
Hardware Information	4-1
Standard Bolt Torque Chart	4-1
Metric Bolt Torque Chart	4-1
Bolt Identification	4-1
Thread Sealant and Locking Compounds	4-1
Hydraulic Fitting Information	4-2
Hydraulic Tapered Pipe Fitting (NPT) Torque Chart	4-2
Hydraulic Tapered Seat Fitting (JIC) Torque Chart	4-2
Hydraulic O-Ring Fitting Torque Chart	4-2

HARDWARE INFORMATION

The following charts state standard plated hardware tightening ranges for normal assembly applications. Decrease the specified torque by 20% when using a thread lubricant. Do not substitute lower grade hardware for higher grade hardware. If higher grade hardware than specified is substituted, tighten only to the specified hardware torque value to avoid damaging the threads of the part being threaded into, as when threading into speed nuts or weldments.

STANDARD BOLT TORQUE CHART

Thread Size	SAE Grade 5 Torque ft lb (Nm)	SAE Grade 8 Torque ft lb (Nm)
0.25 in	7–10 (9–14)	10–13 (14–18)
0.31 in	15–20 (20–27)	20–26 (27–35)
0.38 in	27–35 (37–47)	36–47 (49–64)
0.44 in	43–56 (58–76)	53–76 (72–103)
0.50 in	65–85 (88–115)	89–116 (121–157)
0.62 in	130–170 (176–231)	117–265 (159–359)
0.75 in	215–280 (291–380)	313–407 (424–552)
1.00 in	500–650 (678–881)	757–984 (1026–1334)





NOTE: Decrease torque by 20% when using a thread lubricant.

METRIC BOLT TORQUE CHART

Thread Size	Class 8.8 Torque ft lb (Nm)	Class 10.9 Torque ft lb (Nm)
M4	2 (3)	3 (4)
M5	4 (5)	6 (8)
M6	7 (9)	10 (14)
M8	18 (24)	25 (34)
M10	32 (43)	47 (64)
M12	58 (79)	83 (112)
M14	94 (127)	133 (180)
M16	144 (195)	196 (265)
M20	260 (352)	336 (455)
M24	470 (637)	664 (900)

NOTE: Decrease torque by 20% when using a thread lubricant.

BOLT IDENTIFICATION

Identification Grade Marking	Specification and Grade
	SAE–Grade 5
	SAE–Grade 8
	ISO–Grade 8.8
	ISO–Grade 10.9

01395

THREAD SEALANT AND LOCKING COMPOUNDS

Thread sealants and locking compounds may be used on this machine. They include the following:

Loctite 515 sealant – gasket forming material. TENNANT® Part No. 75567, 15 oz (440 ml) cartridge.

Loctite 242 blue – medium strength thread locking compound. TENNANT® Part No. 32676, 0.5 ml tube.

Loctite 271 red – high strength thread locking compound. TENNANT® Part No. 19857, 0.5 ml tube.

HYDRAULIC FITTING INFORMATION

HYDRAULIC TAPERED PIPE FITTING (NPT) TORQUE CHART

NOTE: Ratings listed are when using teflon thread seal.

Size	Minimum Torque	Maximum Torque
1/4 NPT	10 ft lb (14 Nm)	30 ft lb (41 Nm)
1/2 NPT	25 ft lb (34 Nm)	50 ft lb (68 Nm)
3/4 NPT	50 ft lb (68 Nm)	100 ft lb (136 Nm)

HYDRAULIC TAPERED SEAT FITTING (JIC) TORQUE CHART

Tube O.D. (in)	Thread Size	Maximum Torque
0.25	0.44-20	9 ft lb (12 Nm)
0.38	0.56-18	20 ft lb (27 Nm)
0.50	0.75-16	30 ft lb (41 Nm)
0.62	0.88-14	40 ft lb (54 Nm)
0.75	1.12-12	70 ft lb (95 Nm)
1.0	1.31-12	90 ft lb (122 Nm)

HYDRAULIC O-RING FITTING TORQUE CHART

Tube O.D.(in)	Thread Size	Minimum Torque	Maximum Torque
0.25	0.44-20	6 ft lb (8 Nm)	9 ft lb (12 Nm)
0.38	0.56-18	13 ft lb (18 Nm) *10 ft lb (14 Nm)	20 ft lb (27 Nm) 12 ft lb (16 Nm)
0.50	0.75-16	20 ft lb (27 Nm) *21 ft lb (28 Nm)	30 ft lb (41 Nm) 24 ft lb (33 Nm)
0.62	0.88-14	25 ft lb (34 Nm)	40 ft lb (54 Nm)
0.75	1.12-12	45 ft lb (61 Nm)	70 ft lb (95 Nm)
1.0	1.31-12	60 ft lb (81 Nm)	90 ft lb (122 Nm)

NOTE: Do not use sealant on o-ring threads.

*Aluminum bodied components