

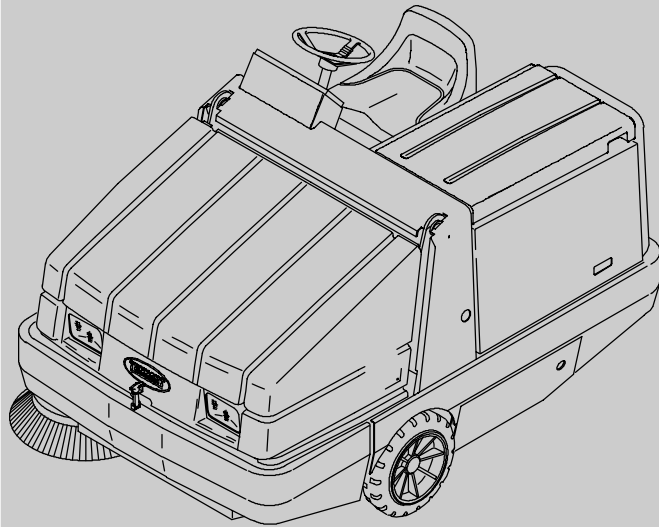

6600

(Gas/LPG)

Sweeper Operator Manual



North America / International

www.tennantco.com

330950
Rev. 05 (03-2008)





This manual is furnished with each new model. It provides necessary operation and maintenance instructions.

Read this manual completely and understand the machine before operating or servicing it.

This machine will provide excellent service. However, the best results will be obtained at minimum costs if:

- The machine is operated with reasonable care.
- The machine is maintained regularly - per the machine maintenance instructions provided.
- The machine is maintained with manufacturer supplied or equivalent parts.

	PROTECT THE ENVIRONMENT Please dispose of packaging materials, old machine components including batteries, hazardous fluids such as antifreeze and oil, in an environmentally safe way according to local waste disposal regulations.
	Always remember to recycle.

MACHINE DATA	
Please fill out at time of installation for future reference.	
Model No. -	_____
Serial No. -	_____
Machine Options -	_____
Sales Rep. -	_____
Sales Rep. phone no. -	_____
Customer Number -	_____
Installation Date -	_____

Tennant Company
PO Box 1452
Minneapolis, MN 55440
Phone: (800) 553-8033 or (763) 513-2850
www.tennantco.com



CALIFORNIA PROPOSITION 65 WARNING:

Engine exhaust from this product contains chemicals known to the State of California to cause cancer, birth defects, or other reproductive harm.

Thermo-Sentry, II-Speed, Perma-Filter, 1 Step, Duramer, Vario Sweeping Brush, and VCS are US registered trademarks of Tennant Company.

Specifications and parts are subject to change without notice.

Original instructions, Copyright © 2003-2008 TENNANT Company, Printed in U.S.A.

CONTENTS

	Page		Page
SAFETY PRECAUTIONS	3	HOW THE MACHINE WORKS	37
OPERATION	6	PRE-OPERATION CHECKLIST	37
OPERATOR RESPONSIBILITY	6	CHANGING AN LPG FUEL TANK	38
MACHINE COMPONENTS	8	STARTING THE MACHINE	40
CONTROL PANEL SYMBOLS	9	SWEEPING AND BRUSH INFORMATION	42
CONTROLS AND INSTRUMENTS	11	SWEEPING	43
OPERATION OF CONTROLS	12	STOP SWEEPING	45
DIRECTIONAL PEDAL	12	EMPTYING THE HOPPER	47
BRAKE PEDAL	13	STOP THE MACHINE	50
PARKING BRAKE LEVER	13	POST-OPERATION CHECKLIST	52
MAIN BRUSH AND SIDE		ENGAGING HOPPER SUPPORT BAR ..	53
BRUSH LEVER	14	DISENGAGING HOPPER SUPPORT BAR	55
HOPPER DOOR LEVER	15	OPERATION ON INCLINES	56
HOPPER LIFT LEVER	16	OPTIONS	57
MAIN BRUSH POSITION LEVER	17	VACUUM WAND	57
HORN BUTTON	17	BLOWER WAND	62
MAIN BRUSH ADJUSTMENT KNOB ..	18	HEATER VALVE	63
TURN SIGNAL SWITCH (OPTION) ...	19	MACHINE TROUBLESHOOTING	64
HOPPER TEMPERATURE LIGHT -		MAINTENANCE	66
THERMO SENTRY	20	MAINTENANCE CHART	66
CHARGING SYSTEM LIGHT	20	LUBRICATION	68
HOPPER DOOR LIGHT	20	ENGINE	68
ENGINE OIL PRESSURE LIGHT	21	REAR WHEEL SUPPORT	68
LPG FUEL LIGHT	21	HOPPER BEARINGS	69
CLOGGED FILTER LIGHT	22	FRONT WHEEL BEARINGS	69
CHECK ENGINE LIGHT	22	HYDRAULICS	70
HIGH ENGINE TEMPERATURE LIGHT	22	HYDRAULIC FLUID RESERVOIR	70
HOURMETER	23	HYDRAULIC FLUID	70
FUEL LEVEL GAUGE	23	HYDRAULIC HOSES	71
OPERATING/HAZARD LIGHTS		PROPELLING MOTOR	71
SWITCH	24	ENGINE	72
VACUUM FAN/FILTER SHAKER		COOLING SYSTEM	72
SWITCH	24	AIR FILTER	73
ENGINE SPEED SWITCH	25	TO REPLACE AIR FILTER	74
STEERING WHEEL	26	FUEL FILTER (GASOLINE)	74
STEERING COLUMN TILT LEVER		FUEL FILTER (LPG)	75
(OPTION)	26	ELECTRONIC PRESSURE REGULATOR	
IGNITION SWITCH	27	(LPG) (For machines serial number	
SIDE BRUSH POSITION LEVER	28	030000 and above)	75
SIDE BRUSH DOWN PRESSURE		ELECTRONIC FUEL INJECTION (EFI)	76
KNOB	29	SPARK PLUGS	76
FUSES	30	VALVE TAPPET CLEARANCE	76
CIRCUIT BREAKERS (OPTION)	31	CRANKCASE VENTILATION SYSTEM	76
LATCHES	32	TIMING BELT	76
HOPPER SUPPORT BAR	33	BATTERY	77
OPERATOR SEAT	33	BELTS AND CHAINS	77
DELUXE SUSPENSION SEAT		ENGINE FAN BELT	77
(OPTION)	34	STATIC DRAG CHAIN	77
HEATER KNOB (OPTION)	35	DEBRIS HOPPER	78
AIR CONDITIONING SWITCH		HOPPER DUST FILTER	78
(OPTION)	35	TO REPLACE HOPPER	
WINDSHIELD WIPER SWITCH		DUST FILTER	79
(OPTION)	35	THERMO SENTRY	81
DOME LIGHT SWITCH (OPTION)	36		
PRESSURIZER SWITCH (OPTION) ..	36		

CONTENTS

	Page
BRUSHES	82
MAIN BRUSH	82
TO REPLACE MAIN BRUSH	83
TO CHECK AND ADJUST MAIN BRUSH PATTERN	84
SIDE BRUSH	86
TO REPLACE SIDE BRUSH	87
SIDE BRUSH GUARD	87
SKIRTS AND SEALS	88
HOPPER LIP SKIRTS	88
HOPPER SIDE SKIRT	88
BRUSH DOOR SKIRTS	88
REAR SKIRTS	89
SIDE BRUSH DUST CONTROL SKIRTS (OPTION)	89
BRUSH DOOR SEALS	89
HOPPER SEALS	90
HOPPER DOOR SEALS	90
HOPPER FILTER SEALS	91
HOPPER INSPECTION DOOR SEAL ..	91
VACUUM WAND DOOR SEALS (OPTION)	91
BRAKES AND TIRES	92
SERVICE BRAKES	92
PARKING BRAKE	92
TIRES	92
REAR WHEEL	92
PUSHING, TOWING, AND TRANSPORTING THE MACHINE	93
PUSHING OR TOWING THE MACHINE	93
TRANSPORTING THE MACHINE	93
MACHINE JACKING	96
STORING MACHINE	96
SPECIFICATIONS	97
GENERAL MACHINE DIMENSIONS/CAPACITIES	97
GENERAL MACHINE PERFORMANCE ..	97
TIRES	97
POWER TYPE	98
STEERING	98
HYDRAULIC SYSTEM	98
BRAKING SYSTEM	98
MACHINE DIMENSIONS	99
INDEX	101

SAFETY PRECAUTIONS

The following precautions are used throughout this manual as indicated in their description:

 **WARNING:** To warn of hazards or unsafe practices which could result in severe personal injury or death.

 **CAUTION:** To warn of unsafe practices that could result in minor or moderate personal injury.

FOR SAFETY: To identify actions which must be followed for safe operation of equipment.

The machine is suited to sweep disposable debris. Do not use the machine other than described in this Operator Manual. The machine is not designed for use on public roads.

The following information signals potentially dangerous conditions to the operator or equipment:

 **WARNING:** Engine emits toxic gases. Severe respiratory damage or asphyxiation can result. Provide adequate ventilation. Consult with your regulatory authorities for exposure limits. Keep engine properly tuned.

 **WARNING:** Raised hopper may fall. Engage hopper support bar.

 **WARNING:** Lift arm pinch point. Stay clear of hopper lift arms.

 **WARNING:** Moving belt and fan. Keep away.

 **WARNING:** Accident may occur. Do not operate vacuum or blower wand while driving.

 **WARNING:** Hot surface. keep away

 **CAUTION:** LPG engine will run for a few seconds after key is turned off. Apply parking brake before leaving machine.

FOR SAFETY:

1. **Do not operate machine:**
 - Unless trained and authorized.
 - Unless operator manual is read and understood.
 - If it is not in proper operating condition.
 - In flammable or explosive areas unless designed for use in those areas.
 - In areas with possible falling objects unless equipped with overhead guard.
2. **Before starting machine:**
 - Check for fuel, oil, and liquid leaks.
 - Keep sparks and open flame away from refueling area.
 - Make sure all safety devices are in place and operate properly.
 - Check brakes and steering for proper operation.
3. **When starting machine:**
 - Keep foot on brake and directional pedal in neutral.
4. **When using machine:**
 - Do not pick up burning or smoking debris, such as cigarettes, matches, or hot ashes.
 - Use brakes to stop machine.
 - Go slow on inclines and slippery surfaces.
 - Use care when reversing machine.
 - Move machine with care when hopper is raised.
 - Make sure adequate clearance is available before raising hopper.
 - Do not carry passengers on machine.
 - Always follow safety and traffic rules.
 - Report machine damage or faulty operation immediately.
5. **Before leaving or servicing machine:**
 - Stop on level surface.
 - Set parking brake.
 - Turn off machine and remove key.

SAFETY PRECAUTIONS

- 6. When servicing machine:**
 - **Avoid moving parts. Do not wear loose jackets, shirts, or sleeves.**
 - **Block machine tires before jacking machine up.**
 - **Jack machine up at designated locations only. Block machine up with jack stands.**
 - **Use hoist or jack that will support the weight of the machine.**
 - **Wear eye and ear protection when using pressurized air or water.**
 - **Disconnect battery connections before working on machine.**
 - **Avoid contact with battery acid.**
 - **Avoid contact with hot engine coolant.**
 - **Allow engine to cool.**
 - **Keep flames and sparks away from fuel system service area. Keep area well ventilated.**
 - **Use cardboard to locate leaking hydraulic fluid under pressure.**
 - **Use TENNANT supplied or approved replacement parts.**

- 7. When loading/unloading machine onto/off truck or trailer:**
 - **Turn off machine.**
 - **Use truck or trailer that will support the weight of the machine.**
 - **Use winch. Do not drive the machine onto/off the truck or trailer unless the load height is 380 mm (15 in) or less from the ground.**
 - **Set parking brake after machine is loaded.**
 - **Block machine tires.**
 - **Tie machine down to truck or trailer.**

The following safety labels are mounted on the machine in the locations indicated. If these or any label becomes damaged or illegible, install a new label in its place.

EMISSIONS LABEL - LOCATED ON THE SIDE PANEL OF THE OPERATOR COMPARTMENT.



ENGINE FAN AND BELT LABEL - LOCATED ON THE RADIATOR SHROUD.



BURN HAZARD LABEL - LOCATED ON THE REAR OF THE FRAME.



LPG ENGINE WILL RUN LABEL - LOCATED ON THE SIDE OF THE INSTRUMENT PANEL.

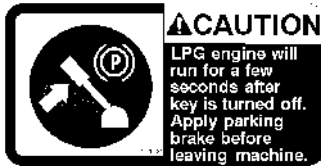

FOR SAFETY LABEL - LOCATED ON THE SIDE PANEL OF THE OPERATOR COMPARTMENT.

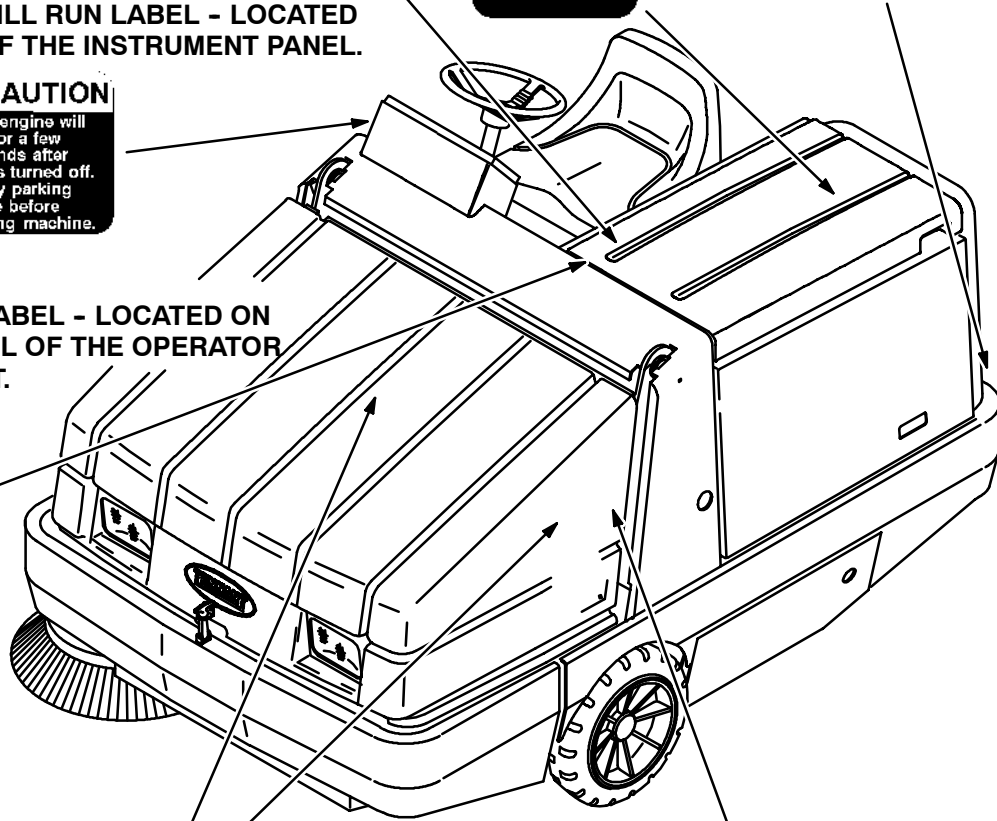

HOPPER SUPPORT BAR LABEL - LOCATED ON THE HOPPER SUPPORT BAR AND ON BOTH HOPPER LIFT ARMS.



HOPPER LIFT ARMS LABEL - LOCATED ON BOTH HOPPER LIFT ARMS.

OPERATOR RESPONSIBILITY

- The operator's responsibility is to take care of the daily maintenance and checkups of the machine to keep it in good working condition. The operator must inform the service mechanic or supervisor when the required maintenance intervals occur as stated in the *MAINTENANCE* section of this manual.

- Read this manual carefully before operating this machine.

FOR SAFETY: Do not operate machine, unless operation manual is read and understood.

- Check the machine for shipping damage. Check to make sure machine is complete per shipping instructions.
- Check the hydraulic fluid level in the hydraulic reservoir.
- Check the engine oil level.
- Check the radiator coolant level.

FOR SAFETY: When servicing machine, avoid contact with hot engine coolant.

- Gasoline powered machines: Fill the fuel tank.

FOR SAFETY: When servicing machine, keep flames and sparks away from fuel system service area. Keep area well ventilated.

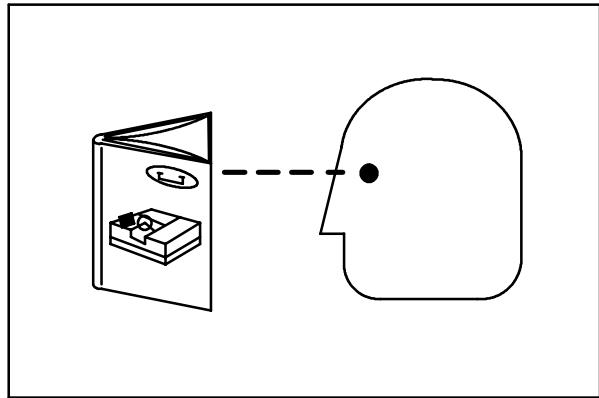

07324

- LPG powered machines: Install the LPG fuel tank on the machine. See *CHANGING AN LPG FUEL TANK*.

FOR SAFETY: When servicing machine, keep flames and sparks away from fuel system service area. Keep area well ventilated.

- After the first 50 hours of operation, follow the recommended procedures stated in the *MAINTENANCE CHART*.
- Keep your machine regularly maintained by following the maintenance information in this manual. We recommend taking advantage of a regularly scheduled service contract from your TENNANT representative.
- Order parts and supplies directly from your authorized TENNANT representative. Use the parts manual provided when ordering parts.

OPERATION

MACHINE COMPONENTS

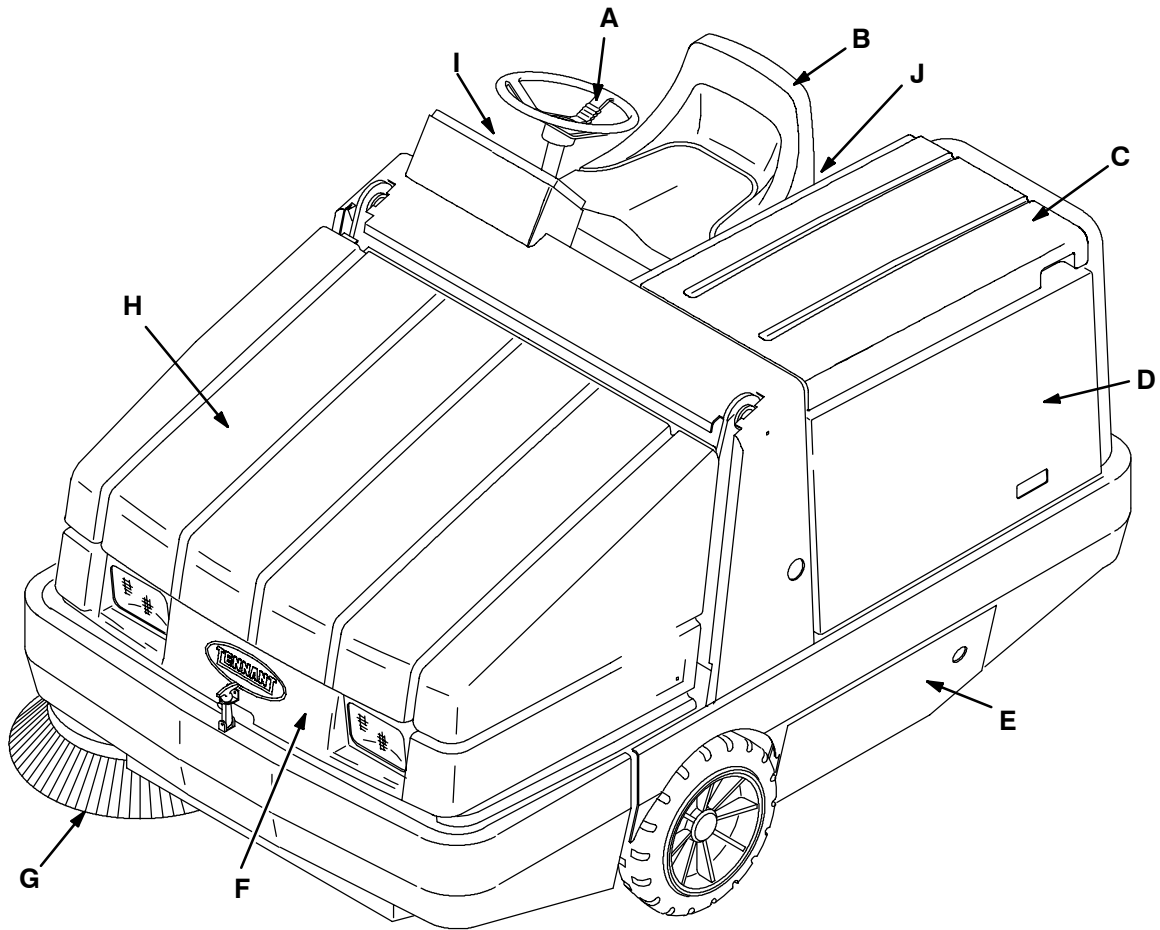

- A. Steering Wheel
- B. Operator Seat
- C. Engine Cover
- D. Engine Side Door
- E. Main Brush Access Door
- F. Hopper Access Cover
- G. Side Brush
- H. Hopper Cover
- I. Instrument Panel
- J. Fuel Tank

354000

CONTROL PANEL SYMBOLS

These symbols identify controls and displays on the machine:



Main and Side Brushes On



Charging System



Main Brush On



Engine Oil Pressure



Hopper Door Open



Check Engine



Hopper Door Close



Hopper Temperature - Thermo Sentry



Hopper Down



Filter Clogged



Hopper Up



Hopper Door Closed



Horn



LPG Fuel



Main Brush Down Pressure Light



Hourmeter



Main Brush Down Pressure Heavy



Hazard Light



Main Brush Float



Filter Shaker



Main Brush Down



Operating Lights



Main Brush Up



Fan

OPERATION



Side Brush Down Pressure Light



Side Brush Down



Side Brush Down Pressure Heavy



Side Brush Up



Windshield Wiper Slow



High Engine Temperature



Windshield Wiper Fast



Dome Light



Heater



Cab Pressurizer Slow



Cab Pressurizer Fast



Engine speed (idle)



Engine speed (slow)



Engine speed (fast)

CONTROLS AND INSTRUMENTS

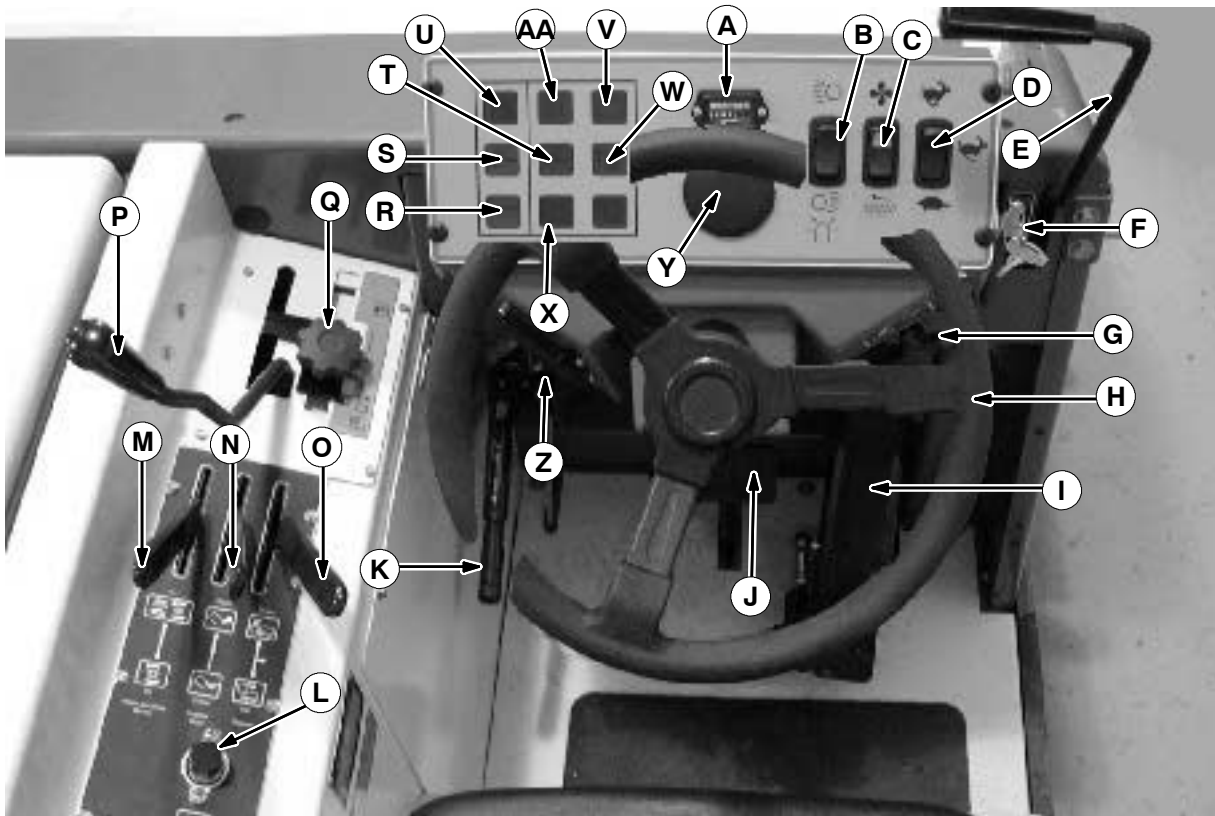

- A. Hourmeter
- B. Operating/Hazard Lights Switch
- C. Vacuum Fan/Filter Shaker Switch
- D. Engine Speed Switch
- E. Side Brush Position Lever
- F. Ignition Switch
- G. Side Brush Down Pressure Knob
- H. Steering Wheel
- I. Directional Pedal
- J. Brake Pedal
- K. Parking Brake Lever
- L. Horn Button
- M. Main Brush And Side Brush Lever
- N. Hopper Door Lever
- O. Hopper Lift Lever
- P. Main Brush Position Lever
- Q. Main Brush Adjustment Knob
- R. Clogged Filter Light (Option)
- S. Hopper Door Light
- T. Engine Oil Pressure Light (For Machines Serial Number 024999 And Below)
- U. Hopper Temperature Light - Thermo Sentry
- V. Charging System Light
- W. LP Fuel Light
- X. Check Engine Light
- Y. Fuel Gauge (Gasoline Machines Only)
- Z. Fuses
- AA. High Engine Temperature Light (For Machines Serial Number 025000 and Above)

OPERATION

OPERATION OF CONTROLS

DIRECTIONAL PEDAL

The *directional pedal* controls direction of travel and the propelling speed of the machine. You change the speed of the machine with the pressure of your foot; the harder you press the faster the machine travels.

Forward: Press the top of the *directional pedal* with the toe of your foot.



Reverse: Press the bottom of the *directional pedal* with the heel of your foot.



Neutral: Take your foot off the *directional pedal* and it will return to the neutral position.



The toe angle of the optional directional pedal is adjustable. Remove the clevis pin, move the top of the pedal to the angle needed, and put the clevis pin through the adjustment holes.



BRAKE PEDAL

The *brake pedal* stops the machine.

Stop: Take your foot off the directional pedal and let it return to the neutral position. Step on the brake pedal.



PARKING BRAKE LEVER

The *parking brake lever* sets and releases the front wheel brakes.

Set: Pull the *parking brake lever* up.

FOR SAFETY: Before leaving or servicing machine; stop on level surface, set parking brake, turn off machine and remove key.

Release: Push the *parking brake lever* down.

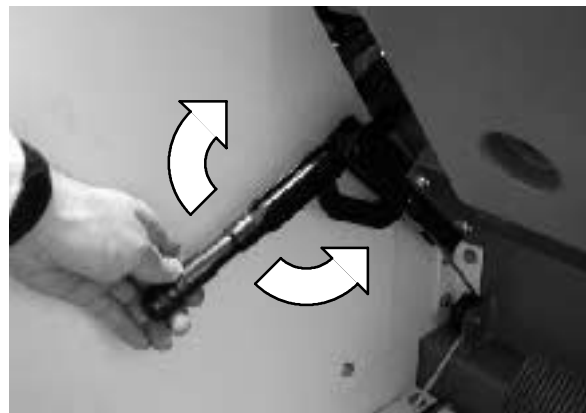

OPERATION

MAIN BRUSH AND SIDE BRUSH LEVER

The *main brush and side brush lever* controls the main brush and side brush rotation.

Main Brush and Side Brush On: Push the *main brush and side brush lever* into the **On** position.

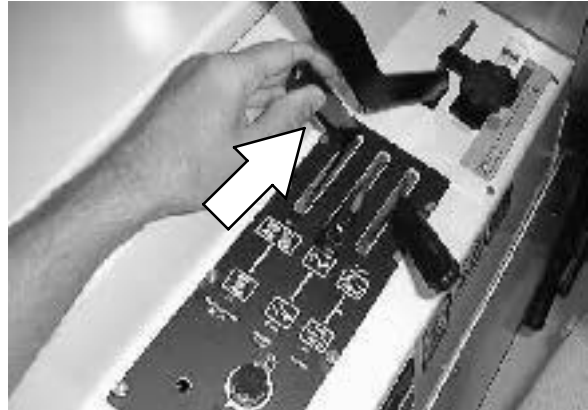

Main Brush and Side Brush Off: Pull the *main brush and side brush lever* into the middle position.

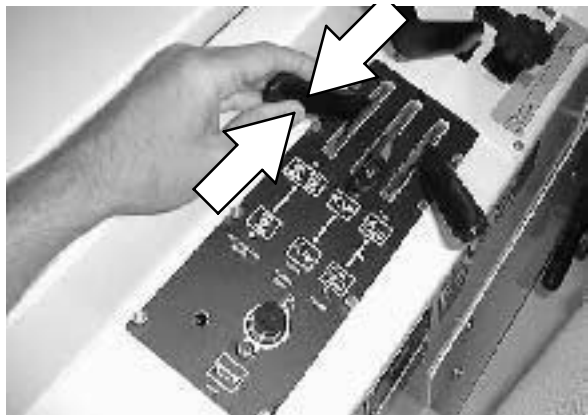

Main Brush On: Pull the *main brush and side brush lever* into the **On** position.

NOTE: Always raise the main brush when the machine is not being operated for some time. This prevents the main brush from getting a flat spot.



HOPPER DOOR LEVER

The *hopper door lever* opens and closes the hopper door and dust door. Open the hopper door when sweeping. Close the hopper door when emptying the hopper to control debris and dust.

Open: Push the *hopper door lever* into the **Open** position and leave it there.



Hold: Release the *hopper door lever* into the middle position.



Close: Pull and hold the *hopper door lever* into the **Close** position.

NOTE: The hopper door will not close if the main brush, side brush, and vacuum fan are operating.



OPERATION

HOPPER LIFT LEVER

The *hopper lift lever* raises and lowers the hopper.

Up: Pull and hold the *hopper lift lever* into the **Up** position.

 **WARNING: Raised hopper may fall.**
Engage hopper support bar.

NOTE: The hopper will not raise if the main brush, side brush, and vacuum fan are operating.

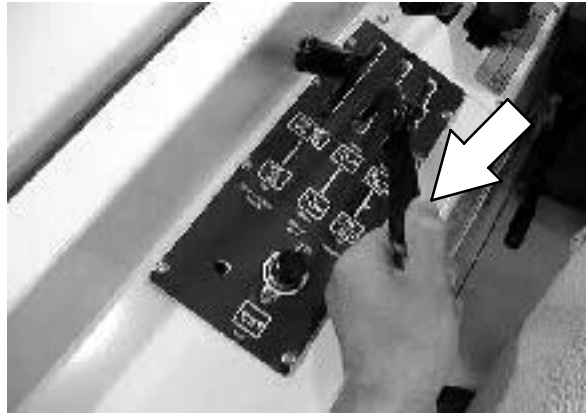

Hold: Release the *hopper lift lever* up and into the middle position.

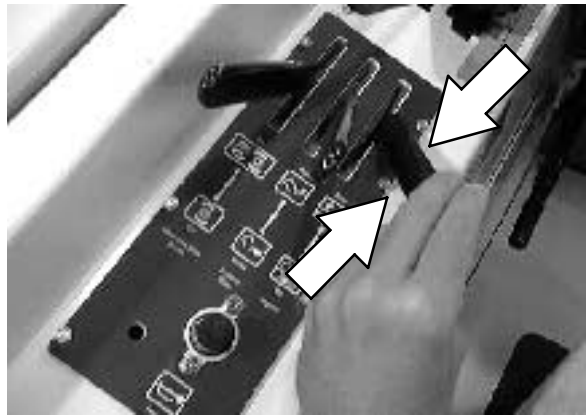

Down: Push and hold the *hopper lift lever* into the **Down** position.



MAIN BRUSH POSITION LEVER

The *main brush position lever* lowers and raises the main brush. The main brush can be lowered into one sweeping position, which is set by the main brush adjustment knob.

Down: Pull the *main brush position lever* back and to the left. Release the lever forward into the down position.

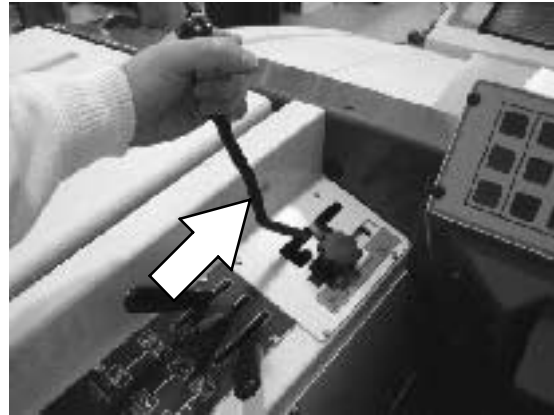

Up: Pull the *main brush position lever* all the way back and to the right. Release the lever forward into the **Up** position.

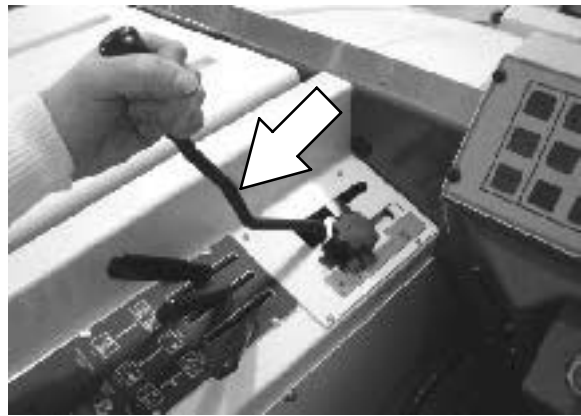

HORN BUTTON

The *horn button* operates the horn.

Sound: Press the button.

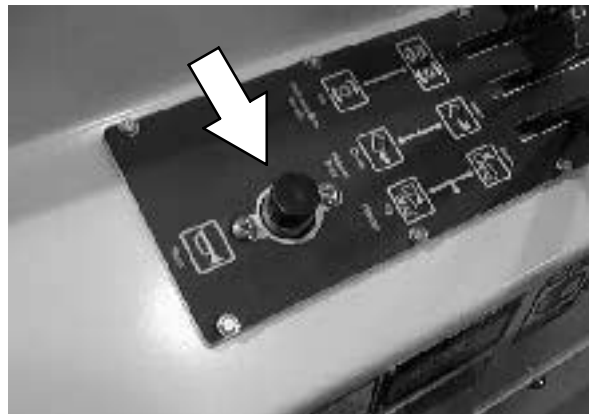

OPERATION

MAIN BRUSH ADJUSTMENT KNOB

The *main brush adjustment knob* controls the amount of contact the main brush has with the sweeping surface.

Note the length of the main brush bristles with the color band on the brush idler plate before moving the *main brush adjustment knob*.

Align the pointer from the plate located under the knob, to match the same color band as the brush idler plate.

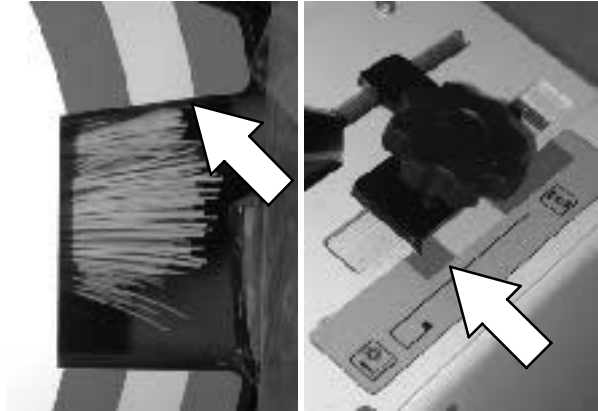

Loosen adjustment knob: Turn the adjustment plate knob counter-clockwise until the plate can slide along the adjustment panel.

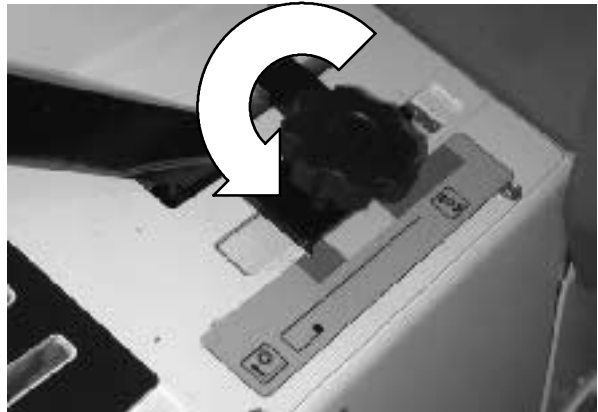

Secure adjustment knob: Turn the adjustment plate knob clockwise until the knob is hand tight and the plate cannot slide in the adjustment panel.

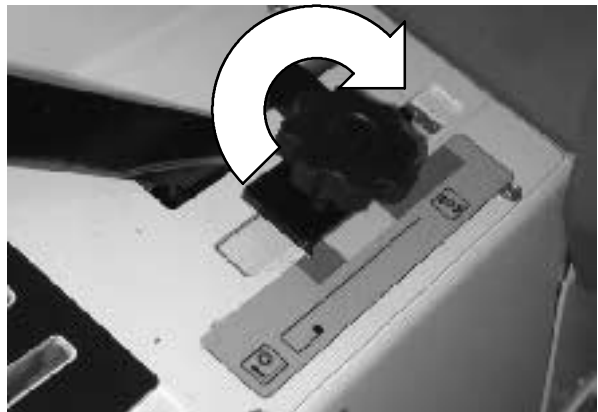

TURN SIGNAL SWITCH (OPTION)

The *turn signal switch* operates the turn signals.

Right: Push the switch lever forward.

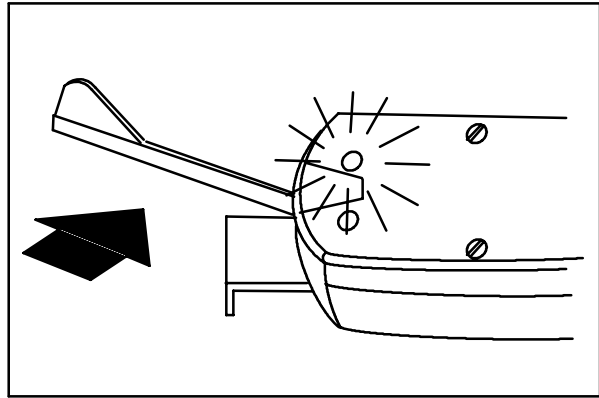

06487

Left: Pull the switch lever back.

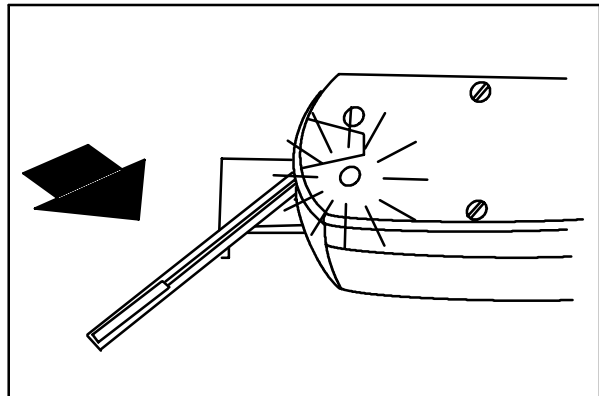

06488

Flashers: Pull out the knob.

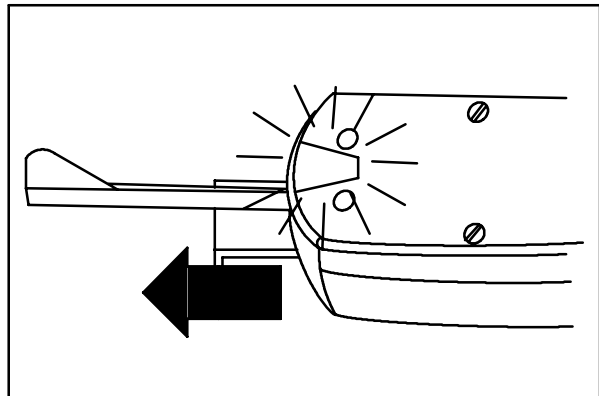

06745

OPERATION

HOPPER TEMPERATURE LIGHT - THERMO SENTRY

The *hopper temperature light* comes on when there is too much heat in the hopper, possibly from a fire. The Thermo Sentry will stop the vacuum fan.

The Thermo Sentry has to be reset manually, see *THERMO SENTRY* in *MAINTENANCE*.

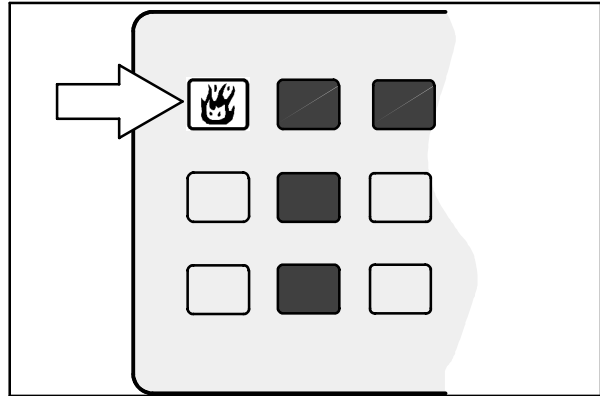

CHARGING SYSTEM LIGHT

The *charging system light* comes on when the existing voltage potential of the battery is not within normal range - 10 to 14 Volts. Stop operating the machine. Locate the problem and have it corrected.

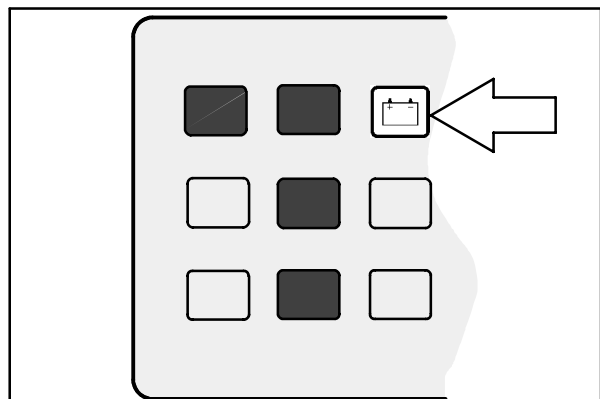

HOPPER DOOR LIGHT

The *hopper door light* comes on when the hopper door is closed. Make sure the hopper door is open and the *hopper door light* is off, before sweeping with the machine.

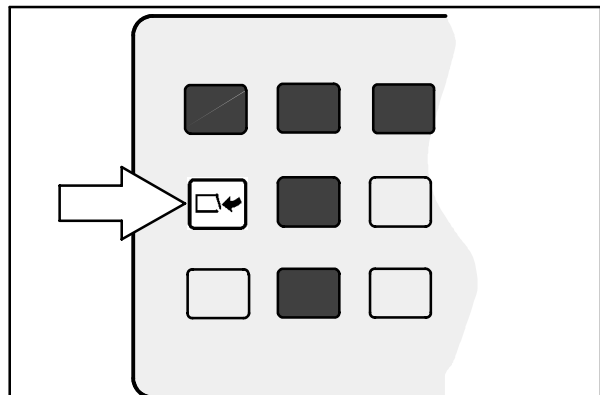

ENGINE OIL PRESSURE LIGHT

On machines serial number 024999 and below, the *engine oil pressure light* comes on when the engine oil pressure falls below 35 kPa (5 psi). Stop operating the machine. Locate the problem and have it corrected.

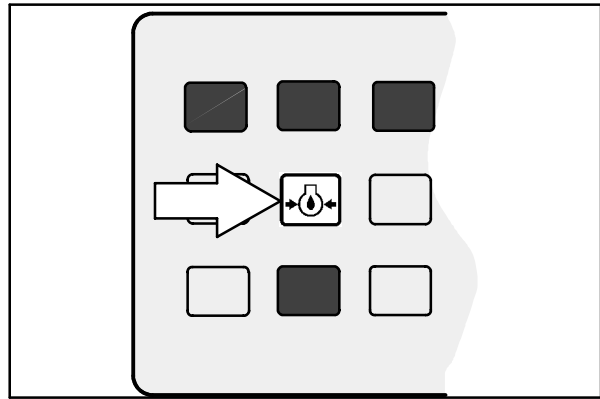
**LPG FUEL LIGHT**

The *LPG fuel light* comes on when the LPG fuel tank is almost empty. Stop sweeping with the machine, and return the machine to the service area. Replace the empty LPG fuel tank with a full tank. See the *CHANGING THE LPG TANK* section of the manual.

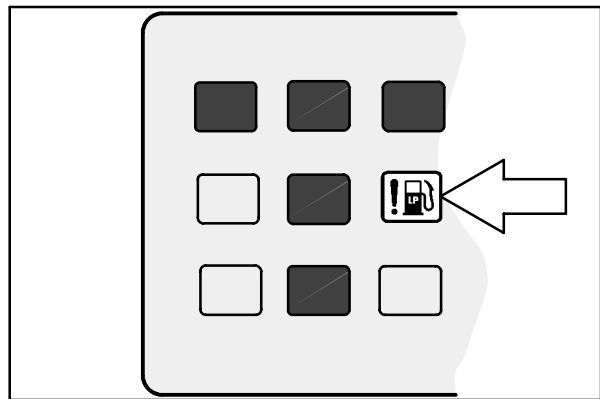

OPERATION

CLOGGED FILTER LIGHT

The *clogged filter light* comes on when the hopper dust filter is clogged.

To clean the filter, press the filter shaker switch. If the *clogged filter light* remains lit, manually clean the hopper dust filter. See *HOPPER DUST FILTER* in *MAINTENANCE*.

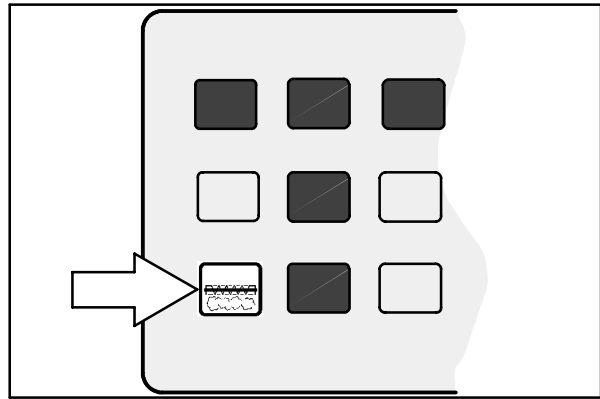

CHECK ENGINE LIGHT

The *check engine light* comes on if the engine control system detects a fault during machine operation and when the engine oil pressure falls below 35 kPa (5psi).

If the *check engine light* comes on while operating the machine, contact a TENNANT service representative to enter the CHECK ENGINE FAULT MODE, and determine the fault.

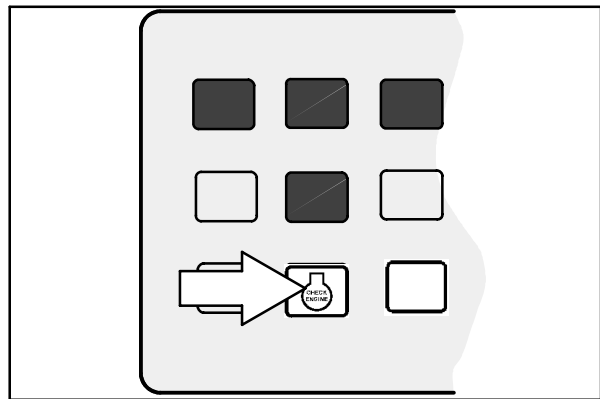

HIGH ENGINE TEMPERATURE LIGHT (for machines serial number 025000 and above)

The *high engine temperature light* comes on when the temperature of the engine coolant is more than 107° C (225° F). If the light comes on, stop operating machine. Locate the problem and have it corrected.

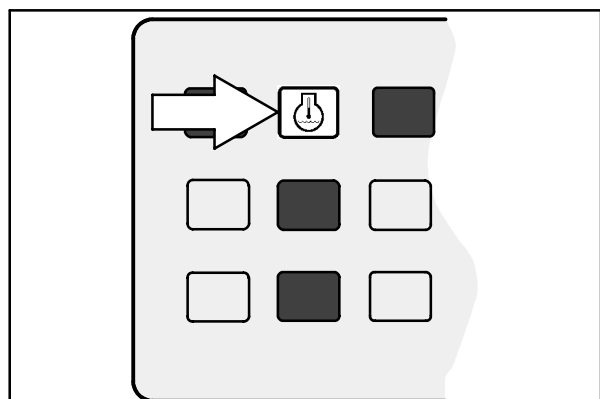

HOURMETER

The *hourmeter* records the number of hours the machine has been operated. Use this information to determine machine maintenance intervals.



FUEL LEVEL GAUGE

Gasoline powered machine: The *fuel level gauge* is an analog gauge that indicates how much fuel is in the fuel tank.

NOTE: Do not use leaded fuels. The use of leaded fuels will cause permanent damage to the system's oxygen sensor and catalytic converter.



LPG powered machine: The *fuel level gauge* on the LPG tank indicates how much fuel is in the LPG tank.

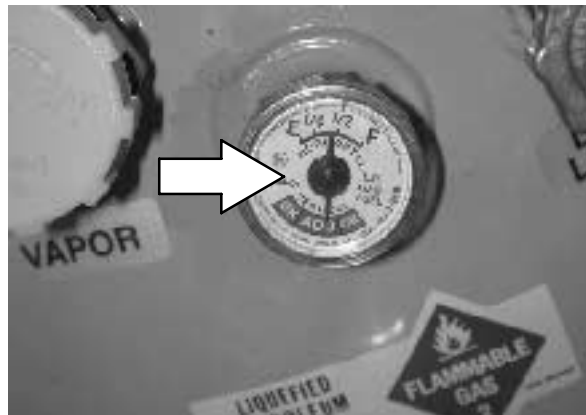

OPERATION

OPERATING/HAZARD LIGHTS SWITCH

The *operating/hazard light switch* powers on and off the operating/hazard lights.

Operating Lights On: Press the top of the switch.

Operating/Hazard Lights On: Press the bottom of the switch.

Off: Press the switch to the middle off position.

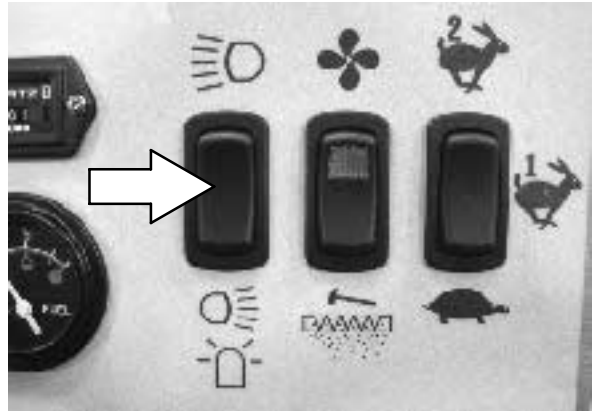

VACUUM FAN/FILTER SHAKER SWITCH

The *vacuum fan/filter shaker switch* starts and stops the vacuum fan and the hopper dust filter shaker.

Start Vacuum Fan: Press the top of the switch. The light in the top half of the switch will turn on.

Stop Vacuum Fan: Press the switch to the middle off position.

Start Filter Shaker: Press the bottom of the switch. The shaker will operate for approximately 10 seconds.

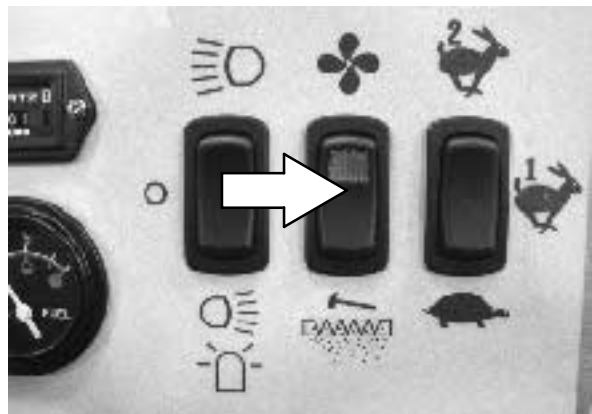

ENGINE SPEED SWITCH

The *engine speed switch* controls engine governed speed. The engine has three speeds; Idle, medium and high.

Idle: The engine will automatically start in idle speed. To return the engine to idle from another engine speed, press the bottom of the *engine speed switch*.

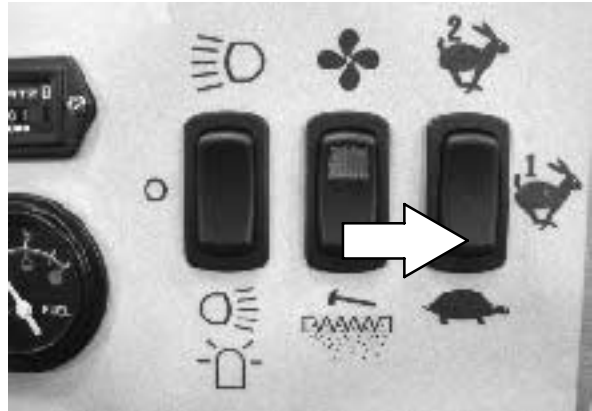

Medium (Fast 1): Press the *engine speed switch* to the middle position. This speed is for general sweeping.

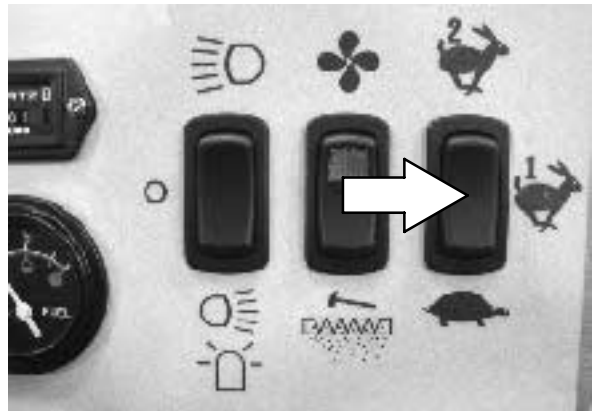

High (Fast 2): Press the top of the *engine speed switch*. This speed is for sweeping light litter.

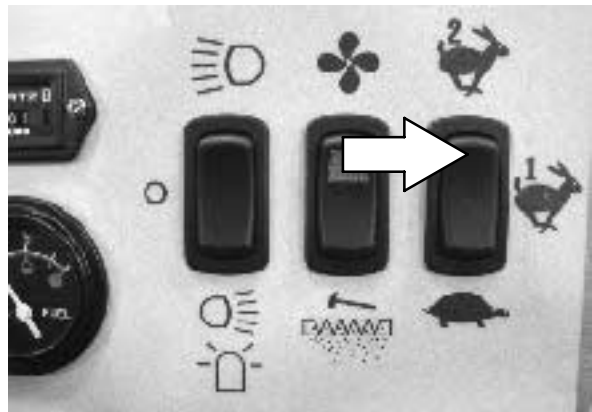

OPERATION

STEERING WHEEL

The *steering wheel* controls the machine's direction. The machine is very responsive to the steering wheel movements.

Left: Turn the *steering wheel* to the left.

Right: Turn the *steering wheel* to the right.

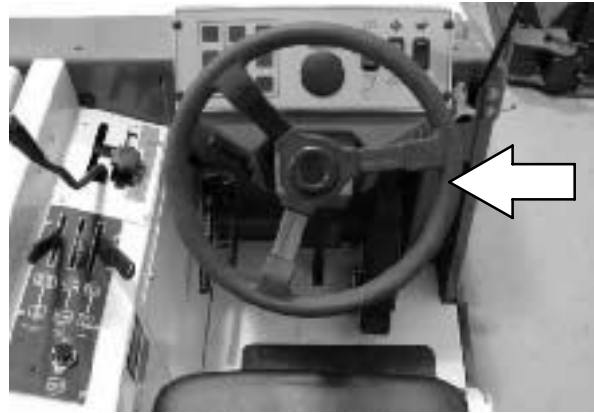

STEERING COLUMN TILT LEVER (OPTION)

The *steering column tilt lever* controls the angle of the steering column.

Adjust: Pull down on the tilt lever, move the column up or down, and release the tilt lever.

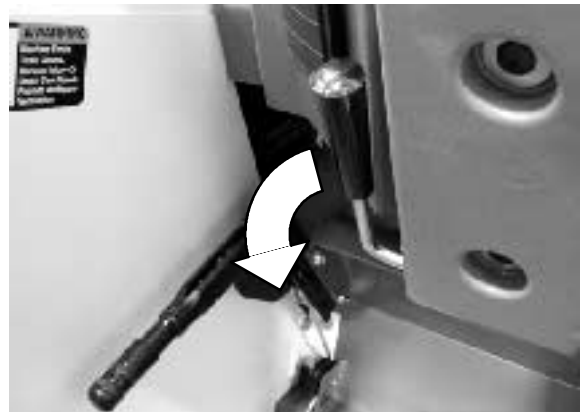

IGNITION SWITCH

The *ignition switch* starts and stops the engine with a key.

FOR SAFETY: When starting machine, keep foot on brake and directional pedal in neutral.

Start: Turn the key all the way clockwise.
Release the key as soon as the engine starts.

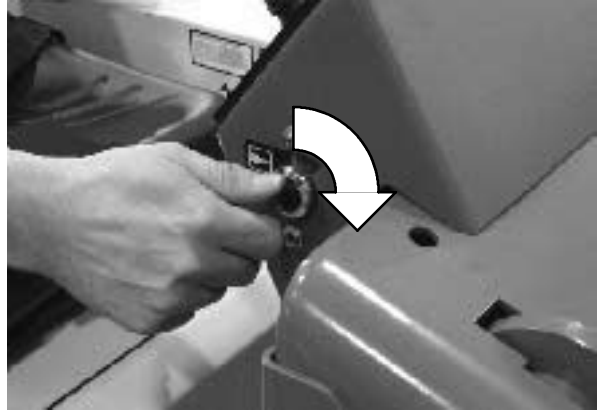

Stop: Turn the key counter-clockwise.

CAUTION: LPG engine will run for a few seconds after key is turned off. Apply parking brake before leaving machine.

NOTE: To protect the engine's emission components on LPG powered machines serial number 025000 and above, the engine will continue to operate for a few seconds after the ignition switch is turned off.



OPERATION

SIDE BRUSH POSITION LEVER

The *side brush position lever* lowers and raises the side brush.

Side Brush Down: Pull the *side brush position lever* down and to the right. Release the lever up into the **Brush Down** slot.



Side Brush Up: Pull the *side brush position lever* down and to the left. Release the lever up into the **Brush Up** slot.



SIDE BRUSH DOWN PRESSURE KNOB

The *side brush down pressure knob* changes the side brush contact with the sweeping surface.

Heavy: Turn the *side brush down pressure knob* counter-clockwise.



Light: Turn the *side brush down pressure knob* clockwise.



OPERATION

FUSES

Fuses are a one-time protection device designed to stop the flow of current in the event of a circuit overload. Never substitute higher value *fuses* than specified.

Machine *fuses* are located on the left side of the operator compartment, under the steering column.

The chart lists the *fuses* and the electrical components they protect.

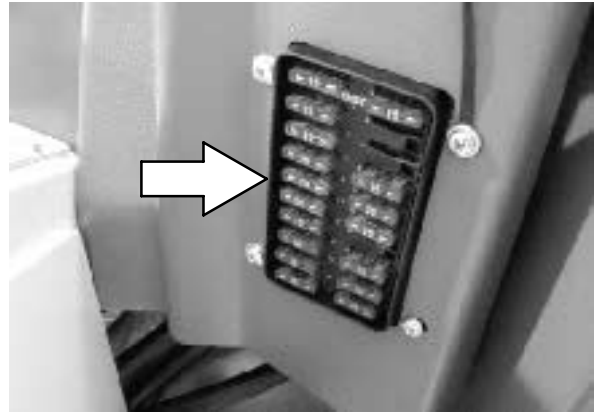

Fuses	Rating	Circuit Protected
F-1		Open
F-2		Open
F-3	15 A	Horn, Turn signals
F-4		Open
F-5	30 A	Key switch
F-6		Open
F-7	15 A	Cab options
F-8	15 A	Cab pressurizer (option)
F-9	15 A	Brake Lights
F-10		Open
F-11	15 A	Engine control, auxiliary relays
F-12	15 A	Reverse switch
F-13		Open
F-14		Open
F-15		Open
F-16		Open
F-17		Open
F-18		Open
F-19	15 A	Vacuum fan, filter shaker, indicator lights
F-20	15 A	Headlights, Warning lights

On machines serial number 025000 and above, there are *engine harness fuses* that are located near the engine inside the engine side door. Access the fuses by opening the engine side door.

Engine Harness Fuses		
Fuse	Rating	Circuit Protected
FU-1	5 A	Key switch
FU-2	20 A	Main power
FU-3	15 A	Auxiliary power
FU-4	15 A	Fuel pump

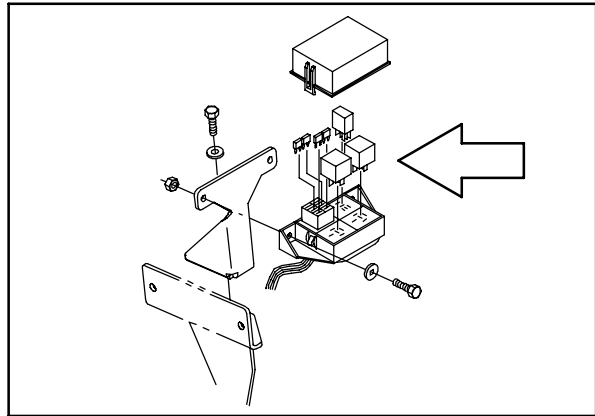

CIRCUIT BREAKERS (OPTION)

The circuit breakers are resettable electrical circuit protection devices. Their design stops the flow of current in the event of a circuit overload. Once a circuit breaker is tripped, it must be reset manually. Press the reset button after the breaker has cooled down.

If the overload that caused the circuit breaker to trip is still there, the circuit breaker will continue to stop current flow until the problem is corrected.

Both circuit breakers are located in the operator compartment, on the side instrument panel.

The chart lists the circuit breakers and the electrical components they protect.

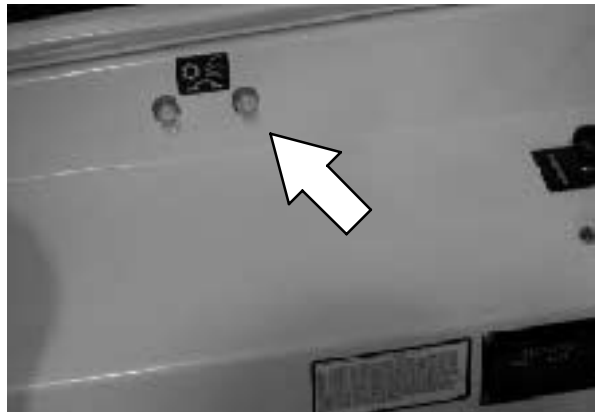

Circuit Breaker	Rating	Circuit Protected
CB-21	20 A	Air conditioner (option)
CB-22	20 A	Air conditioner (option)

OPERATION

LATCHES

The side doors, rear doors, engine cover, hopper cover, hydraulic tilt-out cooler, and cab door are secured with *latches*.

Open the right rear Grille Door: Pull the door open.

Open the left rear Grille Door: On machines serial number 024999 and below, push down on the door *latch*. On machines serial number 025000 and above, pull the door open.



Open the Main Brush Side Doors: Push down on the door *latch*.

Open the Cab Door: Pull up on the door handle.

Open the Engine Cover: Push in on the cover latch.

Close the Engine Cover: Pull on the release lever and lower the engine cover.

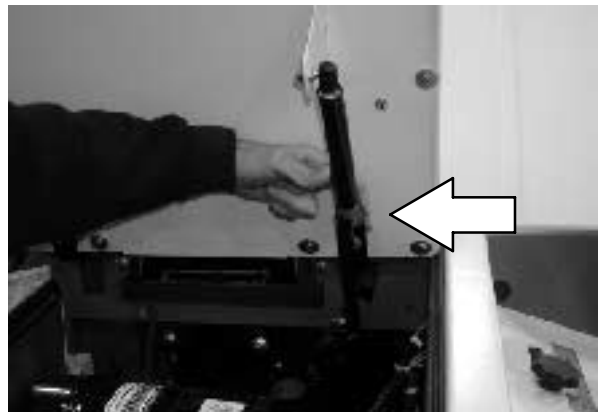

Open the Engine Side Door: Pull up on the door *latch*.

Open the Hopper Cover: Pull the rubber cover *latch* forward and pull up on the hopper cover.

Tilt out Hydraulic Cooler: On machines serial number 025000 and above, lift up on the rear of the latch and release the front of the latch from the catch.



HOPPER SUPPORT BAR

The *hopper support bar* is located on the operator's side of the hopper. The *hopper support bar* holds the hopper in the raised position to allow work under the hopper. DO NOT rely on the machine hydraulic system to keep the hopper raised.

 **WARNING: Raised hopper may fall. Engage hopper support bar.**

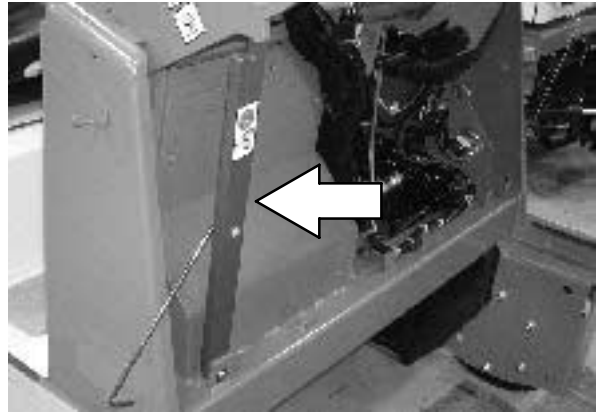

OPERATOR SEAT

The *operator seat* is a fixed back style with a forward-backward adjustment.

Adjust: Remove the seat mounting bolts, move the *operator seat* to the position desired, and reinstall and tighten the bolts.



Lift: Pull up on the *operator seat* mounting plate until the seat mount locks up.

Lower: Pull on the release lever and lower the seat mounting plate.



OPERATION

DELUXE SUSPENSION SEAT (OPTION)

The *deluxe suspension seat* has three adjustments. They are for backrest angle, operator weight adjustment and front to back adjustment.

The backrest angle adjustment lever adjusts the angle of the backrest.

Adjust: Raise the lever up and slide the seat backward or forward, until the backrest angle is in the desired position, and release the lever.



The front to back adjustment lever is located on the left hand side of the operator's seat.

Adjust: Pull the lever in, slide the seat forward or backwards to the desired position, and release the lever.

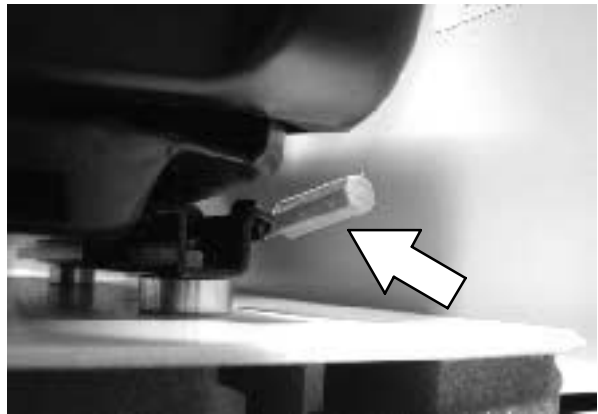

The weight adjustment lever controls the firmness of the operator's seat.



HEATER KNOB (OPTION)

The *heater knob* controls the cab heater on the cab option.

On: Pull the knob out until the air temperature is at the desired comfort level. For maximum heat, pull the knob out all the way.

Off: Push the knob in all the way.

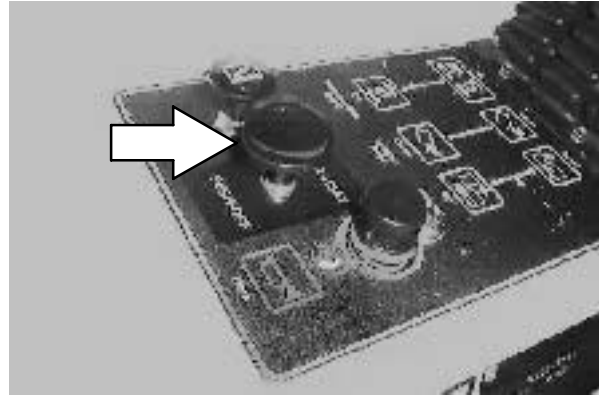
**AIR CONDITIONING SWITCH (OPTION)**

The *air conditioning switch* operates the cab's air conditioning in the optional cab.

On: Press the top of the switch.

Off: Press the bottom of the switch.

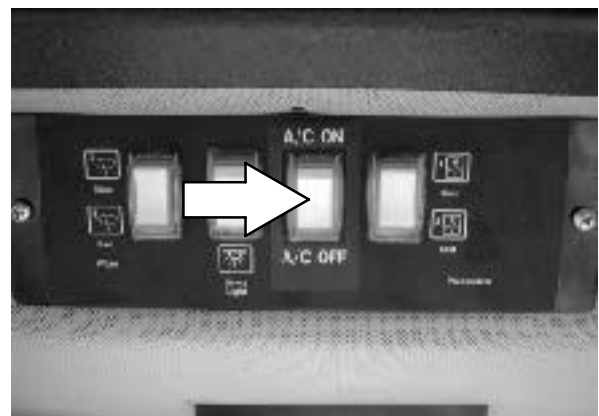
**WINDSHIELD WIPER SWITCH (OPTION)**

The *windshield wiper switch* operates the windshield wiper on the cab option. The wiper can be operated at two speeds.

Slow: Press the top of the switch.

Fast: Press the bottom of the switch.

Off: Return the switch to the middle position.

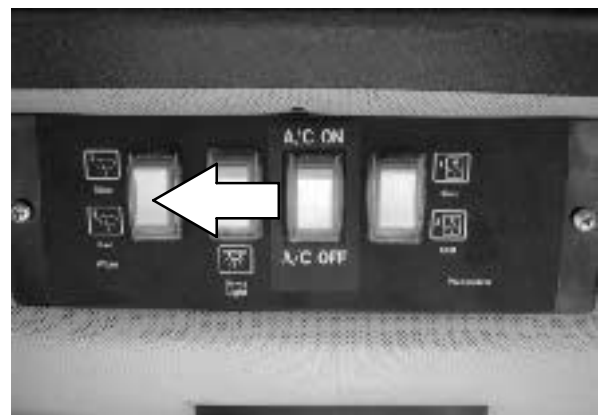

OPERATION

DOME LIGHT SWITCH (OPTION)

The *dome light switch* controls the dome light on the cab option.

On: Press the top of the switch.

Off: Press the bottom of the switch.

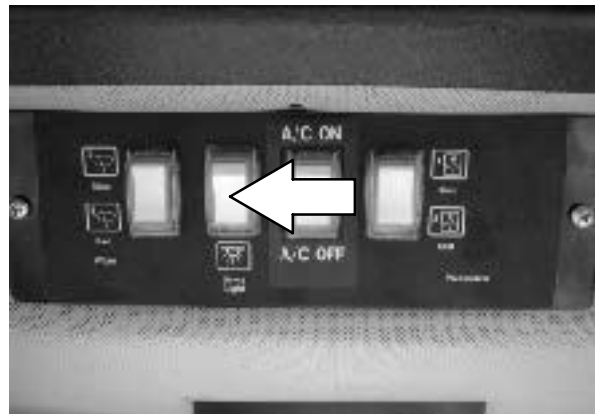

PRESSURIZER SWITCH (OPTION)

The *pressurizer switch* operates the cab pressurizer on the cab option. The pressurizer can be operated at two speeds.

Slow: Press the top of the switch.

Fast: Press the bottom of the switch.

Off: Return the switch to the middle position.



HOW THE MACHINE WORKS

The steering wheel controls the direction of machine travel. The directional pedal controls the speed and forward/reverse direction. The brake pedal slows and stops the machine.

The side brush sweeps debris into the path of the main brush. The main brush sweeps debris from the floor into the hopper. The vacuum system pulls dust and air through the hopper and the hopper dust filter.

When sweeping is finished, clean the hopper dust filter and empty the hopper.

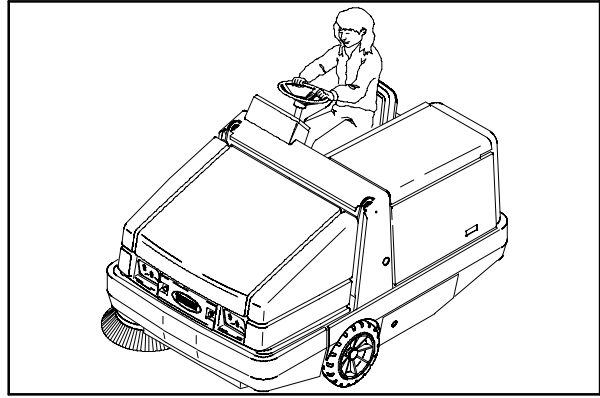

07816

PRE-OPERATION CHECKLIST

- Check the engine oil level.
- Check the engine coolant level.
- Check the radiator and hydraulic cooler fins for debris.
- Check the hydraulic fluid level
- Check the skirts and seals for damage and wear.
- Check the condition of the sweeping brushes. Remove any string, banding, plastic wrap, or other debris wrapped around them
- Check the sweeping brush patterns for adjustment.
- Check the condition of the hopper dust filter and seals. Clean as required.
- Check the brakes and steering for proper operation.
- Check the fuel level.
- Check the service records to determine if maintenance is needed.

OPERATION

CHANGING AN LPG FUEL TANK

1. Park the machine in a designated safe area.
2. Close the tank service valve.
3. Operate the engine until it stops from lack of fuel, then set the machine parking brake.

FOR SAFETY: When servicing machine, keep flames and sparks away from fuel system service area. Keep area well ventilated.

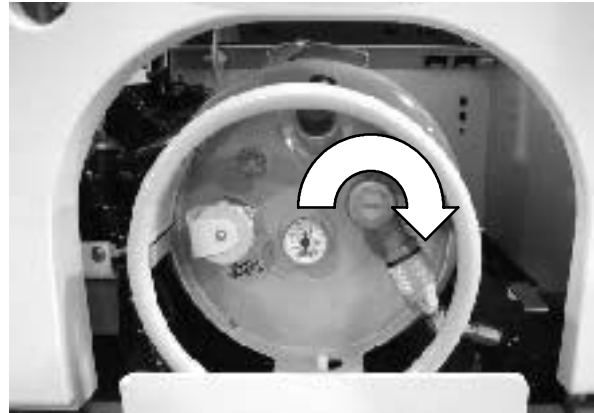

4. Put on gloves and remove the quick-disconnect tank coupling.
5. Unlatch and remove the empty LPG fuel tank from the machine and store the tank in a designated, safe area.

NOTE: Make sure the LPG fuel tank matches the fuel system (liquid tank with liquid system).

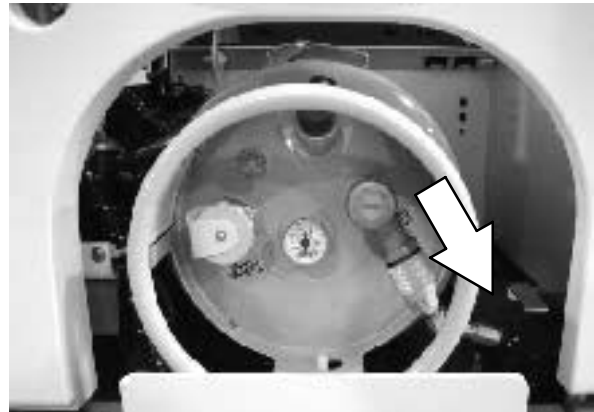

6. Carefully put the filled LPG tank in the machine so that the tank centering pin enters the aligning hole in the tank collar.

NOTE: If you cannot line up the centering pin, make sure you have the correct LPG fuel tank and then adjust the pin locator in or out.

7. Fasten the tank hold-down clamp to lock the tank in position.

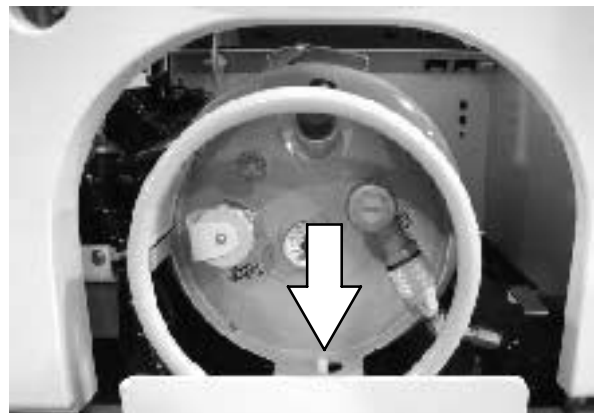

8. Connect the LPG fuel line to the tank service coupling. Make sure the service coupling is clean and free of damage. Also make sure it matches the machine service coupling.

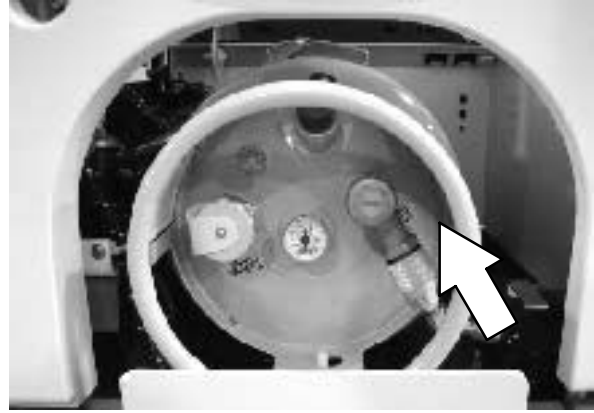

9. Open the tank service valve slowly and check for leaks. Close the service valve immediately if an LPG leak is found, and tell the appropriate personnel.

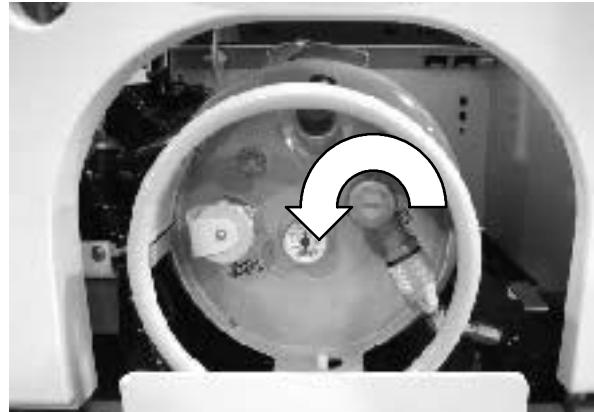

STARTING THE MACHINE

1. LPG powered machines: Open the liquid service valve slowly.

NOTE: Opening the service valve too quickly may cause the service check valve to stop the flow of LPG fuel. If the check valve stops the fuel flow, close the service valve, wait a few seconds and open the valve slowly again.

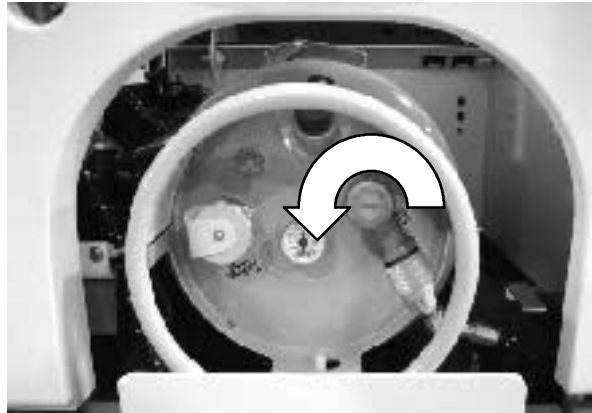

2. You must be in the operator's seat with the directional pedal in neutral, and your foot on the brake pedal or with the parking brake set.

FOR SAFETY: When starting machine, keep foot on brake and directional pedal in neutral.



3. Turn the ignition switch key clockwise until the engine starts.

NOTE: Do not operate the starter motor for more than 10 seconds at a time or after the engine has started. Allow the starter to cool between starting attempts or damage to the starter motor may occur.

4. Allow the engine and hydraulic system to warm up three to five minutes.

⚠ WARNING: Engine emits toxic gases. Severe respiratory damage or asphyxiation can result. Provide adequate ventilation. Consult with your regulatory authorities for exposure limits. Keep engine properly tuned.

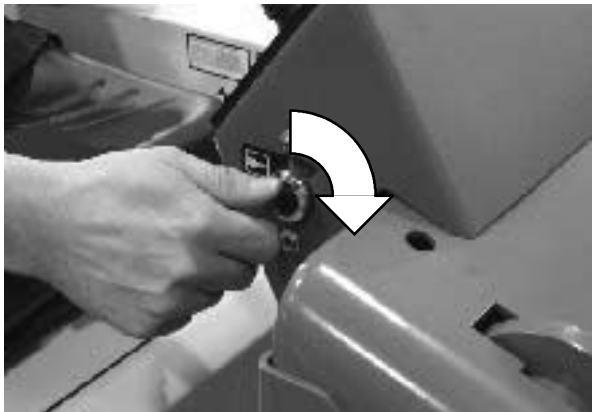

5. Release the machine parking brake.



6. Select the (Fast 1) engine speed with the engine speed switch.

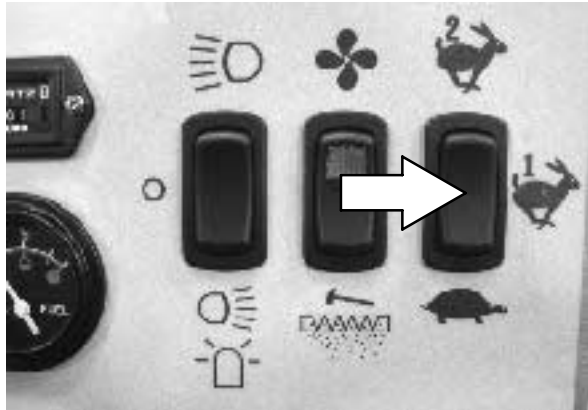

7. Drive the machine to the area being swept.

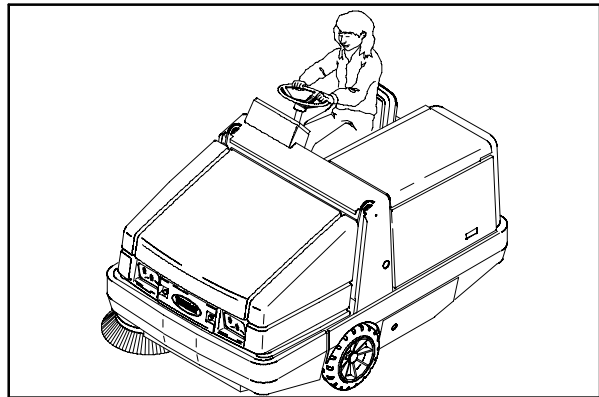

07816

SWEEPING AND BRUSH INFORMATION

Pick up oversized debris before sweeping. Flatten or remove bulky cartons from aisles before sweeping. Pick up pieces of wire, twine, string, etc., which could become entangled in brush or brush plugs.

Plan the sweeping in advance. Try to arrange long runs with minimum stopping and starting. Sweep debris from very narrow aisles into main aisles ahead of time. Do an entire floor or section at one time. Sweep as straight a path as possible. Avoid bumping into posts or scraping the sides of the sweeper. Overlap the brush paths.

Avoid turning the steering wheel too sharply when the machine is in motion. The machine is very responsive to the movement of the steering wheel. Avoid sudden turns, except in emergencies.

Speed up the engine to (Fast 2) when picking up light litter. This will improve both litter pickup and hopper loading. Do not use the (Fast 2) speed in dusty environments. The machine can dust and clog the hopper dust filter. Operate the engine in the (Fast 1) position when picking up general debris.

For best results, use the correct brush type for your sweeping application. The following are recommendations for main and side brush applications.

Nylon 8-double Row Main Brush -

Recommended for general sweeping, and has good hopper loading. Nylon has the longest life of the bristle types. Use this brush for sweeping rough or irregular surfaces.

Polypropylene and Wire 8-double Row Main Brush - The wire bristles loosen slightly packed soilage and heavier debris. The polypropylene bristles sweep up the debris with excellent hopper loading.

Crinkle Wire 8-double Row Main Brush - The stiff wire bristles cut through compacted grime, hard to sweep dirt, and dirt mixed with oil, grease, or mud. This brush is recommended for foundry sweeping where heat may melt synthetic bristles. This brush has good hopper loading ability, but is not recommended for dusty applications.

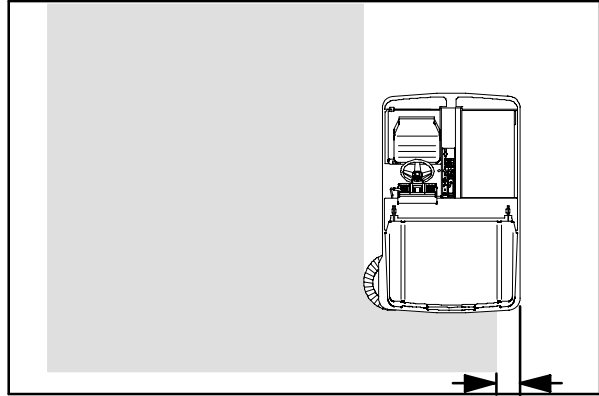

07817

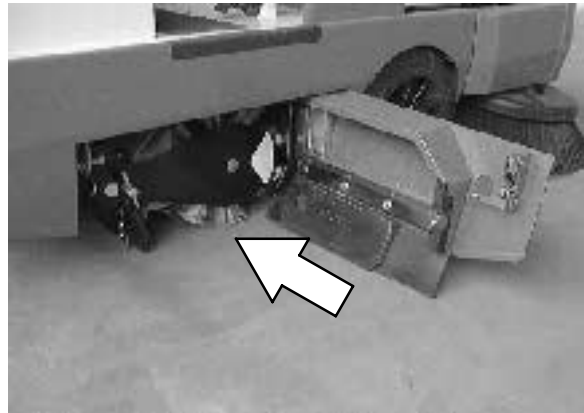

Nylon 24-row Main Brush - Recommended for severe dust conditions on rough surfaces. This brush has excellent pickup and long life.

Fiber and Wire 24-row Main Brush - Offers good sweeping action and pickup in heavy dust concentrations. This brush is recommended where soilage is slightly encrusted. The brush is not recommended for heavy buildup or hard packed soilage.

Polypropylene Side Brush - A good general purpose brush for sweeping of light to medium debris in both indoor and outdoor applications. This brush is recommended when bristles may get wet.

Nylon Side Brush - A longer life, general purpose brush that is recommended for rough surfaces.

Flat Wire Side Brush - Recommended for outside and curb-side sweeping where soilage is heavy or compacted. The stiff wire bristles dig out soilage. This brush is also recommended for foundry sweeping where heat may melt synthetic bristles.



SWEEPING

1. Select an engine speed.

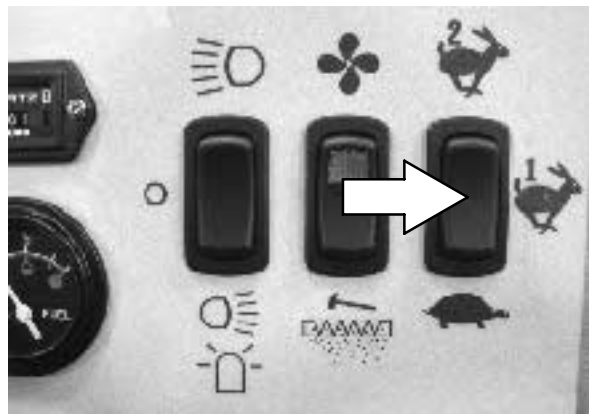

2. Make sure the hopper door light is off. If the hopper door light is on, open the hopper door.

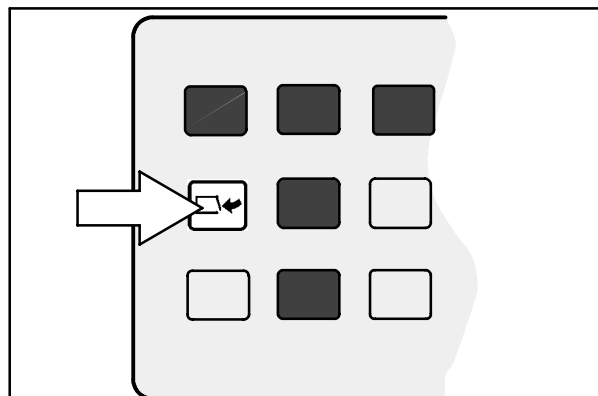

OPERATION

3. Push the main brush and side brush lever into the **On** position, or pull the lever into the **On** position.

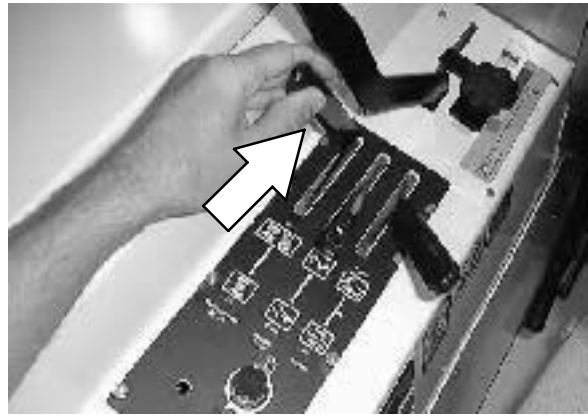

4. Press the vacuum fan switch to start the vacuum.

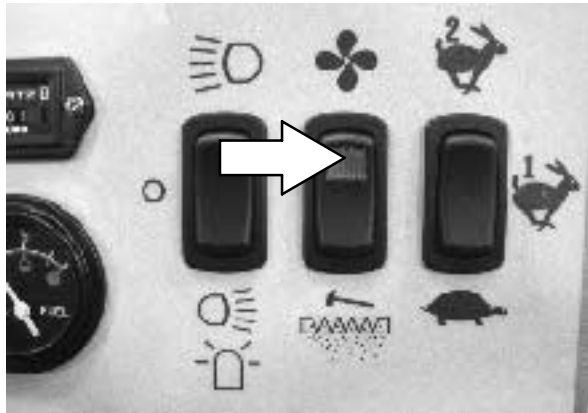

5. Pull the main brush position lever back and to the left. Release the lever forward into the **Down** position.

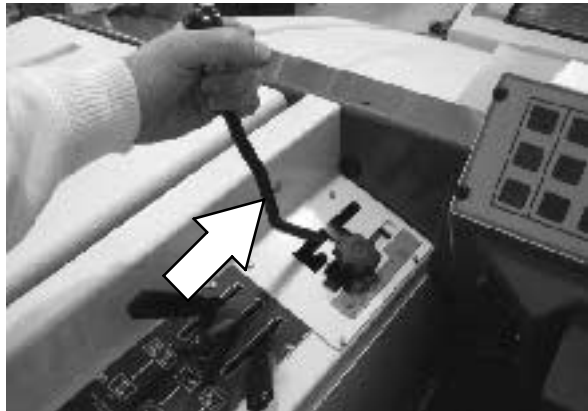

6. Pull the side brush position lever back and to the right. Release the lever up into the **Down** slot.

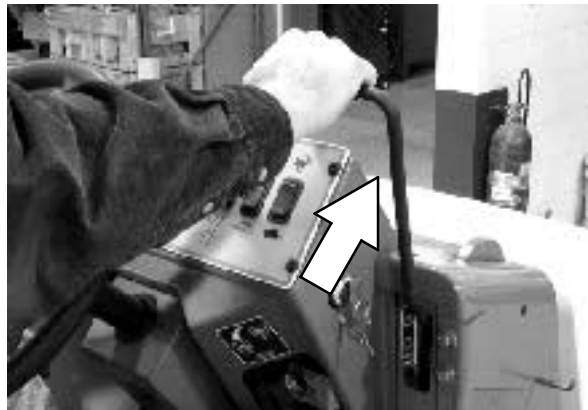

7. Sweep as needed.

STOP SWEEPING

1. Pull the main brush position lever all the way back and to the right. Release the lever forward into the **Up** position.

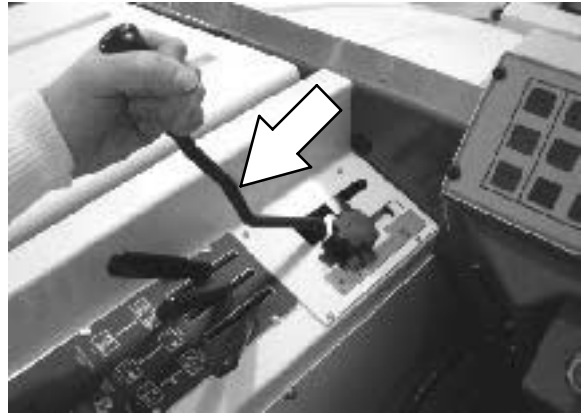

2. Pull the side brush position lever down and to the left. Release the lever up into the **Up** slot.



3. Pull the main brush and side brush lever into the middle (Off) position.



OPERATION

4. Pull the hopper door lever into the **Close** position until the hopper door light comes on.



5. Press the filter shaker switch to activate the hopper filter shaker.

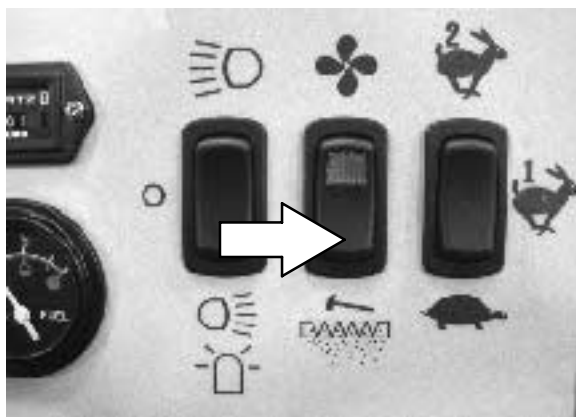

EMPTYING THE HOPPER

1. Slowly drive the machine to the debris site or debris container.

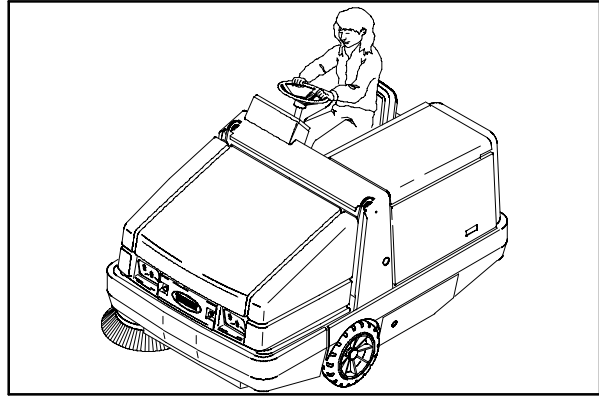

07816

2. Pull the hopper door lever into the **Close** position until the hopper door light comes on.



3. Release the hopper door lever into the middle (Hold) position.



OPERATION

4. Pull the hopper lift lever into the **Up** position and raise the hopper to the desired height.

FOR SAFETY: When using machine, make sure adequate clearance is available before raising hopper.

NOTE: Be aware that the minimum ceiling height needed to high dump the hopper is 2745 mm (9 ft.).

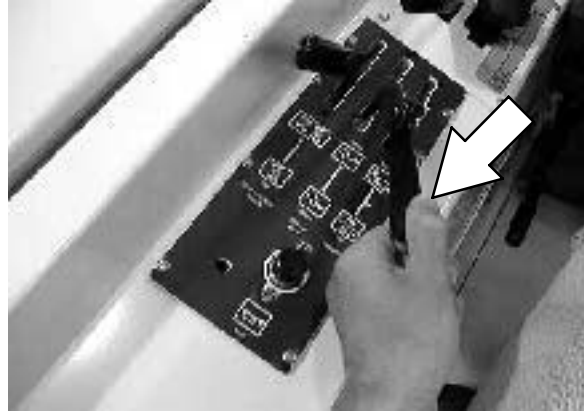

5. Release the hopper lift lever up and into the middle (Hold) position.

FOR SAFETY: When using machine, move machine with care when hopper is raised.

6. Drive the machine up to the debris container.
7. Lower the hopper into the debris container to control dust.

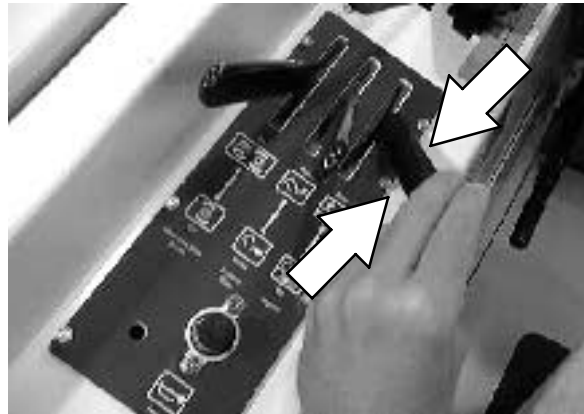

8. Push the hopper door lever into the **Open** position and leave it there.

9. Raise the hopper enough and/or close the hopper door to clear the top of the debris container.



10. Slowly back the machine away from the debris site or debris container.

For Safety: When using machine, use care when reversing machine.

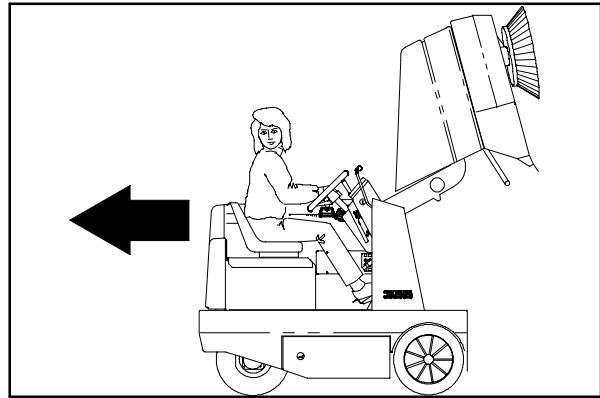

07996

11. Push the hopper lift lever into the **Down** position.



OPERATION

STOP THE MACHINE

1. Stop sweeping.
2. Take your foot off the directional pedal. Step on the brake pedal.



3. Select the (Idle) position with the engine speed switch.

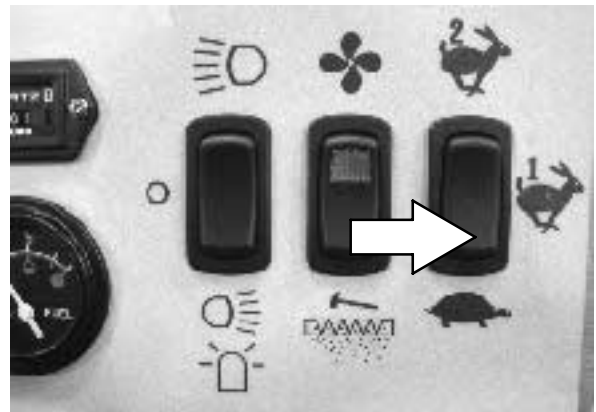

4. Set the machine parking brake.

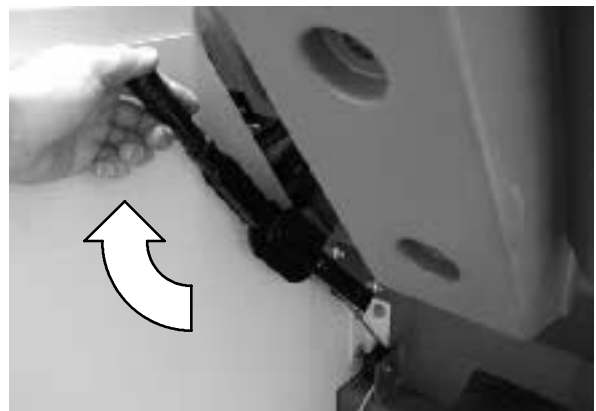

- Turn the ignition switch key counter-clockwise to stop the engine. Remove the switch key.

FOR SAFETY: Before leaving or servicing machine; stop on level surface, set parking brake, turn off machine and remove key.



CAUTION: LPG engine will run for a few seconds after key is turned off. Apply parking brake before leaving machine.

NOTE: To protect the engine's emission components on LPG powered machines serial number 025000 and above, the engine will continue to operate for a few seconds after the ignition switch is turned off.



- LPG powered machines: Close the LPG tank's liquid service valve.

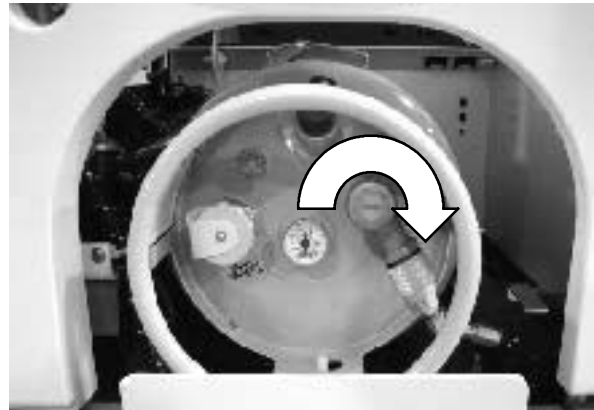

POST-OPERATION CHECKLIST

- Check the engine oil level.
- Check the engine coolant level.
- Check the radiator and hydraulic cooler fins for debris.
- Check the hydraulic fluid level
- Check the air filter indicator.
- Check the skirts and seals for damage and wear.
- Check the condition of the sweeping brushes. Remove any string, banding, plastic wrap, or other debris wrapped around them
- Check the sweeping brush patterns for adjustment.
- Check the brakes and steering for proper operation.
- Check the fuel level
- Check the service records to determine maintenance requirements.

ENGAGING HOPPER SUPPORT BAR

1. Set the machine parking brake.

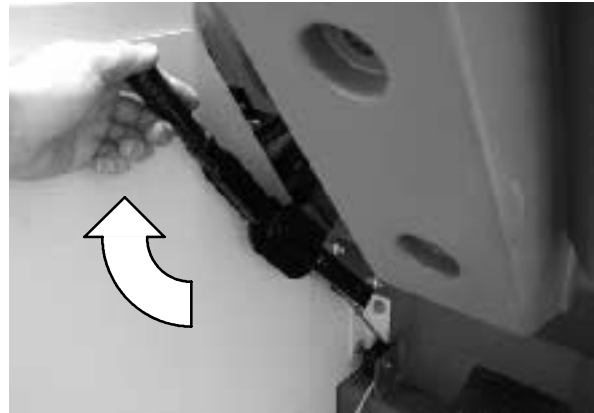

2. Start the engine.

For Safety: When starting machine, keep foot on brake and directional pedal in neutral.

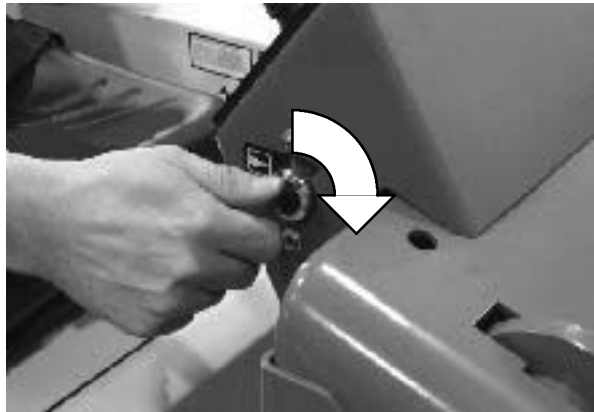

3. Raise the hopper all the way up.

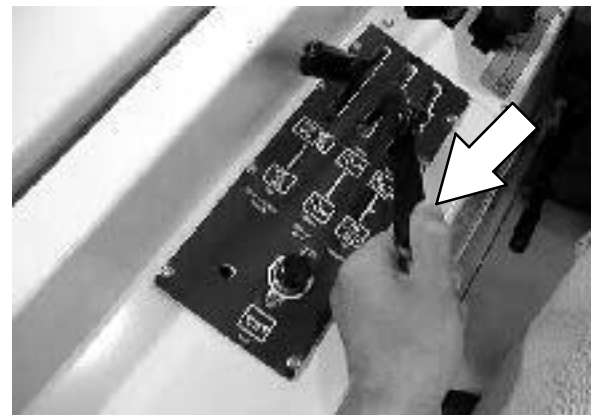

OPERATION

4. Lift and position the hopper support bar under the hopper lift arm.

 **WARNING: Raised hopper may fall. Engage hopper support bar.**



5. Slowly lower the hopper so the lift arm rests on the support bar.

 **WARNING: Lift arm pinch point. Stay clear of hopper lift arms.**



6. Shut the engine off.



DISENGAGING HOPPER SUPPORT BAR

1. Start the engine.

FOR SAFETY: When starting machine, keep foot on brake and directional pedal in neutral.

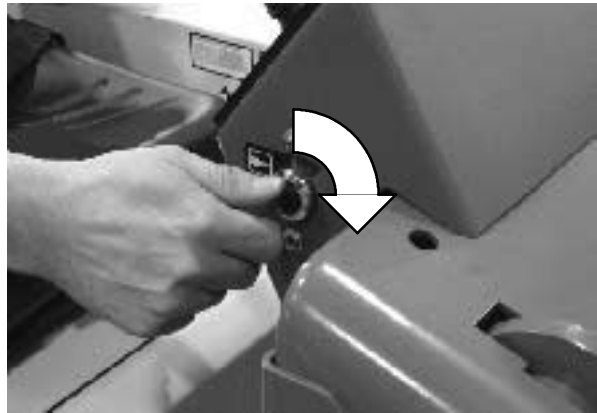

2. Raise the hopper slightly to release the hopper support bar.

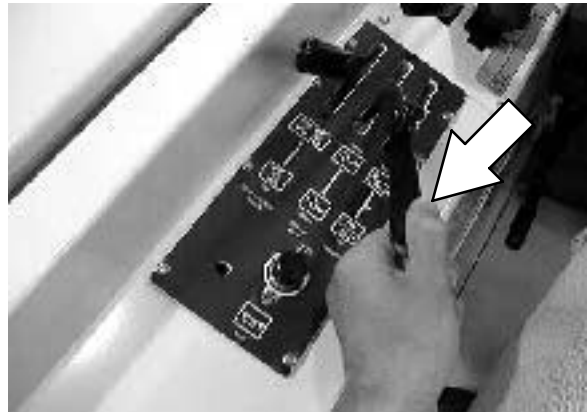

3. Put the support bar in its storage position.

 **WARNING: Lift arm pinch point. Stay clear of hopper lift arms.**



OPERATION

4. Lower the hopper.



5. Shut the engine off.



OPERATION ON INCLINES

Drive the machine slowly on inclines. Use the brake pedal to control machine speed on descending inclines.

The maximum rated incline is 6°.

FOR SAFETY: When using machine, go slow on inclines and slippery surfaces.

OPTIONS

VACUUM WAND

The vacuum wand uses the machine's vacuum system. The vacuum hose and wand allow the operator to pick-up debris that is out of reach of the machine's sweeping path.

The vacuum wand can be used from the operator's seat while the machine is stopped. Do not operate the vacuum wand while driving the machine.

⚠ WARNING: Accident may occur. Do not operate vacuum or blower wand while driving.

1. Stop the machine within reach of the area to be vacuumed.
2. Shut the engine off.
3. Set the machine parking brake.

FOR SAFETY: Before leaving or servicing machine; stop on level surface, set parking brake, turn off machine and remove key.

4. Release the rubber strap(s) from the top edge of the vacuum hose.
5. On machines without a cab, lift the hose handle off the support hook and remove the hose end from the support hook.

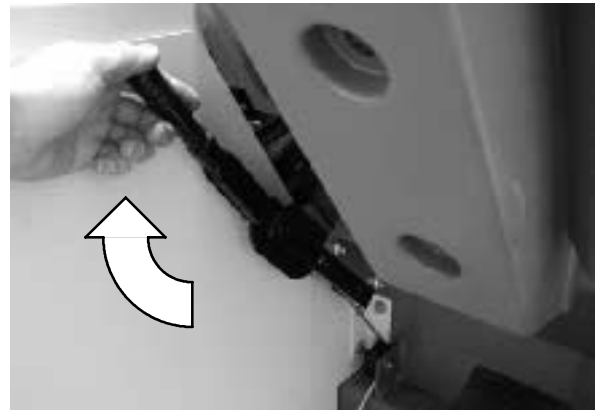

OPERATION

6. Open the vacuum wand door on the front of the machine hopper. Align the slot in the vacuum hose with the pin inside the vacuum door. Install the end of the vacuum hose in the machine.

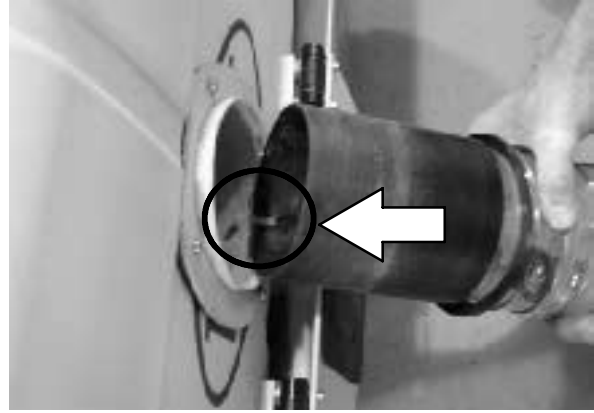

7. On machines without a cab, disconnect the rubber straps securing the solid section of vacuum hose to the machine.

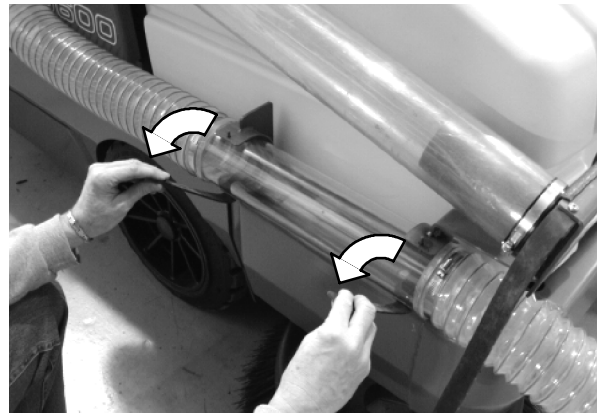

On machines with a cab, disconnect the rubber straps securing the vacuum hose handle to the machine.

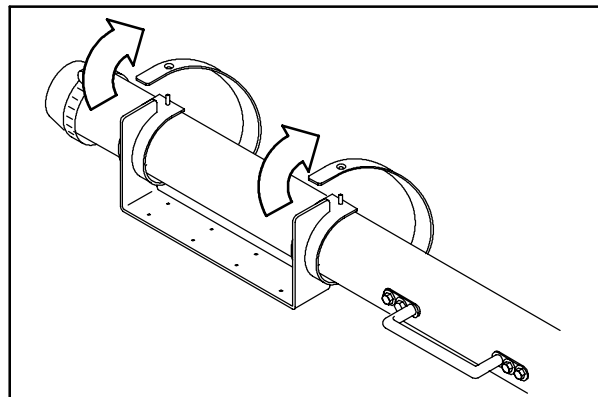

8. Start the engine.

FOR SAFETY: When starting machine, keep foot on brake and directional pedal in neutral.

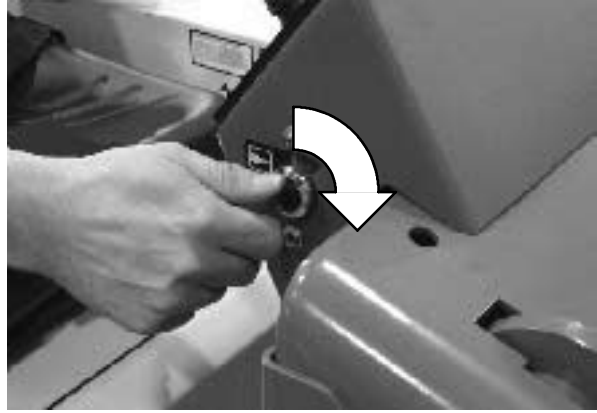

9. Select the (Fast 2) engine speed with the engine speed switch.

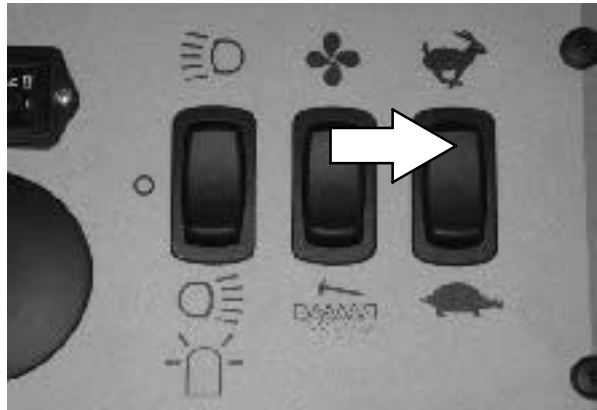

10. Pull and hold the hopper door lever into the **Close** position until the hopper door light comes on.



OPERATION

11. Press the vacuum fan switch to start the vacuum.

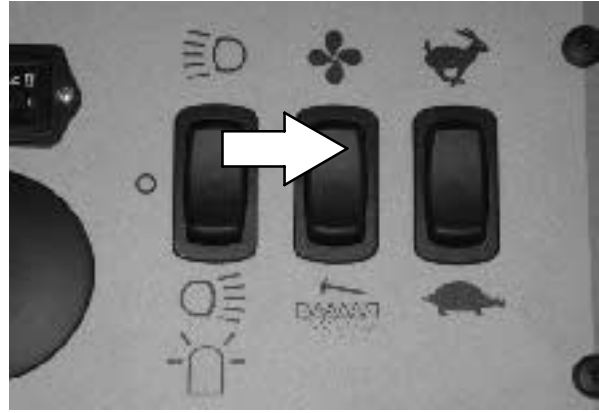

12. Vacuum the area as needed.



13. Press the vacuum switch to shut off the vacuum.



14. Shut the engine off.



15. Open the hopper cover.

16. Remove the vacuum hose from the hopper connection and close the vacuum wand door.

17. Secure the vacuum wand and hose in place with the mounting clips and rubber strap(s).

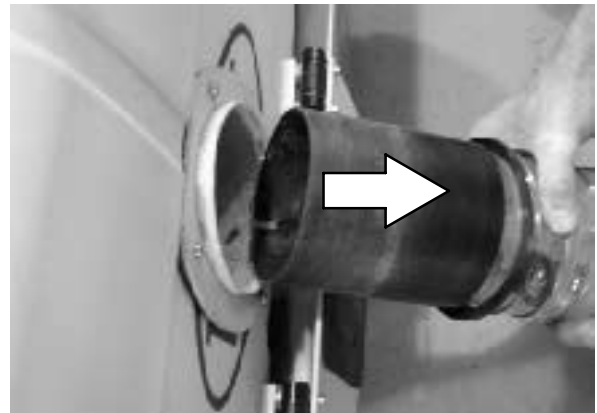

BLOWER WAND

The blower wand uses the machine's vacuum exhaust. The blower wand allows the operator to blow debris out from areas that are out of reach of the machine's sweeping path.

The blower wand can be used from the operator's seat while the machine is stopped. Do not operate the blower wand while driving the machine.

 **WARNING: Accident may occur. Do not operate vacuum or blower wand while driving.**

1. Remove the blower attachment from the back of the machine.

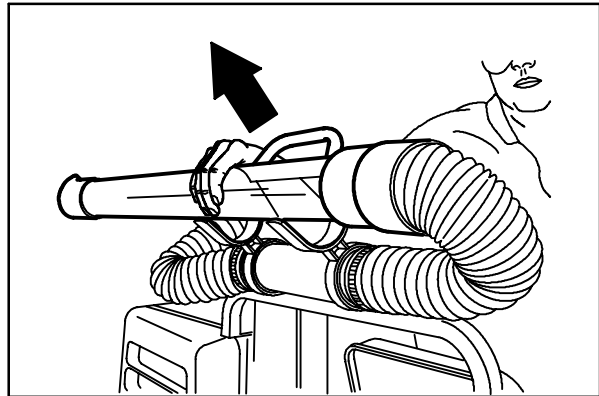

08142

2. Move the lever on the engine cover forward into the **ON** position to start airflow through the wand.

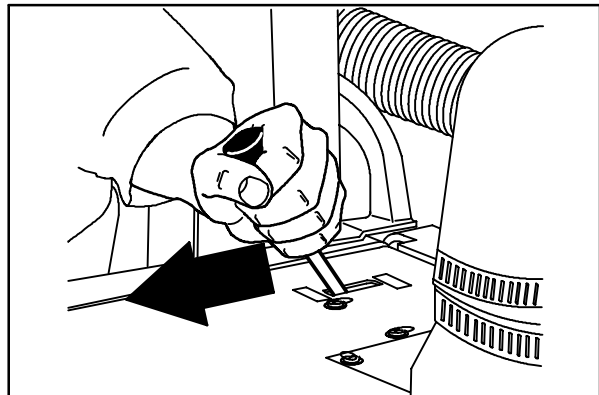

08144

3. Direct the wand into the area of debris.

The operator can rest the wand on the side bracket.

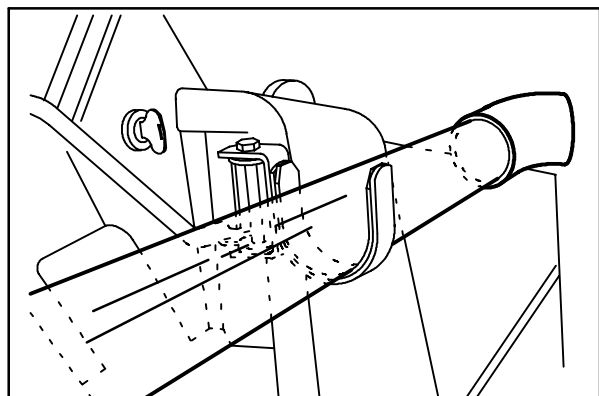

08147

4. Move the lever on the engine cover backward into the **OFF** position to stop airflow through the wand.

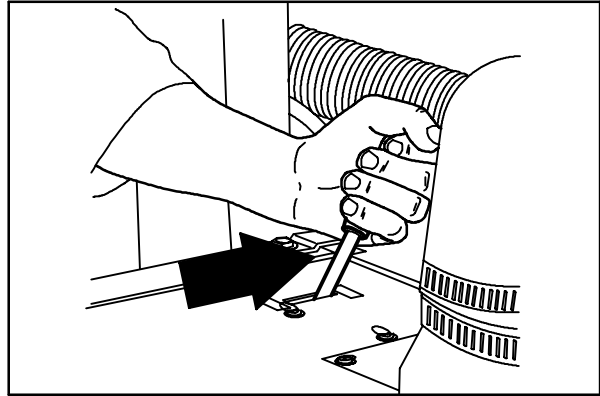

08145

5. Put the blower attachment on the back of the machine.

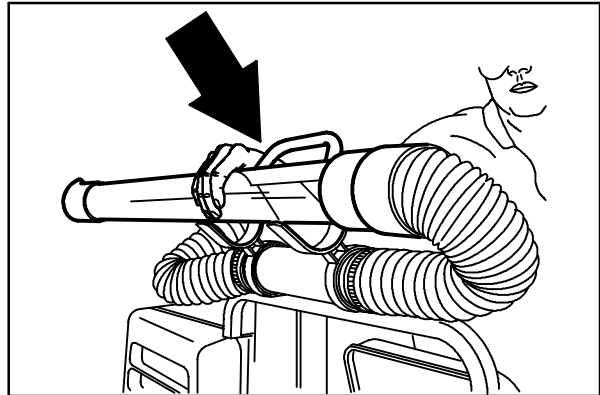

08145

HEATER VALVE

The *heater valve* is located in the engine compartment on the side of the engine. The valve controls the flow of hot coolant to the heater core.

The amount of coolant that flows through the *heater valve* is controlled with the *heater knob* in the cab (option).

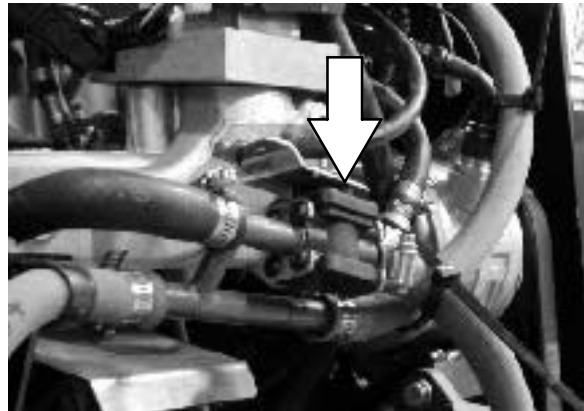

OPERATION

MACHINE TROUBLESHOOTING

Problem	Cause	Remedy
Excessive dusting	Brush skirts and dust seals worn, damaged, out of adjustment	Replace or adjust brush skirts or dust seals
	Hopper dust filter clogged	Shake and/or clean or replace dust filter
	Hopper dust filter not shaking clean	Connect shaker solenoid spring
		Install filter shaker plate correctly
		Insert shaker solenoid pin into the hole of filter element comb
	Engine operating at (Fast 2) speed	Operate engine at (Fast 1) speed
	Vacuum hose damaged	Replace vacuum hose
	Vacuum fan failure	Contact TENNANT service personnel
	Hopper door partially or completely closed	Open the hopper door
	Thermo Sentry™ tripped	Reset Thermo Sentry™
Poor sweeping performance	Brush bristles worn	Replace brushes
	Main and side brushes not adjusted properly	Adjust main and side brushes
	Debris caught in main brush drive mechanism	Free drive mechanism of debris
	Main brush drive failure	Contact TENNANT service personnel
	Side brush drive failure	Contact TENNANT service personnel
	Hopper full	Empty hopper
	Hopper lip skirts worn or damaged	Replace lip skirts
	Hopper door partially or completely closed	Open the hopper door
	Wrong sweeping brush	Contact TENNANT representative for recommendations
	Main brush in Down position	Put main brush in Float position

MAINTENANCE

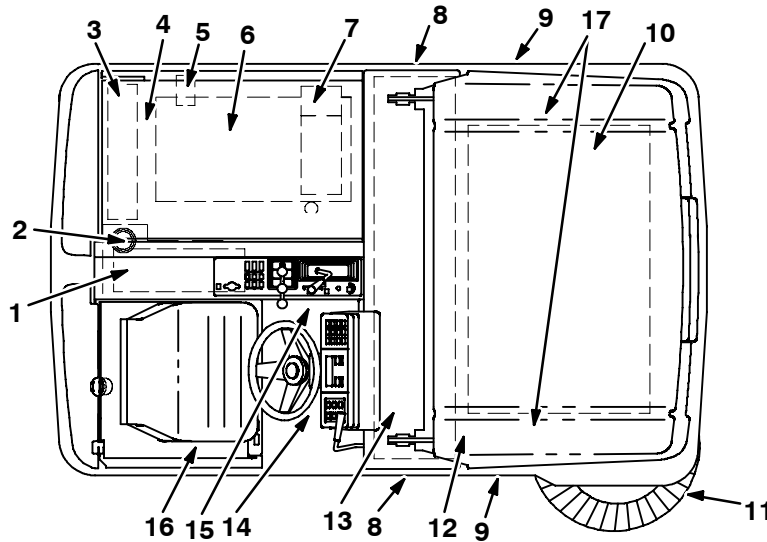

07747

MAINTENANCE CHART

NOTE: Check procedures indicted () after the first 50-hours of operation.*

Interval	Key	Description	Procedure	Lubricant/ Fluid	No. of Service Points
Daily	7	Engine air filter	Empty dust cap	-	1
	6	Engine	Check oil level	EO	1
			Check coolant level in reservoir	WG	1
	8	Brush compartment skirts	Check for damage, wear and adjustment	-	5
	12	Hopper lip skirts	Check for damage, wear and adjustment	-	3
	12	Hopper side skirt	Check for damage and wear	-	1
	13	Main brush	Check for damage, wear, and adjustment	-	1
			Check brush pattern	-	1
11	Side brush	Check for damage, wear, and adjustment	-	1	
		Check brush pattern	-	1	
50 Hours	13	Main brush	Rotate end-for-end	-	1
100 Hours	10	Hopper dust filter	Check for damage, clean or replace	-	1
	3	Radiator	Clean core exterior	-	1
			Check coolant level	WG	1
	2	Hydraulic fluid reservoir	Check fluid level	HYDO	1
	1	Rear tire	Check pressure	-	1
8	Main brush/hopper seals	Check for damage or wear	-	8	

Interval	Key	Description	Procedure	Lubricant/ Fluid	No. of Service Points
100 Hours	6	Engine	Change oil and filter element	EO	1
	6	Engine (030000-)	Drain oil from electronic pressure regulator	-	1
200 Hours	4	Engine fan belt	*Check tension	-	1
	3	Radiator hoses and clamps	Check for tightness and wear	-	2
	15	Parking brake	Check adjustment	-	1
	14	Brake pedal	Check and adjust travel	-	1
	1	Rear wheel support bearings	Lubricate	SPL	2
	17	Hopper bearings	Lubricate	SPL	2
	11	Side brush guard	Rotate 90°	-	1
400 Hours	9	Front wheel bearings	Check, lubricate, and adjust	SPL	2
	6	Engine (000000-024999)	Clean or replace and adjust spark plugs	-	4
			Replace air filter	-	1
			Replace oil fill/PCV breather cap	-	4
			Replace fuel filter (Gasoline)	-	4
	6	Engine (025000-)	Clean or replace and adjust spark plugs	-	4
			Clean PCV hoses	-	4
			Replace air filter	-	1
			Replace fuel filter element (LPG)	-	1
	800 Hours	3	Cooling system	Flush	WG
2		Hydraulic fluid reservoir	Replace hydraulic breather	-	1
6		Engine (025000-)	Replace fuel filter (Gasoline)	-	1
			Check timing belt	-	1
2		Hydraulic fluid reservoir	Replace suction strainer	-	1
			Change hydraulic fluid	HYDO	1
5		Hydraulic fluid filter	Change filter element	-	1
2		Hydraulic hoses	Check for wear and damage	-	31
1		Propelling motor	*Torque shaft nut	-	1
1		Rear wheel	*Torque wheel nuts	-	1
16	Battery	*Clean and tighten battery cable connections	-	1	
1000 Hours	6	Engine (000000-024999)	Replace timing belt	-	1
2000 Hours	6	Engine (025000-)	Replace timing belt	-	1

LUBRICANT/FLUID

EO . . . Engine oil, 10W30 SAE-SG/SH rated

HYDO . Tennant Company or approved hydraulic fluid

WG . . . Water and permanent-type ethylene glycol anti-freeze, -34° C (-30° F)

SPL . . . Special lubricant, Lubriplate EMB grease (TENNANT part no. 01433-1)

LUBRICATION

ENGINE

Check the engine oil level daily. Change the engine oil and oil filter every 100 hours of machine operation. Use only 10W30 SAE-SG/SH rated engine oil.

Fill the engine oil until the oil level is between the indicator marks on the dipstick. DO NOT fill past the top indicator mark. The engine oil capacity is 3.3L (3.7qt) including the oil filter.

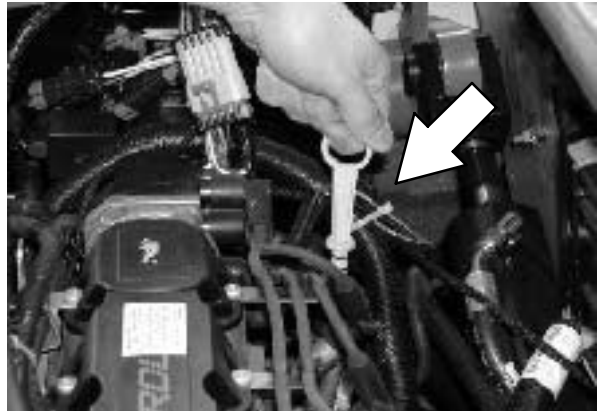

REAR WHEEL SUPPORT

The rear wheel support pivots the rear wheel. The support has two grease fittings for the bearings. The rear wheel support bearings must be lubricated every 200 hours of operation. Use Lubriplate EMB grease (TENNANT part no. 01433-1).

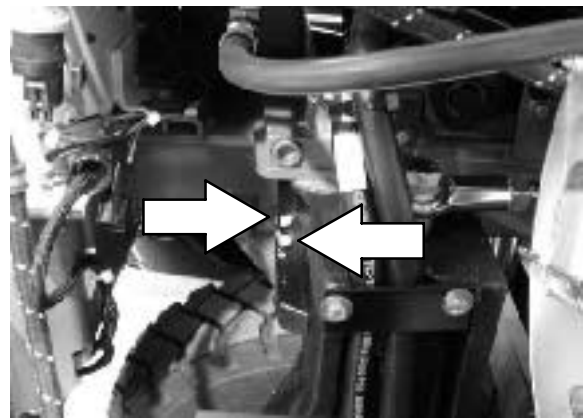

HOPPER BEARINGS

The hopper pivots on the hopper bearings whenever the hopper is raised or emptied. The hopper bearings must be lubricated after every 200 hours of operation. Use Lubriplate EMB grease (TENNANT part no. 01433-1).

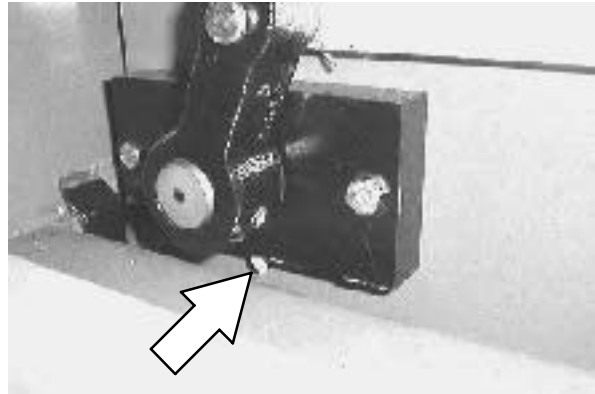
**FRONT WHEEL BEARINGS**

Inspect the front wheel bearings for seal damage, and repack and adjust every 400 hours of operation. Use Lubriplate EMB grease (TENNANT part no. 01433-1).



HYDRAULICS

HYDRAULIC FLUID RESERVOIR

The reservoir is located in the engine compartment next to the radiator.

Mounted on top of the reservoir is a filler cap with a fluid level dipstick. The reservoir also has a hydraulic breather located next to the filler cap. Replace the hydraulic breather after every 800 hours of operation.



Check the hydraulic fluid level at operating temperature every 100 hours of operation. Make sure the hopper is down when checking hydraulic fluid level. The end of the dipstick is marked with FULL and ADD levels to indicate the level of hydraulic fluid in the reservoir.



Lubricate the filler cap gasket with a film of hydraulic fluid before putting the cap back on the reservoir.

ATTENTION! Do not overfill the hydraulic fluid reservoir or operate the machine with a low level of hydraulic fluid in the reservoir. Damage to the machine hydraulic system may result.

Drain and refill the hydraulic fluid reservoir with new hydraulic fluid every 800 hours of operation.

The hydraulic fluid filter is located at the bottom of the engine compartment. Replace the filter element every 800 hours of operation.

The reservoir has a built-in strainer outlet that filters hydraulic fluid before it enters the system. Replace the strainer every 800 hours of operation.

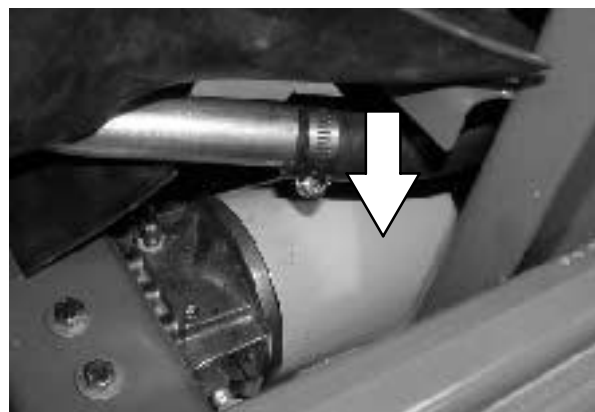

HYDRAULIC FLUID

The quality and condition of the hydraulic fluid play a very important role in how well the machine operates. TENNANT's hydraulic fluid is specially selected to meet the needs of TENNANT machines.

TENNANT's hydraulic fluids provide a longer life for the hydraulic components. There are two fluids available for different temperature ranges:

TENNANT part no.	Ambient Temperature
65869	above 7° C (45° F)
65870	below 7° C (45° F)

The higher temperature fluid has a higher viscosity and should not be used at the lower temperatures. Damage to the hydraulic pumps may occur because of improper lubrication.

The lower temperature fluid is a thinner fluid for colder temperatures.

If a locally-available hydraulic fluid is used, make sure the specifications match TENNANT hydraulic fluid specifications. Using substitute fluids can cause premature failure of hydraulic components.

European manufactured machines are filled with locally available hydraulic fluids. Check the label on the hydraulic fluid reservoir.

ATTENTION! Hydraulic components depend on system hydraulic fluid for internal lubrication. Malfunctions, accelerated wear, and damage will result if dirt or other contaminants enter the hydraulic system.

HYDRAULIC HOSES

Check the hydraulic hoses every 800 hours of operation for wear or damage.

Fluid escaping at high pressure from a very small hole can be almost invisible, and can cause serious injuries.

See a doctor at once if injury results from escaping hydraulic fluid. Serious infection or reaction can develop if proper medical treatment is not given immediately.

FOR SAFETY: When servicing machine, use cardboard to locate leaking hydraulic fluid under pressure.

If you discover a fluid leak, contact your mechanic/supervisor.

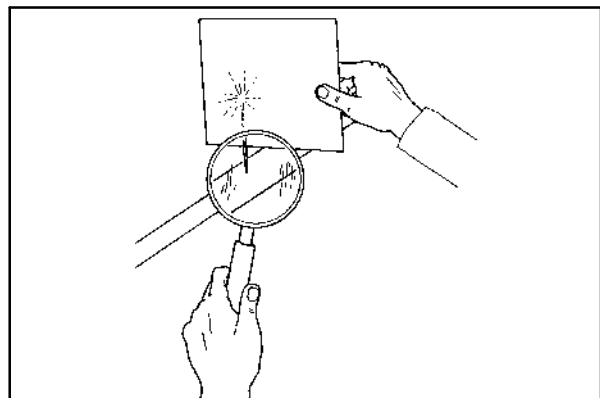

00002

PROPELLING MOTOR

Torque the shaft nut to 270 Nm (200 ft. lb) after the first 50-hours of operation, and every 800 hours there after.

ENGINE

COOLING SYSTEM

Check the coolant level in the reservoir daily. The coolant level must be between the two indicator marks when the engine is cold.

Check the radiator core exterior for debris every 100 hours of operation. Blow or rinse all dust, which may have collected on the radiator, in through the grille and radiator fins, opposite the direction of normal air flow. The grille and hydraulic cooler open for easier cleaning. Be careful not to bend the cooling fins when cleaning. Clean thoroughly to prevent the fins becoming encrusted with dust. Clean the radiator and cooler only after the radiator has cooled to avoid cracking.

FOR SAFETY: When servicing machine, wear eye and ear protection when using pressurized air or water.



Check the radiator coolant level every 100 hours of operation. Use clean water mixed with a permanent-type, ethylene glycol antifreeze to a -34°C (-30°F) rating.

FOR SAFETY: When servicing machine, avoid contact with hot engine coolant.



The coolant system must be completely filled with coolant to keep the engine from overheating. When filling the radiator with coolant, use the drain cock to ensure that all the air is out of the system.

Check the radiator hoses and clamps every 200 hours of operation. Tighten the clamps if they are loose. Replace the hoses and clamps if the hoses are cracked, harden, or swollen.

Flush the radiator and the cooling system every 800 hours of operation, using a dependable cleaning compound.



AIR FILTER

The engine air filter housing has a dust cap and a dry cartridge-type air filter element. Empty the dust cap daily. The air filter must be replaced whenever the filter element is damaged or after every 400 hours of operation. The air filters cannot be cleaned.

The machine is also equipped with a heavy duty air filter safety element. It is inside the standard element. Replace this element after the primary filter has been damaged or changed three times.



Do not remove the air filter element from the housing unless it is restricting air flow.



TO REPLACE AIR FILTER

1. Stop the engine and set the machine parking brake.

FOR SAFETY: Before leaving or servicing machine; stop on level surface, set parking brake, turn off machine and remove key.

2. Open the side door and engine cover.
3. Unlatch and gently remove the air cleaner dust cap. Empty the dust cap of any debris.
4. Gently pull the filter off the outlet tube and out of the housing. Avoid knocking the filter against the housing to reduce the amount of dust knocked off the filter.

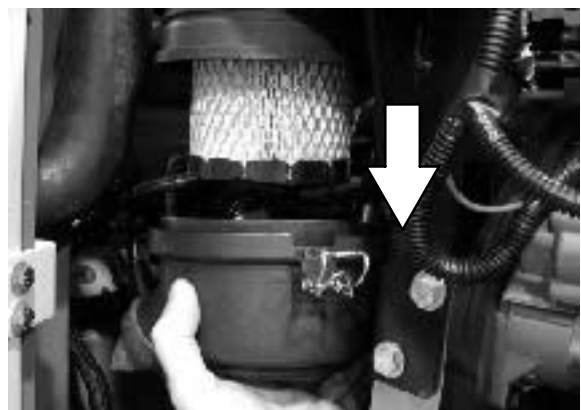

MAINTENANCE

5. Clean the sealing surface and the inside walls of the outlet tube with a clean cloth.
6. Replace the safety element after the primary filter has been changed three times.
7. Install the new filter by hand. Make certain that the new filter is all the way in the housing, and seated evenly before latching the dust cap in place.
8. Close the side door and engine cover.

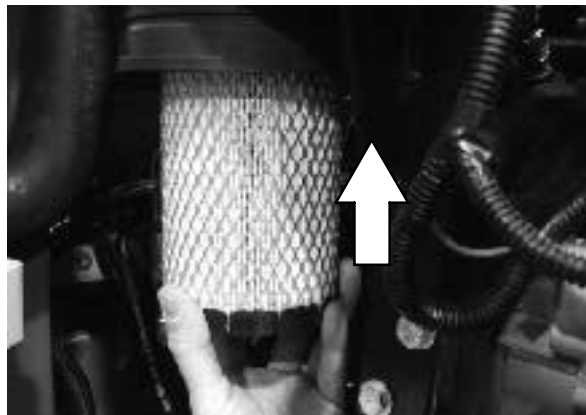
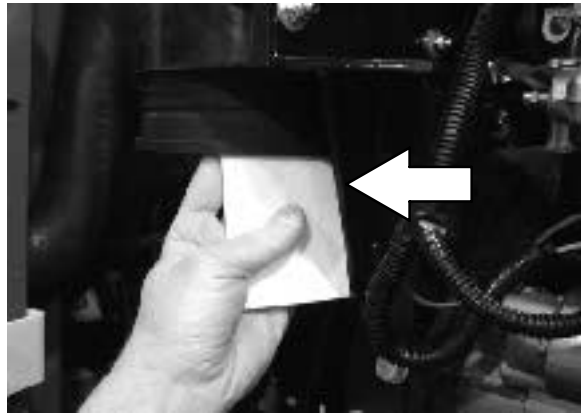

FUEL FILTER (GASOLINE)

The fuel filter traps fuel contaminants.

On machines serial number 024999 and below, the filter is located on the fuel line at the fuel tank. Replace the filter element after every 400 hours of operation.

On machines serial number (025000-029999), the filter is located on the fuel line inside the engine side door. Replace the filter element after every 800 hours of operation.

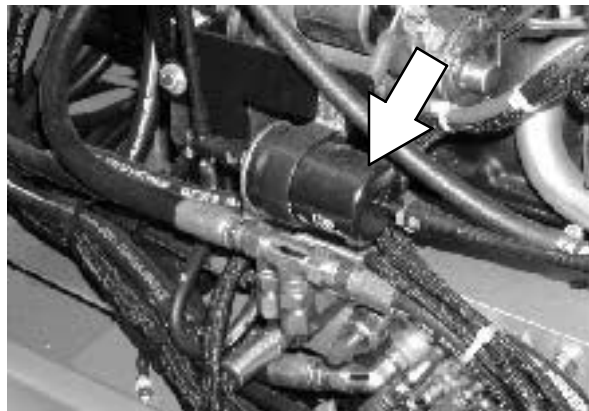

On machines serial number 030000 and above, the filter is located on the fuel line at the fuel tank. Replace the filter element after every 800 hours of operation.

FOR SAFETY: When servicing machine, keep flames and sparks away from fuel system service area. Keep area well ventilated.

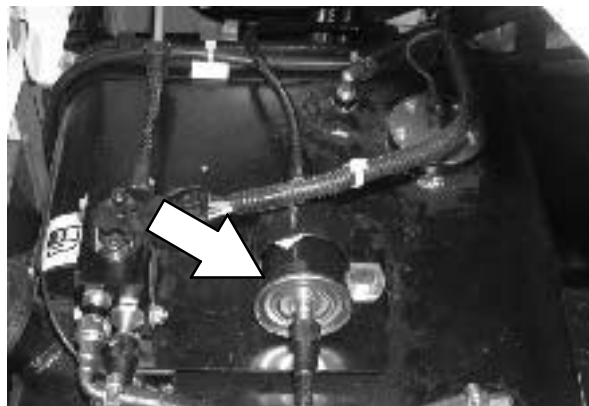

FUEL FILTER (LPG)

The fuel filter traps fuel contaminants. The fuel filter element is located inside the fuel lockoff valve on the LPG convertor going into the fuel injection system.

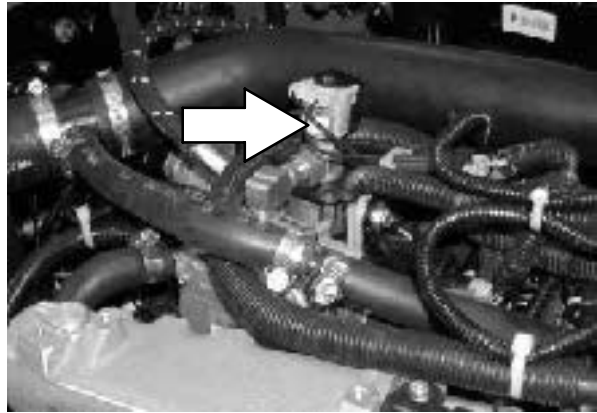

Replace the fuel filter element on machines serial number 025000 and above after every 400 hours of operation.

FOR SAFETY: When servicing machine, keep flames and sparks away from fuel system service area. Keep area well ventilated.



**ELECTRONIC PRESSURE REGULATOR (LPG)
(For machines serial number 030000 and above)**

Remove the sensor and drain the oil from the LPG electronic pressure regulator after every 100 hours of operation.

FOR SAFETY: When servicing machine, keep flames and sparks away from fuel system service area. Keep area well ventilated.

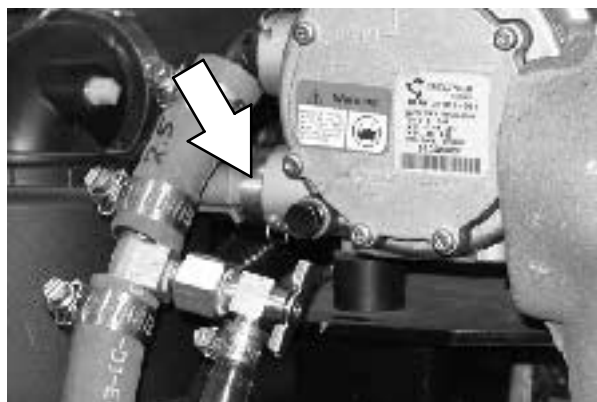

ELECTRONIC FUEL INJECTION (EFI)

The electronic fuel injection system requires no adjustment.

The fuel injection system is equipped with a “manifold absolute pressure sensor” (MAP Sensor). The MAP sensor senses barometric pressure and automatically corrects the fuel system calibration for changes in altitude. This means the air/fuel mixture will always be optimized, regardless of elevation (or barometric pressure), however, the engine will still lose 3.5% power for every 1000 ft increase in elevation.

The Idle speed on machines serial number 024999 and below is set at 1350 ± 50 rpm

The Idle speed on machines serial number 025000 and above is set at 950 ± 50 rpm

SPARK PLUGS

Clean or replace, and set the gap of the spark plugs every 400 hours of operation.

The proper spark plug gap is 0.8–0.9 mm (0.032–0.036 in).

VALVE TAPPET CLEARANCE

The intake and exhaust valve clearances need no adjustment.

CRANKCASE VENTILATION SYSTEM

Replace the oil fill cap after every 400 hours of operation.

TIMING BELT

Check the timing belt after every 800 hours of operation.

Replace the timing belt on machines serial number 024999 and below after every 1000 hours of operation.

Replace the timing belt on machines serial number 025000 and above after every 2000 hours of operation.

BATTERY

The battery for the machine is a low maintenance battery. Do not add water to the battery or remove the battery vent plugs.

After the first 50 hours of operation, and every 800 hours after that, clean and tighten the battery connections.

For Safety: When servicing machine, avoid contact with battery acid.



BELTS AND CHAINS

ENGINE FAN BELT

The engine fan belt is driven by the engine crankshaft pulley and drives the engine fan and alternator pulleys. Proper belt tension is obtained when the belt deflects 6 mm (0.25 in) from a force of 3 kg (5 lb) applied at the mid-point of the longest span.

Check and adjust the belt tension every 200 hours of operation.

 **WARNING: Moving belt and fan. Keep away.**

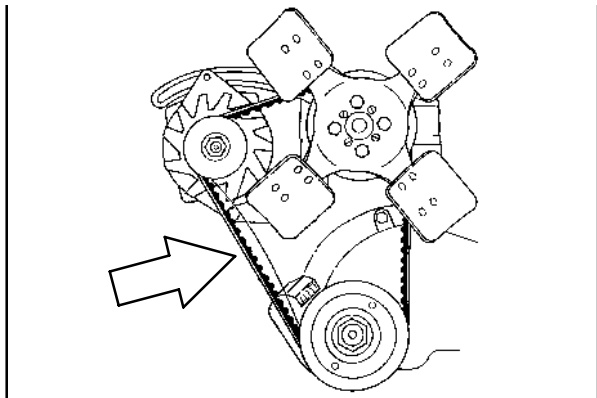

00577

STATIC DRAG CHAIN

A static drag chain prevents the buildup of static electricity in the machine. The chain is attached to the machine by a rear main brush skirt retaining bolt.

Make sure the chain is touching the floor at all times.



DEBRIS HOPPER

HOPPER DUST FILTER

The dust filter filters the air pulled up from the hopper. The dust filter is equipped with a shaker to remove the accumulated dust particles. The dust filter shaker is operated by the filter shaker switch.

The standard dust filter works very well for normal sweeping applications. The synthetic filter works well for humid or wet applications. The surface load filter works well for heavy fine dust applications. It keeps the dust on the outer surface of the filter, making filter shaking more effective.

Shake the dust filter before emptying the hopper and at the end of every work shift. Check and clean or replace the dust filter every 100 hours of operation.

To clean the dust filter, use one of the following methods:

- SHAKING - Press the filter shaker switch.
- TAPPING - Tap the filter gently on a flat surface with the dirty side down. Do not damage the edges of the filter element or the filter will not seat properly in the filter frame.
- AIR - Always wear eye protection when using compressed air. Blow air through the dust filter opposite the direction of the arrows. Never use more than 690kPa (100 psi) of air pressure and never closer than 50 mm (2 in) away from the filter. This may be done with the dust filter in the machine.

FOR SAFETY: When servicing machine, wear eye and ear protection when using pressurized air or water.

- WATER - Rinse the synthetic filter with a low pressure garden hose through the dust filter opposite the direction of the arrows. Both the standard and surface load dust filters can also be rinsed, but the filters will degrade with each rinsing and should be replaced after rinsing five times.

NOTE: Be sure the dust filter is dry before reinstalling it in the machine.



TO REPLACE HOPPER DUST FILTER

1. Stop the engine and set the machine parking brake.

FOR SAFETY: Before leaving or servicing machine; stop on level surface, set parking brake, turn off machine and remove key.

2. Open the hopper cover.
3. Disconnect the filter shaker wire. For machines with the metal hopper, lift the dust filter cover for access to the wire.

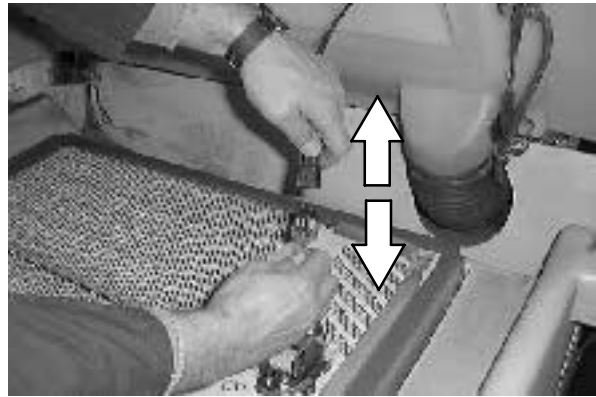

4. Lift the dust filter element assembly out from the hopper.



5. Cut the four cable ties that are holding the filter shaker plate to the element.

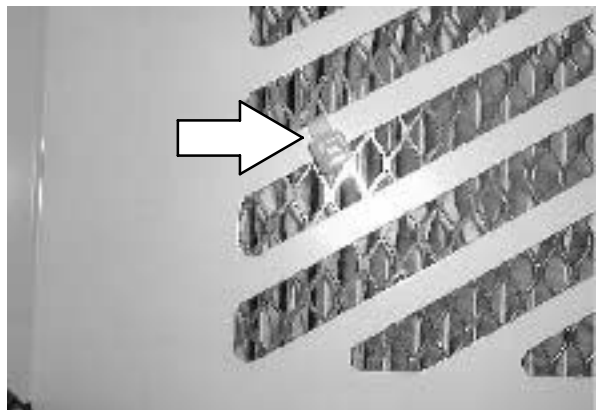

MAINTENANCE

6. Remove the filter shaker plate from the dust filter element.
7. Clean or discard the dust filter element as required.

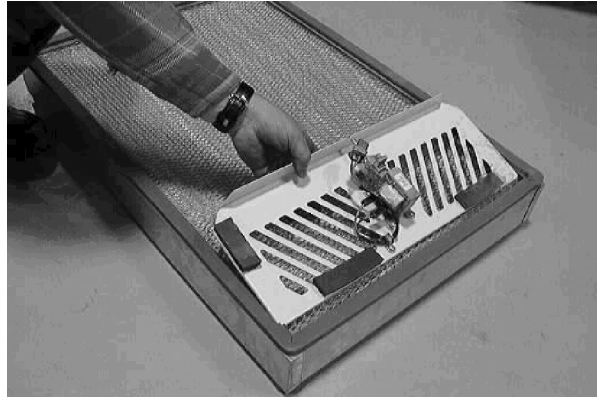

8. Remove the shipping tab from the dust filter element if a new element will be inserted into the machine.

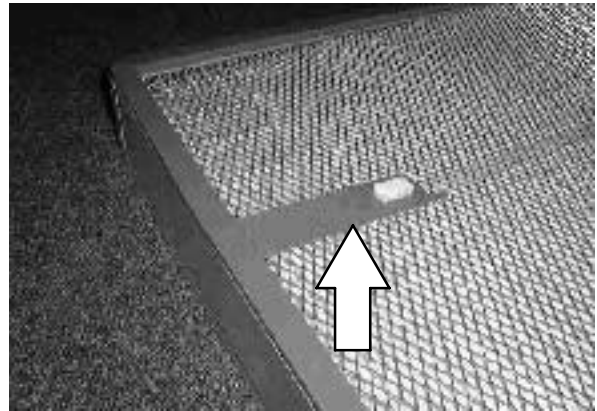

9. Place the filter shaker plate onto the new or cleaned dust filter element. Make sure the lip on the filter shaker plate is fastened over the lip on the dust filter element.

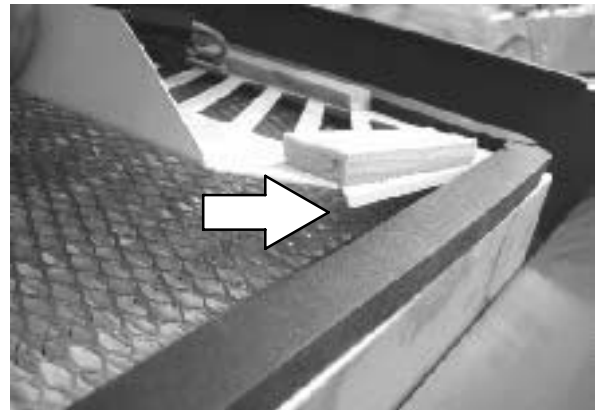

10. Insert the pin from the shaker into the hole on the dust filter element comb.

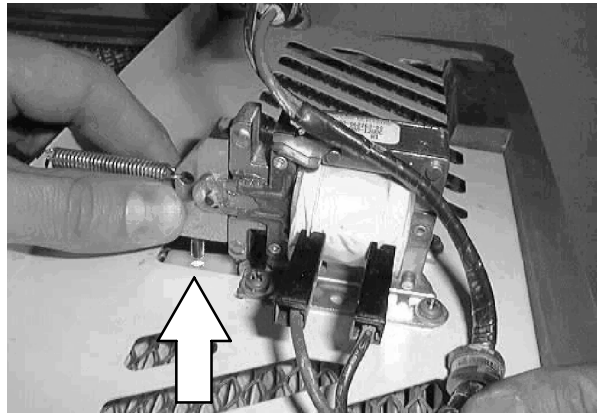

11. Check the shaker solenoid gap with the end of the shipping tab. The gap should be the same width as the tab. If it is not, loosen the mounting screws, adjust the gap by repositioning the shaker solenoid, then tighten the screws.



12. Place the dust filter element assembly into the hopper and reconnect the filter shaker wire. Fasten the assembly to the element with four new cable ties.

13. Close the hopper cover.

THERMO SENTRY

The Thermo Sentry senses the temperature of the air pulled up from the hopper. If there is a fire in the hopper, the Thermo Sentry stops the vacuum fan and cuts off the air flow.

Reset the Thermo Sentry by pushing in its reset button.

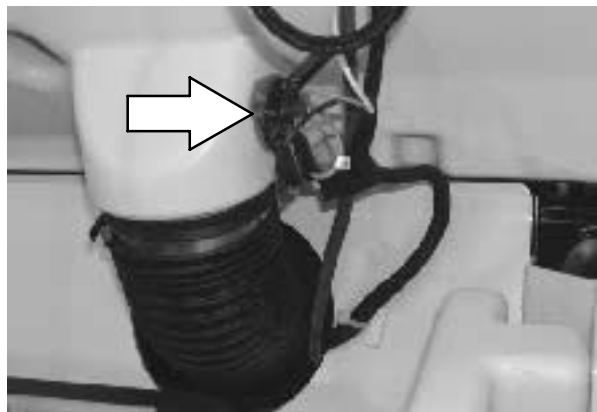

BRUSHES

MAIN BRUSH

The main brush is cylindrical and spans the width of the machine, sweeping debris into the hopper.

Check the brush daily for wear or damage. Remove any string or wire tangled on the main brush, main brush drive hub, or main brush idler hub.

Check the main brush pattern daily. The pattern should be 50 to 65 mm (2.0 to 2.5 in) wide with the main brush in the **Down** position.

Adjust the main brush pattern by setting the main brush adjustment plate.

Note the length of the main brush bristles with the color band on the brush idler plate before moving the main brush adjustment knob.

Align the pointer from the plate located under the knob, to match the same color band as the brush idler plate.

Rotate the main brush end-for-end every 50 hours of operation for maximum brush life and best sweeping performance.

Replace the main brush when the remaining bristles measure 50 mm (2.0 in) in length.

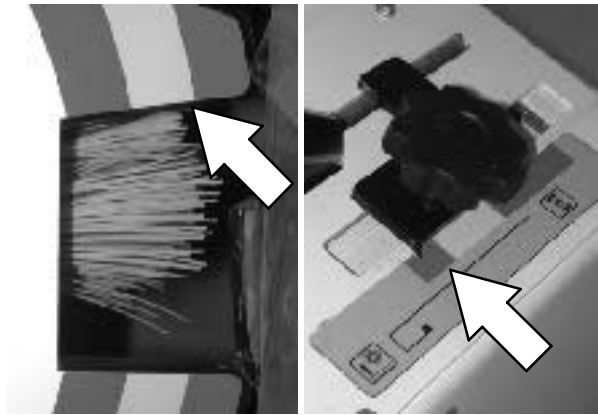

TO REPLACE MAIN BRUSH

1. Stop the engine and set the machine parking brake.

FOR SAFETY: Before leaving or servicing machine; stop on level surface, set parking brake, turn off machine and remove key.

2. Raise the main brush.
3. Open the right side main brush access door.
4. Unlatch and remove the brush idler plate.

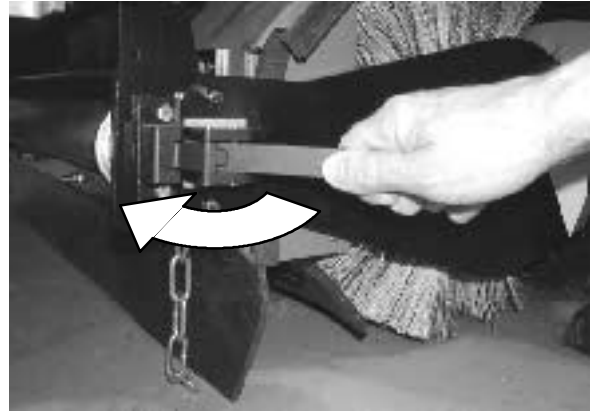

5. Grasp the main brush; pull it off the brush drive plug and out of the main brush compartment.
6. Put the new or rotated end-for-end main brush on the floor next to the access door.
7. Slide the main brush onto the drive plug. Rotate the brush until it engages the drive plug, and push it all the way onto the plug.



8. Replace the brush idler plate. Align the holes on the top and bottom of the brush idler plate latch with the pins on the machine frame. Secure the plate in position with the brush idler plate latch.
9. Close the right side main brush access door.

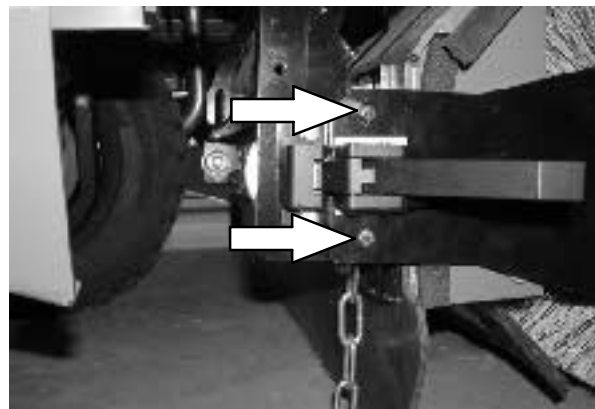

MAINTENANCE

TO CHECK AND ADJUST MAIN BRUSH PATTERN

1. Apply chalk, or some other material that will not blow away easily, to a smooth, level floor.
2. Raise the side brush and main brush and position the main brush over the chalked area.
3. Start the main brush.
4. Lower the main brush for 15 to 20 seconds while keeping a foot on the brakes to keep the machine from moving. This will lower the rotating main brush.

NOTE: If chalk or other material is not available, allow the brushes to spin on the floor for two minutes. A polish mark will remain on the floor.

5. Raise the main brush.
6. Stop the main brush.
7. Drive the machine off the test area.
8. Observe the width of the brush pattern. The proper brush pattern width is 50 to 65 mm (2.0 to 2.5 in).

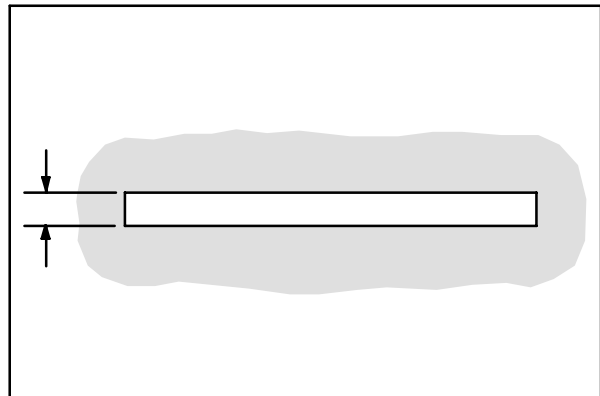

00582

9. To increase the width of the main brush pattern, loosen the main brush adjustment knob and slide the main brush adjustment plate forward 7 to 14 mm (0.25-0.50 in).

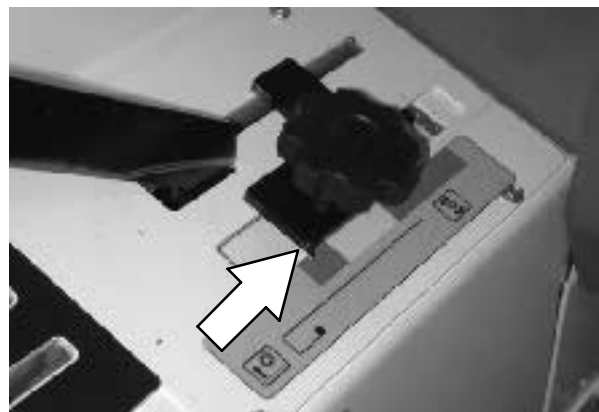

To decrease the width of the main brush pattern, loosen the main brush adjustment knob and slide the main brush adjustment plate back 7 mm (0.25 in).

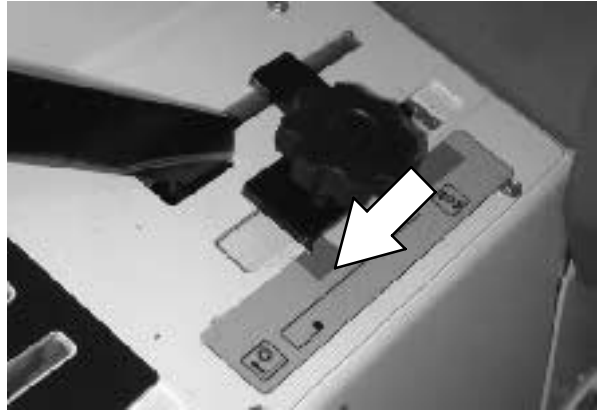

If the main brush pattern is tapered, more than 15 mm (0.5 in) on one end than the other, adjust the taper with the taper adjustment bracket at the drive end of the brush.

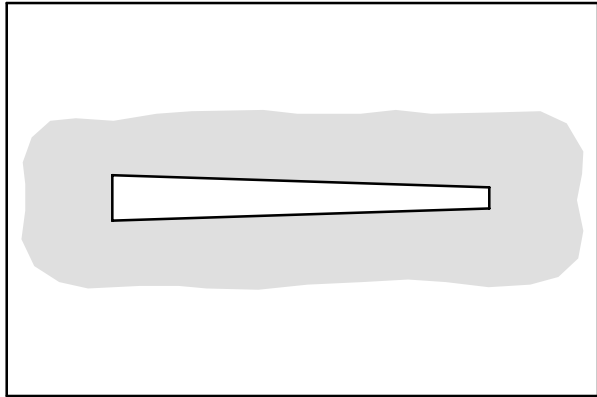

00601

A. Loosen the shaft bearing bracket mounting bolts.

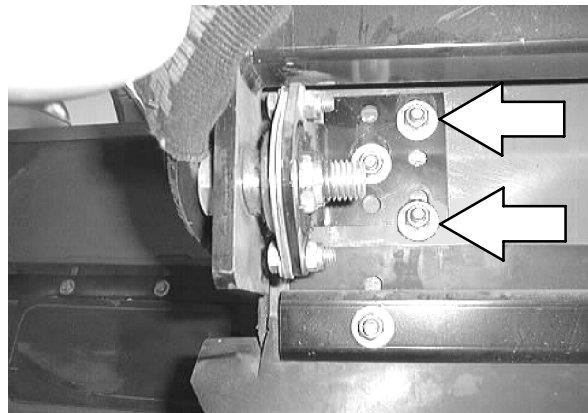

B. Move the bracket up or down in the slots and tighten the mounting bolts.

C. Check the main brush pattern and readjust as necessary. Set the main brush adjustment knob to match the same color band as the brush idler plate.

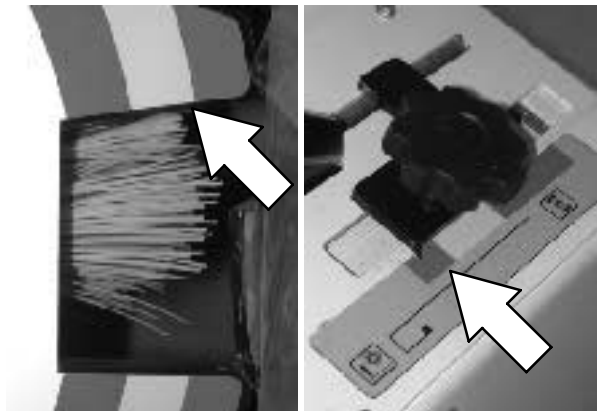

SIDE BRUSH

The side brush sweeps debris along edges into the path of the main brush.

Check the brush daily for wear or damage. Remove any string or wire found tangled on the side brush or side brush drive hub.

Check the side brush pattern daily. The side brush bristles should contact the floor in a 10 o'clock to 3 o'clock pattern when the brush is in motion.

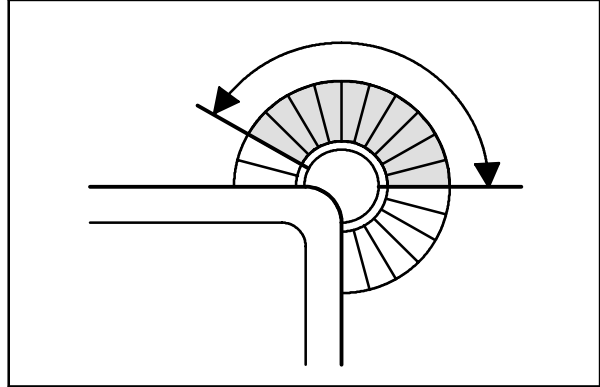

350327

Adjust the side brush pattern by the side brush down pressure knob. Turn the knob counter-clockwise to increase the brush contact with the sweeping surface, and clockwise to decrease the brush contact with the sweeping surface.

The side brush should be replaced when it no longer sweeps effectively for your application. A guideline length is when the remaining bristles measure 50 mm (2 in) in length. You may change the side brush sooner if you are sweeping light litter, or wear the bristles shorter if you are sweeping heavy debris.



TO REPLACE SIDE BRUSH

1. Empty the debris hopper.
2. Set the machine parking brake.
3. Stop the engine.

FOR SAFETY: Before leaving or servicing machine; stop on level surface, set parking brake, turn off machine and remove key.

4. Raise the side brush.
5. Remove the side brush retaining pin from the side brush drive shaft by pulling the pin keeper off over the end of the pin.
6. Slide the side brush off the side brush drive shaft.

NOTE: Remove the drive hub and put it on the new brush if one is not installed.

7. Slide the new side brush onto the side brush drive shaft.
8. Insert the side brush retaining pin through the side brush hub and shaft.
9. Secure the pin by clipping the pin keeper over the end of the pin.
10. Disengage the hopper support bar and lower the hopper.
11. Adjust the side brush pattern with the side brush down pressure knob.

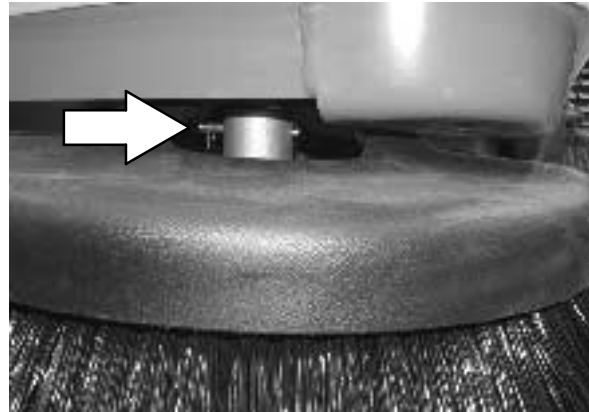

SIDE BRUSH GUARD

Rotate the side brush guard 90° every 200 hours of operation. Replace the brush guard after all four sides have been used.



SKIRTS AND SEALS

HOPPER LIP SKIRTS

The hopper lip skirts are located on the bottom rear of the hopper. The skirts float over debris and help deflect that debris into the hopper. The hopper lip skirts consist of five bottom lip segments and two additional side lip segments.

Check the hopper lip skirts for wear or damage daily.

Replace the hopper lip skirts when they no longer touch the floor.



HOPPER SIDE SKIRT

The hopper side skirt is located on the left side of the hopper.

Check the hopper side skirt for wear or damage daily.

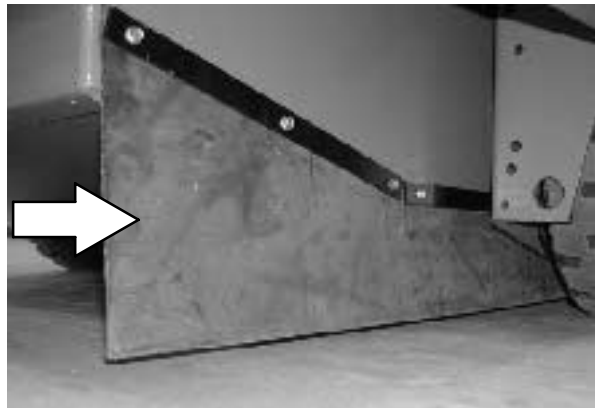

BRUSH DOOR SKIRTS

The brush door skirts are located on the bottom of each of the two main brush doors. The skirts should clear the floor by 3 to 6 mm (0.12 to 0.25 in).

Check the skirts for wear or damage and adjustment daily.

NOTE: The brush door skirts have slotted holes to allow for a ground clearance adjustment. The door must be closed for proper adjustment.

NOTE: Rear tire pressure will affect skirt clearances.



REAR SKIRTS

The two rear skirts are located on the bottom rear of the main brush compartment. The vertical skirt should clear the floor up to 5 mm (0.25 in) in dusty conditions, and touch the floor otherwise. The recirculation skirt is self-adjusting.

Check the skirts for wear or damage and adjustment daily.

NOTE: Rear tire pressure will affect skirt clearances.

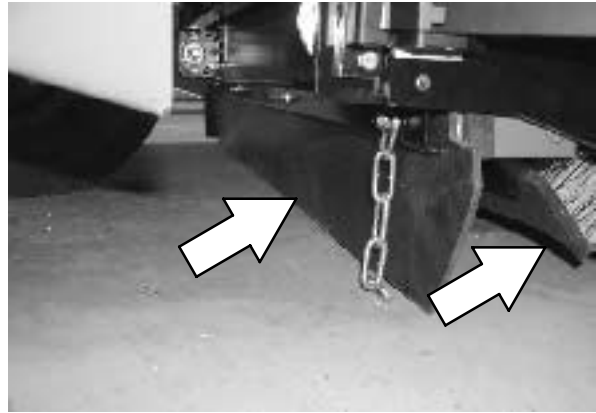

SIDE BRUSH DUST CONTROL SKIRTS (OPTION)

The side brush dust control skirts wrap around the side brush and the bottom of the hopper.

Check the side brush dust control skirts for wear or damage daily.

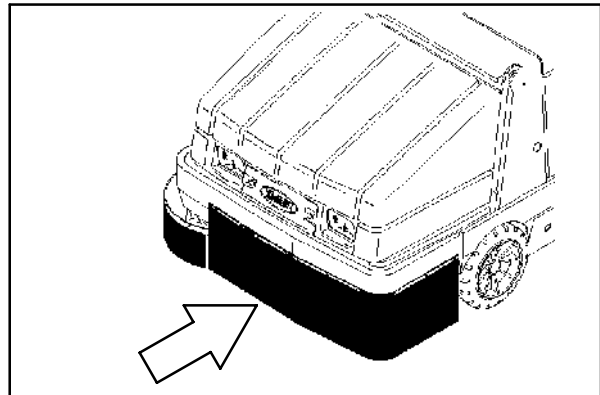

BRUSH DOOR SEALS

The brush door seals are located on both main brush doors and on corresponding portions of the main frame.

Check the seals for wear or damage every 100 hours of operation.



MAINTENANCE

HOPPER SEALS

The hopper seals are located on the front and side portions of the machine frame that contact the hopper.

Check the seals for wear or damage every 100 hours of operation.

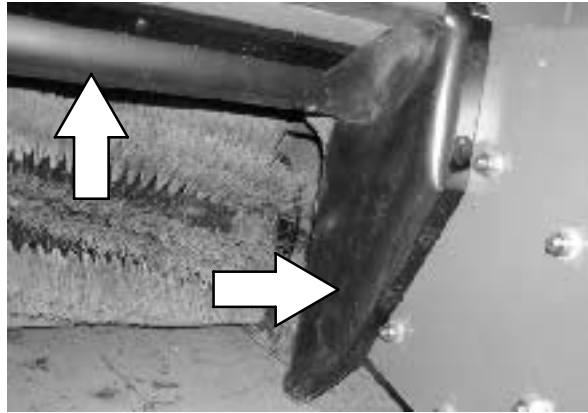

HOPPER DOOR SEALS

The hopper door seals are located on the hopper door. They seal the hopper when the hopper door is closed.



Check the seals for wear or damage every 100 hours of operation.

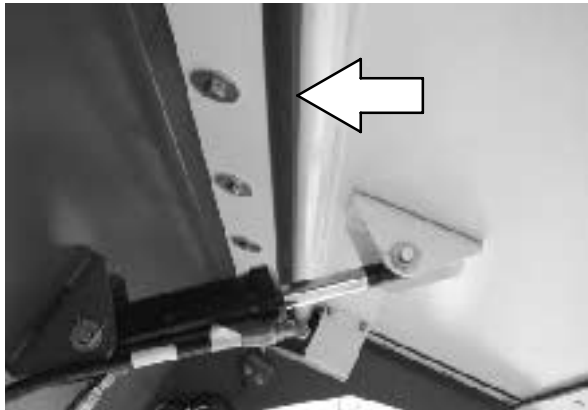

HOPPER FILTER SEALS

The hopper filter seals are mounted on the hopper directly below the filter. They are also mounted on both sides of the hopper dust filter element and on the edges of the filter shaker.

Check the seals for wear or damage after every 100 hours of operation. You can reach the seals by lifting the dust filter cover and removing the filter element.

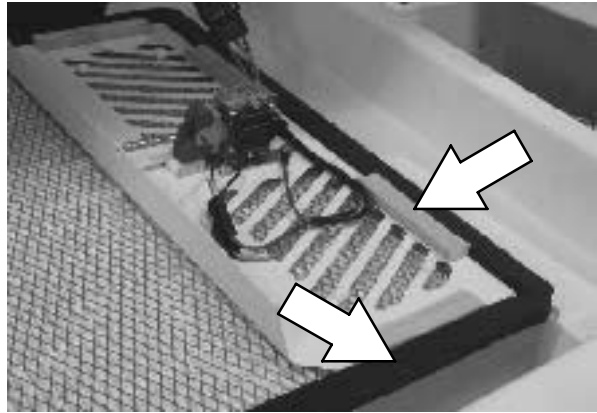
**HOPPER INSPECTION DOOR SEAL**

The hopper inspection door seal is located on the hopper and seals the front of the debris hopper.

Check the seal for wear or damage every 100 hours of operation.

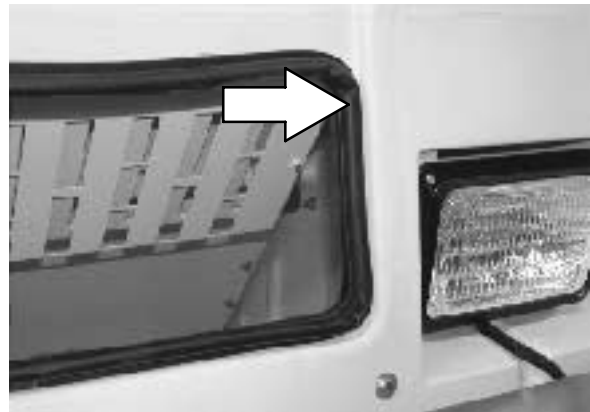
**VACUUM WAND DOOR SEALS (OPTION)**

The vacuum wand door seal is located on the back side of the vacuum wand door (option). It seals the vacuum wand opening when the vacuum wand (option) is not in use.

Check the seal for wear or damage every 100 hours of operation.



BRAKES AND TIRES

SERVICE BRAKES

The mechanical service brakes are located on the front wheels. The brakes are operated by the foot brake pedal and connecting cables.

Check the brake adjustment every 200 hours of operation. The brake pedal should not travel more than 25 mm (1 in) to fully engage the brakes.

PARKING BRAKE

The parking brake is set with the parking brake lever that activates the service brakes.

Adjust the parking brake whenever it becomes very easy to set the parking brake, when the machine rolls after setting the parking brake, and every 200 hours of operation. The parking brake may be tightened by turning the knurled knob on the end of the parking brake clockwise.



TIRES

The standard front machine tires are solid. The standard rear machine tire is pneumatic.

Check the rear tire pressure every 100 hours of operation. The proper tire air pressure is 790 ± 35 kPa (115 ± 5 psi).



REAR WHEEL

Torque the rear wheel nuts in a star pattern twice to 142 to 157 Nm (105 to 115 ft. lb) after the first 50-hours of operation, and every 800 hours there after.

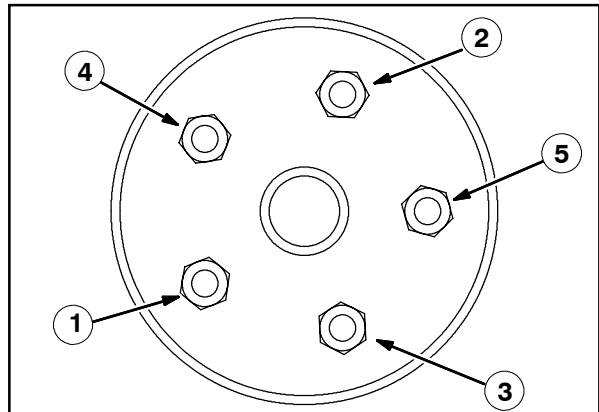

PUSHING, TOWING, AND TRANSPORTING THE MACHINE

PUSHING OR TOWING THE MACHINE

If the machine becomes disabled, it can be pushed from the front or rear, but towed only from the rear.

The propelling pump has a bypass valve to prevent damage to the hydraulic system when the machine is being pushed or towed. This valve allows a disabled machine to be moved for a *very short distance* and at a speed to not exceed 1.6 kph (1 mph). The machine is NOT intended to be pushed or towed a long distance or at a high speed.

ATTENTION! Do not push or tow machine for a long distance and without using the bypass valve, or the machine hydraulic system may be damaged.

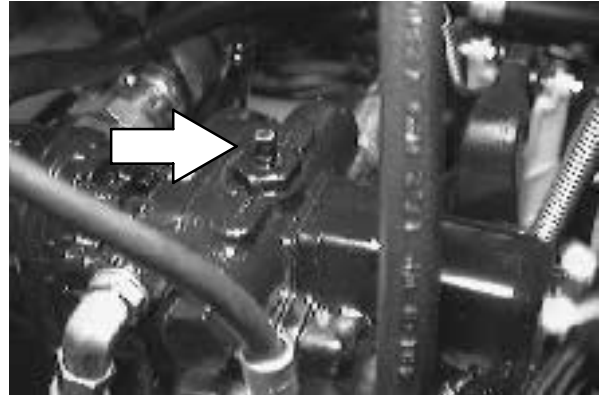

Turn the bypass valve 90° from the normal position before pushing or towing the machine. **The illustration shows the bypass valve in the pushing or towing position.**

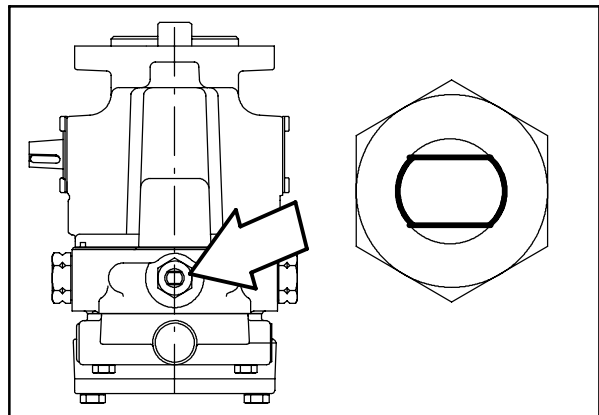

TRANSPORTING THE MACHINE

1. Position the rear of the machine at the loading edge of the truck or trailer.

FOR SAFETY: Use truck or trailer that will support the weight of the machine.

NOTE: Empty the hopper before transporting the machine.

MAINTENANCE

2. If the loading surface is not horizontal or is higher than 380 mm (15 in) from the ground, use a winch to load machine.

If the loading surface is horizontal AND is 380 mm (15 in) or less from the ground, the machine may be driven onto the truck or trailer.

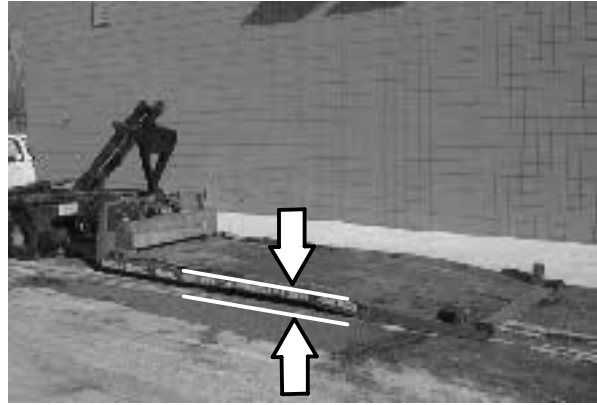

3. To winch the machine onto the truck or trailer, attach the winching chains in the holes at the bottom of the rear bumper.

If the machine has the optional rear tie down brackets, attach the winching chains to them.

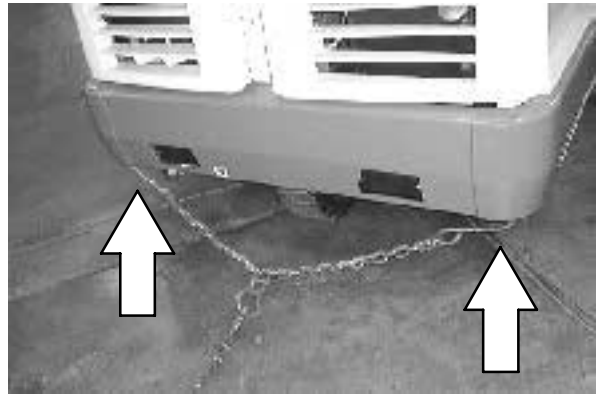

4. Turn the bypass valve 90° from the normal position before winching the machine onto the truck or trailer. See *PUSHING OR TOWING THE MACHINE* section of this manual. Make sure the machine is centered.

FOR SAFETY: When loading machine onto truck or trailer, use winch. Do not drive the machine onto the truck or trailer unless the loading surface is horizontal AND is 380 mm (15 in) or less from the ground.

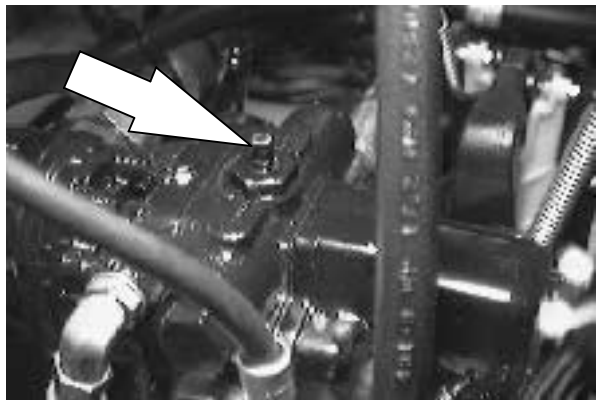

5. Position the machine onto the truck or trailer as far as possible. If the machine starts to veer off the centerline of the truck or trailer, stop and turn the steering wheel to center the machine.
6. Set the parking brake and block the machine tires. Tie down the machine to the truck or trailer before transporting.

The front tie down locations are the holes in the wheel pockets at the front of the machine frame.

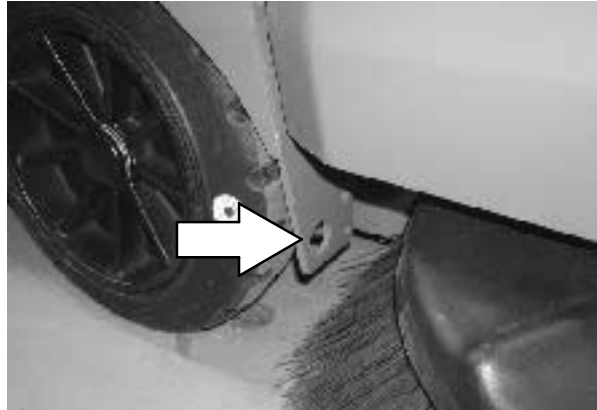

If the machine has the optional front tie down brackets above the front tires, attach the winching chains to them.

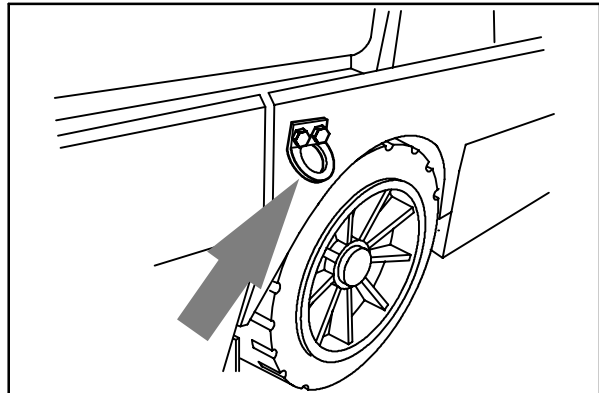

08152

The rear tie down locations are in the holes at the bottom of the rear bumper. If the machine has the optional rear tie down brackets, use them to tie down the machine.

7. If the loading surface is not horizontal or is higher than 380 mm (15 in) from the ground, use a winch to unload machine.

If the loading surface is horizontal AND is 380 mm (15 in) or less from the ground, the machine may be driven off the truck or trailer.

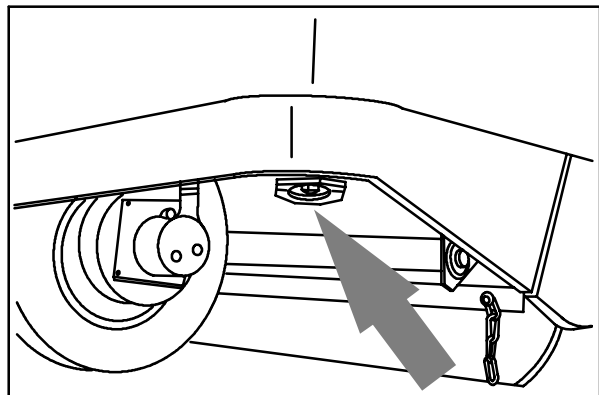

08151

FOR SAFETY: When unloading machine off truck or trailer, use winch. Do not drive the machine off the truck or trailer unless the loading surface is horizontal AND 380 mm (15 in) or less from the ground.

MACHINE JACKING

Empty the hopper before jacking the machine. You can jack up the machine for service at the designated locations. Use a hoist or jack that will support the weight of the machine. Always stop the machine on a flat, level surface and block the tires before jacking the machine up.

The front jacking locations are on the flat bottom edge of the front of the machine frame next to the front tires.

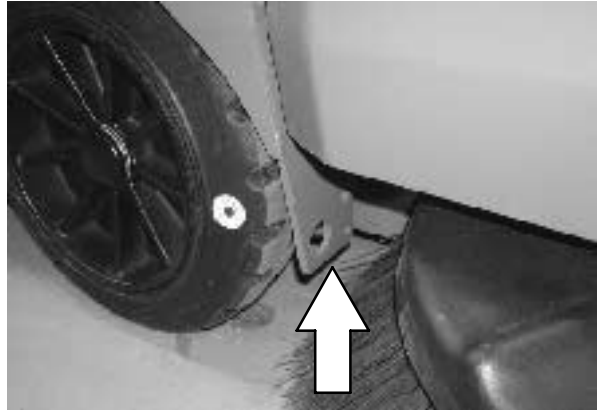

The rear jacking location is the middle flat bottom edge of the rear bumper between the taillights.

FOR SAFETY: When servicing machine, block machine tires before jacking machine up.

FOR SAFETY: When servicing machine, jack machine up at designated locations only. Block machine up with jack stands.



STORING MACHINE

Before storing the machine for an extended period of time, the machine needs to be prepped to lessen the chance of rust, sludge, and other undesirable deposits from forming. Contact TENNANT service personnel.

SPECIFICATIONS

GENERAL MACHINE DIMENSIONS/CAPACITIES

Item	Dimension/capacity
Length	2360 mm (93 in)
Width	1585 mm (62.5 in)
Height	1470 mm (58 in)
Height with overhead guard	2080 mm (82 in)
Height with overhead guard and hazard light	2270 mm (89.5 in)
Height with cab	2100 mm (82.62 in)
Height with cab and hazard light	2285 mm (90 in)
Track	1345 mm (53 in)
Wheelbase	1135 mm (44.75 in)
Main brush diameter	355 mm (14 in)
Main brush length	1145 mm (45 in)
Side brush diameter	660 mm (26 in)
Sweeping path width	1145 mm (45 in)
Sweeping path width with side brush	1560 mm (61.5 in)
Main brush pattern width	50 to 65 mm (2.0 to 2.5 in)
Hopper weight capacity	545 kg (1200 lb)
Hopper volume capacity	395 L (14 cu ft)
Dust filter area	7 m ² (77.6 sq ft)
GVWR	1927 kg (4250 lb)
Sound level	80 dBa
Ceiling height minimum dumping clearance	2745 mm (9 ft)

GENERAL MACHINE PERFORMANCE

Item	Measure
Maximum forward speed	16.1 kmh (10 mph)
Maximum reverse speed	4.0 kmh (2.5 mph)
Minimum aisle turn width, left	2870 mm (113 in)
Minimum aisle turn width, right	4725 mm (186 in)
Maximum rated climb and descent angle	10° (Full Hopper), 15° (Empty Hopper)

TIRES

Location	Type	Size	Pressure
Front (2)	Solid	5 x 18 in	-
Rear (1)	Pneumatic	4.5 x 18 in	790 ± 35 kPa (115 ± 5 psi)

SPECIFICATIONS

POWER TYPE

Engine GM 1.6	Type	Ignition	Cycle	Aspiration	Cylinders	Bore	Stroke	
	Piston	Distributor-less-type spark	4	Natural	4	79 mm (3.11 in)	81.5 mm (3.21 in)	
	Displacement		Net power, governed			Net power, maximum		
	1600 cc (98 cu in)		27.75 kw (37 hp) @ 2400 rpm			41.25 kw (55 hp) @ 4000 rpm		
	Fuel		Cooling system			Electrical system		
	Gasoline, 87 octane minimum, unleaded. Fuel tank: 36 L (9.6 gal)		Water/ethylene glycol antifreeze			12 V nominal		
	LPG, Fuel tank: 15 kg (33 lb)		Total: 7.5 L (2 gal) Radiator: 3.8 L (1 gal)			55 A alternator		
	Idle speed, no load							
	1350 ± 50 rpm machines serial number (000000-024999)							
	950 ± 50 rpm machines serial number (025000- 030000)							
	1350 ± 50 rpm machines serial number (030000-)							
	Engine GM 1.6	(Fast 1) governed speed, under load						
		2000 ± 50 rpm						
(Fast 2) governed speed, under load								
2400 ± 50 rpm								
Spark plug gap		Firing order			Valve clearance, cold			
1 mm (0.035 in)		1-3-4-2			No adjustment			
Engine lubricating oil with filter								
3.3 L (3.7 qt) 10W-30 SAE-SG/SH 0° f and above								
3.3 L (3.7 qt) 5W-30 SAE-SG/SH 0° f and below								

STEERING

Type	Power source	Emergency steering
Rear wheel, hydraulic cylinder and rotary valve controlled	Hydraulic accessory pump	Manual

HYDRAULIC SYSTEM

System	Capacity	Fluid Type
Hydraulic reservoir	24.6 L (6.5 gal)	TENNANT part no. 65869 - above 7° C (45° F)
Hydraulic total	N/A L (N/A gal)	TENNANT part no. 65870 - below 7° C (45° F)

BRAKING SYSTEM

Type	Operation
Service brakes	Mechanical drum brakes (2), one per front wheel, cable actuated
Parking brake	Utilize service brakes, cable actuated

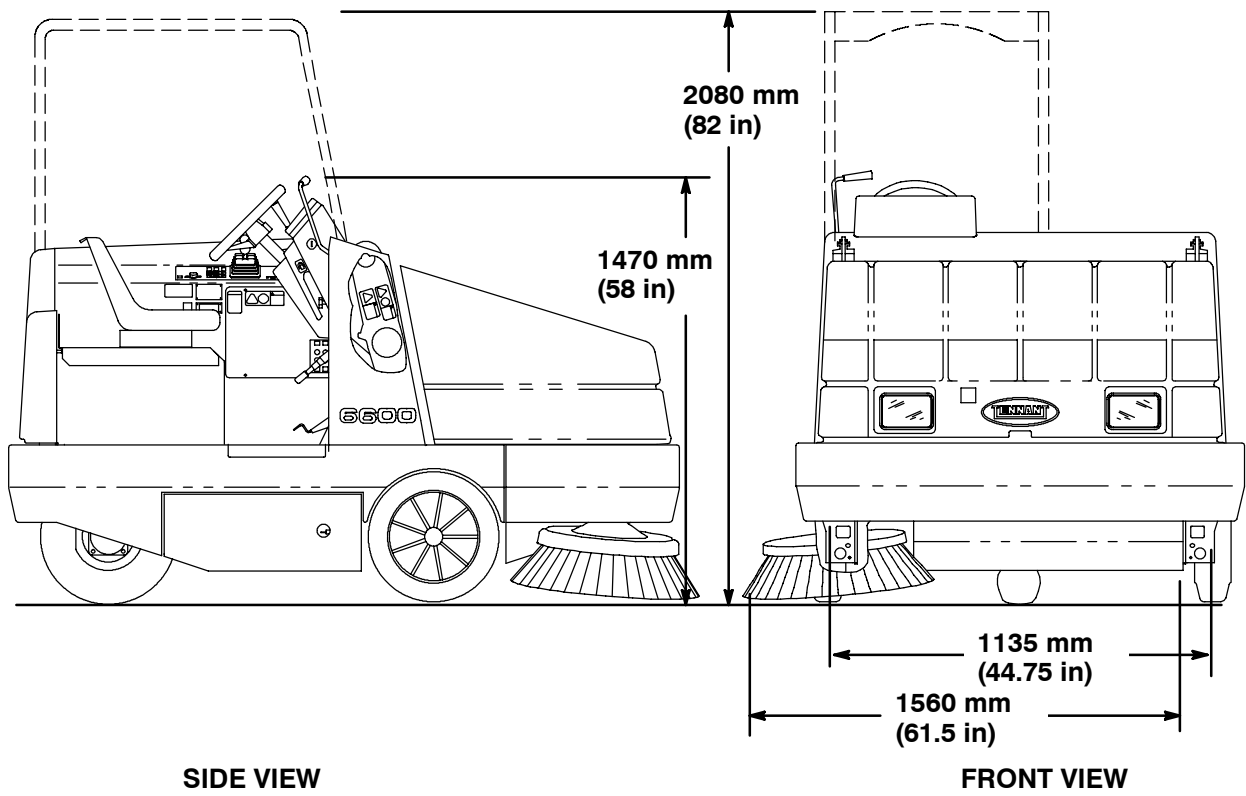
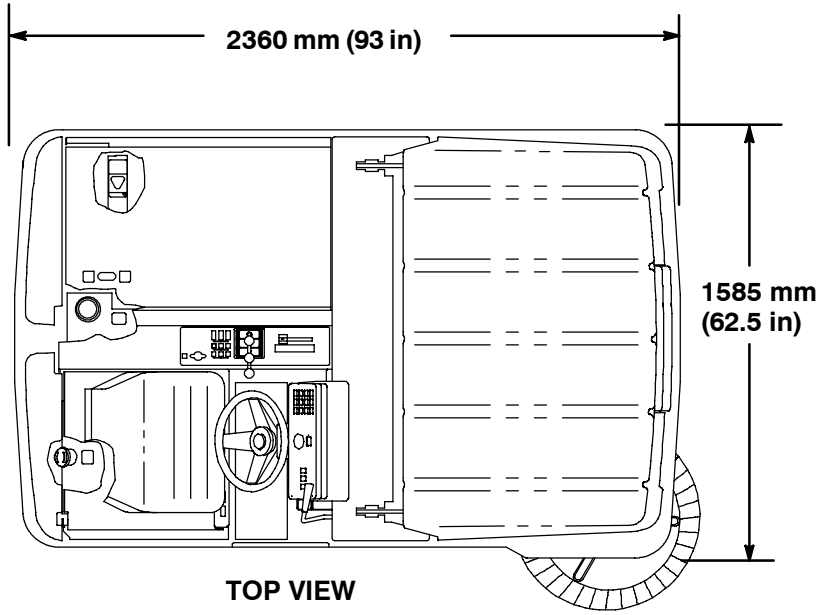

MACHINE DIMENSIONS

354037

A

Air conditioning switch (option), 35
 Air filter, 73
 Dust cap, 73
 Element, 73
 Aisle turn, 97

B

Battery, 77
 Charging system, Light, 20
 Bearings
 Front wheel, 69
 Hopper, 69
 Belts, 77
 Engine fan belt, 77
 Blower wand, 62 – 63
 Brake pedal, 13
 Brakes, 37, 52, 92
 Parking, Adjustment, 92
 Service, 92
 System specifications, 98
 Brushes, 42 – 43, 82 – 86
 Adjusting main brush taper, 85 – 87
 Checking main brush pattern, 84 – 86
 Checking side brush pattern, 86
 Door latch, 32
 Door seals, 89
 Door skirts, 88
 Main brush, 82 – 85
 Main brush bristle length, 82
 Maintenance, 37, 52
 Pattern adjustment, 37, 52
 Replacing main brush, 83 – 84
 Replacing side brush, 87
 Side brush, 86 – 87
 Side brush bristle length, 86
 Button, Horn, 17
 Bypass valve, 93

C

Cab
 Air conditioning switch, 35
 Dome light switch, 36
 Door latch, 32
 Heater knob (option), 35
 Pressurizer switch, 36
 Windshield wiper switch, 35

Capacities, 97
 Chains, 77
 Static drag, 77
 Changing LPG fuel tank, 38 – 39
 Charging system light, 20
 Check engine, Light, 22
 Check engine light, 22
 Circuit breakers, 30, 31
 Clogged filter light, 22
 Control panel
 Clogged filter light, 22
 Engine oil pressure, 20, 21
 Engine speed switch, 25
 Fuel level gauge, 23
 Hopper door light, 20
 Hopper temperature light, 20
 Hourmeter, 23
 LP Fuel light, 21
 Operating/hazard lights switch, 24
 Vacuum fan/filter shaker switch, 24
 Controls
 Air conditioning switch (option), 35
 Brake pedal, 13
 Charging system light, 20
 Check engine light, 22
 Circuit breakers, 30, 31
 Clogged filter light, 22
 Directional pedal, 12
 Dome light switch, 36
 Engine oil pressure light, 21
 Engine speed switch, 25
 Fuel level gauge, 23
 Heater knob (option), 35
 High engine temperature light, 22
 Hopper door lever, 15
 Hopper door light, 20
 Hopper lift lever, 16
 Hopper temperature light, 20
 Horn button, 17
 Hourmeter, 23
 Ignition switch, 27
 Latches, 32
 LP Fuel light, 21
 Main brush adjustment plate, 18
 Main brush and side brush lever, 14
 Main brush position lever, 17
 Operating/hazard lights switch, 24
 Operation, 12 – 30
 Parking brake lever, 13
 Pressurizer switch, 36
 Side brush down pressure knob, 29
 Side brush position lever, 28
 Steering column tilt lever, 26

Steering wheel, 26
Symbols, 9 - 10
Turn signal switch, 19
Vacuum fan/filter shaker switch, 24
Windshield wiper switch, 35
Controls and Instruments, 11 - 29
Cooling System, Check the coolant level in the reservoir, 72
Covers
 Engine, Latch, 32
 Hopper, Latch, 32
Crankcase ventilation system, 76

D

Debris hopper, 78 - 80
 Dust filter and seals, 37
Dimensions, 97
Directional pedal, 12
Disengaging hopper support bar, 55 - 56
Dome light switch, 36
Doors
 Brush
 Latch, 32
 Seals, 89
 Skirts, 88
 Cab, Latch, 32
 Engine side, Latch, 32
 Grille, Latch, 32
 Hopper, Seals, 90
 Hopper Inspection, Seal, 91
 Right rear Grille, Latch, 32
Dust Control, Skirts, 89
Dust filter, 78 - 80
 Changing, 73 - 74, 79 - 80
 Cleaning, 78

E

Electrical
 Circuit breakers, 30, 31
 Ignition switch, 27
Electronic fuel injection (EFI), 76
Electronic Pressure Regulator, 75
Emptying the hopper, 47 - 48
Engaging hopper support bar, 53 - 54
Engine, 72 - 74
 Air filter, 73
 Coolant level, 37
 Coolant temperature, Light, 22
 Cooling system, 72
 Cover latch, 32

Crankcase ventilation system, 76
Electronic fuel injection (EFI), 76
Electronic Pressure Regulator, 75
Fan belt, 77
Fuel filter (Gasoline), 74
Fuel filter (LPG), 75
Fuel level, 37, 52
Lubrication, 68
Oil capacity, 68
Oil level, 6, 37, 52
Oil pressure, Light, 21
Service records, 37
Side door latch, 32
Spark Plugs, 76
Specifications, 98
Speed switch, 25
Timing Belt, 76
Valve tappets, 76

Engine oil pressure light, 21
Engine speed switch, 25

F

Fuel filter (Gasoline), 74
Fuel filter (LPG), 75
Fuel level gauge, 23
Fuel tank
 Changing LPG, 38 - 39
 Gasoline, 6
 LPG, 7

G

Gauges, Fuel level, 23
Grease fittings
 Hopper bearings, 69
 Rear wheel support, 68

H

Heater knob (option), 35
Heater valve, 63
High engine temperature light, 22
Hopper, 78 - 80
 Changing dust filter, 73 - 74, 79 - 80
 Clogged filter, Light, 22
 Cover latch, 32
 Disengaging hopper support bar, 55 - 56
 Door lever, 15
 Door light, 20
 Door seals, 90
 Dust filter, 78 - 80
 Engaging hopper support bar, 53 - 54
 Filter cleaning, 78

Filter shaker, 24
 Inspection door seal, 91
 Lift, 16
 Lip skirts, 88
 Seals, 90
 Side skirt, 88
 Support bar, 33
 Temperature, Light, 20
 Thermo-Sentry, 81
 Thermo-sentry, 20
 Filter seals, 91

Hopper door, Operate, 15
 Hopper door lever, 15
 Hopper door light, 20
 Hopper lift lever, 16
 Hopper support bar, 33
 Hopper temperature light, 20
 Horn button, 17
 Hourmeter, 23
 How the machine works, 37
 Hydraulic cooler, Fins, 37, 52
 Hydraulic fluid, 70 - 71
 Hydraulic fluid reservoir, 70
 Hydraulic hoses, 71
 Hydraulics, 70 - 71
 Fluid, 70 - 71
 Fluid filter, 70
 Fluid level, 6, 37, 52, 70
 Hoses, 71
 Propelling motor, 71
 Reservoir, 70
 System specifications, 98

I

Ignition switch, 27

J

Jack points, 96 - 97

K

Knobs
 Heater (option), 35
 Side brush down pressure, 29

L

Latches, 32
 Cab door, 32
 Engine cover, 32
 Engine side door, 32
 Grille doors, 32
 Right rear, 32
 Hopper cover, 32
 Hydraulic cooler, 32
 Main brush doors, 32

Levers

Hopper door, 15
 Hopper lift, 16
 Main brush and side brush, 14
 Main brush position, 17
 Parking brake, 13
 Side brush position, 28
 Steering column tilt, 26

Lights

Charging system, 20
 Check engine, 22
 Clogged filter, 22
 Engine oil pressure, 21
 High engine temperature, 22
 Hopper door, 20
 Hopper temperature, 20
 LP Fuel, 21
 Operating/hazard lights switch, 24

LP tank, Low fuel, Light, 21

LP Fuel light, 21

LPG

Changing the fuel tank, 38 - 39
 Fuel tank, 7

Lubrication, 68

Engine, 68
 Front wheel bearings, 69
 Hopper bearings, 69
 Rear wheel support, 68

M

Machine components, 8

Machine dimensions, 99

Machine jacking, 96 - 97

Machine tie down location, 95

Main brush, 42 - 43, 82 - 85

 Adjust brush taper, 85 - 87

 Bristle length, 82

 Checking brush pattern, 84 - 86

 Door latch, 32

 Door seals, 89

 Door skirts, 88

 Lever, 14

 Main brush adjustment plate, 18

Maintenance, 82
Position, 17
Replacing, 83 – 84

Main brush adjustment plate, 18

Main brush and side brush lever, 14

Main brush position lever, 17

Maintenance, 66 – 87
Intervals, 66 – 67
Recommended, 7

Maintenance chart, 66 – 67

Motors, Propelling, 71

O

Operating/hazard lights switch, 24

Operation, 6 – 54

Operation on inclines, 56

Operator Responsibility, 6

Operator seat, 33, 34

Options, 57 – 64
Air conditioning switch, 35
Blower wand, 62 – 63
Cab door latch, 32
Circuit breakers, 31
Dome light switch, 36
Heater knob, 35
Heater valve, 63
Pressurizer switch, 36
Side brush dust control skirts, 89
Steering column tilt lever, 26
Turn signal switch, 19
Vacuum wand, 57 – 62
Windshield wiper switch, 35

P

Parking brake, 92
Adjustment, 92

Parking brake lever, 13

Pedals
Brake, 13
Directional, 12

Post-operation checklist, 52 – 53

Pre-operation checklist, 37 – 38

Pressurizer switch, 36

Pushing machine, 93

Pushing or towing the machine, 93

Pushing, towing, and transporting machine, 93

R

Radiator, 72
Coolant level, 6, 72
Coolant type, 72
Fins, 37, 52
Flushing system, 72
Hoses, 72

Rear wheel, 92

S

Safety
Disengaging hopper support bar, 55 – 56
Engaging hopper support bar, 53 – 54
Hopper support bar, 33
Labels, 5
Precautions, 3

Seals, 88 – 91
Brush doors, 89
Hopper, 90
Hopper door, 90
Hopper inspection door, 91
Hopper filter seals, 91

Seat, 33, 34
Adjustment, 33, 34
Lift, 33

Service records, 52

Side brush, 43, 86 – 87
Bristle length, 86
Checking brush pattern, 86
Down pressure, 29
Dust skirts, 89
Lever, 14
Position, 28
Replacing, 87

Side brush down pressure knob, 29

Side brush dust control skirts, 89

Side brush guard, 87

Side brush position lever, 28

Skirts, 88 – 89
Brush doors, 88
Hopper Lip, 88
Hopper side, 88
Rear, 89
Side brush dust control, 89

Skirts and seals, 37, 52

Spark plugs, 76

- Specifications, 97 - 99
 - Braking system, 98
 - Hydraulic system, 98
 - Machine capacities, 97
 - Machine dimensions, 97
 - Machine performance, 97
 - Power type, 98
 - Steering, 98
 - Tires, 97
 - Starting the machine, 40 - 41
 - Static drag chain, 77
 - Steering, 37, 52
 - Specifications, 98
 - Steering column tilt lever, 26
 - Steering wheel, 26
 - Stop sweeping, 45
 - Stop the machine, 50 - 51
 - Storing machine, 96
 - Sweeping, 43 - 44
 - Sweeping and brush information, 42 - 43
 - Switches
 - Air conditioning (option), 35
 - Dome light, 36
 - Engine speed, 25
 - Ignition, 27
 - Operating/hazard lights, 24
 - Pressurizer, 36
 - Turn signal, 19
 - Vacuum fan/filter shaker, 24
 - Windshield wiper, 35
- T**
- Thermo-sentry, 81
 - Thermo-sentry, 20
 - Tie down location, 95
 - Timing Belt, 76
 - Tires, 92 - 93
 - Pressure, 92
 - Rear wheel, 92
 - Specifications, 97
 - Towing machine, 93
 - Transporting machine, 93
 - Transporting the machine, 93
 - Travel speed, 97
 - Troubleshooting, 64
 - Turn signal switch, 19
- V**
- Vacuum fan/filter shaker switch, 24
 - Vacuum wand, 57 - 62
 - Valve tappet clearance, 76
- W**
- Windshield wiper switch, 35

