

FLOOR-EQUIPMENT-PARTS.COM

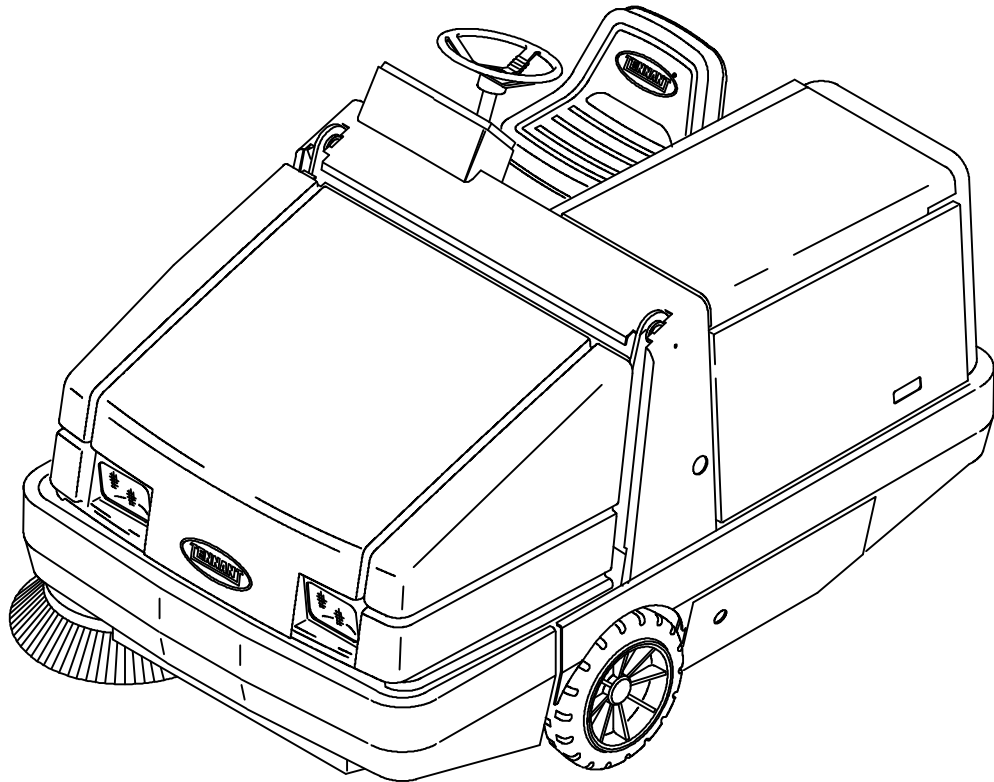

355D

Operator Manual



MM301



This manual is furnished with each new TENNANT Model 355. It provides necessary operating and preventive maintenance instructions. Read this manual completely and understand the machine before operating or servicing it.

This machine will provide excellent service. However, the best results will be obtained at minimum costs if:

- The machine is operated with reasonable care.
- The machine is maintained regularly - per the maintenance instructions provided.
- The machine is maintained with TENNANT supplied or approved parts.

Manual Number - MM301

Revision: 08

Published: 3-97

CONTENTS

	Page		Page
SAFETY PRECAUTIONS	3	HOW THE MACHINE WORKS	30
OPERATION	5	PRE-OPERATION CHECKLIST	30
OPERATOR RESPONSIBILITY	5	STARTING THE MACHINE	32
MACHINE COMPONENTS	7	SWEEPING AND BRUSH INFORMATION	34
CONTROL PANEL SYMBOLS	8	SWEEPING	35
CONTROLS AND INSTRUMENTS	10	STOP SWEEPING	37
OPERATION OF CONTROLS	11	EMPTYING THE HOPPER	38
DIRECTIONAL PEDAL	11	STOP THE MACHINE	40
BRAKE PEDAL	12	POST-OPERATION CHECKLIST	41
PARKING BRAKE LEVER	12	ENGAGING HOPPER SUPPORT BAR ..	42
HORN BUTTON	13	DISENGAGING HOPPER SUPPORT BAR	43
MAIN BRUSH AND SIDE BRUSH		OPERATION ON INCLINES	44
LEVER	13	OPTIONS	45
HOPPER DOOR LEVER	14	VACUUM WAND	45
HOPPER LIFT LEVER	15	BLOWER WAND	51
MAIN BRUSH POSITION LEVER	16	TIE-DOWNS	53
MAIN BRUSH DOWN PRESSURE		HEATER VALVE	54
KNOB	17	MACHINE TROUBLESHOOTING	55
TURN SIGNAL SWITCH (OPTION) ...	17	MAINTENANCE	56
HOPPER TEMPERATURE LIGHT -		MAINTENANCE CHART	56
THERMO SENTRY™	18	LUBRICATION	58
ENGINE WATER TEMPERATURE		ENGINE	58
LIGHT	18	REAR WHEEL SUPPORT	58
ENGINE OIL PRESSURE LIGHT	19	FRONT WHEEL BEARINGS	58
CHARGING SYSTEM LIGHT	19	HYDRAULICS	59
HOPPER DOOR LIGHT	19	HYDRAULIC FLUID RESERVOIR	59
CLOGGED FILTER LIGHT	19	HYDRAULIC FLUID	59
FUEL LEVEL GAUGE	20	HYDRAULIC HOSES	60
HOURMETER	20	PROPELLING MOTOR	60
HAZARD LIGHT SWITCH (OPTION) ..	21	ENGINE	61
OPERATING LIGHTS SWITCH	21	COOLING SYSTEM	61
VACUUM FAN SWITCH	21	AIR FILTER INDICATOR	62
ENGINE SPEED SWITCH	22	AIR FILTER	62
FILTER SHAKER SWITCH	23	FUEL FILTER	63
STEERING WHEEL	23	FUEL PIPES	63
STEERING COLUMN TILT LEVER ...	23	PRIMING FUEL SYSTEM	63
IGNITION SWITCH	24	BATTERY	64
SIDE BRUSH POSITION LEVER	25	BELTS AND CHAINS	64
SIDE BRUSH DOWN PRESSURE		ENGINE FAN BELT	64
KNOB	25	STATIC DRAG CHAIN	64
CIRCUIT BREAKERS	26	DEBRIS HOPPER	65
FUSE	26	HOPPER DUST FILTER	65
LATCHES	27	TO REPLACE HOPPER	
HOPPER SUPPORT BAR	27	DUST FILTER	65
OPERATOR SEAT	28	THERMO SENTRY™	67
WINDSHIELD WIPER			
SWITCH (OPTION)	29		
DOME LIGHT SWITCH (OPTION)	29		
HEATER SWITCH (OPTION)	29		
PRESSURIZER SWITCH (OPTION) ..	29		

CONTENTS

	Page
BRUSHES	67
MAIN BRUSH	67
TO REPLACE MAIN BRUSH	68
TO CHECK AND ADJUST MAIN BRUSH PATTERN	69
SIDE BRUSH	71
TO REPLACE SIDE BRUSH	72
SIDE BRUSH GUARD	72
SKIRTS AND SEALS	73
HOPPER LIP SKIRTS	73
HOPPER SIDE SKIRT	73
BRUSH DOOR SKIRTS	73
REAR SKIRTS	74
SIDE BRUSH DUST CONTROL SKIRTS (OPTION)	74
BRUSH DOOR SEALS	74
HOPPER SEALS	75
HOPPER INSPECTION DOOR SEAL ..	75
HOPPER DOOR SEALS	75
HOPPER COVER SEAL	76
HOPPER DUST SEAL	76
HOPPER VACUUM FAN SEAL	76
BRAKES AND TIRES	77
SERVICE BRAKES	77
PARKING BRAKE	77
TIRES	77
REAR WHEEL	77
PUSHING OR TOWING MACHINE	78
MACHINE JACKING	79
STORING MACHINE	79
SPECIFICATIONS	80
GENERAL MACHINE DIMENSIONS/CAPACITIES	80
GENERAL MACHINE PERFORMANCE ..	80
POWER TYPE	81
STEERING	81
HYDRAULIC SYSTEM	81
BRAKING SYSTEM	81
TIRES	81
INDEX	82

SAFETY PRECAUTIONS

The following precautions are used throughout this manual as indicated in their description:



WARNING: To warn of hazards or unsafe practices which could result in severe personal injury or death.

FOR SAFETY: To identify actions which must be followed for safe operation of equipment.

The machine is suited to sweep disposable debris. Do not use the machine other than described in this Operator Manual. The machine is not designed for use on public roads.

The following information signals potentially dangerous conditions to the operator or equipment:

FOR SAFETY:

1. **Do not operate machine:**
 - Unless trained and authorized.
 - Unless operator manual is read and understood.
 - If it is not in proper operating condition.
 - In flammable or explosive areas unless designed for use in those areas.
 - In areas with possible falling objects unless equipped with overhead guard.
2. **Before starting machine:**
 - Check for fuel, oil, and liquid leaks.
 - Keep sparks and open flame away from refueling area.
 - Make sure all safety devices are in place and operate properly.
 - Check brakes and steering for proper operation.
3. **When starting machine:**
 - Keep foot on brake and directional pedal in neutral.
4. **When using machine:**
 - Use brakes to stop machine.
 - Go slow on inclines and slippery surfaces.
 - Use care when reversing machine.
 - Move machine with care when hopper is raised.
 - Make sure adequate clearance is available before raising hopper.
5. **Before leaving or servicing machine:**
 - Do not carry passengers on machine.
 - Always follow safety and traffic rules.
 - Report machine damage or faulty operation immediately.
 - Stop on level surface.
 - Set parking brake.
 - Turn off machine and remove key.
6. **When servicing machine:**
 - Avoid moving parts. Do not wear loose jackets, shirts, or sleeves.
 - Block machine tires before jacking machine up.
 - Jack machine up at designated locations only. Block machine up with jack stands.
 - Use hoist or jack of adequate capacity to lift machine.
 - Wear eye and ear protection when using pressurized air or water.
 - Disconnect battery connections before working on machine.
 - Avoid contact with battery acid.
 - Avoid contact with hot engine coolant.
 - Allow engine to cool.
 - Keep flames and sparks away from fuel system service area. Keep area well ventilated.
 - Use cardboard to locate leaking hydraulic fluid under pressure.
 - Use TENNANT supplied or approved replacement parts.



WARNING: Engine emits toxic gases. Severe respiratory damage or asphyxiation can result. Provide adequate ventilation. Consult with your regulatory authorities for exposure limits. Keep engine properly tuned.



WARNING: Raised hopper may fall. Engage hopper support bar.



WARNING: Lift arm pinch point. Stay clear of hopper lift arms.



WARNING: Moving belt and fan. Keep away.

CALIFORNIA PROPOSITION 65
WARNING: Engine exhaust from this product contains chemicals known to the State of California to cause cancer, birth defects, or other reproductive harm.

SAFETY PRECAUTIONS

The following safety labels are mounted on the machine in the locations indicated. If these or any label becomes damaged or illegible, install a new label in its place.

EMISSIONS LABEL - LOCATED ON THE SIDE PANEL OF THE OPERATOR COMPARTMENT.



ENGINE FAN AND BELT LABEL - LOCATED ON THE RADIATOR SHROUD.



FOR SAFETY LABEL - LOCATED ON THE SIDE PANEL OF THE OPERATOR COMPARTMENT.

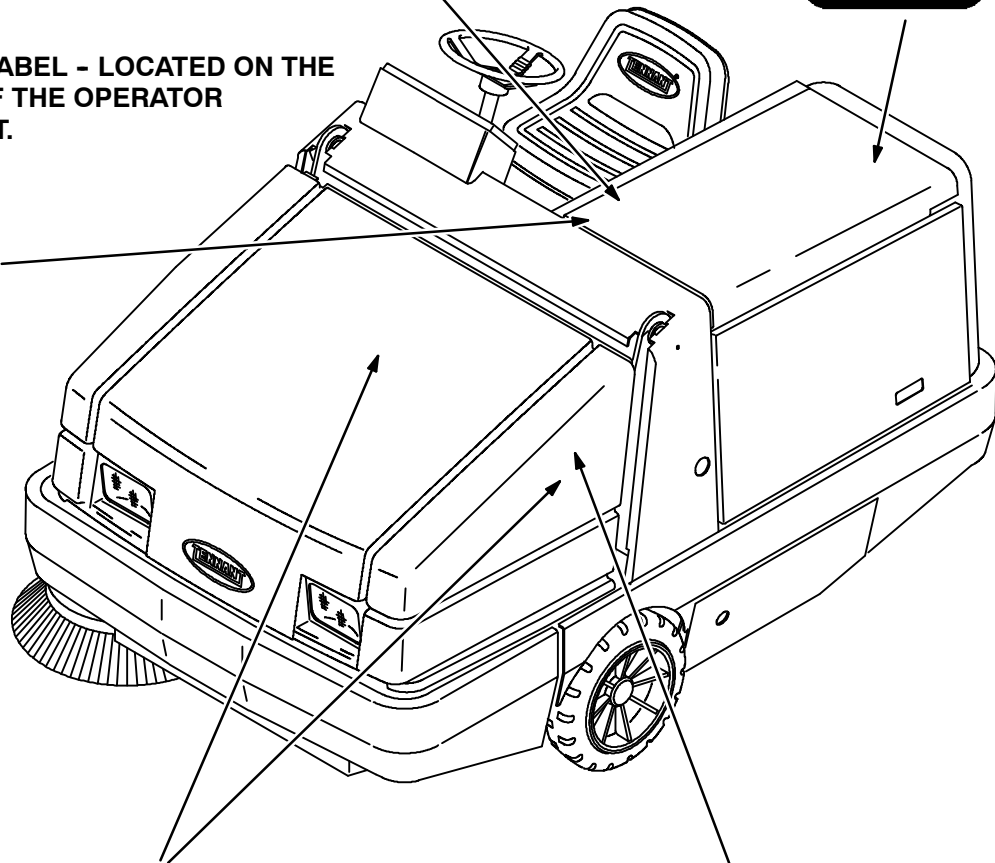
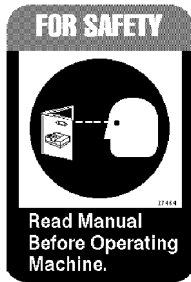

07748

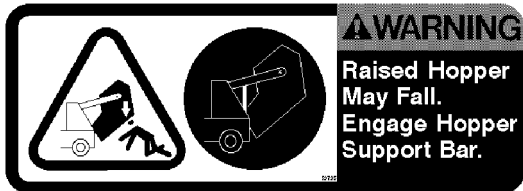

HOPPER SUPPORT BAR LABEL - LOCATED ON THE HOPPER SUPPORT BAR AND ON BOTH HOPPER LIFT ARMS.



HOPPER LIFT ARMS LABEL - LOCATED ON BOTH HOPPER LIFT ARMS.

OPERATION

OPERATOR RESPONSIBILITY

- The operator's responsibility is to take care of the daily maintenance and checkups of the machine to keep it in good working condition. The operator must inform the service mechanic or supervisor when the required maintenance intervals occur as stated in the *MAINTENANCE* section of this manual.
- Read this manual carefully before operating this machine.

FOR SAFETY: Do not operate machine, unless operation manual is read and understood.

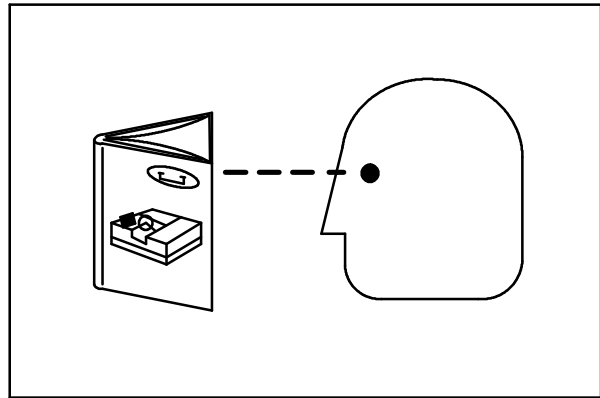

07324

- Check the machine for shipping damage. Check to make sure machine is complete per shipping instructions.
- Check the hydraulic fluid level in the hydraulic reservoir.

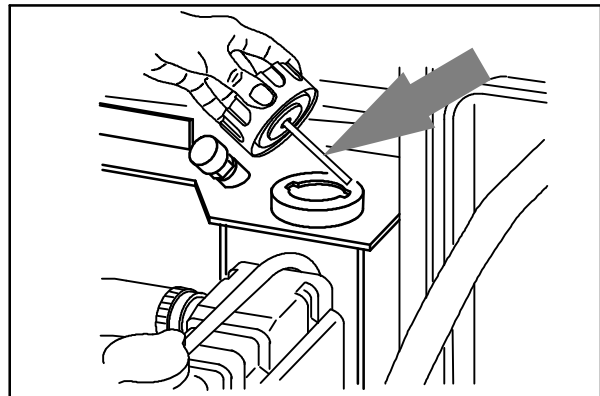

07750

- Check the engine oil level.

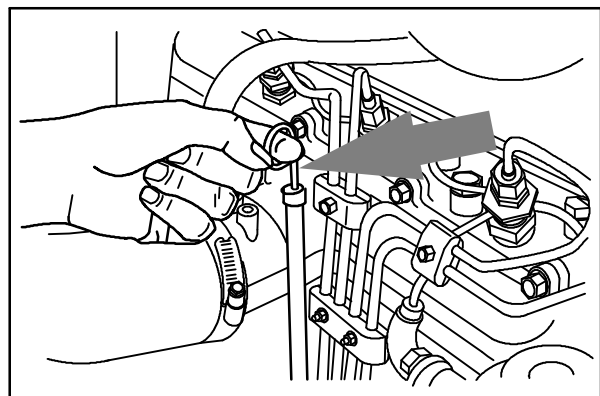

08431

OPERATION

- Check the radiator coolant level.

FOR SAFETY: When servicing machine, avoid contact with hot engine coolant.

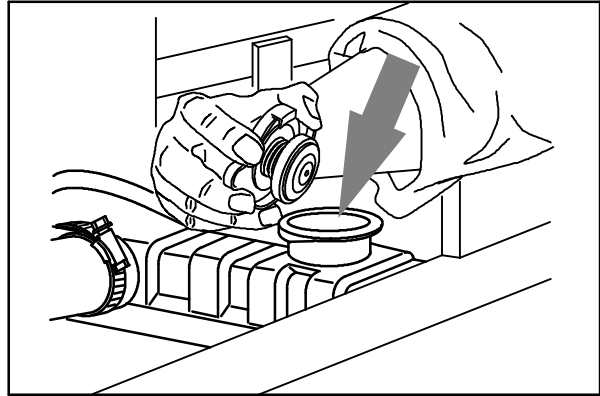

07752

- Fill the fuel tank.

FOR SAFETY: When servicing machine, keep flames and sparks away from fuel system service area. Keep area well ventilated.

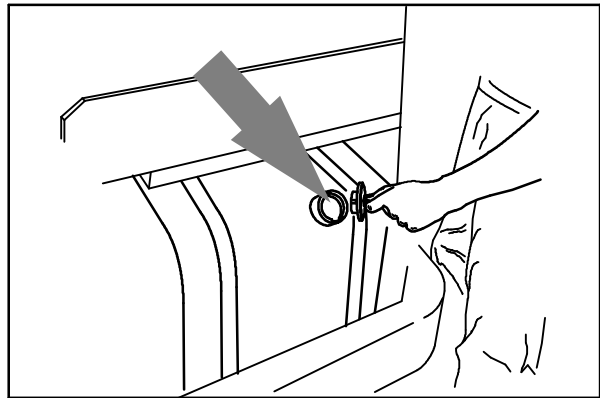

07753

- After the first 50 hours of operation, follow the recommended procedures stated in the *MAINTENANCE CHART*.
- Keep your machine regularly maintained by following the maintenance information in this manual. We recommend taking advantage of a regularly scheduled service contract from your TENNANT representative.
- Order parts and supplies directly from your authorized TENNANT representative. Use the parts manual provided when ordering parts.

MACHINE COMPONENTS

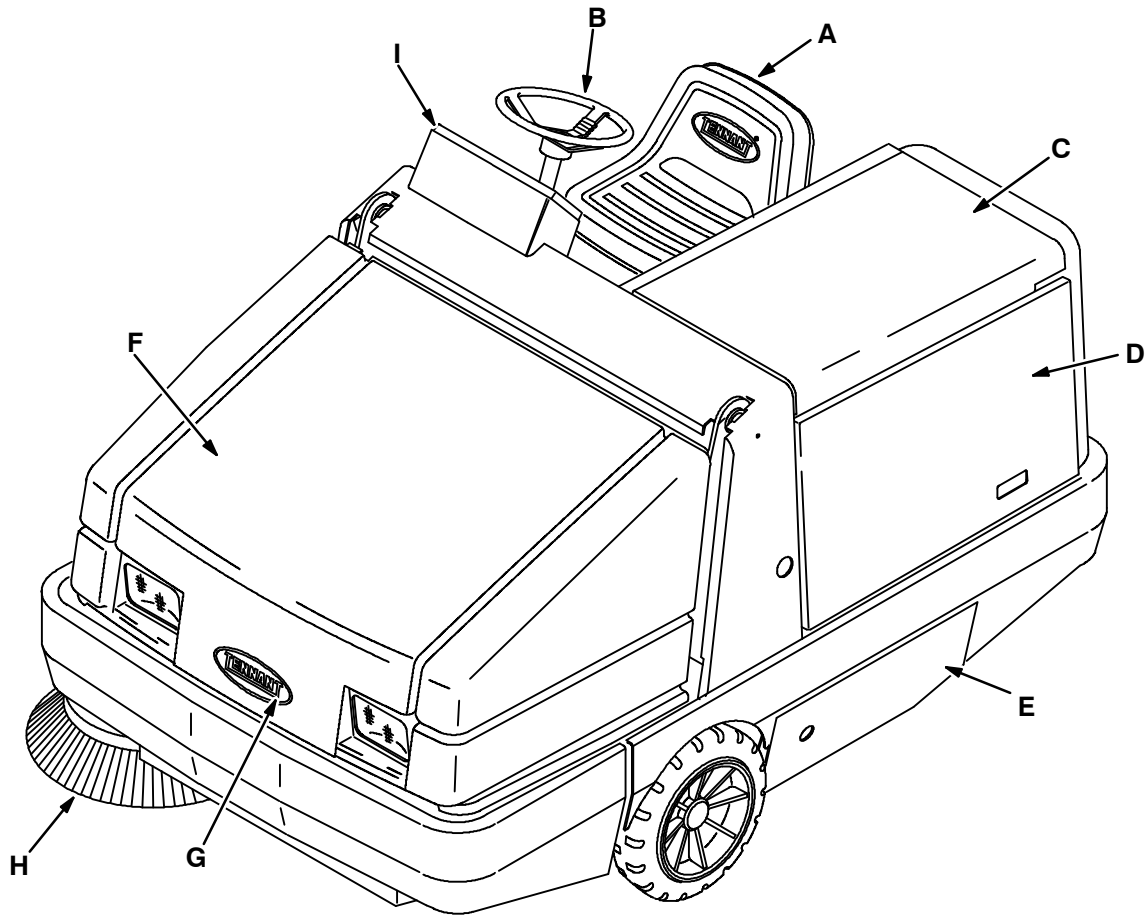

- | | |
|---------------------------|------------------------|
| A. Operator Seat | F. Hopper Cover |
| B. Steering Wheel | G. Hopper Access Cover |
| C. Engine Cover | H. Side Brush |
| D. Engine Side Door | I. Instrument Panel |
| E. Main Brush Access Door | |

07748

OPERATION

CONTROL PANEL SYMBOLS

These symbols identify controls and displays on the machine:



Main and Side Brushes On



Charging System



Main Brush On



Engine Oil Pressure



Hopper Door Open



Engine Water Temperature



Hopper Door Close



Hopper Temperature - Thermo Sentry™



Hopper Down



Filter Clogged



Hopper Up



Hopper Door Closed



Horn



Fuel



Main Brush Down Pressure Light



Hourmeter



Main Brush Down Pressure Heavy



Hazard Light



Main Brush Float



Filter Shaker



Main Brush Down



Operating Lights



Main Brush Up



Fan



Side Brush Down Pressure Light



Engine Speed



Side Brush Down Pressure Heavy



Side Brush Down



Side Brush Up



Circuit Breaker 1



Circuit Breaker 2



Circuit Breaker 3



Circuit Breaker 4



Circuit Breaker 5



Circuit Breaker 6



Circuit Breaker 7



Circuit Breaker 8



Circuit Breaker 9



Circuit Breaker 10



Windshield Wiper Slow



Windshield Wiper Fast



Dome Light



Heater



Cab Pressurizer Slow



Cab Pressurizer Fast

OPERATION

CONTROLS AND INSTRUMENTS

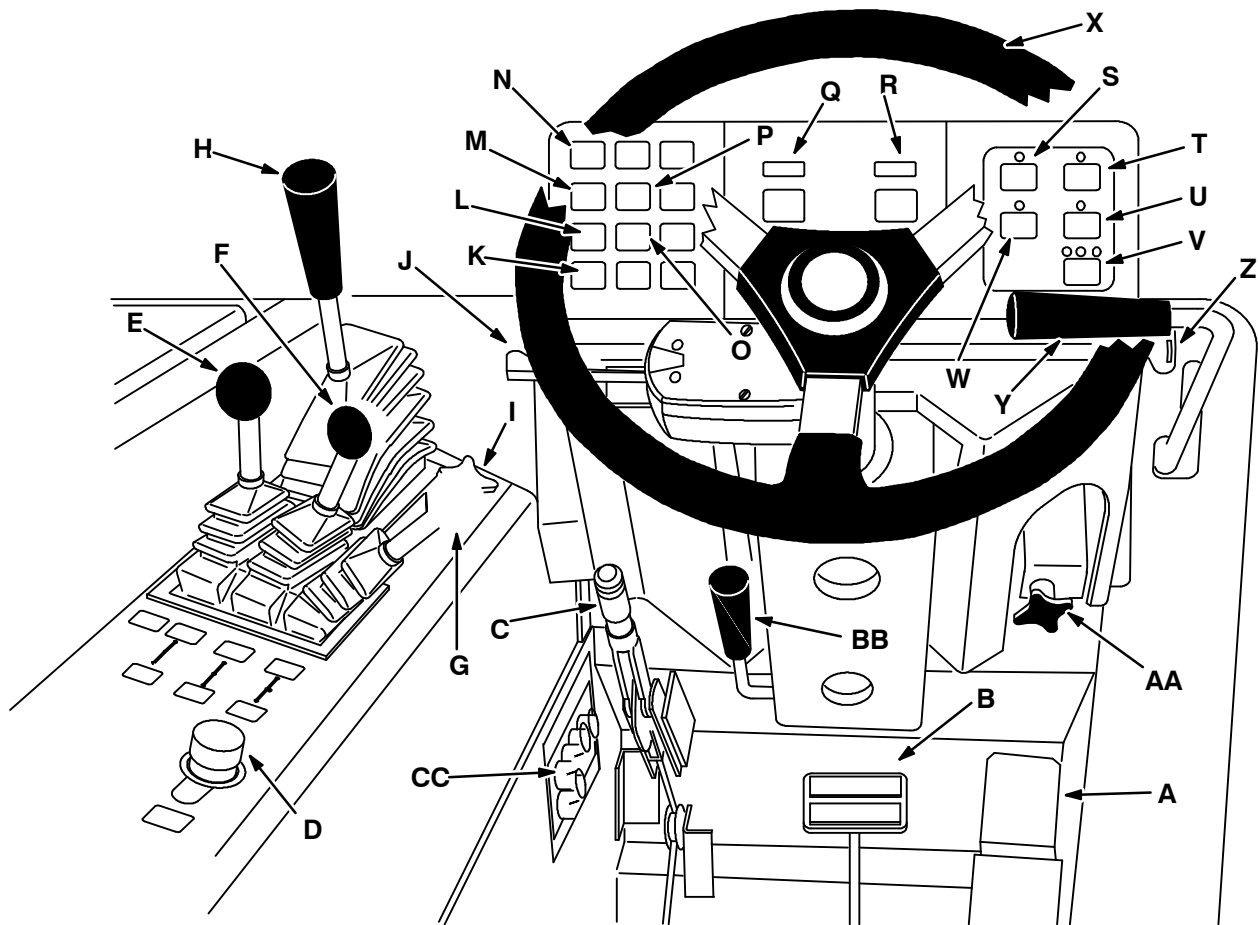

07789

- | | |
|---|-----------------------------------|
| A. Directional Pedal | O. Hopper Door Light |
| B. Brake Pedal | P. Clogged Filter Light |
| C. Parking Brake Lever | Q. Fuel Level Gauge |
| D. Horn Button | R. Hourmeter |
| E. Main Brush And Side Brush Lever | S. Hazard Light Switch (Option) |
| F. Hopper Door Lever | T. Operating Light Switch |
| G. Hopper Lift Lever | U. Vacuum Fan Switch |
| H. Main Brush Position Lever | V. Engine Speed Switch |
| I. Main Brush Down Pressure Knob | W. Filter Shaker Switch |
| J. Turn Signal Switch (Option) | X. Steering Wheel |
| K. Hopper Temperature Light –
Thermo Sentry™ | Y. Side Brush Position Lever |
| L. Engine Water Temperature Light | Z. Ignition Switch |
| M. Engine Oil Pressure Light | AA. Side Brush Down Pressure Knob |
| N. Charging System Light | BB. Steering Column Tilt Lever |
| | CC. Circuit Breakers |

OPERATION OF CONTROLS

DIRECTIONAL PEDAL

The directional pedal controls direction of travel and the propelling speed of the machine. You change the speed of the machine with the pressure of your foot; the harder you press the faster the machine travels.

Forward: Press the top of the directional pedal with the toe of your foot.

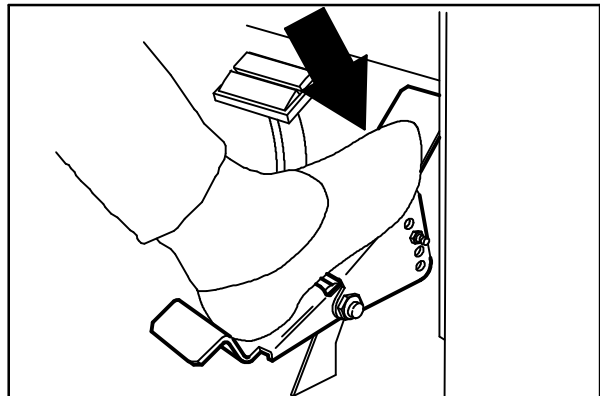

07790

Reverse: Press the bottom of the directional pedal with the heel of your foot.

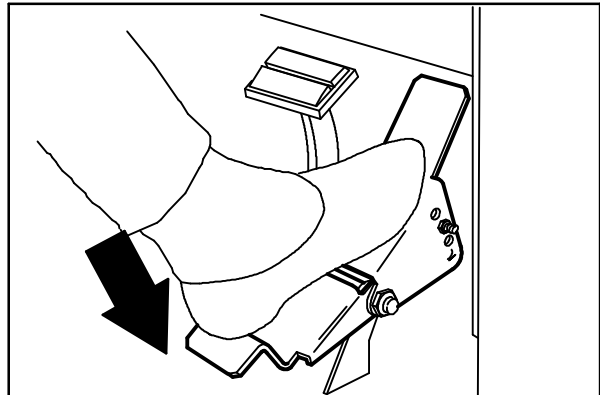

07791

Neutral: Take your foot off the directional pedal and it will return to the neutral position.

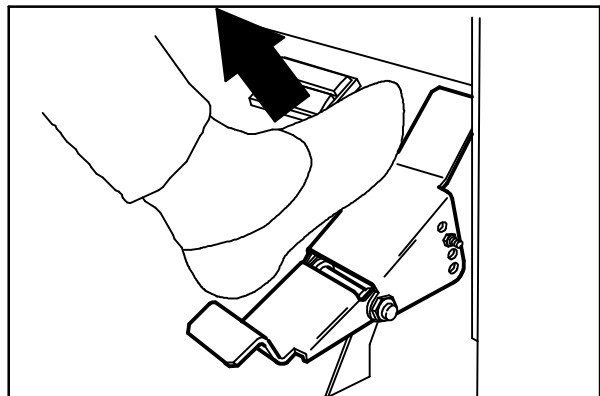

07792

OPERATION

BRAKE PEDAL

The brake pedal stops the machine.

Stop: Take your foot off the directional pedal and let it return to the neutral position. Step on the brake pedal.

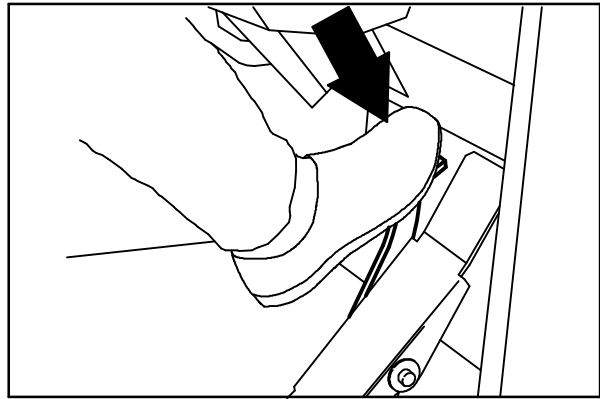

07754

PARKING BRAKE LEVER

The parking brake lever sets and releases the front wheel brakes.

Set: Pull the parking brake lever up.

FOR SAFETY: Before leaving or servicing machine; stop on level surface, set parking brake, turn off machine and remove key.

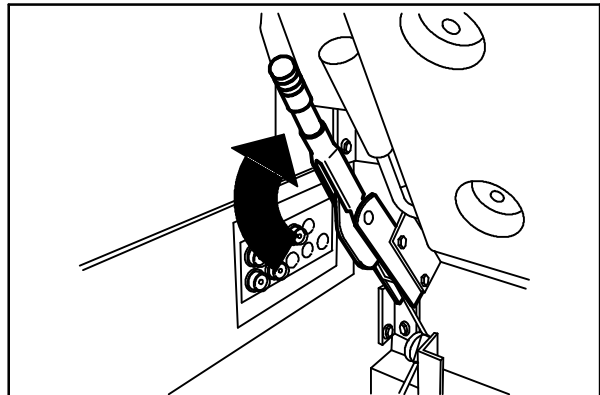

07794

Release: Push the parking brake lever down.

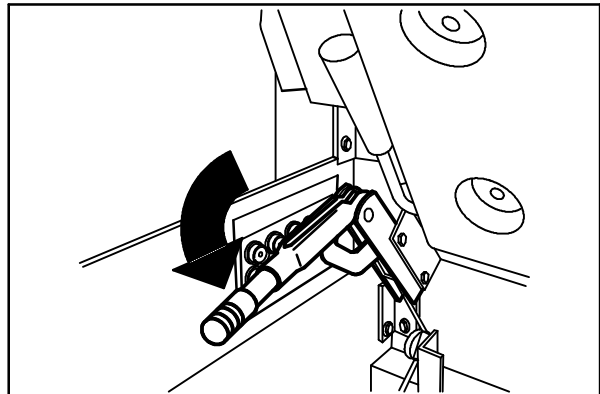

07793

HORN BUTTON

The horn button operates the horn.

Sound: Press the button.

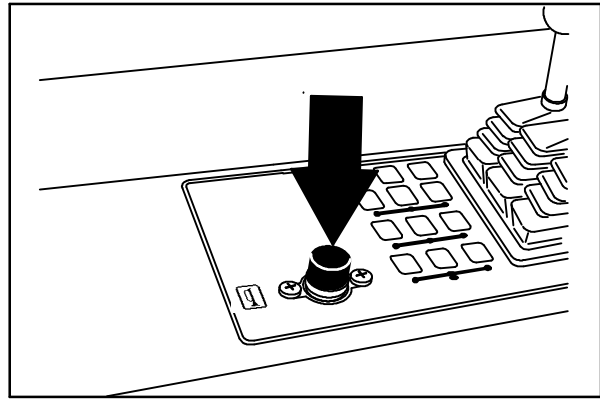

08032

MAIN BRUSH AND SIDE BRUSH LEVER

The main brush and side brush lever controls the main brush and side brush rotation.

Main Brush and Side Brush On: Push the main brush and side brush lever into the **On** position.

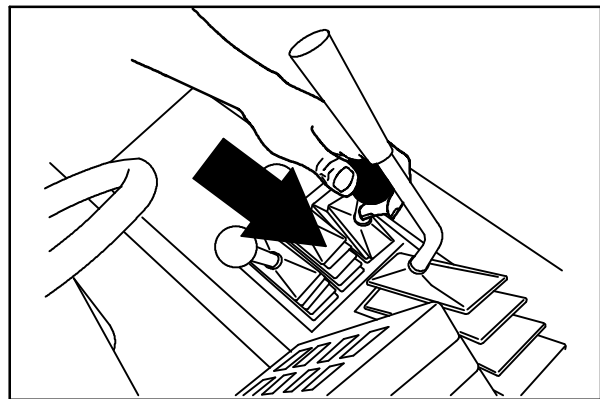

07773

Main Brush and Side Brush Off: Pull the main brush and side brush lever into the middle position.

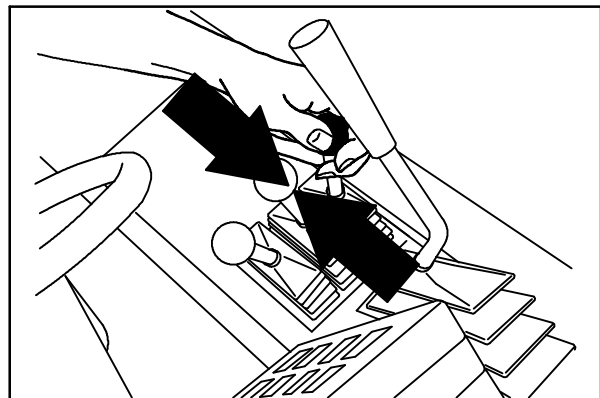

07774

Main Brush On: Pull the main brush and side brush lever into the **On** position.

NOTE: Always raise the main brush when the machine is not being operated for some time. This prevents the main brush from getting a flat spot.

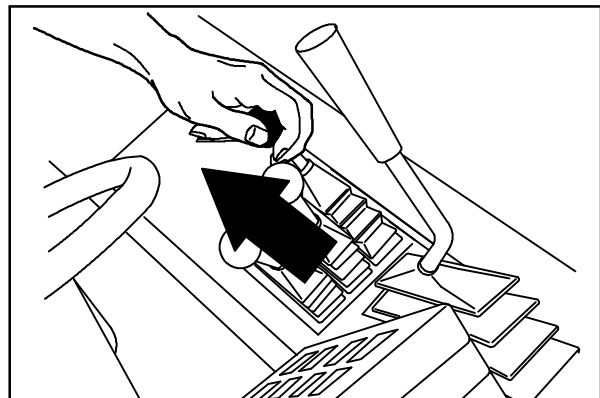

07775

OPERATION

HOPPER DOOR LEVER

The hopper door lever opens and closes the hopper door and dust door. Open the hopper door when sweeping. Close the hopper door when emptying the hopper to control debris and dust.

Open: Push the hopper door lever into the **Open** position and leave it there.

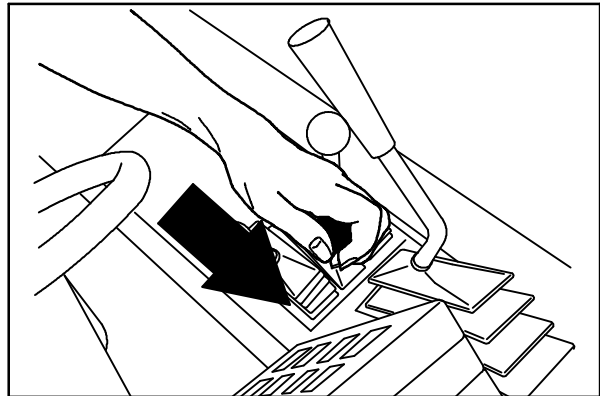

07776

Hold: Release the hopper door lever into the middle position.

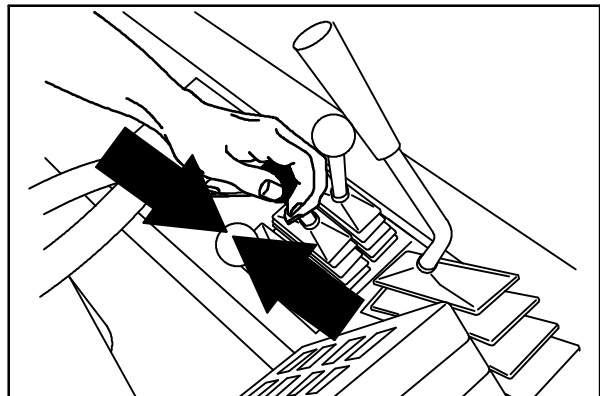

07777

Close: Pull and hold the hopper door lever into the **Close** position.

NOTE: The hopper door will not close if the main brush, side brush, and vacuum fan are operating.

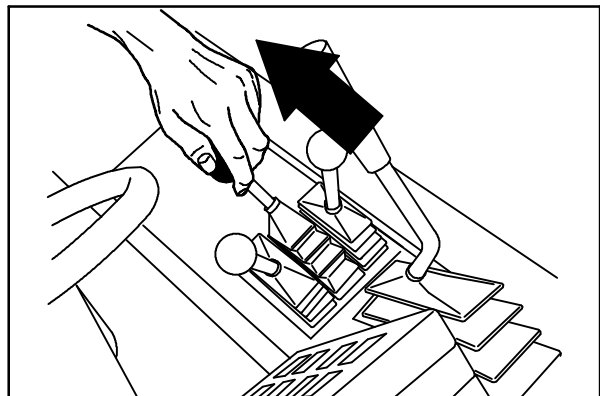

07778

HOPPER LIFT LEVER

The hopper lift lever raises and lowers the hopper.

Up: Pull and hold the hopper lift lever into the **Up** position.

 **WARNING: Raised hopper may fall.
Engage hopper support bar.**

NOTE: The hopper will not raise if the main brush, side brush, and vacuum fan are operating.

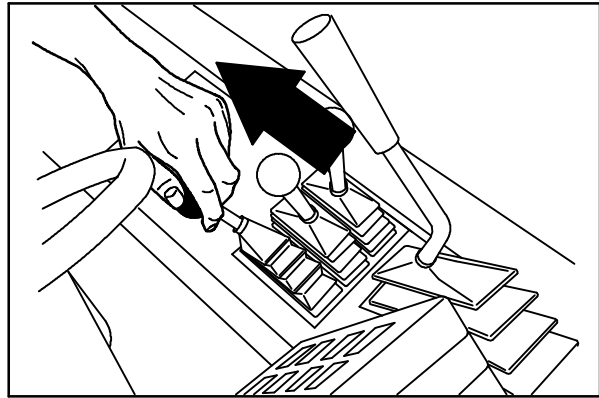

07779

Hold: Release the hopper lift lever up and into the middle position.

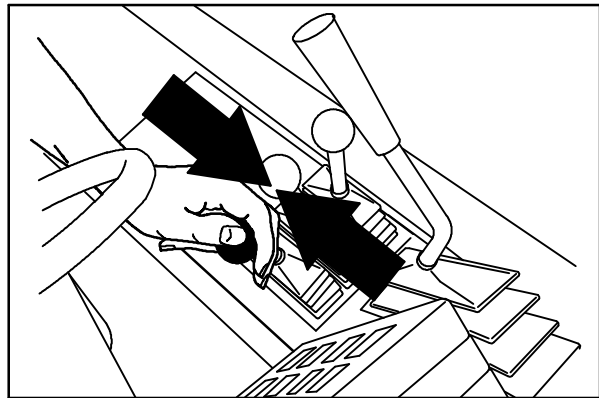

07780

Down: Push and hold the hopper lift lever into the **Down** position.

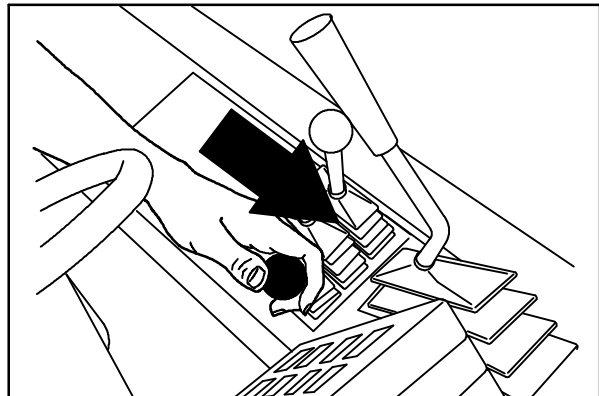

07781

OPERATION

MAIN BRUSH POSITION LEVER

The main brush position lever lowers and raises the main brush. The main brush can be lowered into two sweeping positions; down and float. Down is used for general sweeping. Float is used when sweeping extremely uneven surfaces.

Down: Pull the main brush position lever back and to the left into the **Down** position.

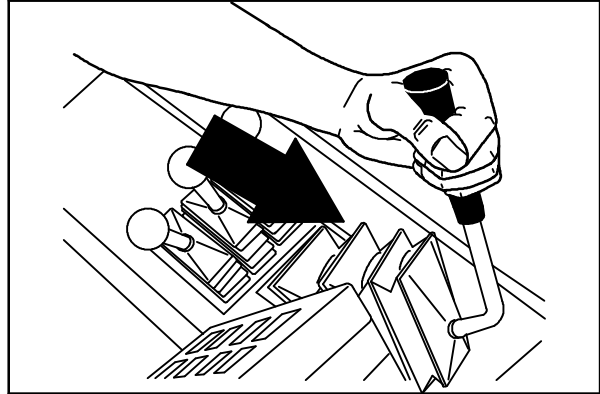

07782

Float: Pull the main brush position lever back and to the left and over into the **Float** position.

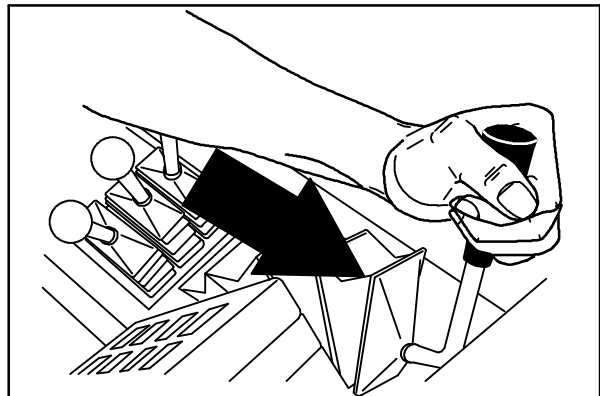

07783

Up: Pull the main brush position lever all the way back and to the right into the **Up** position.

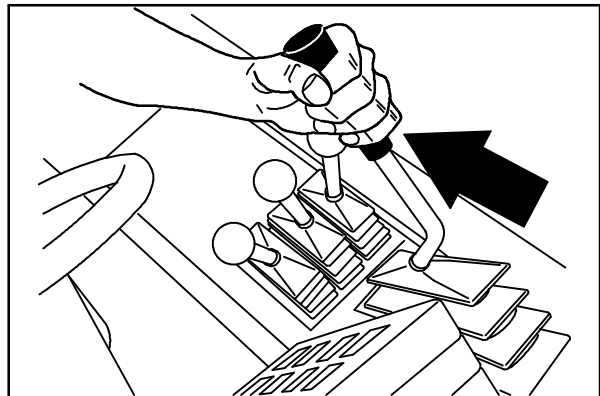

07784

MAIN BRUSH DOWN PRESSURE KNOB

The main brush down pressure knob changes the main brush contact with the sweeping surface.

Heavy: Turn the main brush down pressure knob counter-clockwise.

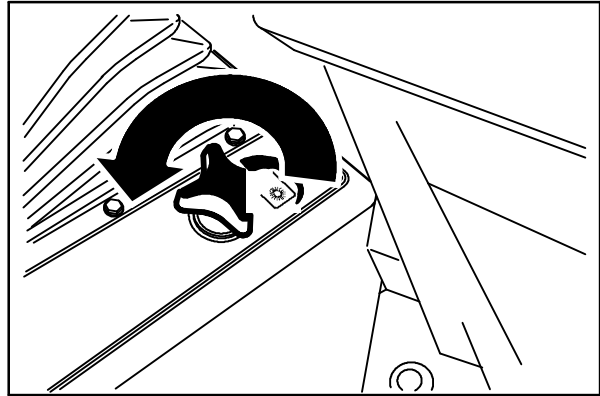

07787

Light: Turn the main brush down pressure knob clockwise.

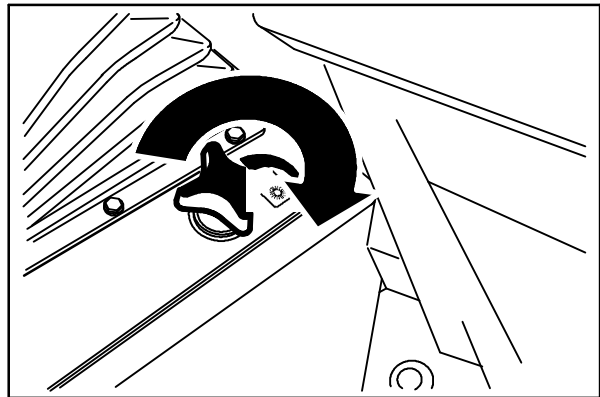

07788

TURN SIGNAL SWITCH (OPTION)

The turn signal switch operates the turn signals.

Right: Push the switch lever forward.

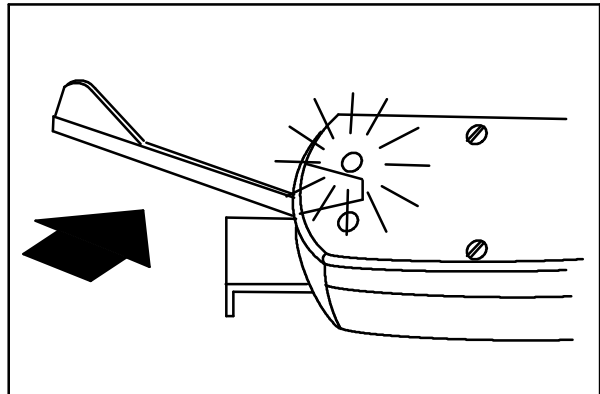

06487

OPERATION

Left: Pull the switch lever back.

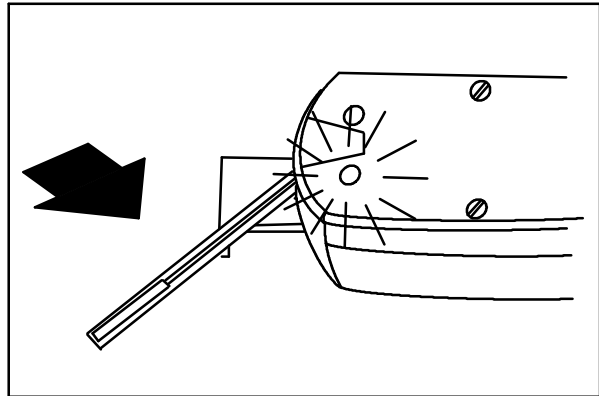

06488

Flashers: Pull out the knob.

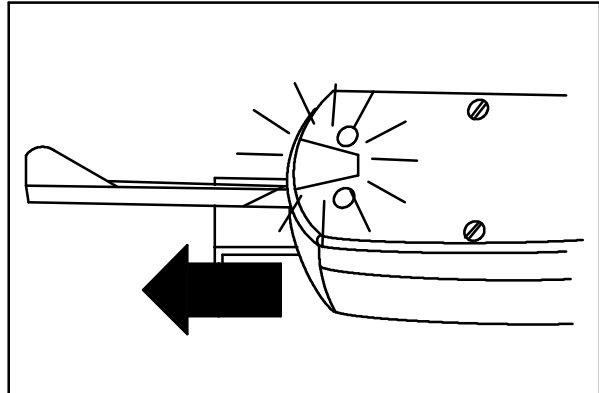

06745

HOPPER TEMPERATURE LIGHT - THERMO SENTRY™

The hopper temperature light comes on when there is too much heat in the hopper, possibly from a fire. The Thermo Sentry will stop the vacuum fan.

The Thermo Sentry™ has to be reset manually, see *THERMO SENTRY* in *MAINTENANCE*.

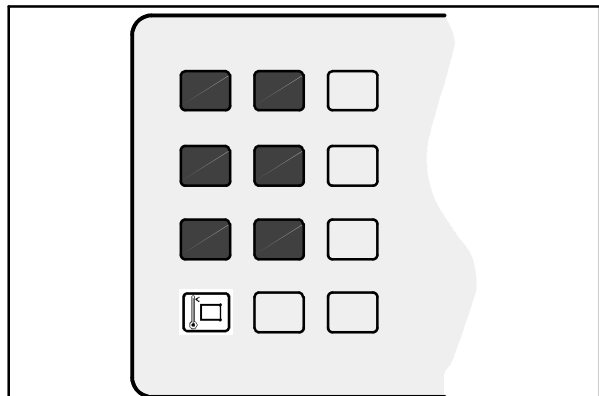

07760

ENGINE WATER TEMPERATURE LIGHT

The engine water temperature light comes on when the temperature of the engine coolant is more than 107° C (225° F). Stop operating the machine. Locate the problem and have it corrected.

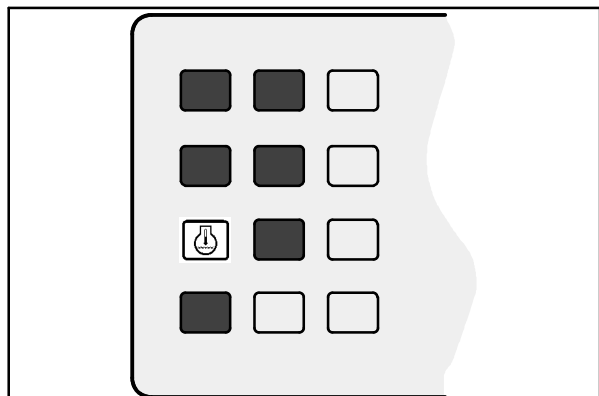

07759

ENGINE OIL PRESSURE LIGHT

The engine oil pressure light comes on when the engine oil pressure falls below 35 kPa (5 psi). Stop operating the machine. Locate the problem and have it corrected.

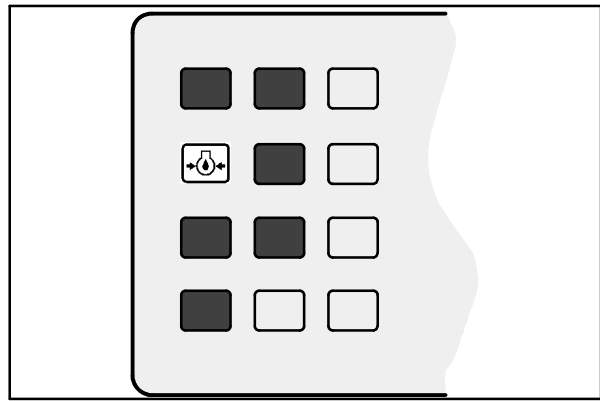

07758

CHARGING SYSTEM LIGHT

The charging system light comes on when the existing voltage potential of the battery is not within normal range - 10 to 14 Volts. Stop operating the machine. Locate the problem and have it corrected.

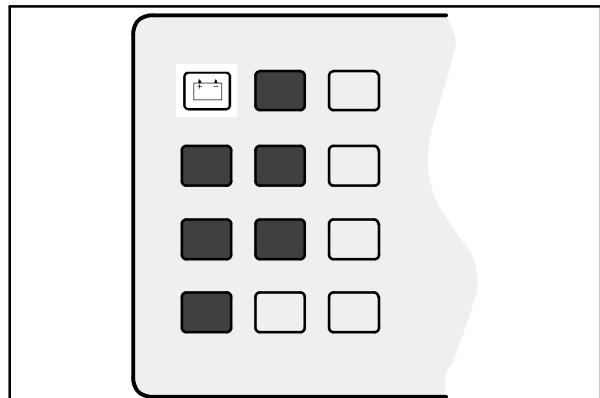

07757

HOPPER DOOR LIGHT

The hopper door light comes on when the hopper door is closed. Make sure the hopper door is open and the hopper door light is off, before sweeping with the machine.

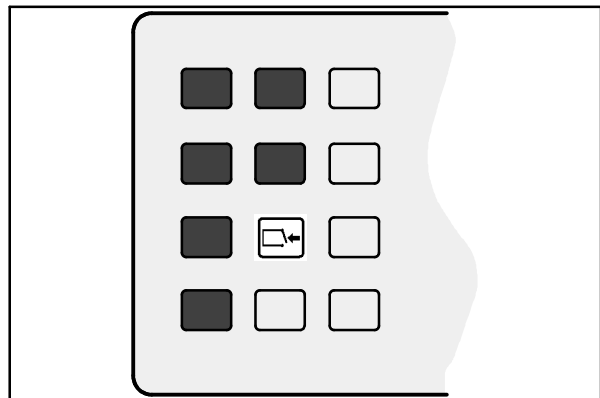

07763

CLOGGED FILTER LIGHT

The clogged filter light comes on when the hopper dust filter is clogged.

To clean the filter, press the filter shaker switch. If the clogged filter light remains lit, manually clean the hopper dust filter. See *HOPPER DUST FILTER* in *MAINTENANCE*.

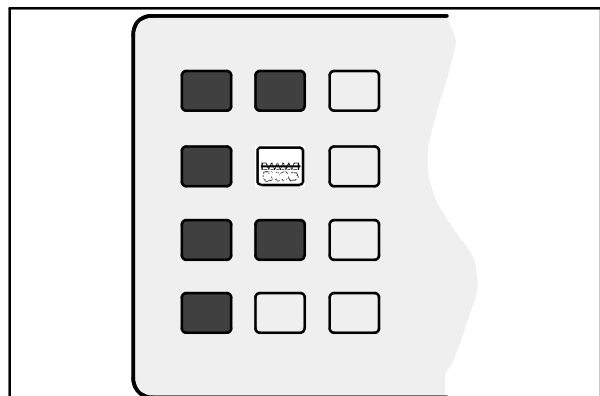

07762

OPERATION

FUEL LEVEL GAUGE

The fuel level gauge indicates how much fuel is in the fuel tank with a segmented LED light. When the tank is full, all ten of the segments are lit. As the fuel tank empties, the segments shut off. The fuel tank is empty when all ten of the segments have shut off.

NOTE: Do not let the fuel tank empty completely. Air can enter the fuel system. The fuel system will need bleeding before the next engine start.

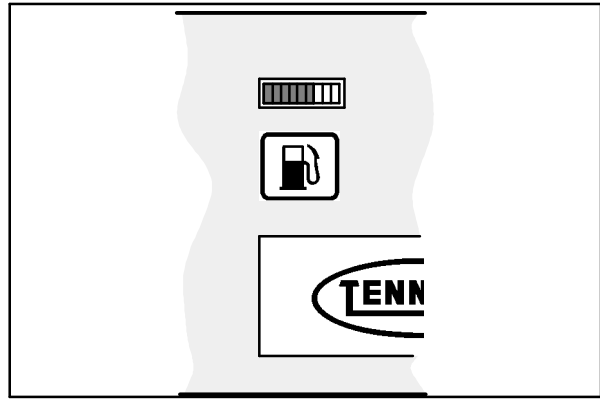

07764

HOURLMETER

The hourmeter records the number of hours the machine has been operated. Use this information to determine machine maintenance intervals.

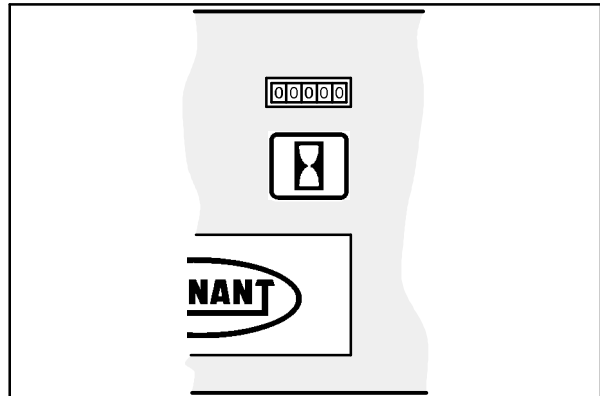

07765

HAZARD LIGHT SWITCH (OPTION)

The hazard light switch powers on and off the hazard light.

On: Press the hazard light switch. The indicator light above the switch will come on.

Off: Press the hazard light switch. The indicator light above the switch will go off.

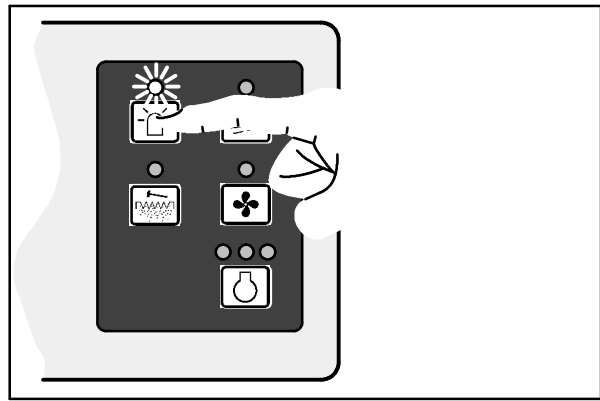

07766

OPERATING LIGHTS SWITCH

The operating lights switch powers on and off the headlights and taillights.

On: Press the operating lights switch. The indicator light above the switch will come on.

Off: Press the operating lights switch. The indicator light above the switch will go off.

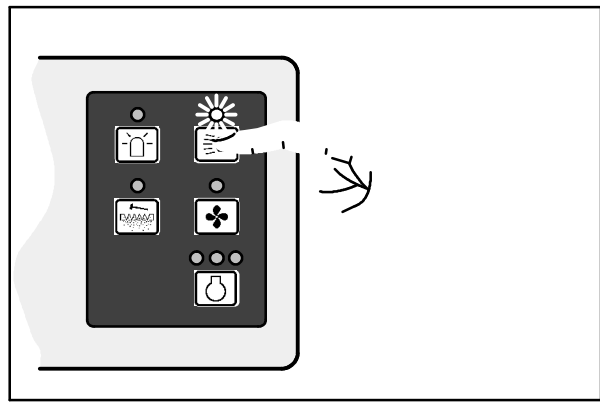

07768

VACUUM FAN SWITCH

The vacuum fan switch starts and stops the vacuum fan.

Start: Press the vacuum fan switch. The indicator light above the switch will come on.

Stop: Press the vacuum fan switch. The indicator light above the switch will go off.

NOTE: The vacuum fan will not operate unless the main brush and side brush are on.

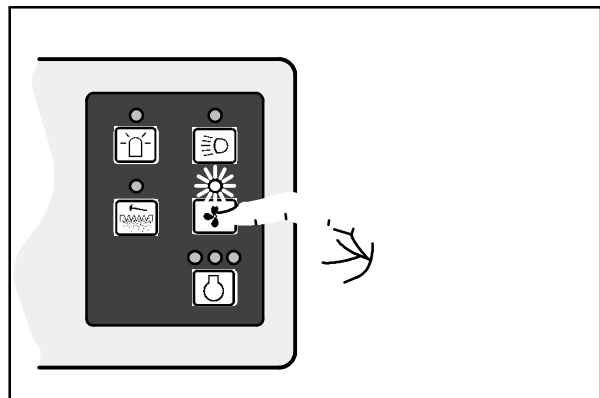

07769

OPERATION

ENGINE SPEED SWITCH

The engine speed switch controls engine governed speed. The three indicator lights above the switch show the engine speed; Idle, Fast1, or Fast2.

Idle: The engine will automatically start in idle speed. To return the engine to idle from another engine speed, press the engine speed switch until the first indicator light comes on.

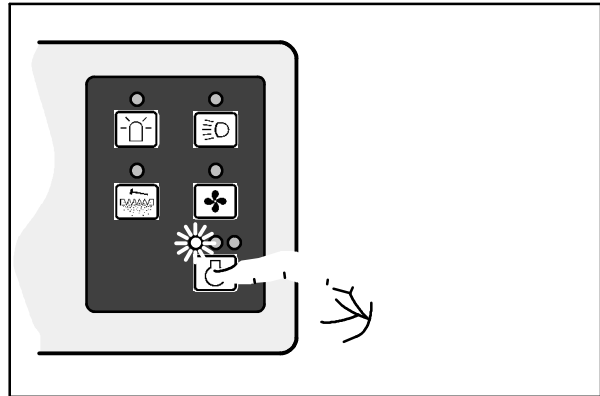

07770

Fast 1: Press the engine speed switch until the second indicator light comes on. This speed is for general sweeping.

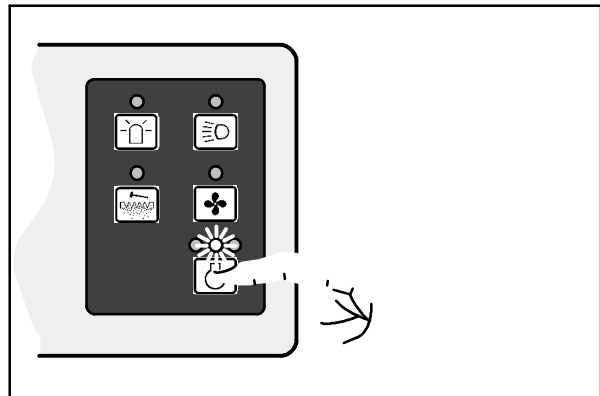

07771

Fast 2: Press the engine speed switch until the third indicator light comes on. This speed is for sweeping light litter.

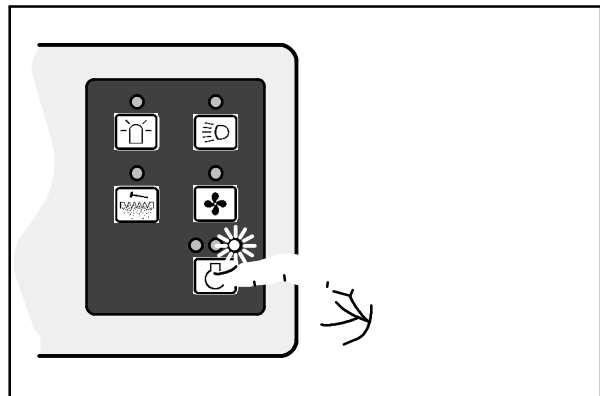

07772

FILTER SHAKER SWITCH

The filter shaker switch starts the hopper dust filter shaker. The shaker automatically operates for 40 seconds.

Start: Press the filter shaker switch. The indicator light will remain on while the filter shaker is operating.

NOTE: The vacuum fan shuts off while the filter shaker is operating.

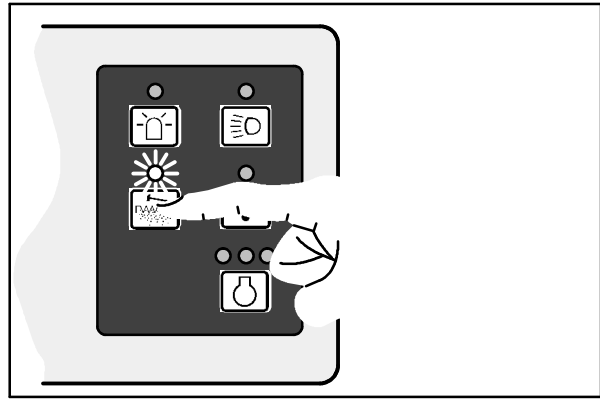

07767

STEERING WHEEL

The steering wheel controls the machine's direction. The machine is very responsive to the steering wheel movements.

Left: Turn the steering wheel to the left.

Right: Turn the steering wheel to the right.

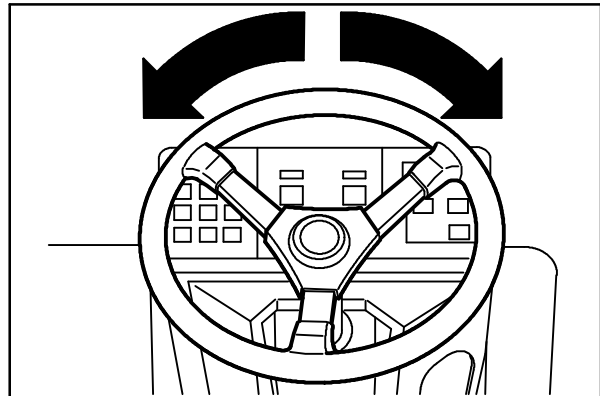

07801

STEERING COLUMN TILT LEVER

The steering column tilt lever controls the angle of the steering column.

Adjust: Pull down on the tilt lever, move the column up or down, and release the tilt lever.

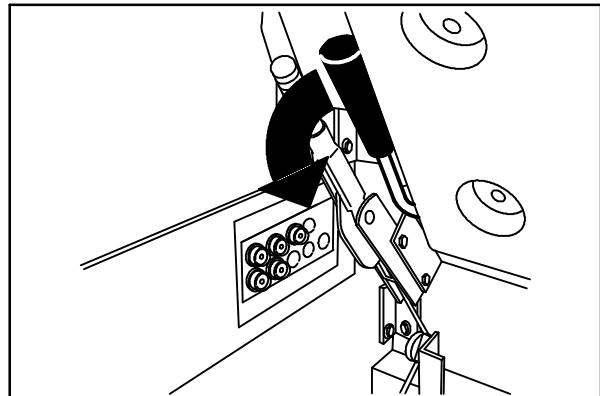

07802

OPERATION

IGNITION SWITCH

The ignition switch starts and stops the engine with a key.

For Safety: When starting machine, keep foot on brake and directional pedal in neutral.

Preheat: Turn the key all the way counter-clockwise and hold it there for 15 to 60 seconds, depending on the weather conditions.

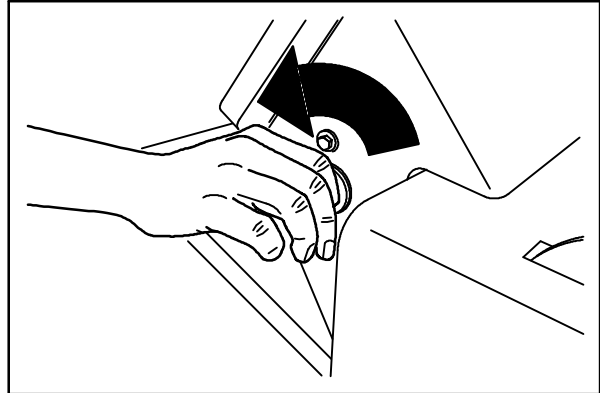

07805

Start: Turn the key all the way clockwise. Release the key as soon as the engine starts.

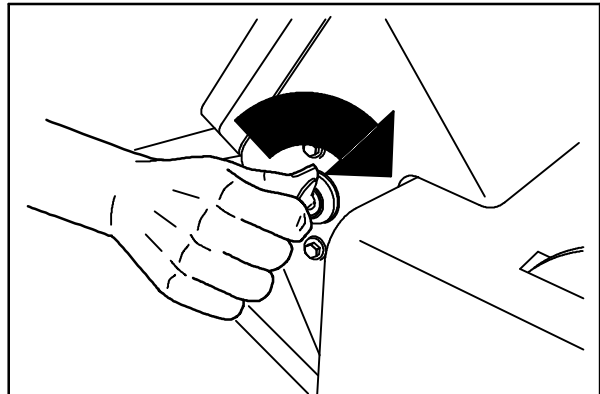

07804

Stop: Turn the key counter-clockwise.

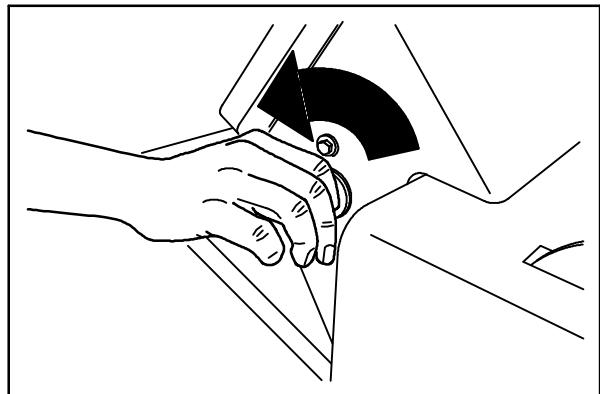

07805

SIDE BRUSH POSITION LEVER

The side brush position lever lowers and raises the side brush.

Down: Pull the side brush position lever back and to the right into the **Down** slot.

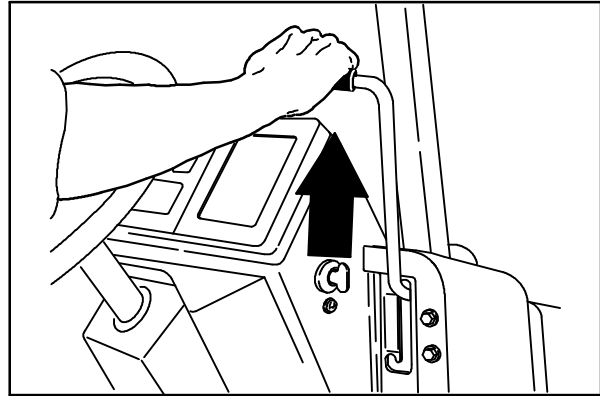

07785

Up: Pull the side brush position lever back and to the left into the **Up** slot.

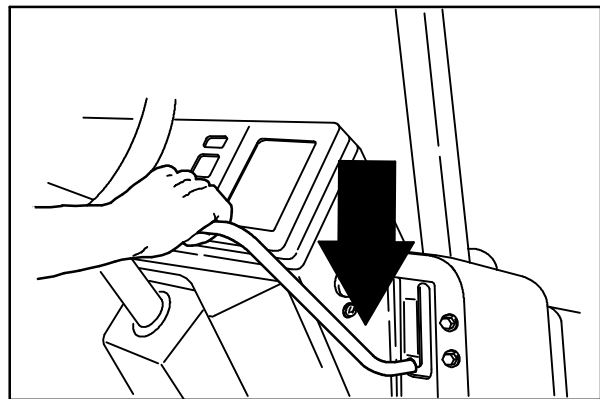

07786

SIDE BRUSH DOWN PRESSURE KNOB

The side brush down pressure knob changes the side brush contact with the sweeping surface.

Heavy: Turn the side brush down pressure knob counter-clockwise.



07799

Light: Turn the side brush down pressure knob clockwise.



07800

OPERATION

CIRCUIT BREAKERS

The circuit breakers are resettable electrical circuit protection devices. Their design stops the flow of current in the event of a circuit overload. Once a circuit breaker is tripped, it must be reset manually. Press the reset button after the breaker has cooled down.

If the overload that caused the circuit breaker to trip is still there, the circuit breaker will continue to stop current flow until the problem is corrected.

The circuit breakers are located in the operator compartment.

The chart lists the circuit breakers and the electrical components they protect.

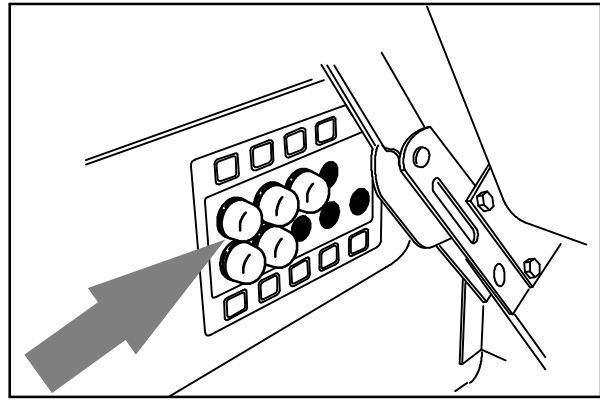

07806

Circuit Breaker	Rating	Circuit Protected
CB-1	15 A	Engine and throttle
CB-2	15 A	Vacuum fan, filter shaker
CB-3	15 A	Operating lights
CB-4	15 A	Hazard light, back-up alarm
CB-5	15 A	Horn
CB-6	2.5 A	Instrument panel
CB-7	15 A	Heater/defrost, windshield wiper
CB-8	15 A	Turn Signals
CB-9	15 A	Auxiliary side brush
CB-10	15 A	Cab Pressurizer

FUSE

Fuses are a one-time protection device designed to stop the flow of current in the event of a circuit overload. Never substitute higher value fuses than specified.

The fuse is located in the operator compartment under the steering column.

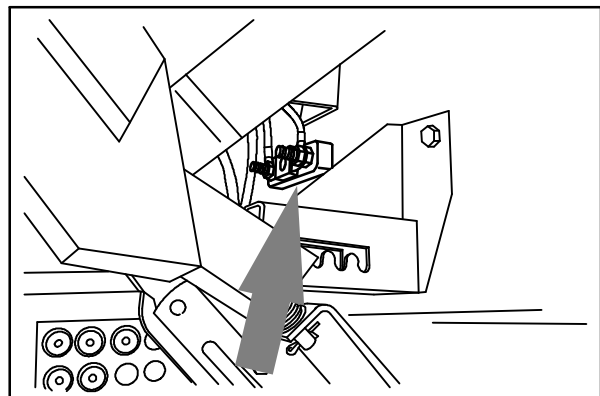

08033

Fuse	Rating	Circuit Protected
FU-1	40 A	Glow plugs

LATCHES

The side doors, rear doors, engine cover, hopper cover, and cab door are secured with latches.

Open the Main Brush Side Doors: Push down on the door latch.

Open the Engine Side Door: Pull up on the door latch.

Open the Grille Doors: Push down on the door latch.

Open the Engine Cover: Push in on the cover latch.

Open the Hopper Cover: Push the cover latch to the right and pull up on the hopper cover.

Open the Cab Door: Pull up on the door handle.

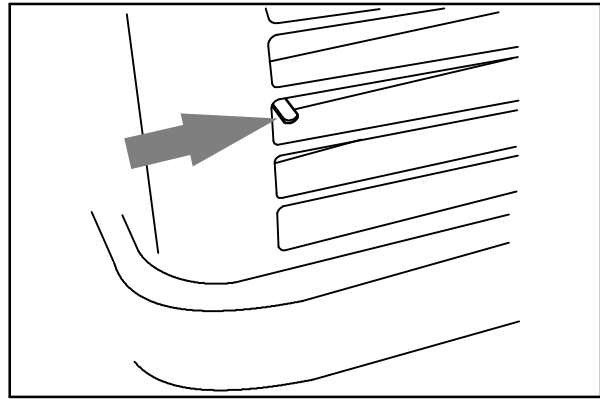

08149

HOPPER SUPPORT BAR

The hopper support bar is located on the operator's side of the hopper. The hopper support bar holds the hopper in the raised position to allow work under the hopper. DO NOT rely on the machine hydraulic system to keep the hopper raised.



**WARNING: Raised hopper may fall.
Engage hopper support bar.**

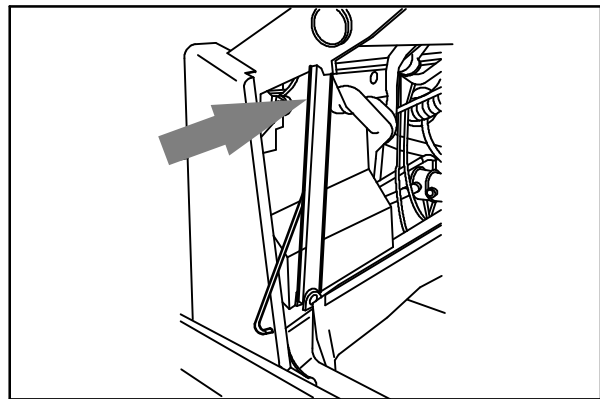

07803

OPERATION

OPERATOR SEAT

The operator seat is a fixed back style with a forward-backward adjustment.

Adjust: Remove the seat mounting bolts, move the seat to the position desired, and reinstall and tighten the bolts.

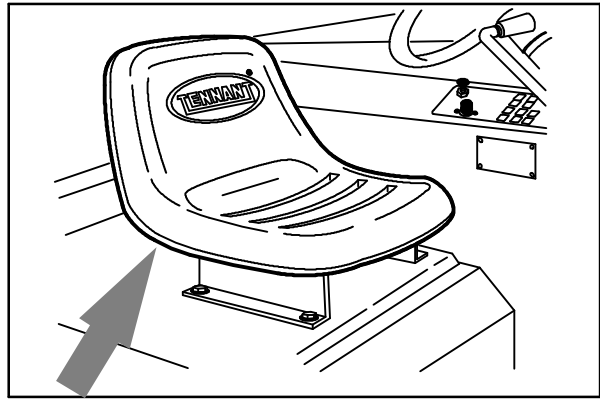

07798

Lift: Pull up on the seat mounting plate until the seat mount locks up.

Lower: Pull on the release lever and lower the seat mounting plate.

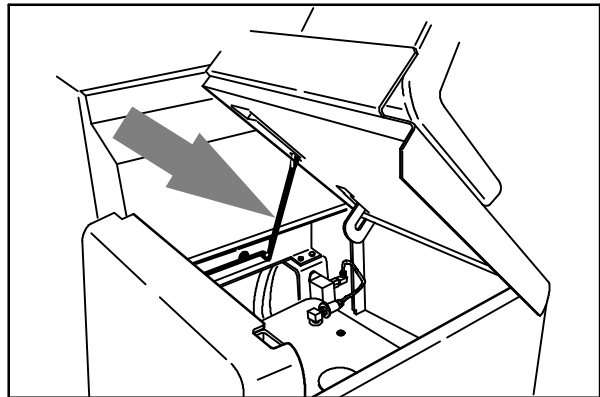

08052

WINDSHIELD WIPER SWITCH (OPTION)

The windshield wiper switch operates the windshield wiper on the cab option. The wiper can be operated at two speeds.

Slow: Press the top of the switch.

Fast: Press the bottom of the switch.

Off: Return the switch to the middle position.

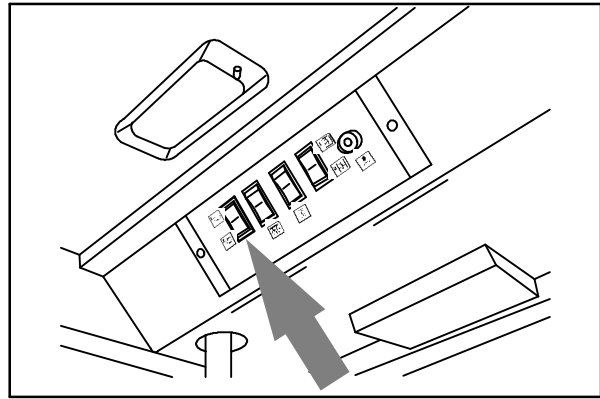

08129

DOME LIGHT SWITCH (OPTION)

The dome light switch controls the dome light on the cab option.

On: Press the top of the switch.

Off: Press the bottom of the switch.

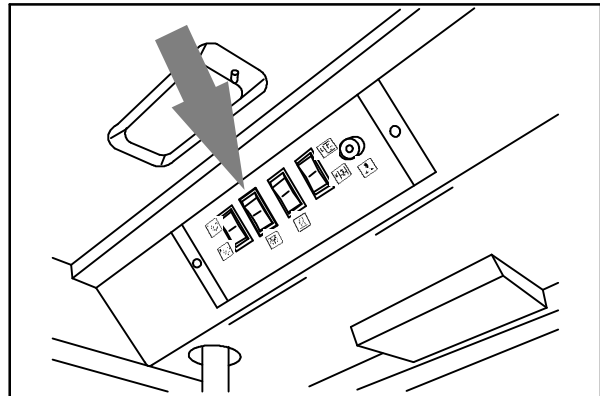

08130

HEATER SWITCH (OPTION)

The heater switch controls the cab heater on the cab option.

On: Press the top of the switch.

Off: Press the bottom of the switch.

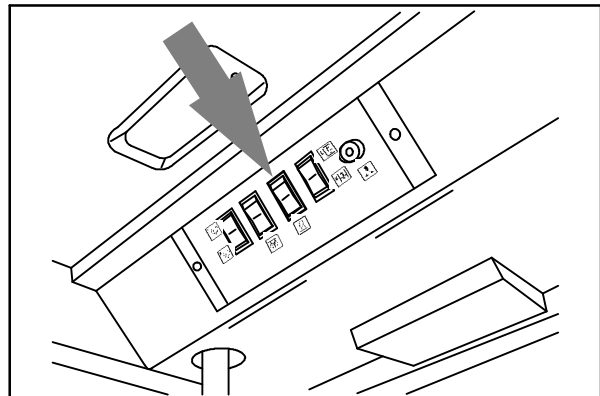

08131

PRESSURIZER SWITCH (OPTION)

The pressurizer switch operates the cab pressurizer on the cab option. The pressurizer can be operated at two speeds.

Slow: Press the top of the switch.

Fast: Press the bottom of the switch.

Off: Return the switch to the middle position.

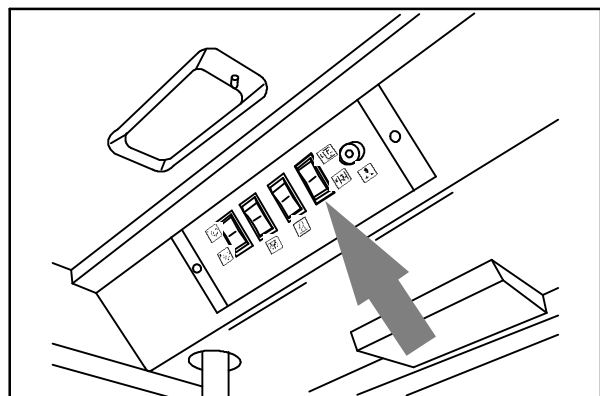

08132

OPERATION

HOW THE MACHINE WORKS

The steering wheel controls the direction of machine travel. The directional pedal controls the speed and forward/reverse direction. The brake pedal slows and stops the machine.

The side brush sweeps debris into the path of the main brush. The main brush sweeps debris from the floor into the hopper. The vacuum system pulls dust and air through the hopper and the hopper dust filter.

When sweeping is finished, clean the hopper dust filter and empty the hopper.

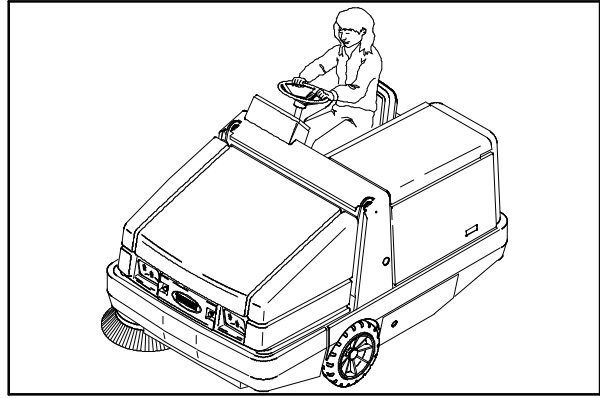

07816

PRE-OPERATION CHECKLIST

- Check under the machine for leaks (fuel, oil, coolant).

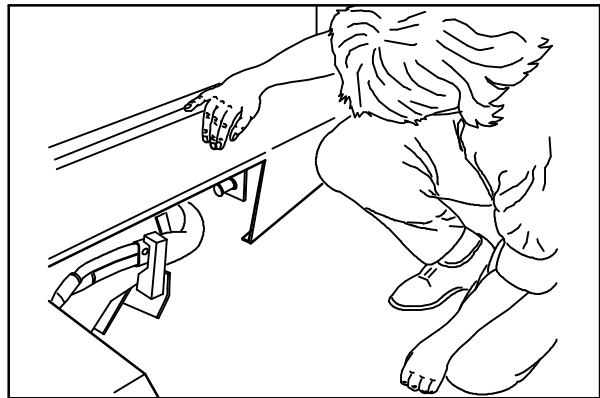

07807

- Check the engine air filter indicator.

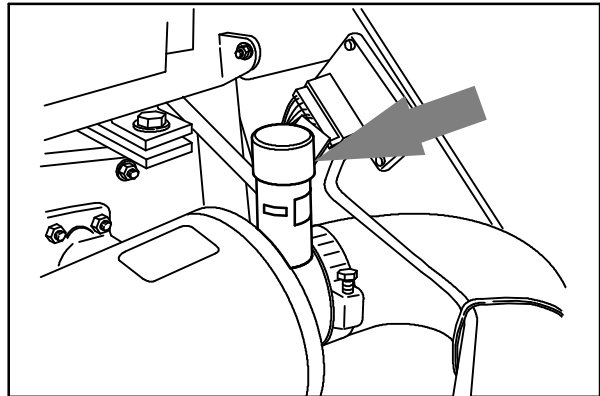

07808

- Check the engine oil level.

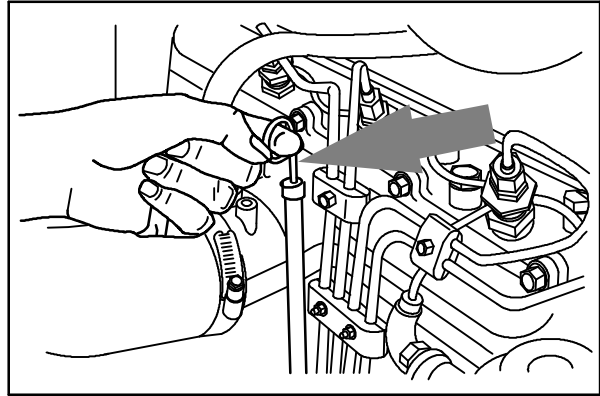

08431

- Check fuel level.

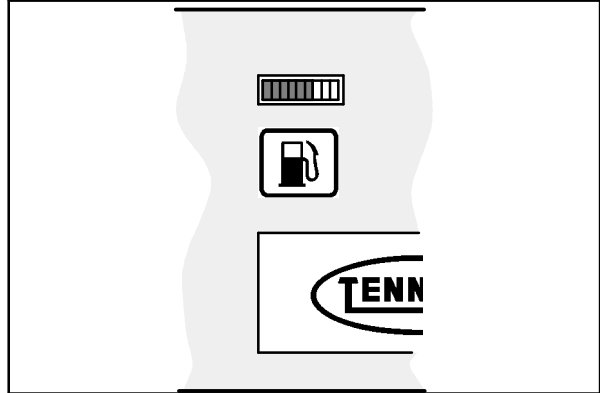

07764

- Check the brakes and steering for proper operation.

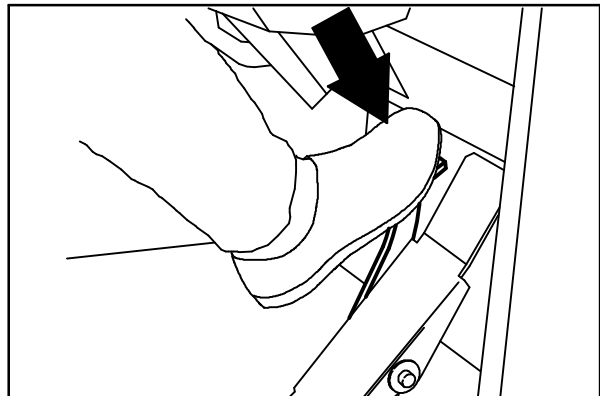

07754

STARTING THE MACHINE

1. You must be in the operator's seat with the directional pedal in neutral, and your foot on the brake pedal or with the parking brake set.

For Safety: When starting machine, keep foot on brake and directional pedal in neutral.

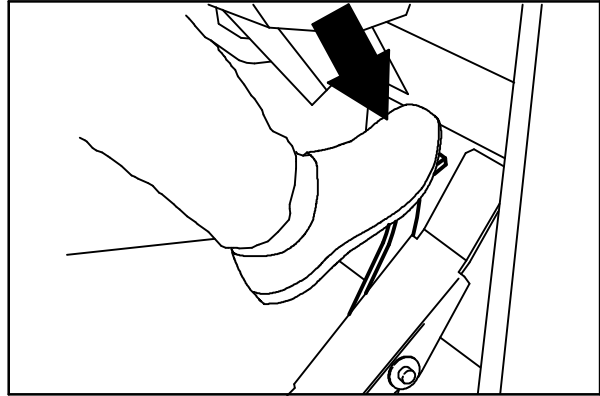

2. Turn the ignition switch key all the way counter-clockwise and hold it there for 15 to 60 seconds depending on the weather conditions.

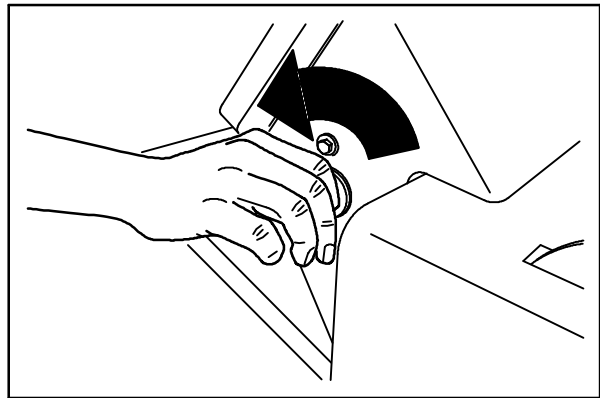

3. Turn the ignition switch key clockwise until the engine starts.

NOTE: Do not operate the starter motor for more than 10 seconds at a time or after the engine has started. Allow the starter to cool between starting attempts or damage to the starter motor may occur.

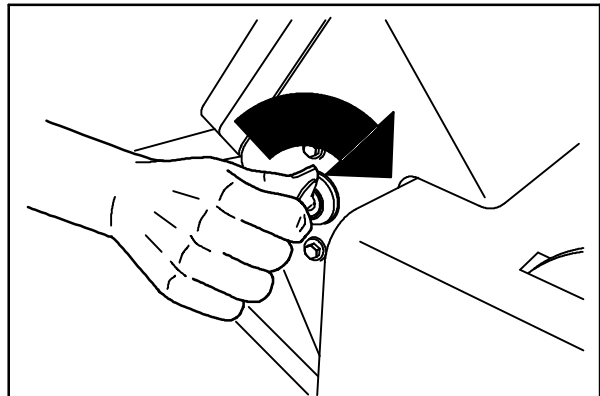

4. Allow the engine and hydraulic system to warm up three to five minutes.



WARNING: Engine emits toxic gases. Severe respiratory damage or asphyxiation can result. Provide adequate ventilation. Consult with your regulatory authorities for exposure limits. Keep engine properly tuned.

5. Release the machine parking brake.

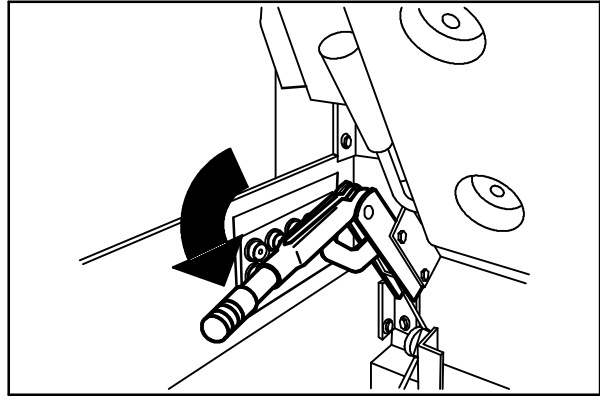

07793

6. Select the (Fast 1) engine speed with the engine speed switch.

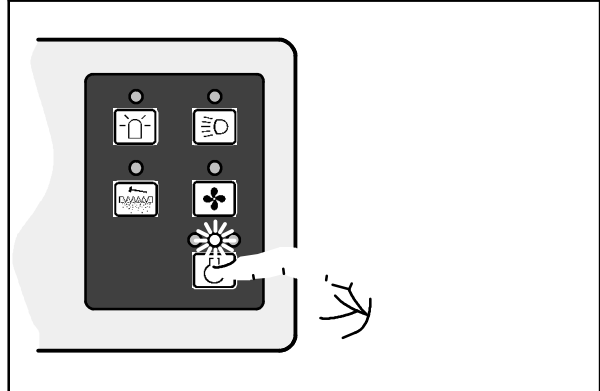

07771

7. Drive the machine to the area being swept.

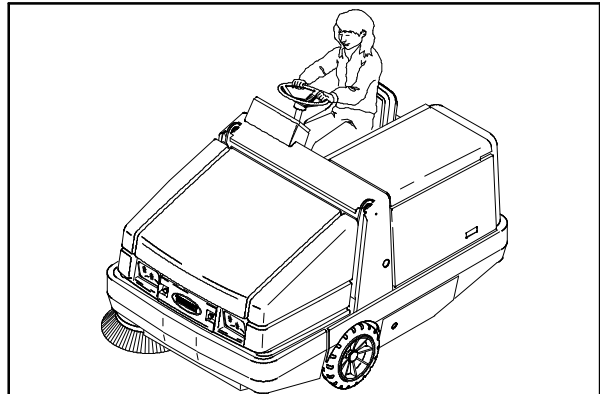

07816

SWEEPING AND BRUSH INFORMATION

Pick up oversized debris before sweeping. Flatten or remove bulky cartons from aisles before sweeping. Pick up pieces of wire, twine, string, etc., which could become entangled in brush or brush plugs.

Plan the sweeping in advance. Try to arrange long runs with minimum stopping and starting. Sweep debris from very narrow aisles into main aisles ahead of time. Do an entire floor or section at one time. Sweep as straight a path as possible. Avoid bumping into posts or scraping the sides of the sweeper. Overlap the brush paths.

Avoid turning the steering wheel too sharply when the machine is in motion. The machine is very responsive to the movement of the steering wheel. Avoid sudden turns, except in emergencies.

Speed up the engine to (Fast 2) when picking up light litter. This will improve both litter pickup and hopper loading. Do not use the (Fast 2) speed in dusty environments. The machine can dust and clog the hopper dust filter. Operate the engine in the (Fast 1) position when picking up general debris.

For best results, use the correct brush type for your sweeping application. The following are recommendations for main and side brush applications.

Nylon 8-double Row Main Brush -

Recommended for general sweeping, and has good hopper loading. Nylon has the longest life of the bristle types. Use this brush for sweeping rough or irregular surfaces.

Polypropylene and Wire 8-double Row Main Brush - The wire bristles loosen slightly packed soilage and heavier debris. The polypropylene bristles sweep up the debris with excellent hopper loading.

Crinkle Wire 8-double Row Main Brush - The stiff wire bristles cut through compacted grime, hard to sweep dirt, and dirt mixed with oil, grease, or mud. This brush is recommended for foundry sweeping where heat may melt synthetic bristles. This brush has good hopper loading ability, but is not recommended for dusty applications.

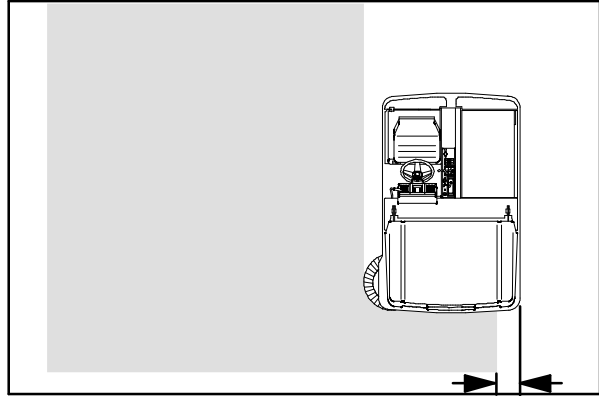

07817

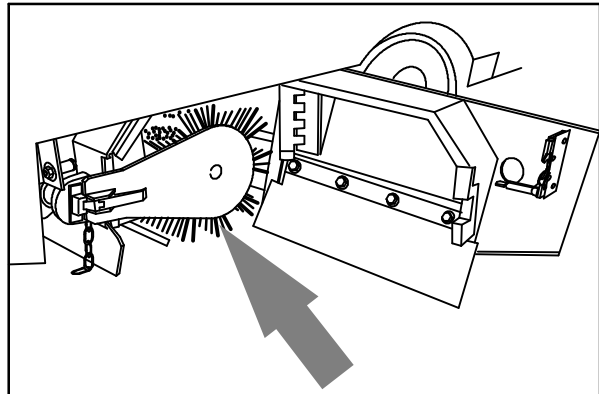

08002

Nylon 24-row Main Brush – Recommended for severe dust conditions on rough surfaces. This brush has excellent pickup and long life.

Fiber and Wire 24-row Main Brush – Offers good sweeping action and pickup in heavy dust concentrations. This brush is recommended where soilage is slightly encrusted. The brush is not recommended for heavy buildup or hard packed soilage.

Polypropylene Side Brush – A good general purpose brush for sweeping of light to medium debris in both indoor and outdoor applications. This brush is recommended when bristles may get wet.

Nylon Side Brush – A longer life, general purpose brush that is recommended for rough surfaces.

Flat Wire Side Brush – Recommended for outside and curb-side sweeping where soilage is heavy or compacted. The stiff wire bristles dig out soilage. This brush is also recommended for foundry sweeping where heat may melt synthetic bristles.

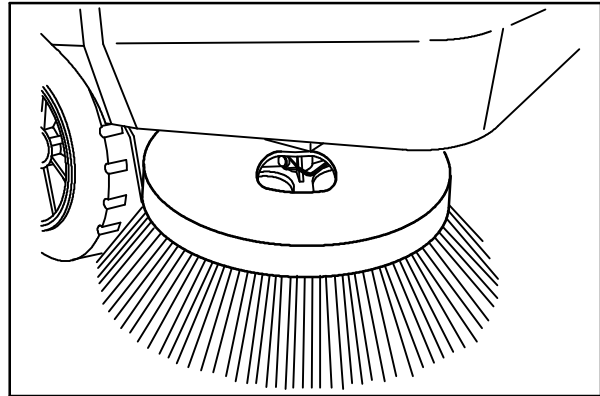

08046

SWEEPING

1. Select an engine speed.

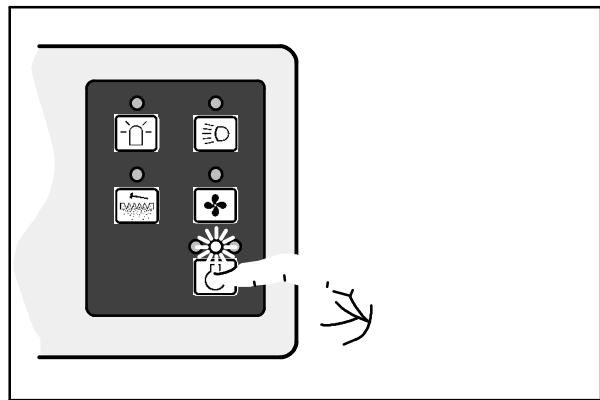

07771

2. Make sure the hopper door light is off. If the hopper door light is on, open the hopper door.

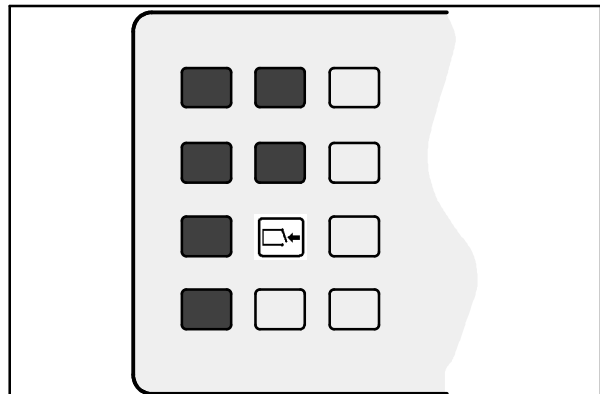

07763

OPERATION

3. Push the main brush and side brush lever into the **On** position, or pull the lever into the **On** position.

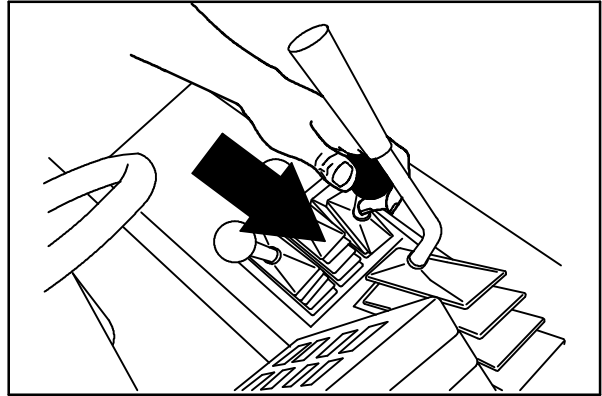

07773

4. Press the vacuum fan switch to start the vacuum.

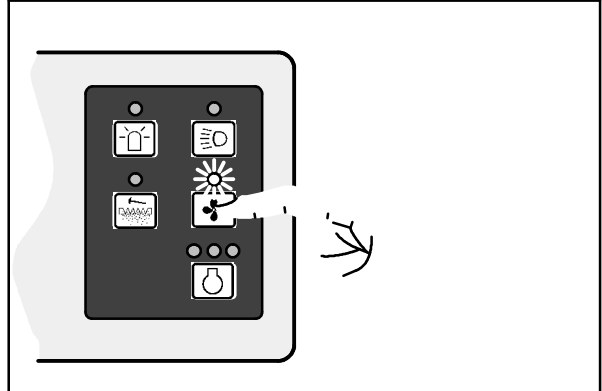

07769

5. Pull the main brush position lever back and to the left into the **Down** position.

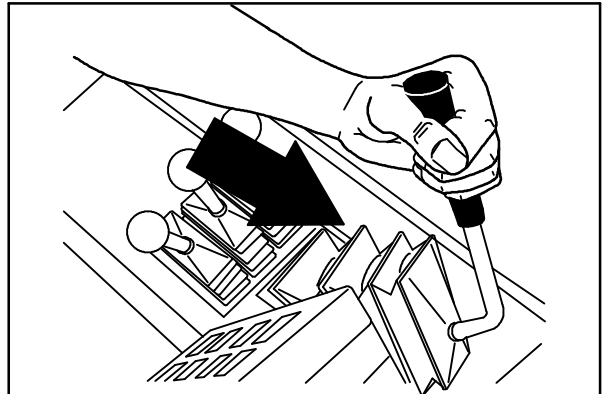

07782

6. Pull the side brush position lever back and to the right into the **Down** slot.

7. Sweep as needed.

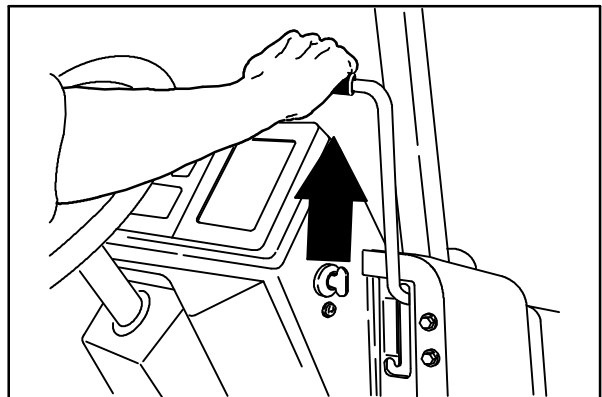

07785

STOP SWEEPING

1. Pull the main brush position lever all the way back and to the right into the **Up** position.

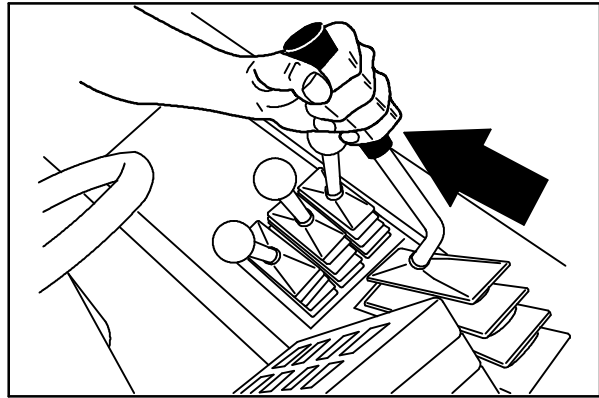

07784

2. Pull the side brush position lever back and to the left into the **Up** slot.

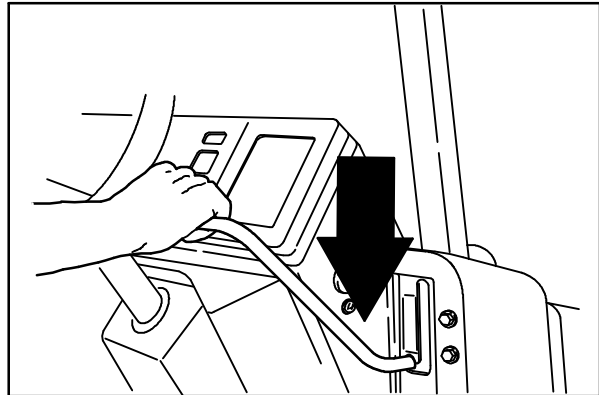

07786

3. Pull the main brush and side brush lever into the middle (Off) position.

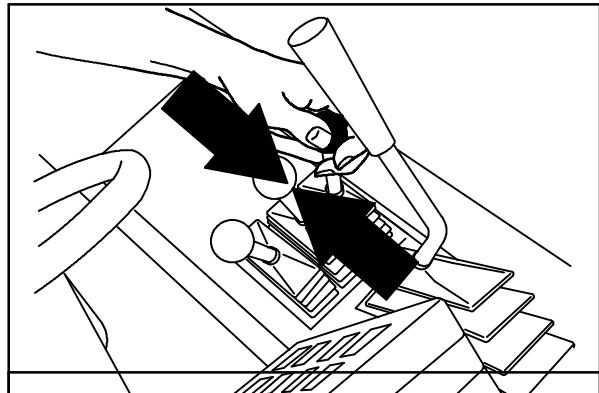

07774

4. Press the filter shaker switch to shake the hopper dust filter.

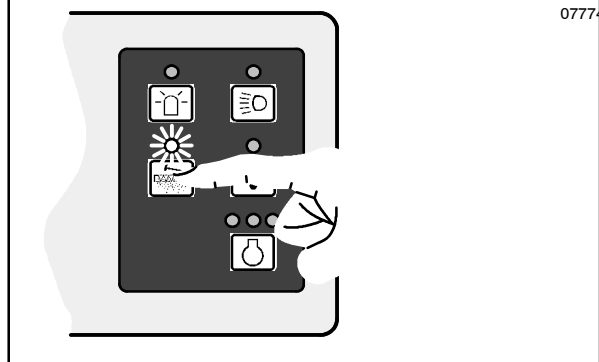

07767

EMPTYING THE HOPPER

1. Slowly drive the machine to the debris site or debris container.

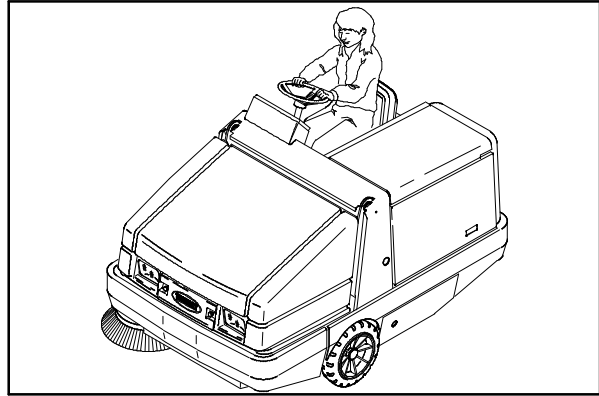

07816

2. Pull the hopper door lever into the **Close** position until the hopper door light comes on.

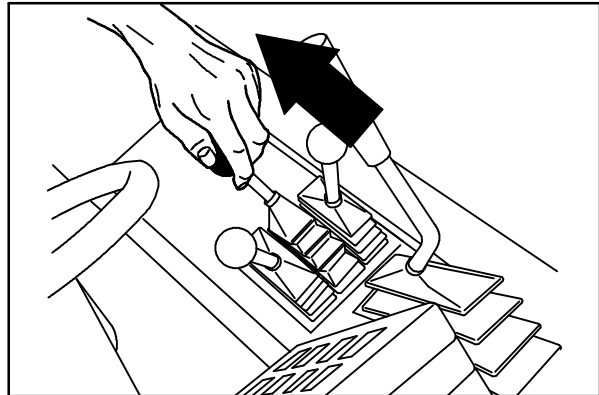

07778

3. Release the hopper door lever into the middle (Hold) position.

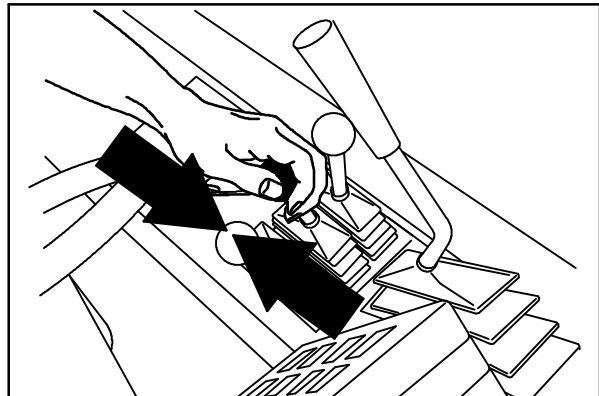

07777

4. Pull the hopper lift lever into the **Up** position and raise the hopper to the desired height.

FOR SAFETY: When using machine, make sure adequate clearance is available before raising hopper.

NOTE: Be aware that the minimum ceiling height needed to high dump the hopper is 2745 mm (9 ft).

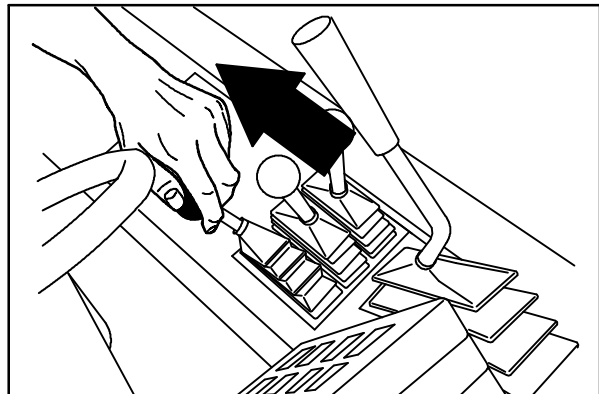

07779

5. Release the hopper lift lever up and into the middle (Hold) position.

FOR SAFETY: When using machine, move machine with care when hopper is raised.

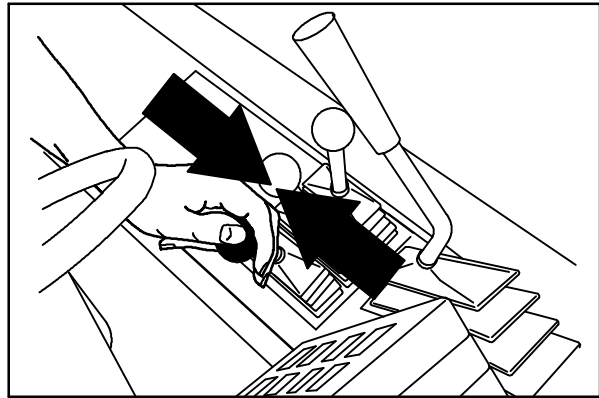

07780

6. Drive the machine up to the debris container.
7. Lower the hopper into the debris container to control dust.
8. Push the hopper door lever into the **Open** position and leave it there.

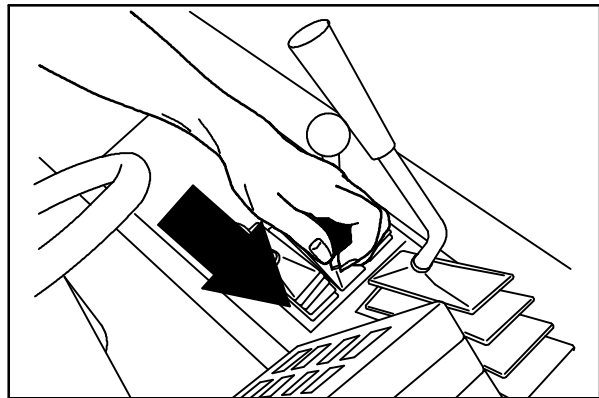

07776

9. Raise the hopper enough and/or close the hopper door to clear the top of the debris container.

10. Slowly back the machine away from the debris site or debris container.

For Safety: When using machine, use care when reversing machine.

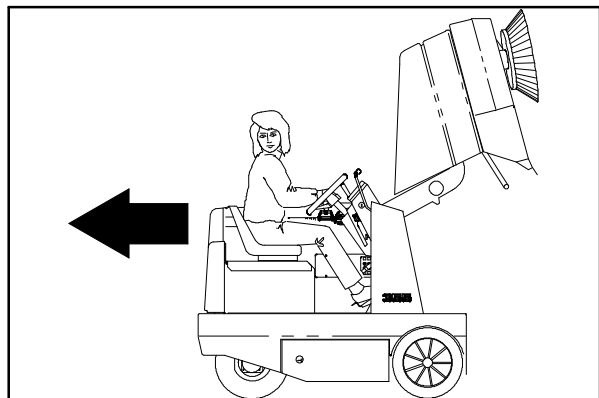

07999

11. Push the hopper lift lever into the **Down** position.

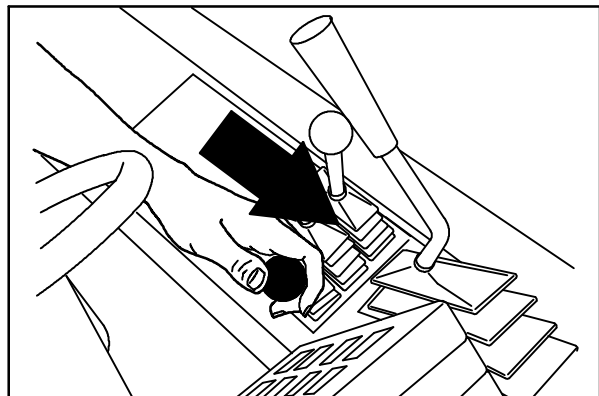

07781

STOP THE MACHINE

1. Stop sweeping.
2. Take your foot off the directional pedal. Step on the brake pedal.

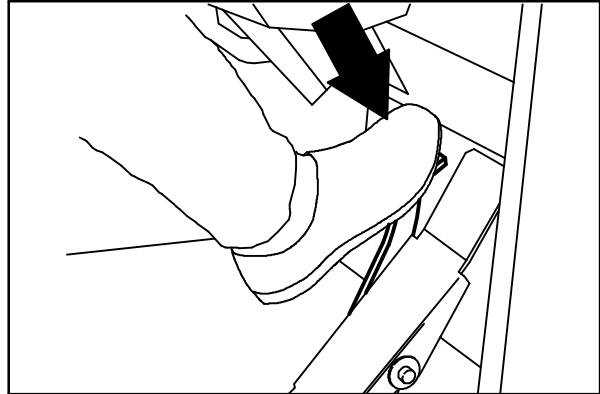

07754

3. Select the (Idle) position with the engine speed switch.

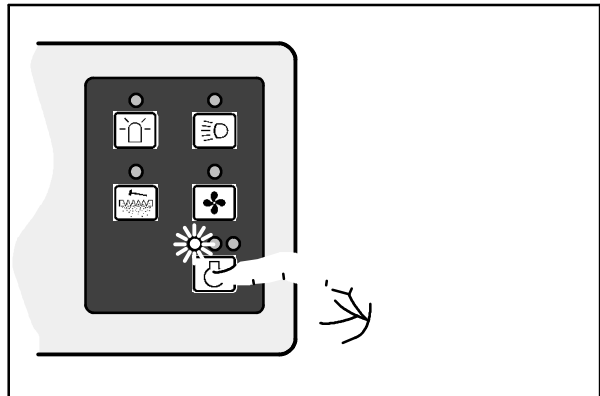

07770

4. Set the machine parking brake.

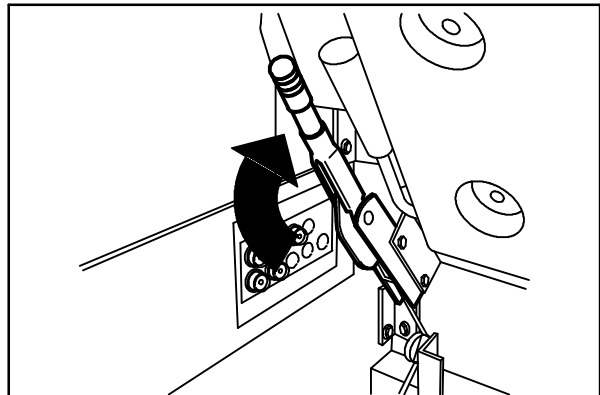

07794

5. Turn the ignition switch key counter-clockwise to stop the engine. Remove the switch key.

FOR SAFETY: Before leaving or servicing machine; stop on level surface, set parking brake, turn off machine and remove key.

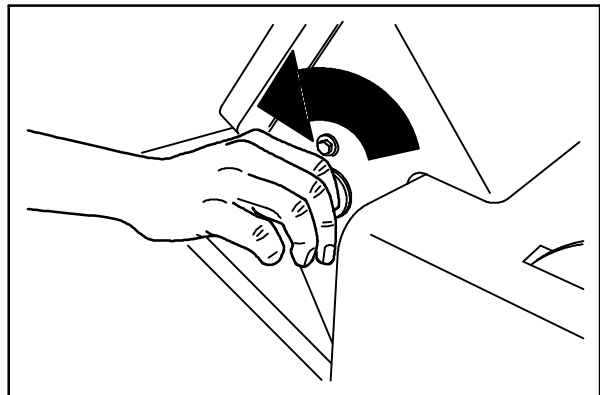

07805

POST-OPERATION CHECKLIST

- Check the brush skirts for damage, wear, and adjustment.

- Check the brushes adjustment. See *TO CHECK AND ADJUST MAIN BRUSH PATTERN* and *SIDE BRUSH* in *MAINTENANCE*.

- Check for wire or string tangled on the main and side brushes

- Check for fuel odor that indicates a fuel leak.

- Check under the machine for leak spots (fuel, oil, coolant).

- Check the service records to determine maintenance requirements.

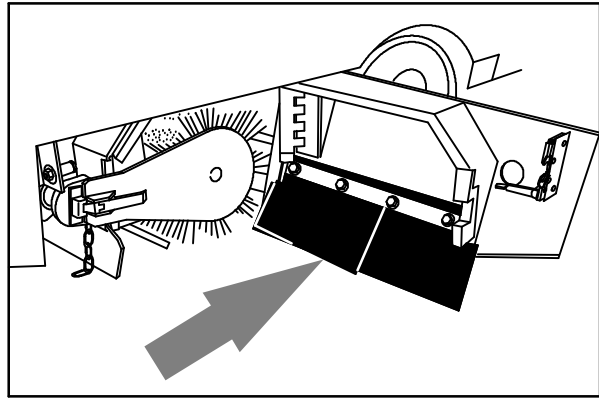

08001

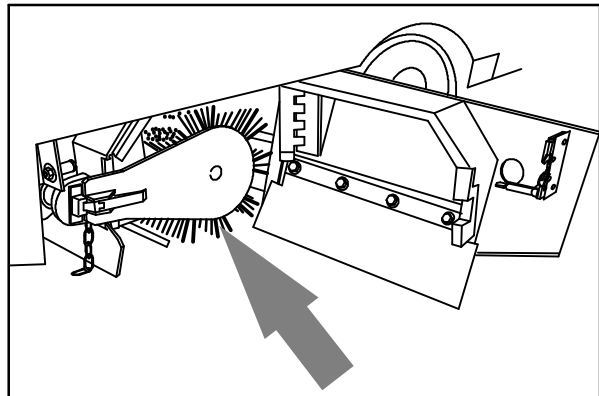

08002

ENGAGING HOPPER SUPPORT BAR

1. Set the machine parking brake.

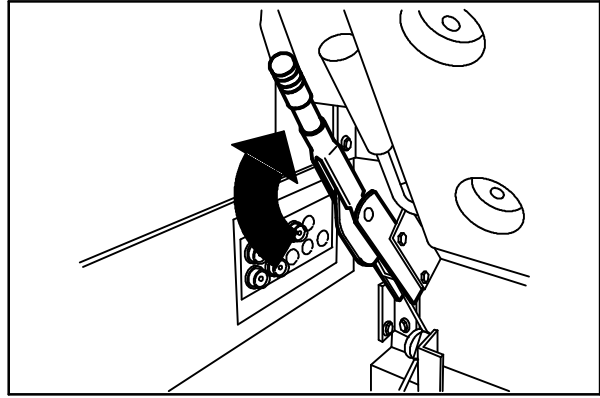

2. Start the engine.

For Safety: When starting machine, keep foot on brake and directional pedal in neutral.

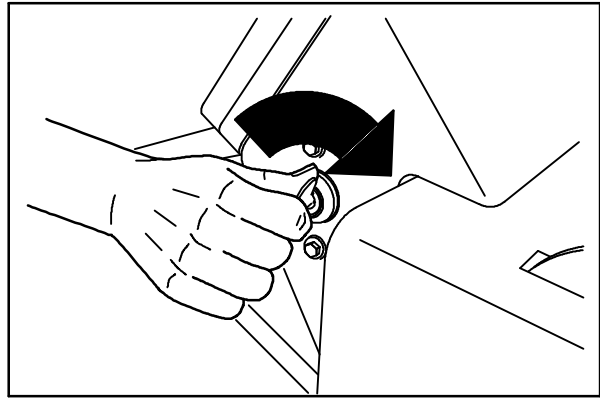

3. Raise the hopper all the way up.

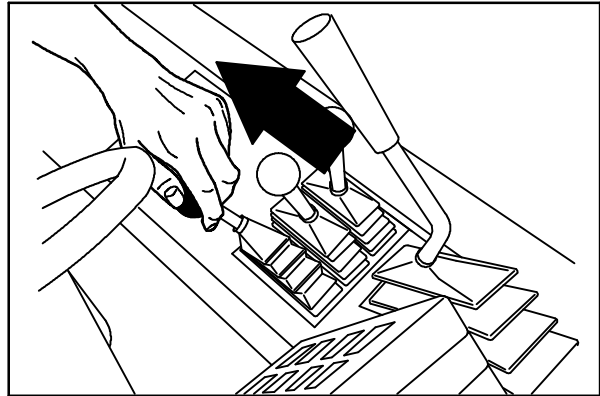

4. Lift and position the hopper support bar under the hopper lift arm.

 **WARNING: Raised hopper may fall. Engage hopper support bar.**

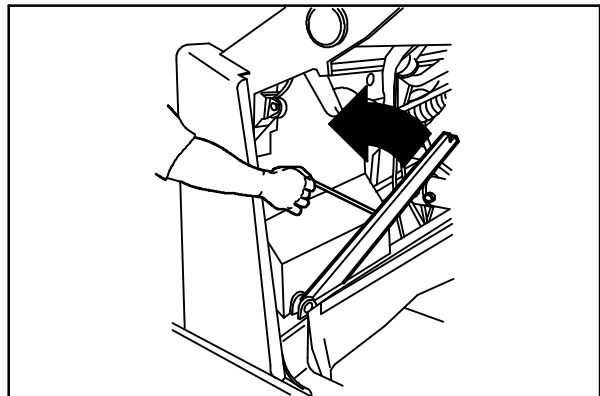

5. Slowly lower the hopper so the lift arm rests on the support bar.

⚠ WARNING: Lift arm pinch point. Stay clear of hopper lift arms.

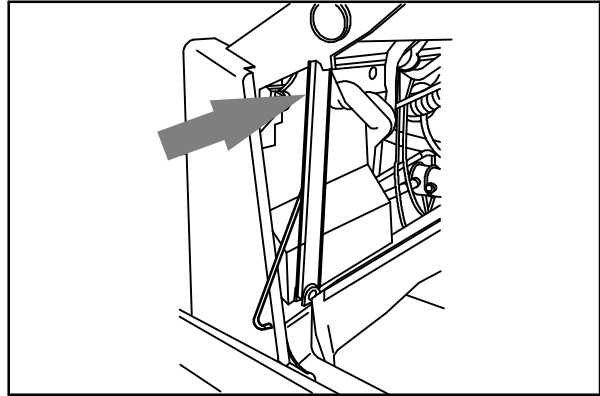

07803

6. Shut the engine off.

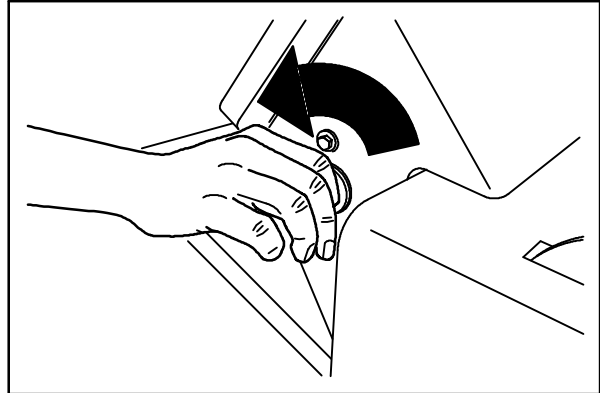

07805

DISENGAGING HOPPER SUPPORT BAR

1. Start the engine.

For Safety: When starting machine, keep foot on brake and directional pedal in neutral.

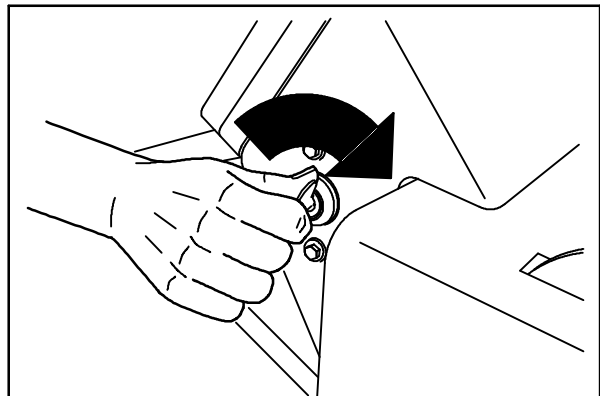

07804

2. Raise the hopper slightly to release the hopper support bar.

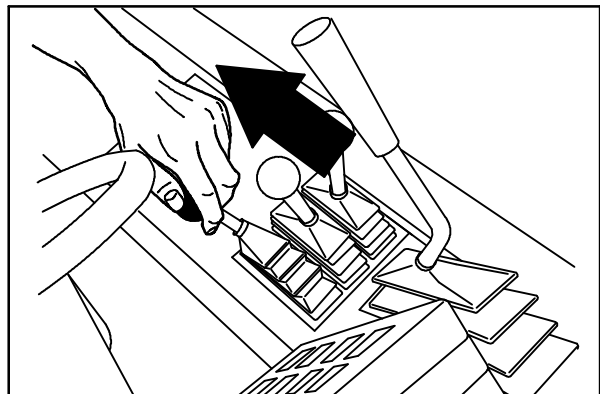

07779

OPERATION

- Put the support bar in its storage position.

 **WARNING: Lift arm pinch point. Stay clear of hopper lift arms.**

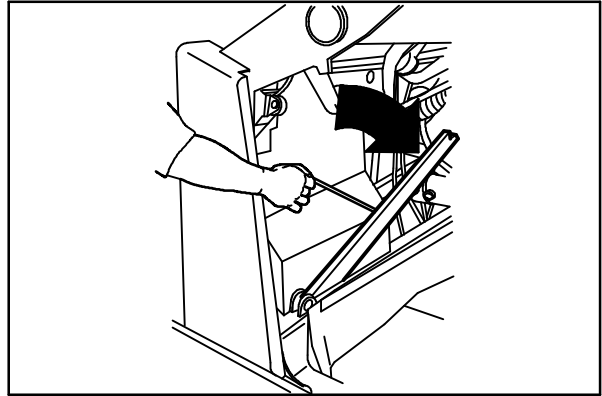

08004

- Lower the hopper.

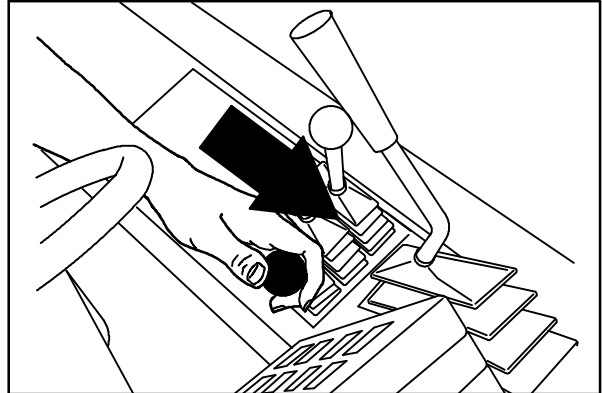

07781

- Shut the engine off.

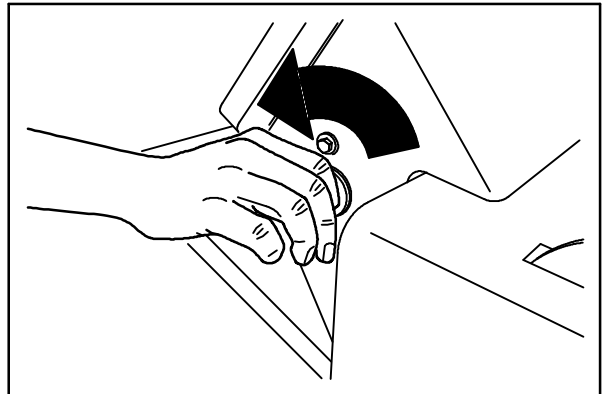

07805

OPERATION ON INCLINES

Drive the machine slowly on inclines. Use the brake pedal to control machine speed on descending inclines.

The maximum rated incline is 6°.

For Safety: When using machine, go slow on inclines.

OPTIONS

VACUUM WAND

The vacuum wand uses the machine's vacuum system. The vacuum hose and wand allow pick-up of debris that is out of reach of the machine.

1. Stop the machine within reach of the area to be vacuumed.
2. Shut the engine off.

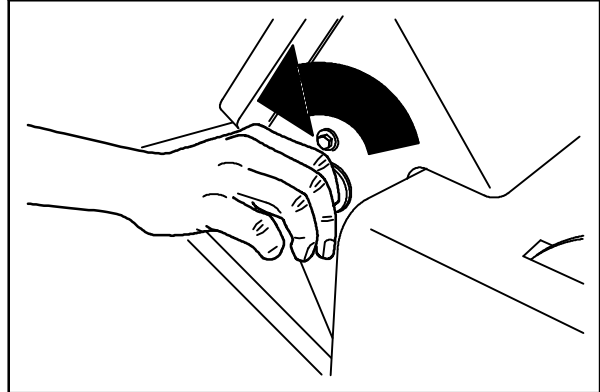

07805

3. Set the machine parking brake.

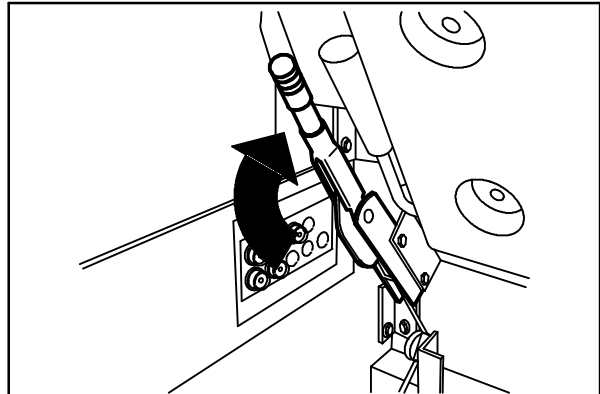

07794

4. Open the hopper cover.

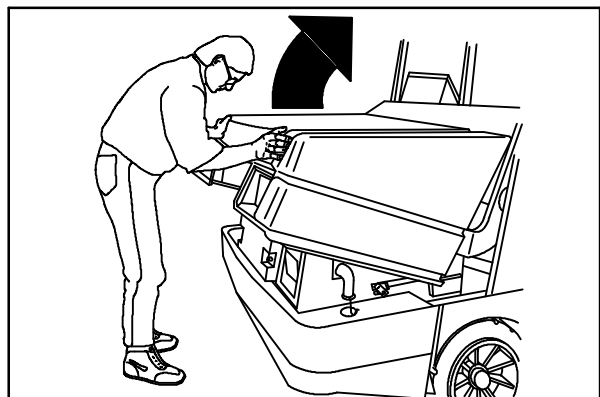

08133

OPERATION

5. Remove the vacuum plug from the side of the hopper.

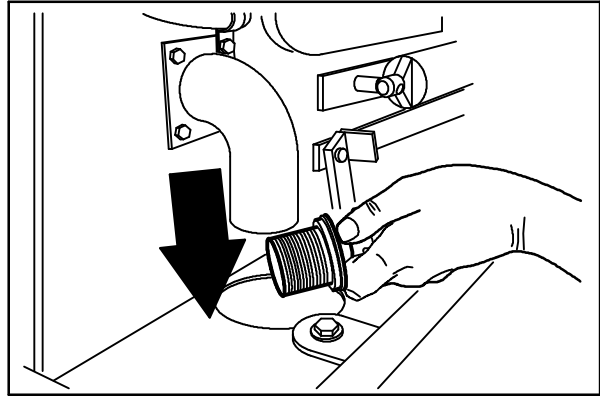

08134

6. Remove the vacuum wand and hose from the mounting clips.

7. Connect the vacuum hose to the hopper connection.

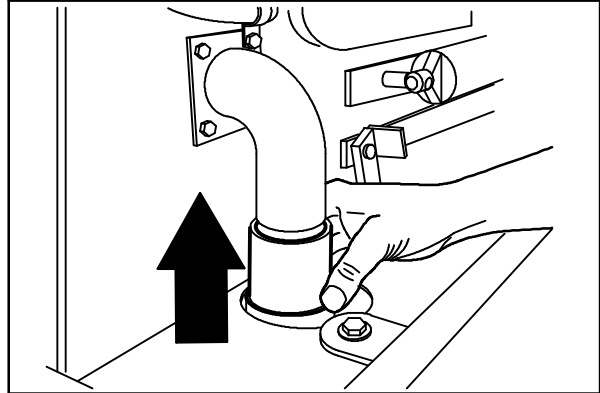

08136

8. Close the hopper cover.

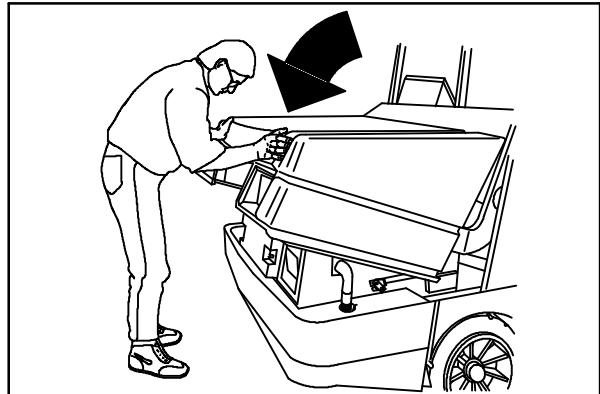

08728

9. Connect the vacuum hose to the vacuum wand.

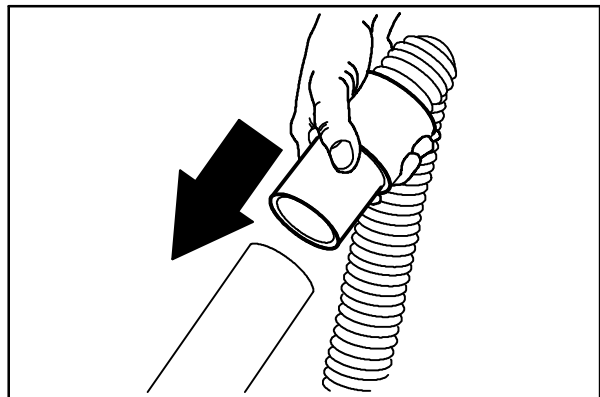

08138

10. Start the engine.

For Safety: When starting machine, keep foot on brake and directional pedal in neutral.

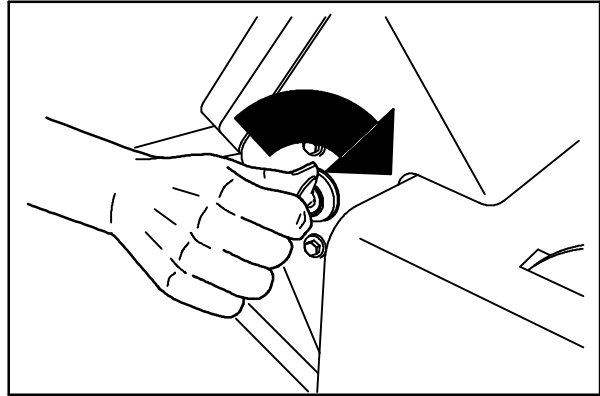

07804

11. Select the (Fast 2) engine speed with the engine speed switch.

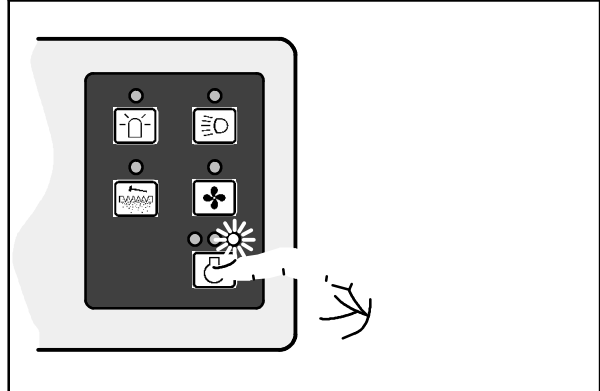

07772

12. Pull and hold the hopper door lever into the **Close** position until the hopper door light comes on.

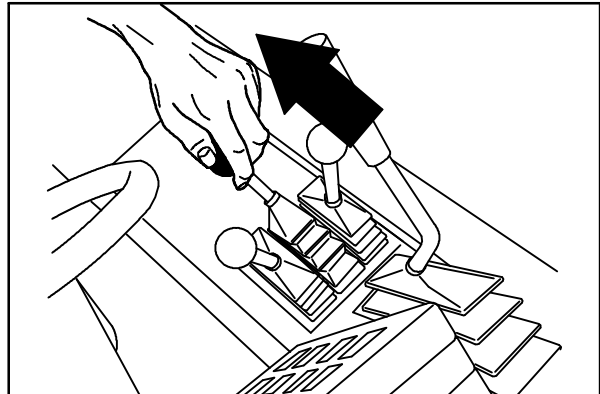

07778

13. Push the main brush and side brush lever into the **On** position.

NOTE: Always raise the brushes when turning them on for the vacuum wand. This prevents them from making brush marks in the floor.

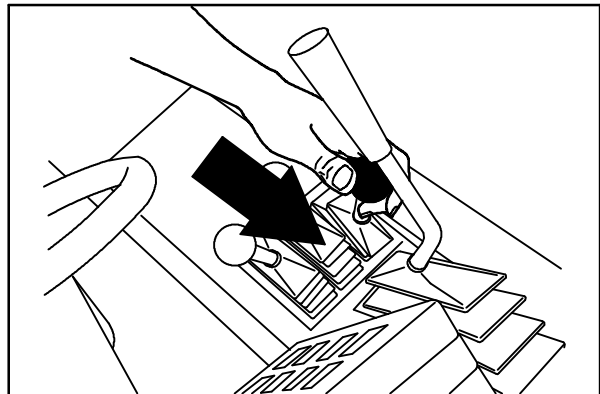

07773

OPERATION

14. Press the vacuum fan switch to start the vacuum.

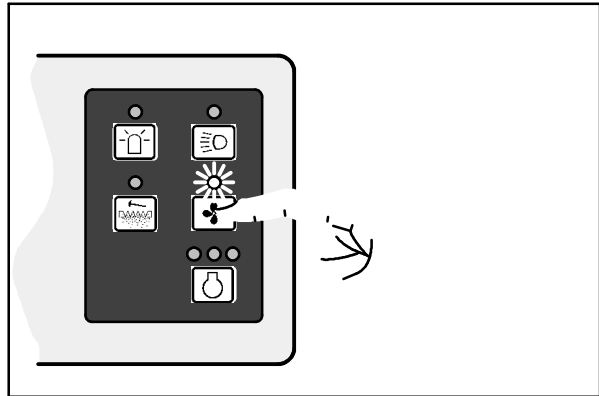

07769

15. Vacuum the area as needed.



08140

16. Pull the main brush and side brush lever into the middle position.

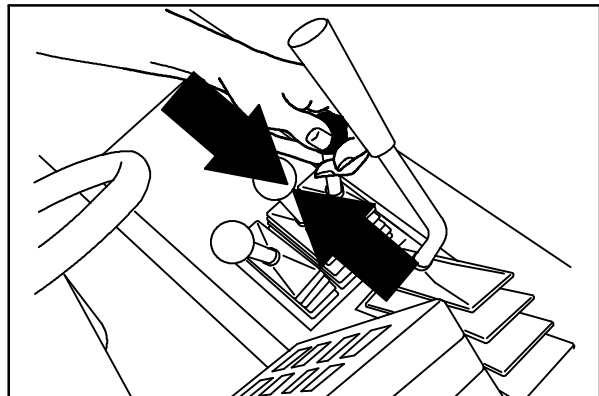

07774

17. Press the vacuum switch to shut off the vacuum.

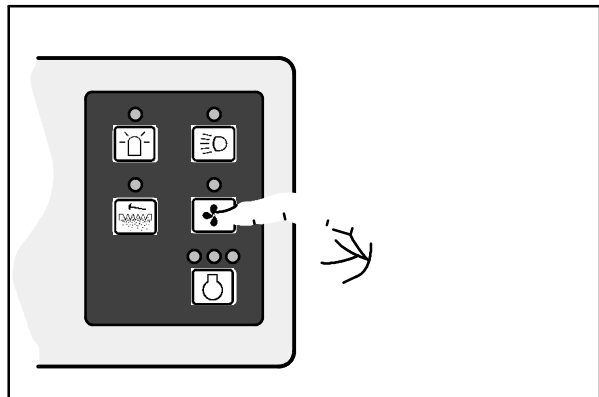

07998

18. Push the hopper door lever into the **Open** position and leave it there.

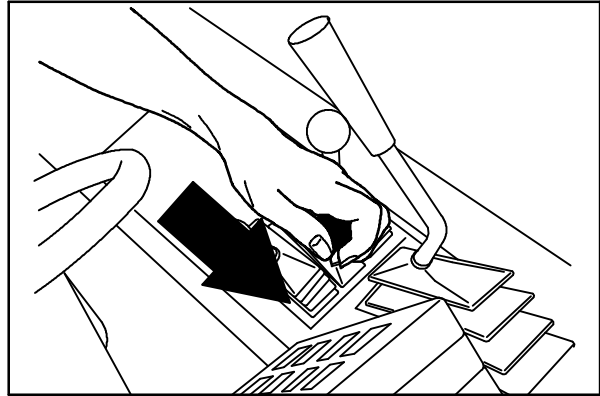

07776

19. Shut the engine off.

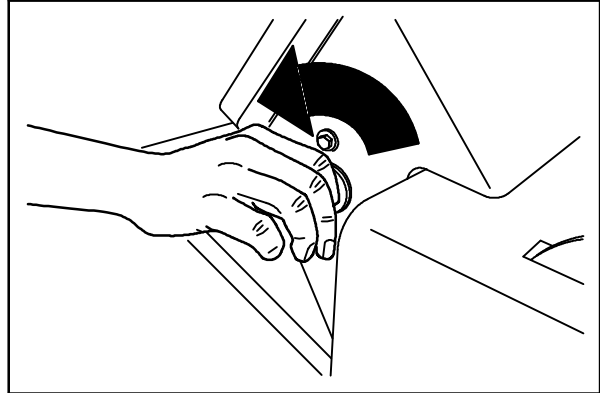

07805

20. Open the hopper cover.

21. Remove the vacuum hose from the hopper connection.

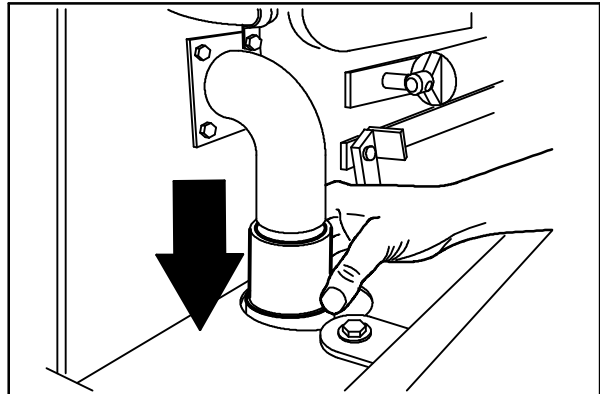

08137

22. Put the vacuum plug in the hopper connection.

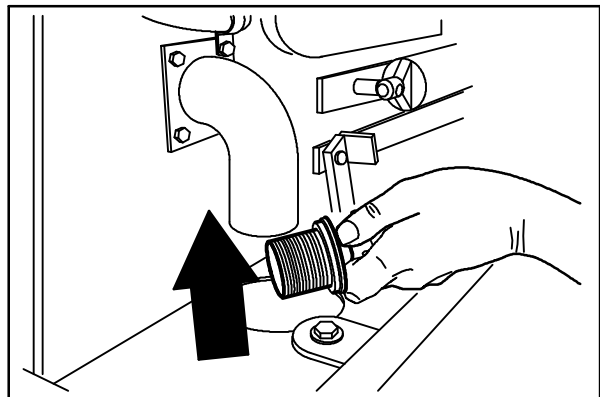

08135

23. Close the hopper cover.

OPERATION

24. Disconnect the vacuum hose from the vacuum wand.

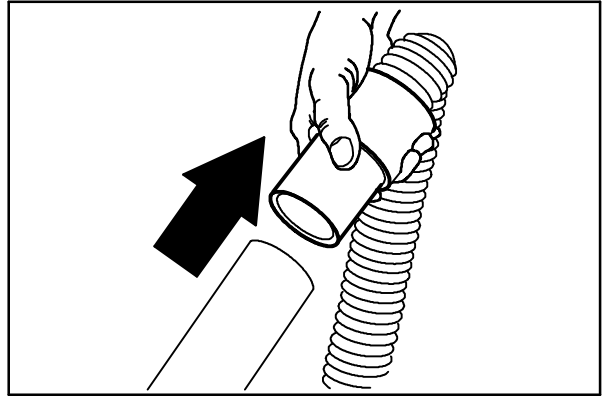

08139

25. Put the vacuum wand and hose in the mounting clips.

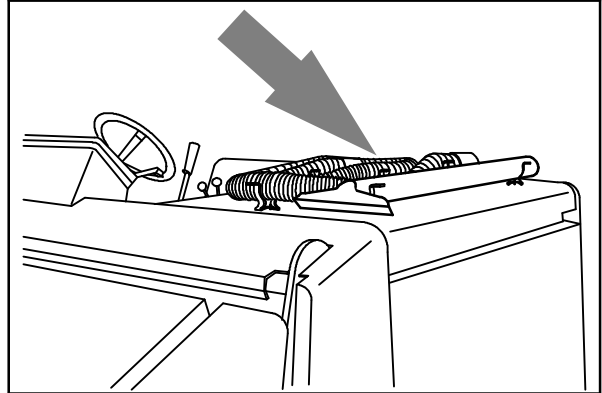

08141

BLOWER WAND

The blower wand uses the machine's vacuum exhaust. The blower wand allows the operator to blow debris out from areas while sweeping with the machine.

1. Remove the blower attachment from the back of the machine.

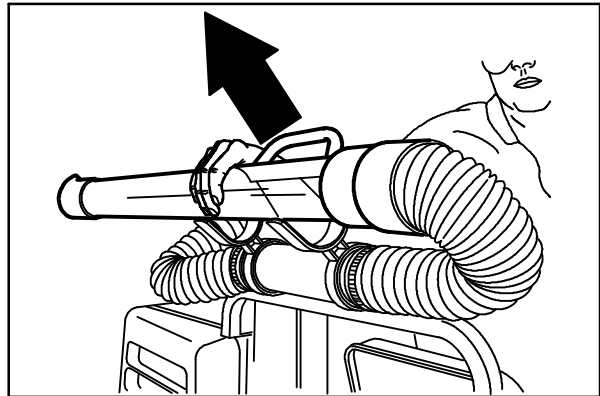

08142

2. Move the lever on the engine cover forward into the **ON** position to start airflow through the wand.

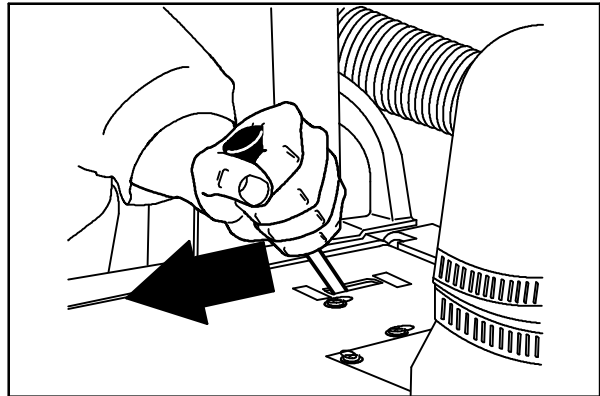

08144

3. Direct the wand into the area of debris.

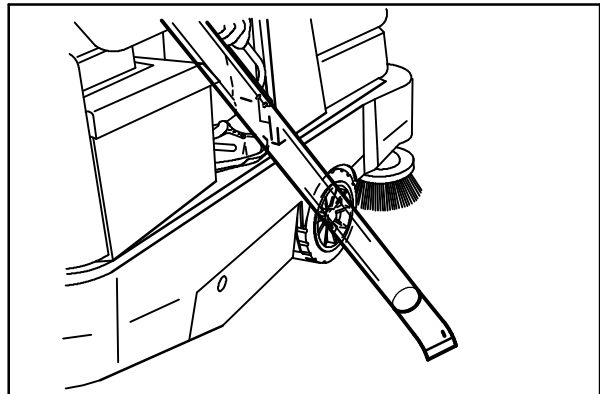

08146

OPERATION

The operator can rest the wand on the side bracket.

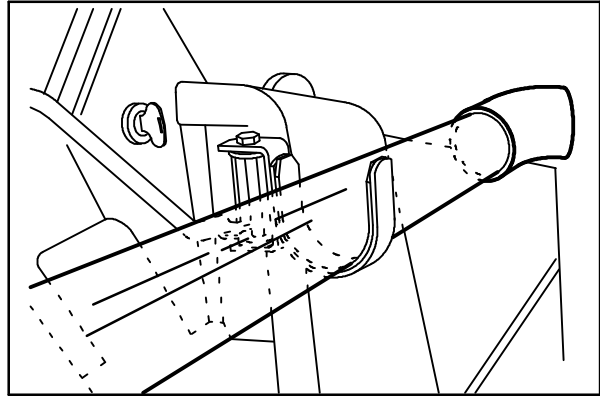

08147

4. Move the lever on the engine cover backward into the **OFF** position to stop airflow through the wand.

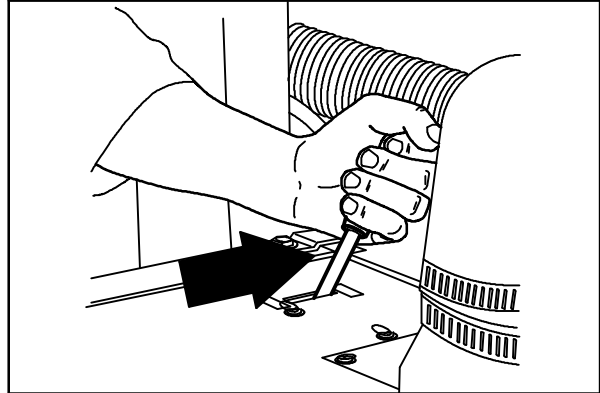

08145

5. Put the blower attachment on the back of the machine.

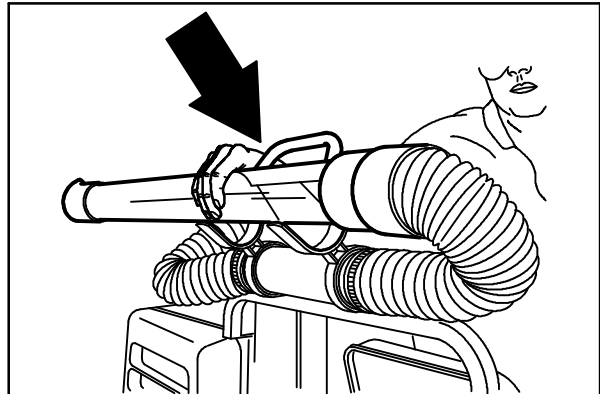

08143

TIE-DOWNS

The machine can be tied down for transport using the tie-down brackets at the front and rear of the machine.

The front tie-down bracket is above the front tires.

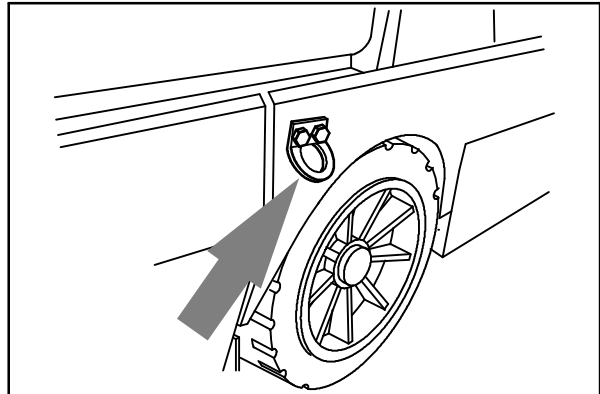

08152

The rear tie down is located on both sides of the tail light bracket under the rear bumper.

When transporting the machine on a trailer or in a truck, be sure to set the parking brake and block the tires to prevent the machine from rolling.

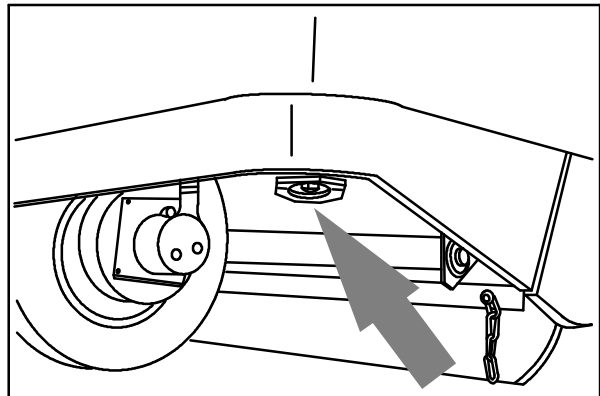

08151

OPERATION

HEATER VALVE

The heater valve is located at the bottom of the engine compartment. The valve controls the flow of hot coolant to the heater core.

Turning the valve handle 90° to the valve opens the valve, allowing coolant to flow to the heater core. Turning the handle straight with the valve closes the valve, stopping the flow.

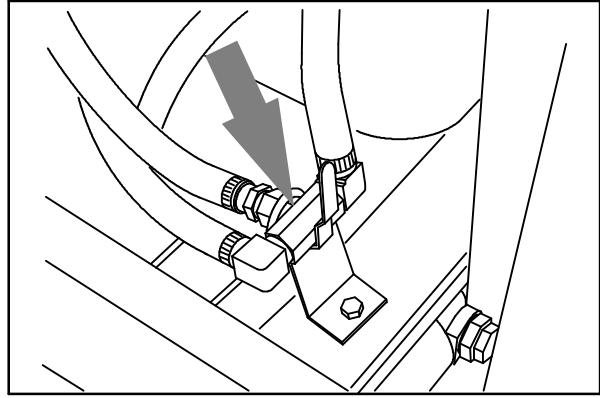

08569

MACHINE TROUBLESHOOTING

Problem	Cause	Remedy
Excessive dusting	Brush skirts and dust seals worn, damaged, out of adjustment	Replace or adjust brush skirts or dust seals
	Hopper dust filter clogged	Shake and/or clean or replace dust filter
	Engine operating at (Fast 2) speed	Operate engine at (Fast 1) speed
	Vacuum hose damaged	Replace vacuum hose
	Vacuum fan failure	Contact TENNANT service personnel
	Hopper door partially or completely closed	Open the hopper door
	Thermo Sentry™ tripped	Reset Thermo Sentry™
Poor sweeping performance	Brush bristles worn	Replace brushes
	Main and side brushes not adjusted properly	Adjust main and side brushes
	Debris caught in main brush drive mechanism	Free drive mechanism of debris
	Main brush drive failure	Contact TENNANT service personnel
	Side brush drive failure	Contact TENNANT service personnel
	Hopper full	Empty hopper
	Hopper lip skirts worn or damaged	Replace lip skirts
	Hopper door partially or completely closed	Open the hopper door
	Wrong sweeping brush	Contact TENNANT representative for recommendations
	Main brush in Down position	Put main brush in Float position

MAINTENANCE

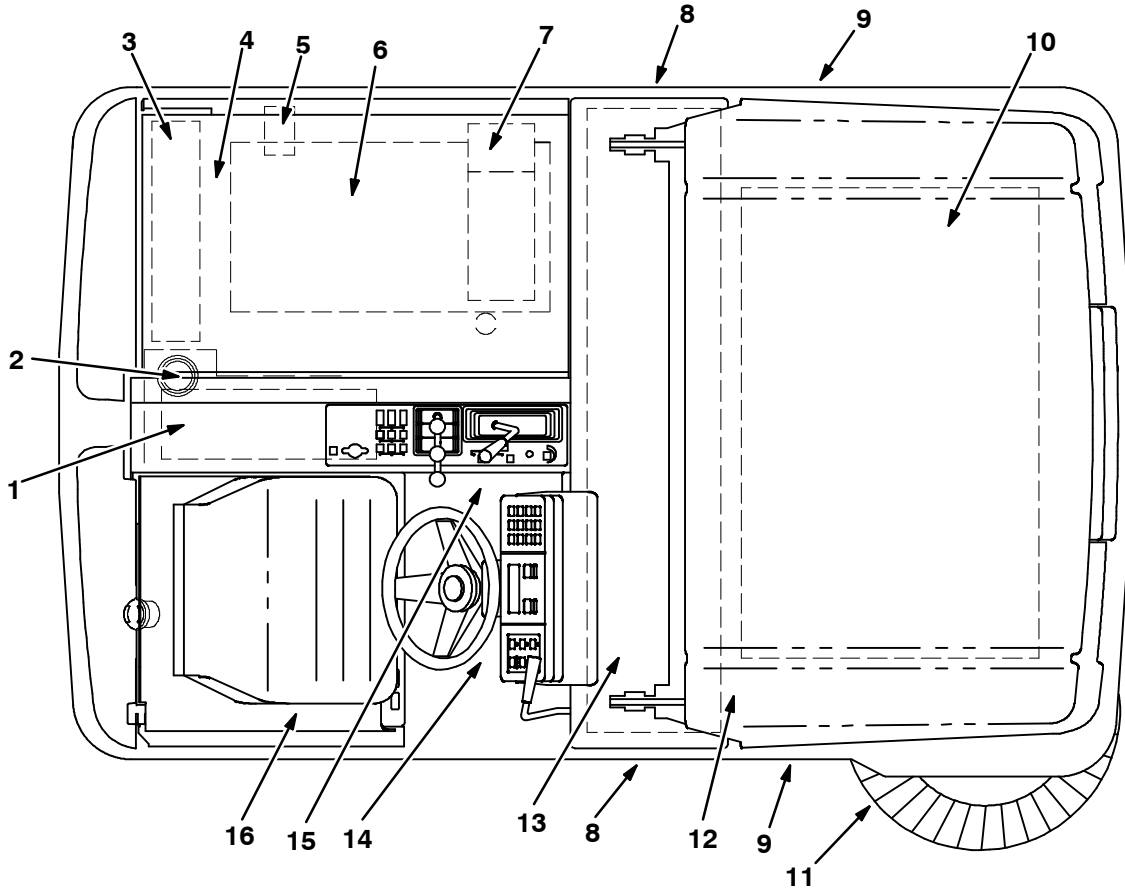

07747

MAINTENANCE CHART

Interval	Key	Description	Procedure	Lubricant/ Fluid	No. of Service Points
Daily	7	Engine air filter	Check indicator	-	1
			Empty dust cap	-	1
	6	Engine crankcase	Check oil level	EO	1
	8	Brush compartment skirts	Check for damage, wear and adjustment	-	5
	12	Hopper lip skirts	Check for damage, wear and adjustment	-	3
	12	Hopper side skirt	Check for damage and wear	-	1
	13	Main brush	Check for damage, wear, and adjustment	-	1
			Check brush pattern	-	1
	11	Side brush	Check for damage, wear, and adjustment	-	1
Check brush pattern			-	1	

Interval	Key	Description	Procedure	Lubricant/ Fluid	No. of Service Points
50 Hours	13	Main brush	Rotate end-for-end	-	1
	6	Fuel pipes and clamps	Check for tightness and wear	-	1
100 Hours	6	Engine crankcase	Change oil and filter	EO	1
	4	Engine fan belt	Check tension	-	1
	10	Hopper dust filter	Check for damage, clean or re- place	-	1
	3	Radiator	Clean core exterior	-	1
			Check coolant level	WG	1
	2	Hydraulic fluid reservoir	Check fluid level	HYDO	1
	1	Rear tire	Check pressure	-	1
	8	Main brush and hopper seals	Check for damage or wear	-	8
200 Hours	3	Radiator hoses and clamps	Check for tightness and wear	-	2
	15	Parking brake	Check adjustment	-	1
	14	Brake pedal	Check and adjust travel	-	1
	1	Rear wheel support bear- ings	Lubricate	SPL	1
	11	Side brush guard	Rotate 90°	-	1
400 Hours	9	Front wheel bearings	Check, lubricate, and adjust	SPL	2
	6	Fuel filter	Replace cartridge	-	1
	17	Fuel tank	Remove sediment	-	1
	3	Cooling system	Flush	WG	1
800 Hours	2	Hydraulic reservoir	Replace hydraulic breather	-	1
			Replace suction strainer	-	1
			Change hydraulic fluid	HYDO	1
	5	Hydraulic fluid filter	Change filter element	-	1
	2	Hydraulic hoses	Check for wear and damage	-	31
	1	Propelling motor	*Torque shaft nut	-	1
	1	Rear wheel	*Torque wheel nuts	-	1
	16	Battery	*Clean and tighten battery cable connections	-	1

LUBRICANT/FLUID

EO Engine oil, SAE-CC/CD rated

HYDO . Tennant Company or approved hydraulic fluid

WG . . . Water and permanent-type ethylene glycol anti-freeze, -34° C (-30° F)

SPL . . . Special lubricant, Lubriplate EMB grease (TENNANT part no. 01433-1)

NOTE: Also check procedures indicated () after the first 50-hours of operation.*

LUBRICATION

ENGINE

Check the engine oil level daily. Change the engine oil and oil filter every 100 hours of machine operation. Use SAE-CC/CD rated engine oil.

The following recommended SAE-CC/CD rated oil grades are for use in engines during changing seasonal temperatures:

SINGLE AND MULTI-VISCOSITY OILS		
Below 32° F (Below 0° C)	32° to 77° F (0° to 25° C)	Above 77° F (Above 25° C)
10W	20	30
10W30		

Fill the engine with oil to the level indicated on the oil dipstick. Low oil level is indicated by the mark closest to the end of the dipstick. Full level is indicated by the mark closest to the top of the dipstick. The engine oil capacity is 6 L (6.35 qt) without the oil filter.

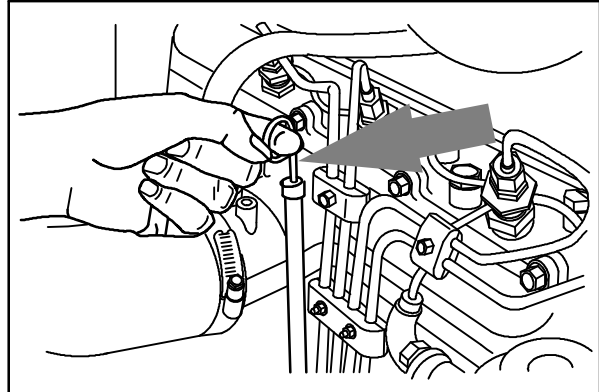

08431

REAR WHEEL SUPPORT

The rear wheel support pivots the rear wheel. The support has one grease fitting for the bearings. The rear wheel support bearings must be lubricated every 200 hours of operation. Use Lubriplate EMB grease (TENNANT part no. 01433-1).

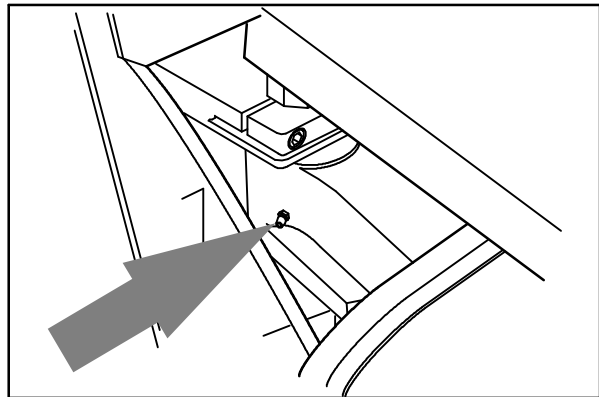

08005

FRONT WHEEL BEARINGS

Inspect the front wheel bearings for seal damage, and repack and adjust every 400 hours of operation. Use Lubriplate EMB grease (TENNANT part no. 01433-1).

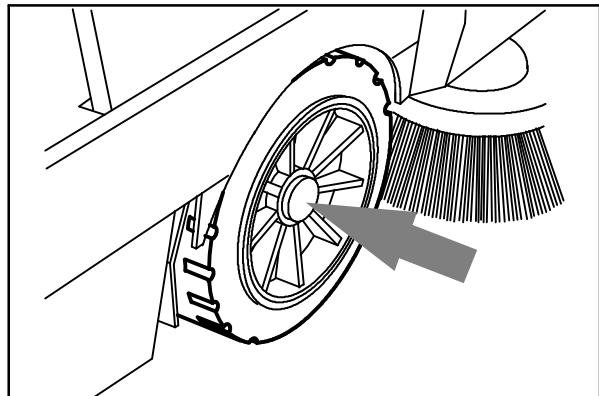

08006

HYDRAULICS

HYDRAULIC FLUID RESERVOIR

The reservoir is located in the engine compartment next to the radiator.

Mounted on top of the reservoir is a filler cap with a fluid level dipstick. The reservoir also has a hydraulic breather. On machines below serial number 003219, the breather is built into the filler cap. On machines serial number 003219 and above, the breather is located next to the filler cap. Replace the hydraulic breather after every 800 hours of operation.

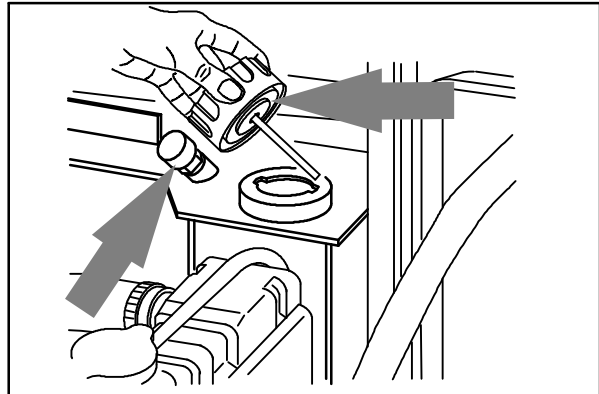

08007

Check the hydraulic fluid level at operating temperature every 100 hours of operation. Make sure the hopper is down when checking hydraulic fluid level. The end of the dipstick is marked with FULL and ADD levels to indicate the level of hydraulic fluid in the reservoir.

Lubricate the filler cap gasket with a film of hydraulic fluid before putting the cap back on the reservoir.

ATTENTION! Do not overfill the hydraulic fluid reservoir or operate the machine with a low level of hydraulic fluid in the reservoir. Damage to the machine hydraulic system may result.

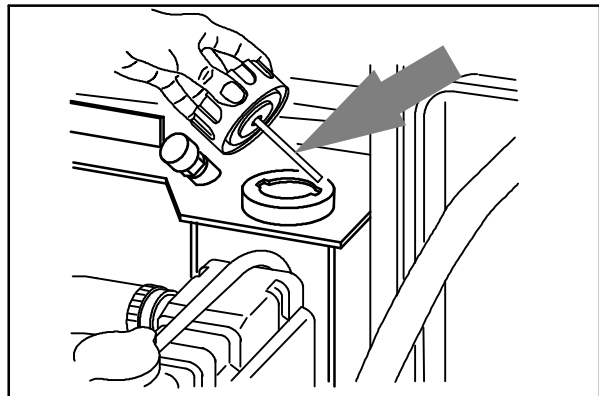

07750

Drain and refill the hydraulic fluid reservoir with new hydraulic fluid every 800 hours of operation.

The hydraulic fluid filter is located at the bottom of the engine compartment. Replace the filter element every 800 hours of operation.

The reservoir has a built-in strainer outlet that filters hydraulic fluid before it enters the system. Replace the strainer every 800 hours of operation.

HYDRAULIC FLUID

The quality and condition of the hydraulic fluid play a very important role in how well the machine operates. TENNANT's hydraulic fluid is specially selected to meet the needs of TENNANT machines.

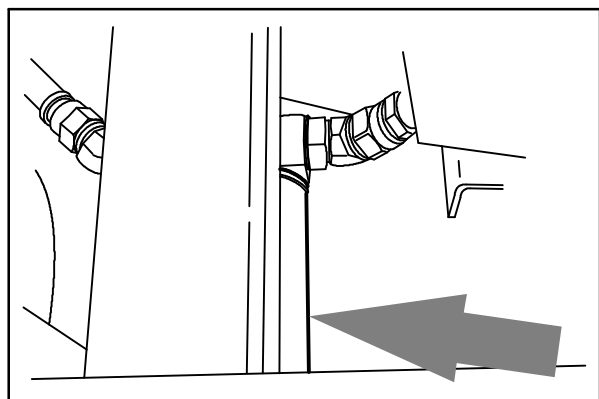

08051

MAINTENANCE

TENNANT's hydraulic fluids provide a longer life for the hydraulic components. There are two fluids available for different temperature ranges:

TENNANT part no.	Ambient Temperature
65869	above 7° C (45° F)
65870	below 7° C (45° F)

The higher temperature fluid has a higher viscosity and should not be used at the lower temperatures. Damage to the hydraulic pumps may occur because of improper lubrication.

The lower temperature fluid is a thinner fluid for colder temperatures.

If a locally-available hydraulic fluid is used, make sure the specifications match TENNANT hydraulic fluid specifications. Using substitute fluids can cause premature failure of hydraulic components.

European manufactured machines are filled with locally available hydraulic fluids. Check the label on the hydraulic fluid reservoir.

ATTENTION! Hydraulic components depend on system hydraulic fluid for internal lubrication. Malfunctions, accelerated wear, and damage will result if dirt or other contaminants enter the hydraulic system.

HYDRAULIC HOSES

Check the hydraulic hoses every 800 hours of operation for wear or damage.

Fluid escaping at high pressure from a very small hole can be almost invisible, and can cause serious injuries.

See a doctor at once if injury results from escaping hydraulic fluid. Serious infection or reaction can develop if proper medical treatment is not given immediately.

FOR SAFETY: When servicing machine, use cardboard to locate leaking hydraulic fluid under pressure.

If you discover a fluid leak, contact your mechanic/supervisor.

PROPELLING MOTOR

Torque the shaft nut to 270 Nm (200 ft lb) after the first 50-hours of operation, and every 800 hours there after.

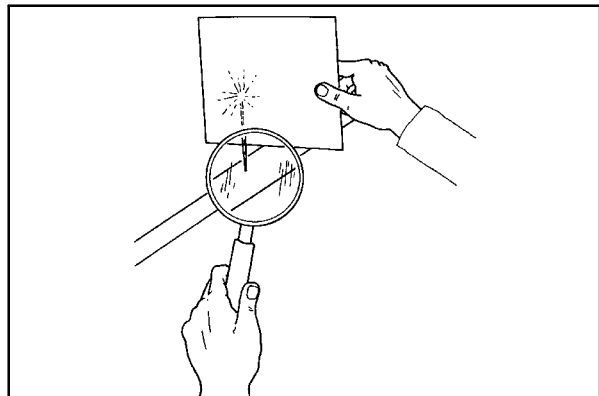

00002

ENGINE

COOLING SYSTEM

Check the radiator core exterior for debris every 100 hours of operation. Blow or rinse all dust, which may have collected on the radiator, in through the grille and radiator fins, opposite the direction of normal air flow. The grille and hydraulic cooler open for easier cleaning. Be careful not to bend the cooling fins when cleaning. Clean thoroughly to prevent the fins becoming encrusted with dust. Clean the radiator and cooler only after the radiator has cooled to avoid cracking.

FOR SAFETY: When servicing machine, wear eye and ear protection when using pressurized air or water.

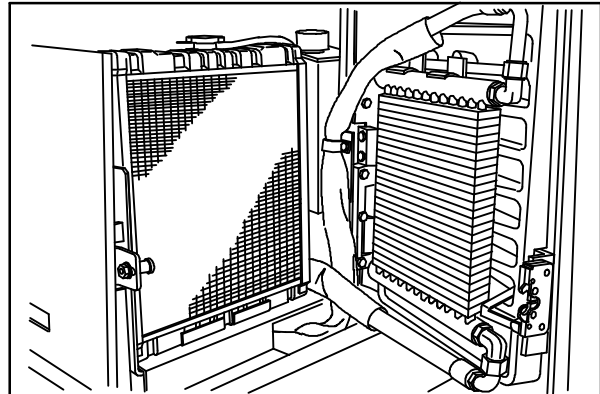

07809

Check the radiator coolant level every 100 hours of operation. Use clean water mixed with a permanent-type, ethylene glycol antifreeze to a -34°C (-30°F) rating.

FOR SAFETY: When servicing machine, avoid contact with hot engine coolant.

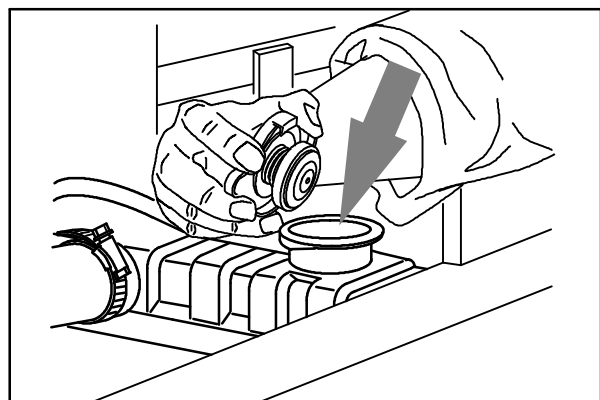

07752

Check the radiator hoses and clamps every 200 hours of operation. Tighten the clamps if they are loose. Replace the hoses and clamps if the hoses are cracked, harden, or swollen.

Flush the radiator and the cooling system every 800 hours of operation, using a dependable cleaning compound.

MAINTENANCE

AIR FILTER INDICATOR

The air filter indicator shows when to clean or replace the air filter element. Check the indicator daily. The indicator's red line will move as the air filter element fills with dirt. Do not clean or replace the air filter element until the red line reaches 5 kPa (20 in H₂O) and the "SERVICE WHEN RED" window is filled with red. The indicator's red line may return to a lower reading on the scale when the engine shuts off. The red line will return to a correct reading after the engine runs for a while.

Reset the air filter indicator by pushing the reset button on the end of the indicator after cleaning or replacing the air filter element.

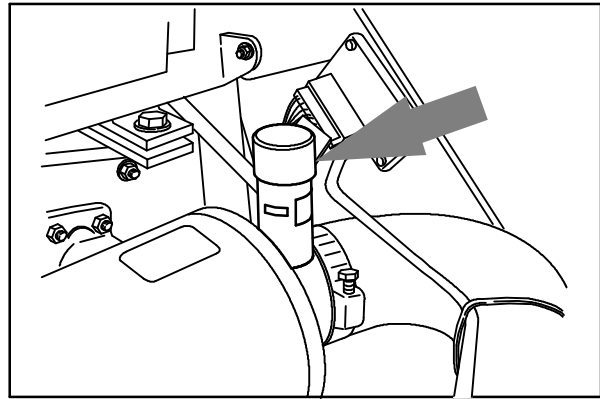

07808

AIR FILTER

The engine air filter housing has a dust cap and a dry cartridge-type air filter element. Empty the dust cap daily. The air filter must be replaced whenever the filter element is damaged or has been cleaned three times.

Machines with the heavy duty air filter option have a safety element. It is inside the standard element. Replace this element, do not clean it, after the regular element has been damaged or cleaned three times.

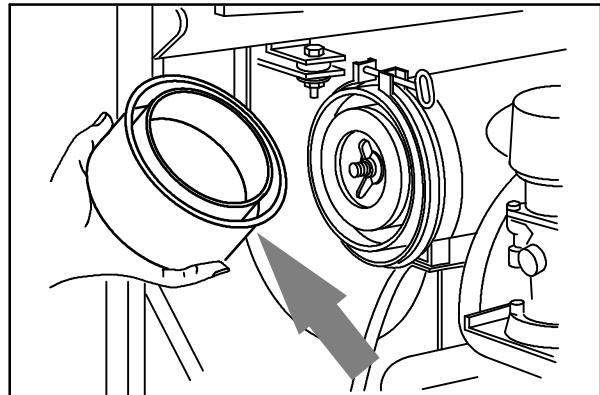

08008

Install the dust cap on the air filter housing with the arrows pointing up.

Service the air filter element only when the air filter indicator shows restriction in the air intake system. Do not remove the air filter element from the housing unless it is restricting air flow.

To clean the filter element, remove it from the filter housing. Carefully clean the end cap and the interior of the housing with a damp cloth. Clean the housing sealing surfaces.

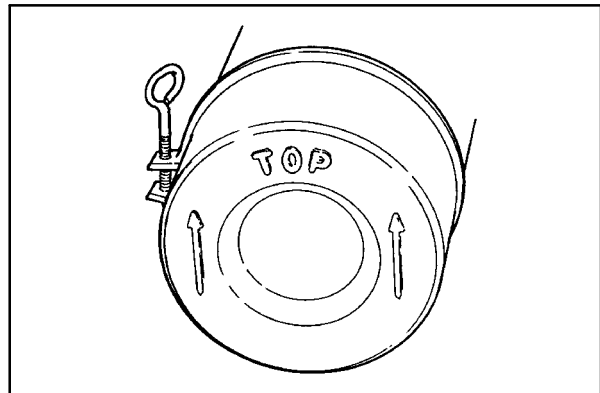

02492

Using an air hose, direct clean dry air, maximum 205 kPa (30 psi), up and down the pleats on the inside of the element. Do not rap, tap or pound dust out of the element.

FOR SAFETY: When servicing machine, wear eye and ear protection when using pressurized air or water.

After cleaning the air filter element, inspect it for damage by placing a bright light inside. The slightest rupture requires replacement of the element. Inspect the seals on the ends of the element, they should be flexible and undamaged.

FUEL FILTER

The fuel filter cartridge filters impurities from the fuel. It is located on the left side of the engine.

Replace the fuel filter element every 400 hours of operation.

FOR SAFETY: When servicing machine, keep flames and sparks away from fuel system service area. Keep area well ventilated.

FUEL PIPES

Check the fuel pipes every 50 hours of operation. If the clamp band is loose, apply oil to the screw of the band, and securely tighten the band.

Made of rubber, the fuel pipes become worn out whether the engine has been used much or not. Replace the fuel pipes and clamp bands every two years.

If the fuel pipes and clamp bands are found worn or damaged before two years' time, replace or repair them at once. Bleed the fuel system after replacement of any of the fuel pipes, see *TO PRIME THE FUEL SYSTEM*. When the fuel pipes are not installed, plug both ends with clean cloth or paper to prevent dirt from entering the pipes. Dirt in the pipes can cause fuel injection pump malfunction.

PRIMING FUEL SYSTEM

Typical diesel fuel systems require priming to remove pockets of air in the fuel lines and fuel components. This is usually required after running out of fuel, changing fuel filter elements or repairing a fuel system component. Air in the fuel system prevents smooth engine operation.

This fuel system however is self-priming. The return line comes from the top of the injector which causes all air to escape through the return line.

BATTERY

The battery for the machine is a low maintenance battery. Do not add water to the battery or remove the battery vent plugs.

After the first 50 hours of operation, and every 800 hours after that, clean and tighten the battery connections.

For Safety: When servicing machine, avoid contact with battery acid.

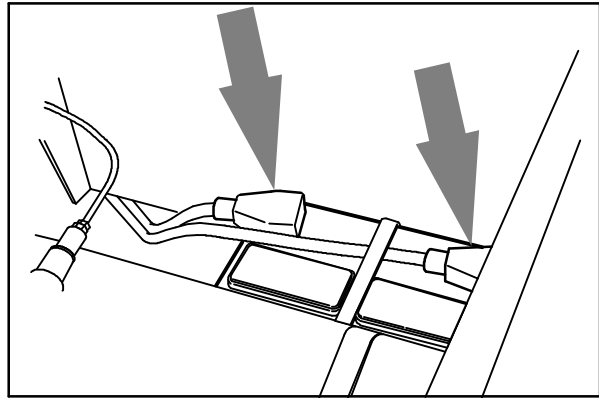

08050

BELTS AND CHAINS

ENGINE FAN BELT

The engine fan belt is driven by the engine crankshaft pulley and drives the engine fan and alternator pulleys. Proper belt tension is obtained when the belt deflects 7 to 9 mm (0.28 to 0.35 in) from a force of 10 kg (22 lb) applied at the mid-point of the longest span.

Check and adjust the belt tension every 100 hours of operation.

 **WARNING: Moving belt and fan. Keep away.**

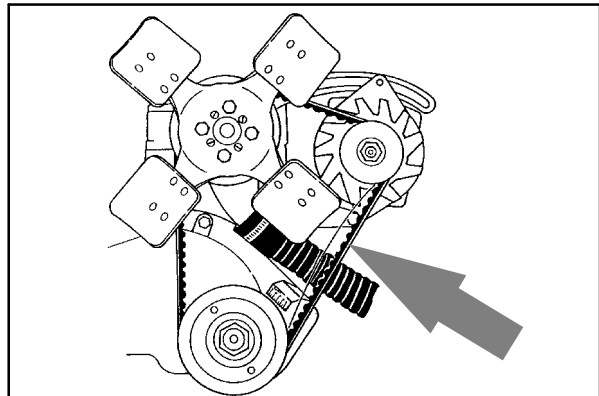

00577

STATIC DRAG CHAIN

A static drag chain prevents the buildup of static electricity in the machine. The chain is attached to the machine by a rear main brush skirt retaining bolt.

Make sure the chain is touching the floor at all times.

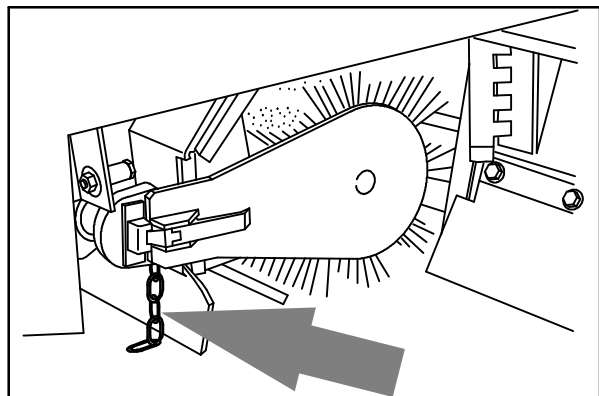

08009

DEBRIS HOPPER

HOPPER DUST FILTER

The dust filter filters the air pulled up from the hopper. The dust filter is equipped with a shaker to remove the accumulated dust particles. The dust filter shaker is operated by the filter shaker switch.

Shake the dust filter before emptying the hopper and at the end of every work shift. Check and clean or replace the dust filter every 100 hours of operation.

To clean the dust filter, use one of the following methods:

- **SHAKING** - Press the filter shaker switch.
- **TAPPING** - Tap the filter gently on a flat surface with the dirty side down. Do not damage the edges of the filter element or the filter will not seat properly in the filter frame.
- **AIR** - Blow air through the dust filter opposite the direction of the arrows. This may be done with the dust filter in the machine. Always wear eye protection when using compressed air.

FOR SAFETY: When servicing machine, wear eye and ear protection when using pressurized air or water.

- **WATER** - Soak the dust filter in a water and mild detergent solution. Rinse the dust filter until it is clean. Air dry the wet dust filter; do not use compressed air.

NOTE: Be sure the dust filter is dry before reinstalling it in the machine.

TO REPLACE HOPPER DUST FILTER

1. Stop the engine and set the machine parking brake.

FOR SAFETY: Before leaving or servicing machine; stop on level surface, set parking brake, turn off machine and remove key.

2. Open the hopper cover.

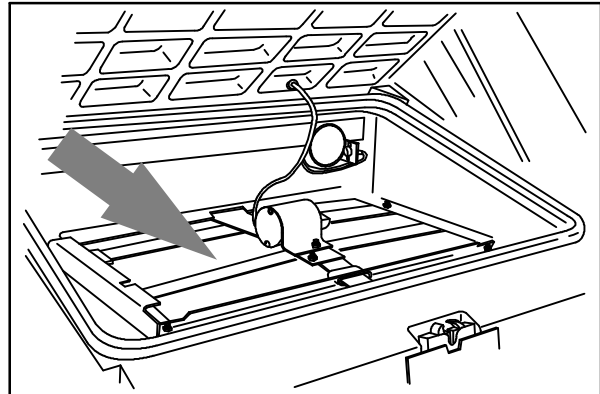

08010

MAINTENANCE

3. Disconnect the shaker motor wire connectors.

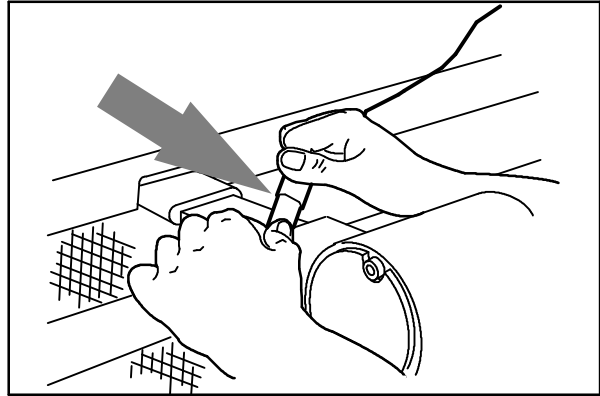

08011

4. Remove the four retaining nuts from the filter shaker frame.
5. Pull the filter shaker frame out of the hopper.

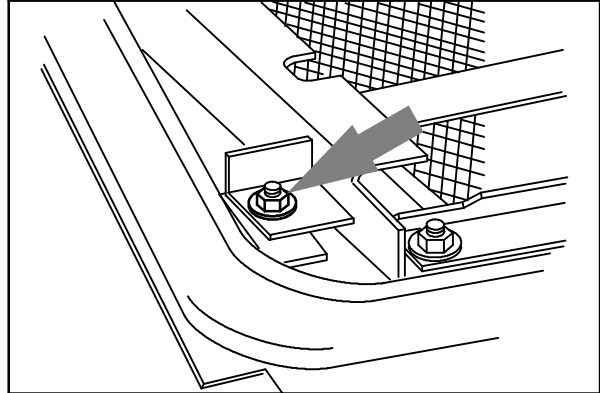

08014

6. Lift the dust filter element out of the hopper insert.
7. Clean or discard the dust filter as required.

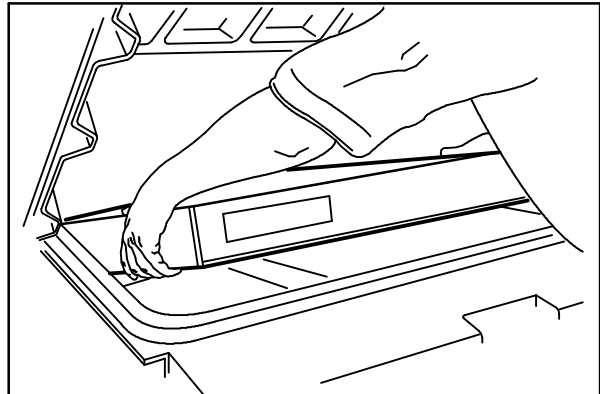

08012

8. Put the cleaned or new dust filter in the hopper insert with the arrows pointing up.
9. Put the shaker frame on top of the panel filter.
10. Install the four retaining nuts and tighten.
11. Connect the shaker motor wire connectors.

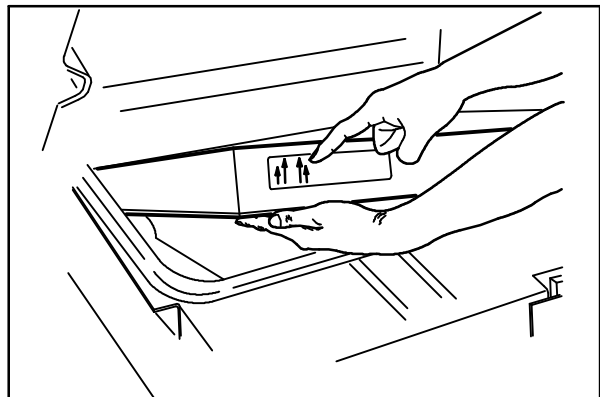

08013

THERMO SENTRY™

The Thermo Sentry™ senses the temperature of the air pulled up from the hopper. If there is a fire in the hopper, the Thermo Sentry™ stops the vacuum fan and cuts off the air flow.

Reset the Thermo Sentry™ by pushing in its reset button.

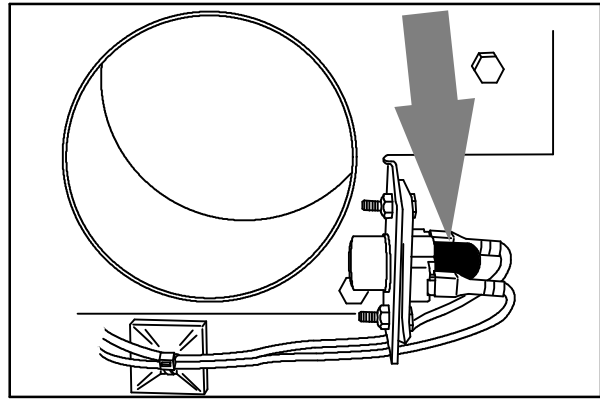

08015

BRUSHES

MAIN BRUSH

The main brush is cylindrical and spans the width of the machine, sweeping debris into the hopper.

Check the brush daily for wear or damage. Remove any string or wire tangled on the main brush, main brush drive hub, or main brush idler hub.

Check the main brush pattern daily. The pattern should be 50 to 65 mm (2.0 to 2.5 in) wide with the main brush in the **Down** position. Adjust the main brush pattern by turning the main brush pressure knob located next to the brush position lever.

Rotate the main brush end-for-end every 50 hours of operation for maximum brush life and best sweeping performance.

Replace the main brush when the remaining bristles measure 30 mm (1.25 in) in length.

MAINTENANCE

TO REPLACE MAIN BRUSH

1. Stop the engine and set the machine parking brake.

FOR SAFETY: Before leaving or servicing machine; stop on level surface, set parking brake, turn off machine and remove key.

2. Raise the main brush.
3. Open the right side main brush access door.
4. Unlatch and remove the brush idler plate.

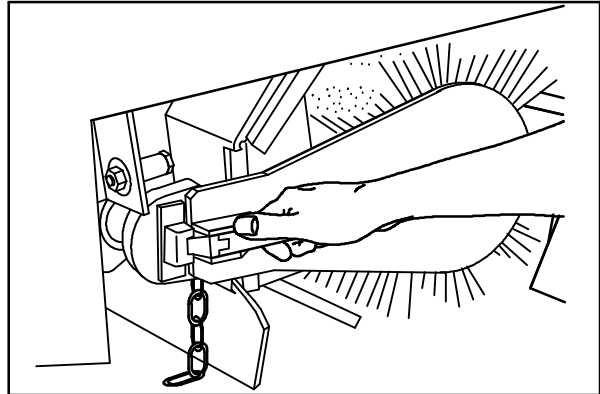

08016

5. Grasp the main brush; pull it off the brush drive plug and out of the main brush compartment.
6. Put the new or rotated end-for-end main brush on the floor next to the access door.
7. Slide the main brush onto the drive plug. Rotate the brush until it engages the drive plug, and push it all the way onto the plug.
8. Slide the main brush idler plate plug onto the main brush.
9. Latch the idler plate onto the machine frame.
10. Close the right side main brush access door.

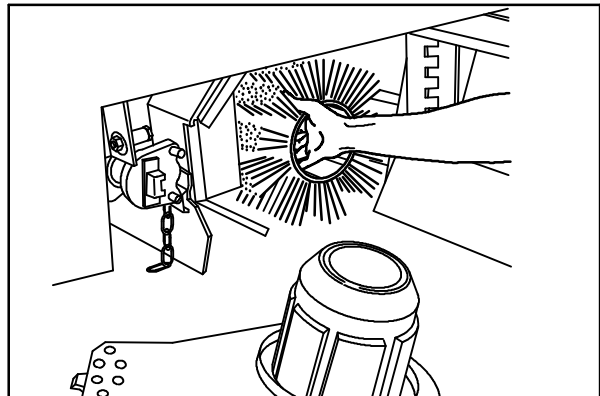

08017

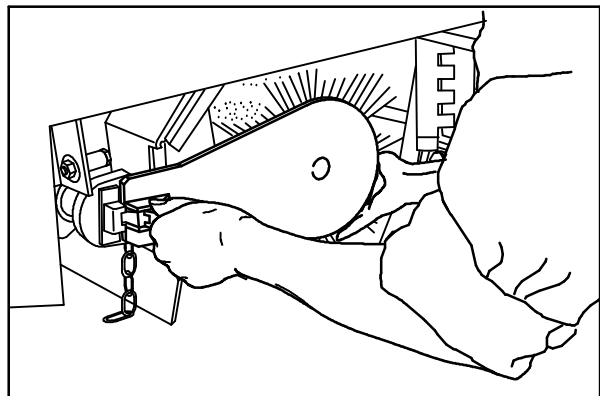

08018

TO CHECK AND ADJUST MAIN BRUSH PATTERN

1. Apply chalk, or some other material that will not blow away easily, to a smooth, level floor.
2. Raise the side brush and main brush and position the main brush over the chalked area.
3. Start the main brush.
4. Lower the main brush for 15 to 20 seconds while keeping a foot on the brakes to keep the machine from moving. This will lower the rotating main brush.

NOTE: If chalk or other material is not available, allow the brushes to spin on the floor for two minutes. A polish mark will remain on the floor.

5. Raise the main brush.
6. Stop the main brush.
7. Drive the machine off the test area.
8. Observe the width of the brush pattern. The proper brush pattern width is 50 to 65 mm (2.0 to 2.5 in).

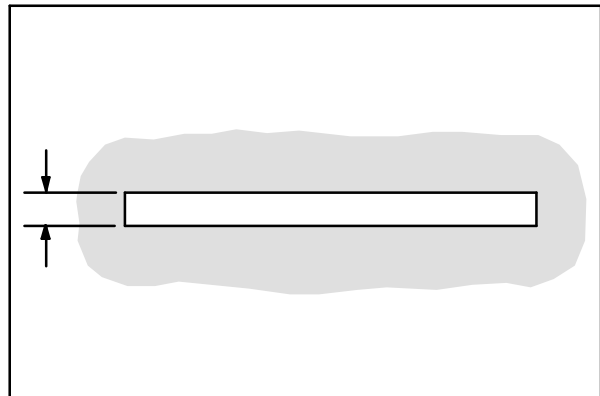

00582

9. To increase the width of the main brush pattern, turn the main brush down pressure knob counter-clockwise.

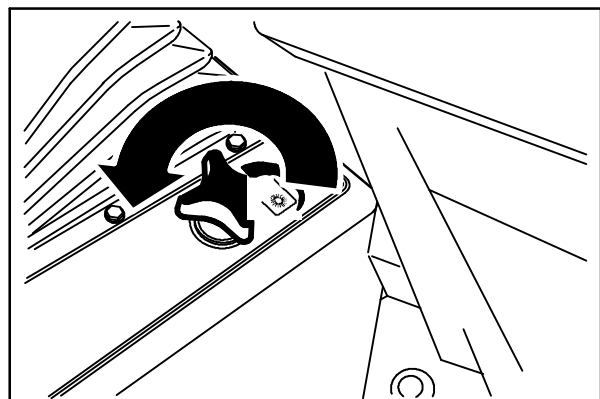

07787

MAINTENANCE

To decrease the width of the main brush pattern, turn the main brush down pressure knob clockwise.

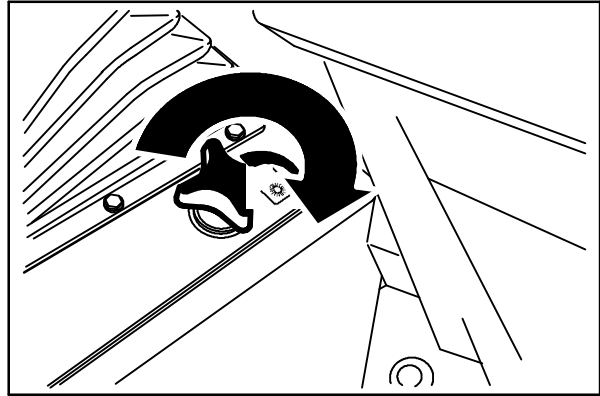

07788

If the main brush pattern is tapered, more than 15 mm (0.5 in) on one end than the other, adjust the taper with the taper adjustment bracket at the drive end of the brush.

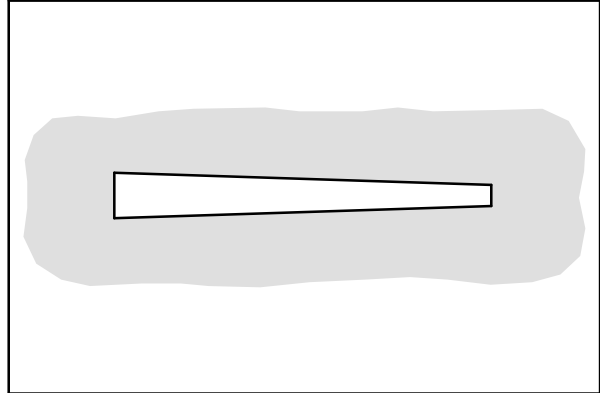

00601

A. Loosen the bracket mounting bolts.

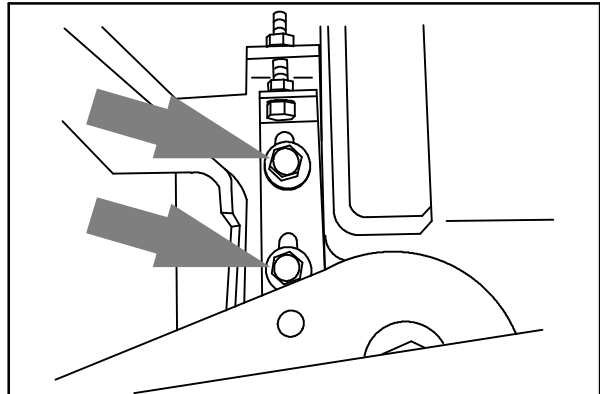

08216

B. Turn the taper adjustment nut counter-clockwise to increase the pattern width at the brush drive end, and clockwise to decrease the pattern width at the brush drive end. Tighten the mounting bolts.

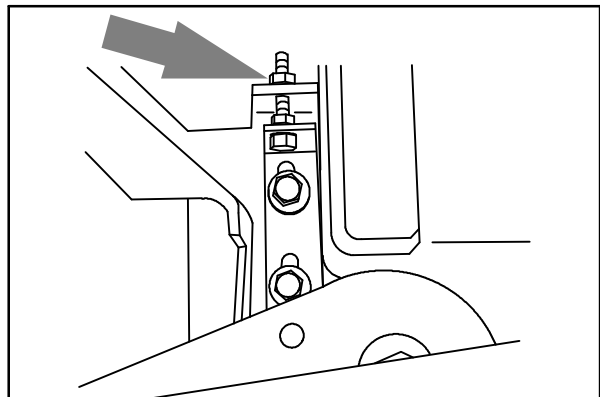

08215

C. Check the main brush pattern and readjust as necessary. Then adjust the width of the main brush pattern.

SIDE BRUSH

The side brush sweeps debris along edges into the path of the main brush.

Check the brush daily for wear or damage. Remove any string or wire found tangled on the side brush or side brush drive hub.

Check the side brush pattern daily. One-half of the side brush bristles should contact the floor when the brush is in motion. Adjust the side brush pattern by the side brush down pressure knob. Turn the knob counter-clockwise to increase the brush contact with the sweeping surface, and clockwise to decrease the brush contact with the sweeping surface.

The side brush should be replaced when it no longer sweeps effectively for your application. A guideline length is when the remaining bristles measure 50 mm (2 in) in length. You may change the side brush sooner if you are sweeping light litter, or wear the bristles shorter if you are sweeping heavy debris.

MAINTENANCE

TO REPLACE SIDE BRUSH

1. Empty the debris hopper.
2. Set the machine parking brake.
3. Stop the engine.

FOR SAFETY: Before leaving or servicing machine; stop on level surface, set parking brake, turn off machine and remove key.

4. Raise the side brush.
5. Remove the side brush retaining pin from the side brush drive shaft by pulling the pin keeper off over the end of the pin.
6. Slide the side brush off the side brush drive shaft.

NOTE: Remove the drive hub and put it on the new brush if one is not installed.

7. Slide the new side brush onto the side brush drive shaft.
8. Insert the side brush retaining pin through the side brush hub and shaft.
9. Secure the pin by clipping the pin keeper over the end of the pin.
10. Disengage the hopper support bar and lower the hopper.
11. Adjust the side brush pattern with the side brush down pressure knob.

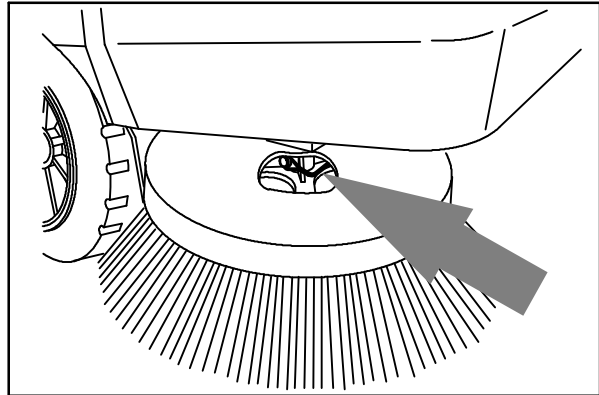

08019

SIDE BRUSH GUARD

Rotate the side brush guard 90° every 200 hours of operation. Replace the brush guard after all four sides have been used.

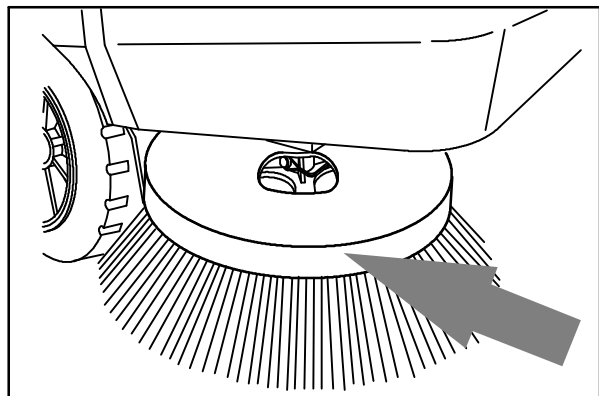

08049

SKIRTS AND SEALS

HOPPER LIP SKIRTS

The hopper lip skirts are located on the bottom rear of the hopper. The skirts float over debris and help deflect that debris into the hopper. The hopper lip skirts consist of five bottom lip segments and two additional side lip segments.

Check the hopper lip skirts for wear or damage daily.

Replace the hopper lip skirts when they no longer touch the floor.

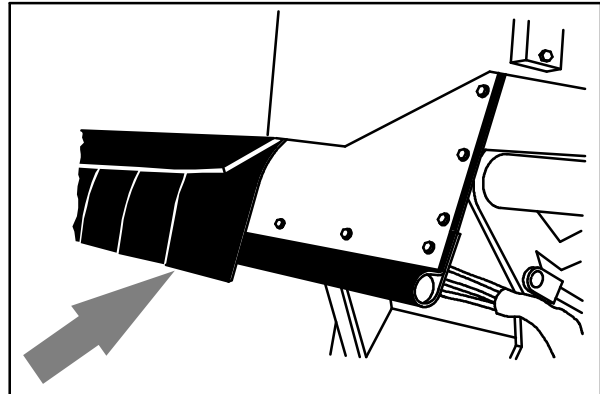

08020

HOPPER SIDE SKIRT

The hopper side skirt is located on the left side of the hopper.

Check the hopper side skirt for wear or damage daily.

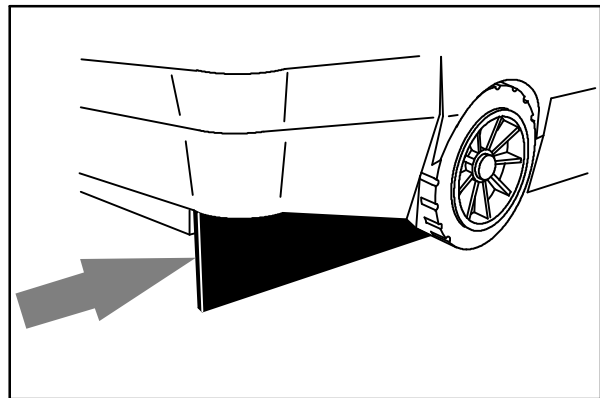

08214

BRUSH DOOR SKIRTS

The brush door skirts are located on the bottom of each of the two main brush doors. The long skirt should clear the floor by 3 to 6 mm (0.12 to 0.25 in). The inner skirt should be angled so that the rear corner touches the floor, and the front corner is 6 mm (0.25 in) above the corner of the long skirt.

Check the skirts for wear or damage and adjustment daily.

NOTE: The brush door skirts have slotted holes to allow for a ground clearance adjustment. The door must be closed for proper adjustment.

NOTE: Rear tire pressure will affect skirt clearances.

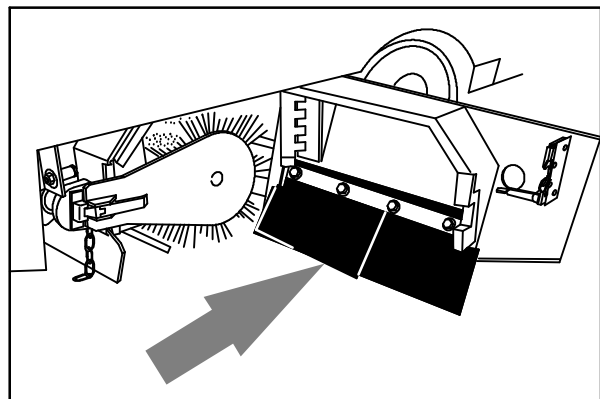

08001

MAINTENANCE

REAR SKIRTS

The two rear skirts are located on the bottom rear of the main brush compartment. The vertical skirt should clear the floor up to 5 mm (0.25 in) in dusty conditions, and touch the floor otherwise. The recirculation skirt is self-adjusting.

Check the skirts for wear or damage and adjustment daily.

NOTE: Rear tire pressure will affect skirt clearances.

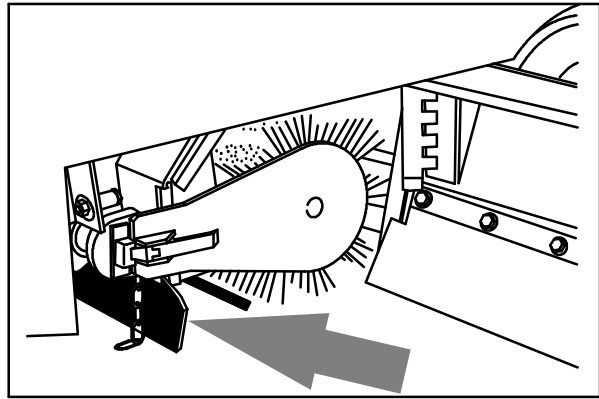

08021

SIDE BRUSH DUST CONTROL SKIRTS (OPTION)

The side brush dust control skirt wrap around the side brush and the bottom of the hopper.

Check the side brush dust control skirts for wear or damage daily.

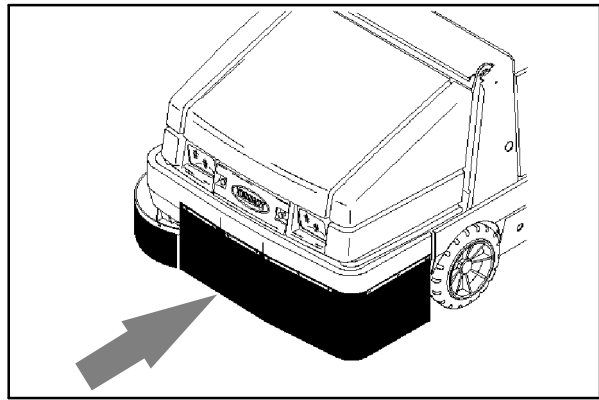

08213

BRUSH DOOR SEALS

The brush door seals are located on both main brush doors and on corresponding portions of the main frame.

Check the seals for wear or damage every 100 hours of operation.

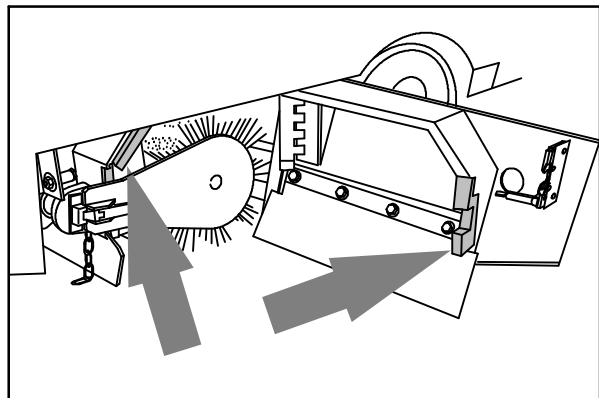

08022

HOPPER SEALS

The hopper seals are located on the top and side portions of the machine frame that contact the hopper.

Check the seals for wear or damage every 100 hours of operation.

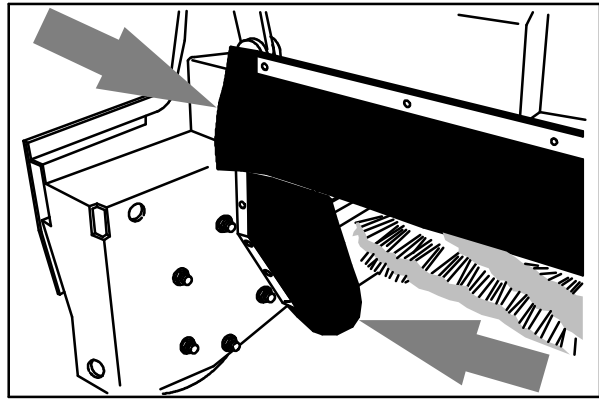

08023

HOPPER INSPECTION DOOR SEAL

The hopper inspection door seal is located on the hopper and seals the front of the debris hopper.

Check the seal for wear or damage every 100 hours of operation.

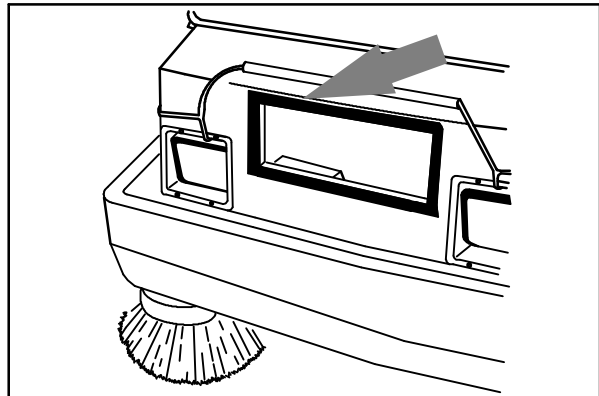

08024

HOPPER DOOR SEALS

The hopper door seals are located on the hopper door. They seal the hopper when the hopper door is closed.

Check the seals for wear or damage every 100 hours of operation.

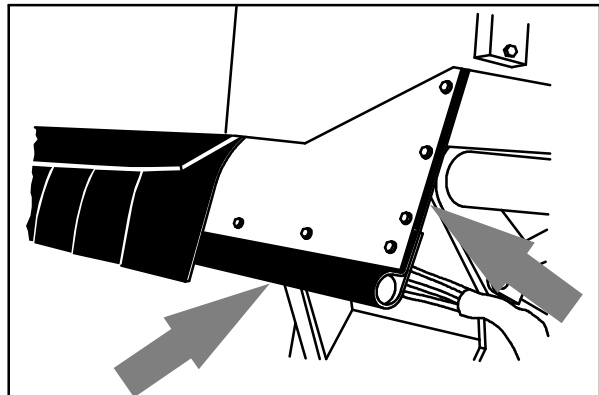

08025

MAINTENANCE

HOPPER COVER SEAL

The hopper cover seal is located on the top edges of the hopper insert. It seals the hopper filter compartment.

Check the seal for wear or damage every 100 hours of operation.

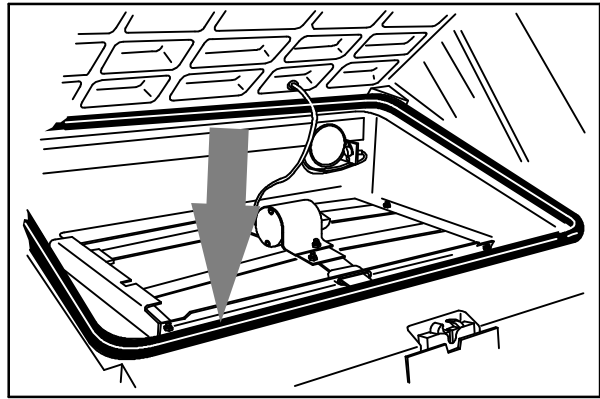

08026

HOPPER DUST SEAL

The hopper dust seal is located under the hopper insert along the top of the hopper.

Check the seal for wear or damage every 100 hours of operation. You can reach the seal by removing the hopper insert.

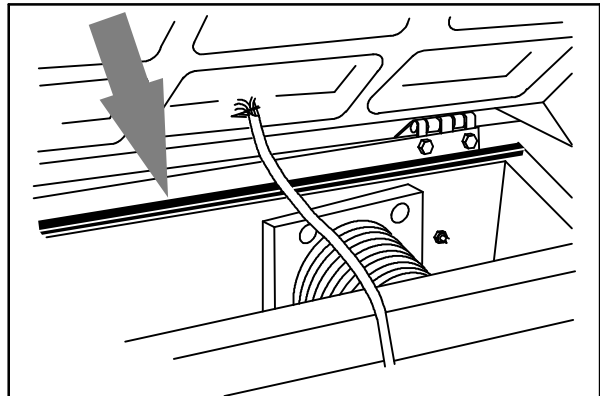

08153

HOPPER VACUUM FAN SEAL

The hopper vacuum fan seal is mounted on the inside of the hopper around the vacuum fan inlet.

Check the seal for wear or damage every 100 hours of operation. You can reach the seal by removing the hopper insert.

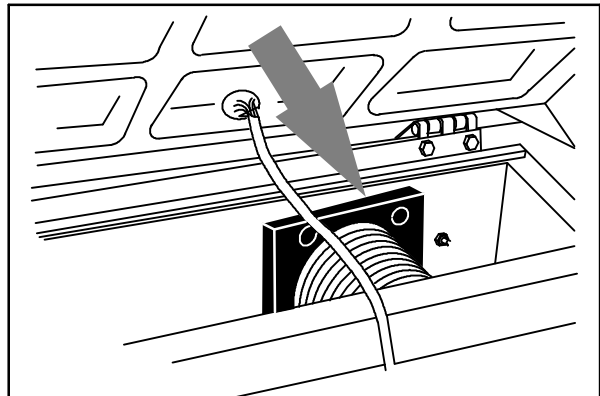

08150

BRAKES AND TIRES

SERVICE BRAKES

The mechanical service brakes are located on the front wheels. The brakes are operated by the foot brake pedal and connecting cables.

Check the brake adjustment every 200 hours of operation. The brake pedal should not travel more than 25 mm (1 in) to fully engage the brakes.

PARKING BRAKE

The parking brake is set with the parking brake lever that activates the service brakes.

Adjust the parking brake whenever it becomes very easy to set the parking brake, when the machine rolls after setting the parking brake, and every 200 hours of operation. The parking brake may be tightened by turning the knurled knob on the end of the parking brake clockwise.

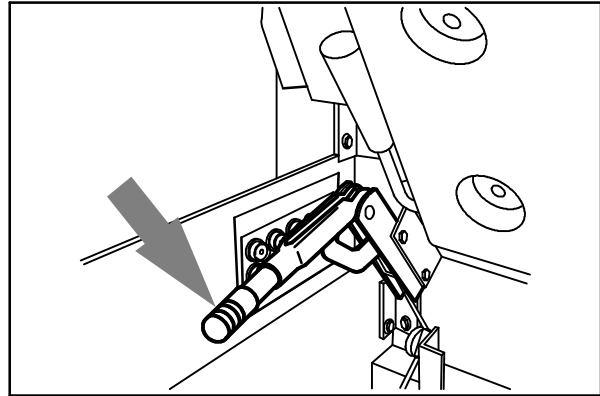

08053

TIRES

The standard front machine tires are solid. The standard rear machine tire is pneumatic.

Check the rear tire pressure every 100 hours of operation. The proper tire air pressure is 790 ± 35 kPa (115 ± 5 psi).

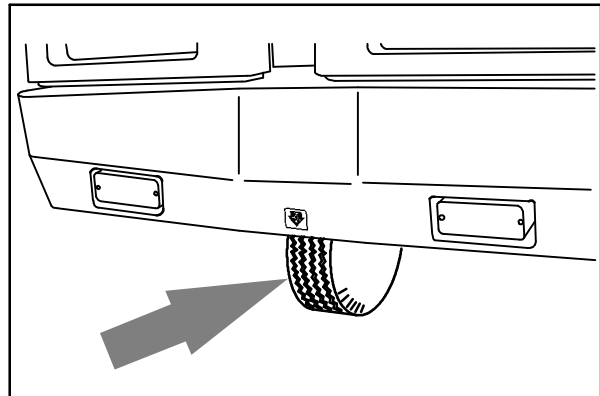

08028

REAR WHEEL

Torque the rear wheel nuts in a star pattern to 122 to 150 Nm (90 to 110 ft lb) after the first 50-hours of operation, and every 800 hours there after.

PUSHING OR TOWING MACHINE

The machine can be pushed from the front or rear. Tow it only from the rear. On machines below serial number 002436, the machine must be towed with a dolly placed under the rear wheel.

ATTENTION! Do not push or tow the machine (below serial number 002436) without placing the rear wheel on a dolly or the machine hydraulic system may be damaged.

On machines serial number 002436 and above, there is a towing valve on the propelling pump. This valve prevents damage to the hydraulic system when the machine is being towed. Turn the valve 90° clockwise before towing the machine.

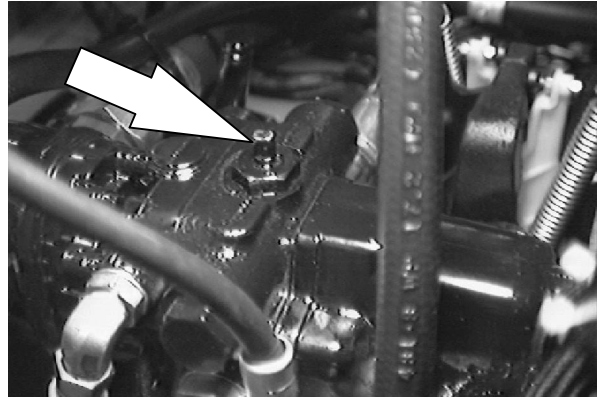

MACHINE JACKING

You can jack up the machine for service at the designated locations. Use a jack of adequate capacity and good working condition. Always stop the machine on a flat, level surface and block the tires before jacking the machine up.

The front jacking locations are on the flat bottom edge of the front of the machine frame next to the front tires.

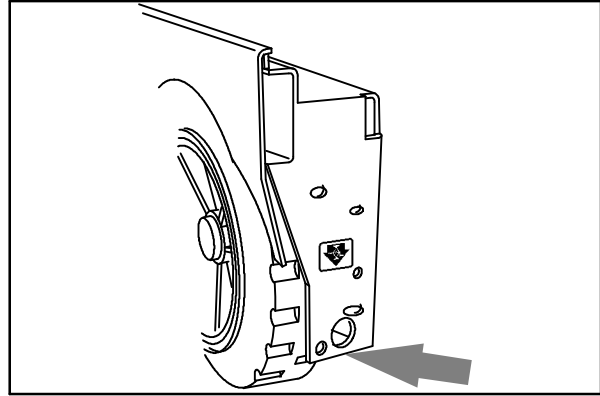

08029

The rear jacking location is the middle flat bottom edge of the rear bumper between the taillights.

For Safety: When servicing machine, block machine tires before jacking machine up.

FOR SAFETY: When servicing machine, jack machine up at designated locations only. Block machine up with jack stands.

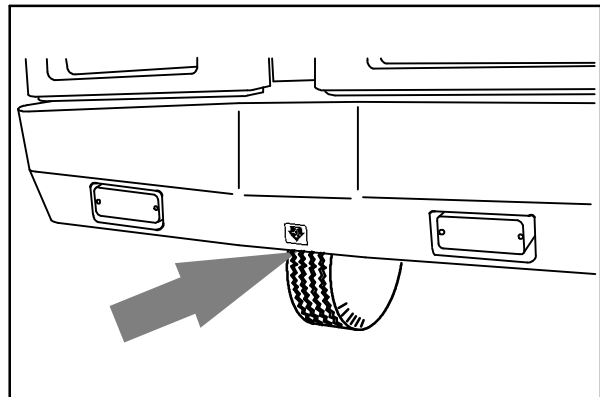

08030

STORING MACHINE

Before storing the machine for an extended period of time, the machine needs to be prepped to lessen the chance of rust, sludge, and other undesirable deposits from forming. Contact TENNANT service personnel.

SPECIFICATIONS

SPECIFICATIONS

GENERAL MACHINE DIMENSIONS/CAPACITIES

Item	Dimension/capacity
Length	2360 mm (93 in)
Width	1590 mm (62.5 in)
Height	1475 mm (58 in)
Height with overhead guard	2080 mm (82 in)
Height with overhead guard and hazard light	2270 mm (89.5 in)
Height with cab	2100 mm (82.62 in)
Height with cab and hazard light	2285 mm (90 in)
Track	1345 mm (53 in)
Wheelbase	1135 mm (44.75 in)
Main brush diameter	355 mm (14 in)
Main brush length	1145 mm (45 in)
Side brush diameter	585 mm (23 in)
Sweeping path width	1145 mm (45 in)
Sweeping path width with side brush	1525 mm (60 in)
Main brush pattern width	50 to 65 mm (2.0 to 2.5 in)
Hopper weight capacity	545 kg (1200 lb)
Hopper volume capacity	396 L (14 cu ft)
Dust filter area	6.9 m ² (74 sq ft)
GVWR	1927 kg (4250 lb)
Sound level	80 dBa
Ceiling height minimum dumping clearance	2745 mm (9 ft)

GENERAL MACHINE PERFORMANCE

Item	Measure
Maximum forward speed	13.7 kmh (8.5 mph)
Maximum reverse speed	4.0 kmh (2.5 mph)
Minimum aisle turn width, left	2870 mm (113 in)
Minimum aisle turn width, right	4725 mm (186 in)
Maximum rated climb and descent angle	6°

POWER TYPE

Engine	Type	Ignition	Cycle	Aspiration	Cylinders	Bore	Stroke
Kubota V1505-B	Piston	Diesel	4	Natural	4	78 mm (3.07 in)	78.4 mm (3.08 in)
	Displacement		Net power, governed		Net power, maximum		
	1500 cc (91.4 cu in)		24.6 kw (34 hp) @ 2400 rpm		27.2 kw (37.5 hp) @ 3000 rpm		
	Fuel		Cooling system		Electrical system		
	Diesel Fuel tank: 36 L (9.6 gal)		Water/ethylene glycol antifreeze		12 V nominal		
			Total: 4.5 L (1.2 gal)		37 A alternator		
			Radiator: 3.8 L (1 gal)				
	Idle speed, no load		(Fast 1) governed speed, under load		(Fast 2) governed speed, under load		
	950 ± 50 rpm		2000 ± 50 rpm		2400 ± 50 rpm		
	Engine lubricating oil without filter						
6 L (6.35 qt) SAE-CC/CD rated engine oil							

STEERING

Type	Power source	Emergency steering
Rear wheel, hydraulic cylinder and rotary valve controlled	Hydraulic accessory pump	Manual

HYDRAULIC SYSTEM

System	Capacity	Fluid Type
Hydraulic reservoir	24.6 L (6.5 gal)	TENNANT part no. 65869 - above 7° C (45° F)
Hydraulic total	N/A L (N/A gal)	TENNANT part no. 65870 - below 7° C (45° F)

BRAKING SYSTEM

Type	Operation
Service brakes	Mechanical drum brakes (2), one per front wheel, cable actuated
Parking brake	Utilize service brakes, cable actuated

TIRES

Location	Type	Size	Pressure
Front (2)	Solid	5 x 18 in	-
Rear (1)	Pneumatic	6 x 19 in	790 ± 35 kPa (115 ± 5 psi)

INDEX**A**

Air filter, 62
 Dust cap, 62
 Element, 62
 Heavy duty filter option, 62
Air filter indicator, 62
Aisle turn, 80

B

Battery, 64
 Charging system, Light, 19
Bearings, Front wheel, 58
Belts, 64
 Engine fan belt, 64
Blower wand, 51–52
Brake pedal, 12
Brakes, 31, 77
 Parking, Adjustment, 77
 Service, 77
 System specifications, 81
Brushes, 34–35, 41, 67–71
 Adjusting main brush taper, 70–72
 Checking main brush pattern, 69–71
 Checking side brush pattern, 71
 Door latch, 27
 Door seals, 74
 Door skirts, 73
 Main brush, 67–70
 Main brush bristle length, 67
 Replacing main brush, 68–69
 Replacing side brush, 72
 Side brush, 71–72
 Side brush bristle length, 71
Button, Horn, 13

C

Cab
 Dome light switch, 29
 Door latch, 27
 Heater switch, 29
 Pressurizer switch, 29
 Windshield wiper switch, 29
Capacities, 80
Chains, 64
 Static drag, 64
Charging system light, 19
Circuit breakers, 26
Clogged filter light, 19
Control panel
 Clogged filter light, 19
 Engine oil pressure, 19
 Engine speed switch, 22
 Engine water temperature light, 18
 Filter shaker switch, 23
 Fuel level gauge, 20
 Hazard light switch, 21
 Hopper door light, 19
 Hopper temperature light, 18
 Hourmeter, 20
 Operating lights switch, 21
 Vacuum fan switch, 21
Controls, 10
 Brake pedal, 12
 Charging system light, 19
 Circuit breakers, 26
 Clogged filter light, 19
 Directional pedal, 11
 Dome light switch, 29
 Engine oil pressure light, 19
 Engine speed switch, 22
 Engine water temperature light, 18
 Filter shaker switch, 23
 Fuel level gauge, 20
 Fuse, 26
 Hazard light switch, 21
 Heater switch, 29
 Hopper door lever, 14
 Hopper door light, 19
 Hopper lift lever, 15
 Hopper temperature light, 18
 Horn button, 13
 Hourmeter, 20
 Ignition switch, 24
 Latches, 27

Main brush and side brush lever, 13
 Main brush down pressure knob, 17
 Main brush position lever, 16
 Operating lights switch, 21
 Operation, 11–29
 Parking brake lever, 12
 Pressurizer switch, 29
 Side brush down pressure knob, 25
 Side brush position lever, 25
 Steering column tilt lever, 23
 Steering wheel, 23
 Symbols, 8–9
 Turn signal switch, 17
 Vacuum fan switch, 21
 Windshield wiper switch, 29

Covers

Engine, Latch, 27
 Hopper
 Latch, 27
 Seals, 76

D

Debris hopper, 65–67
 Dimensions, 80
 Directional pedal, 11
 Disengaging hopper support bar, 43–44
 Dome light switch, 29
Doors
 Brush
 Latch, 27
 Seals, 74
 Skirts, 73
 Cab, Latch, 27
 Engine side, Latch, 27
 Grille, Latch, 27
 Hopper, Seals, 75
 Hopper Inspection, Seal, 75
Dust filter, 65–67
 Changing, 65–66
 Cleaning, 65

E

Electrical
 Circuit breakers, 26
 Fuse, 26
 Ignition switch, 24
 Emptying the hopper, 38–39
 Engaging hopper support bar, 42–43
Engine, 61–63
 Air filter, 62
 Air filter indicator, 30, 62
 Coolant temperature, Light, 18
 Cooling system, 61
 Cover latch, 27
 Fan belt, 64
 Fuel filter, 63
 Fuel pipes, 63
 Lubrication, 58
 Oil capacity, 58
 Oil level, 5, 31
 Oil pressure, Light, 19
 Priming fuel system, 63
 Side door latch, 27
 Specifications, 81
 Speed switch, 22
 Engine oil pressure light, 19
 Engine speed switch, 22
 Engine water temperature light, 18

F

Filter shaker switch, 23
 Fuel filter, 63
 Fuel level, 31
 Fuel level gauge, 20
 Fuel pipes, 63
Fuel system
 Fuel pipes, 63
 Priming, 63
 Fuel tank, 6
 Fuse, 26

G

Gauge, Fuel level, 20
 Grease fittings, Rear wheel support, 58

SPECIFICATIONS

H

Hazard light switch, 21
Heater switch, 29
Heater valve, 54
Hopper, 65–67
 Changing dust filter, 65–66
 Clogged filter, Light, 19
 Cover latch, 27
 Cover seal, 76
 Disengaging hopper support bar, 43–44
 Door lever, 14
 Door light, 19
 Door seals, 75
 Dust filter, 65–67
 Dust seal, 76
 Engaging hopper support bar, 42–43
 Filter cleaning, 65
 Filter shaker, 23
 Inspection door seal, 75
 Lift, 15
 Lip skirts, 73
 Seals, 75
 Side skirt, 73
 Support bar, 27
 Temperature, Light, 18
 Thermo-Sentry, 67
 Thermo-sentry, 18
 Vacuum fan seal, 76
Hopper door, Operate, 14
Hopper door lever, 14
Hopper door light, 19
Hopper lift lever, 15
Hopper support bar, 27
Hopper temperature light, 18
Horn button, 13
Hourmeter, 20
How the machine works, 30
Hydraulic fluid, 59–60
Hydraulic fluid reservoir, 59
Hydraulic hoses, 60
Hydraulics, 59–60
 Fluid, 59–60
 Fluid filter, 59
 Fluid level, 5, 59
 Hoses, 60
 Propelling motor, 60
 Reservoir, 59
 System specifications, 81

I

Ignition switch, 24

J

Jack points, 79–80

K

Knobs

 Main brush down pressure, 17
 Side brush down pressure, 25

L

Latches, 27

 Cab door, 27
 Engine cover, 27
 Engine side door, 27
 Grille doors, 27
 Hopper cover, 27
 Main brush doors, 27

Levers

 Hopper door, 14
 Hopper lift, 15
 Main brush and side brush, 13
 Main brush position, 16
 Parking brake, 12
 Side brush position, 25
 Steering column tilt, 23

Lights

 Charging system, 19
 Clogged filter, 19
 Engine oil pressure, 19
 Engine water temperature, 18
 Hazard light switch, 21
 Hopper door, 19
 Hopper temperature, 18
 Operating lights switch, 21

Lubrication, 58

 Engine, 58
 Front wheel bearings, 58
 Rear wheel support, 58

M

Machine components, 7
 Machine jacking, 79–80
 Machine leaks, 30, 41
 Main brush, 34–35, 67–70
 Adjust brush taper, 70–72
 Bristle length, 67
 Checking brush pattern, 69–71
 Door latch, 27
 Door seals, 74
 Door skirts, 73
 Down pressure, 17
 Lever, 13
 Maintenance, 67
 Position, 16
 Replacing, 68–69
 Main brush and side brush lever, 13
 Main brush down pressure knob, 17
 Main brush position lever, 16
 Maintenance, 56–77
 Intervals, 56–57
 Recommended, 6
 Maintenance chart, 56–57
 Motors, Propelling, 60

O

Operating lights switch, 21
 Operation, 5–53
 Operation on inclines, 44
 Operator Responsibility, 5
 Operator seat, 28
 Options, 45–52
 Blower wand, 51–52
 Cab door latch, 27
 Dome light switch, 29
 Hazard light switch, 21
 Heater switch, 29
 Heater valve, 54
 Heavy duty air filter, 62
 Pressurizer switch, 29
 Side brush dust control, 74
 Tie-downs, 53
 Turn signal switch, 17
 Vacuum wand, 45–50
 Windshield wiper switch, 29

P

Parking brake, 77
 Adjustment, 77
 Parking brake lever, 12
 Pedals
 Brake, 12
 Directional, 11
 Post-operation checklist, 41–42
 Pre-operation checklist, 30–31
 Pressurizer switch, 29
 Priming fuel system, 63
 Pushing machine, 78

R

Radiator, 61
 Coolant level, 6, 61
 Coolant type, 61
 Flushing system, 61
 Hoses, 61
 Rear wheel, 77

SPECIFICATIONS

S

Safety

- Disengaging hopper support bar, 43–44
- Engaging hopper support bar, 42–43
- Hopper support bar, 27
- Labels, 4
- Precautions, 3

Seals, 73–76

- Brush doors, 74
- Hopper, 75
- Hopper cover, 76
- Hopper door, 75
- Hopper dust, 76
- Hopper inspection door, 75
- Hopper vacuum fan seal, 76

Seat, 28

- Adjustment, 28
- Lift, 28

Service records, 41

Side brush, 35, 71–72

- Bristle length, 71
- Checking brush pattern, 71
- Down pressure, 25
- Lever, 13
- Position, 25
- Replacing, 72

Side brush down pressure knob, 25

Side brush dust control, 74

Side brush guard, 72

Side brush position lever, 25

Skirts, 41, 73–74

- Brush doors, 73
- Hopper Lip, 73
- Hopper side, 73
- Rear, 74
- Side brush dust control, 74

Specifications, 80–82

- Braking system, 81
- Hydraulic system, 81
- Machine capacities, 80
- Machine dimensions, 80
- Machine performance, 80
- Power type, 81
- Steering, 81
- Tires, 81

Starting the machine, 32–33

Static drag chain, 64

Steering, 31

- Specifications, 81

Steering column tilt lever, 23

Steering wheel, 23

Stop sweeping, 37

Stop the machine, 40–41

Storing machine, 79

Sweeping, 35–36

Sweeping and brush information, 34–35

Switches

- Dome light, 29
- Engine speed, 22
- Filter shaker, 23
- Hazard light, 21
- Heater, 29
- Ignition, 24
- Operating lights, 21
- Pressurizer, 29
- Turn signal, 17
- Vacuum fan, 21
- Windshield wiper, 29

T

Thermo-sentry, 67

Thermo-sentry, 18

Tie-downs, 53

Tires, 77–78

- Pressure, 77
- Rear wheel, 77
- Specifications, 81

Towing machine, 78

Towing valve, 78

Transporting machine, Tie-downs, 53

Travel speed, 80

Troubleshooting, 55

Turn signal switch, 17

V

Vacuum fan switch, 21

Vacuum wand, 45–50

W

Windshield wiper switch, 29