

FLOOR-EQUIPMENT-PARTS.COM



(Operator Manual)

242E



This manual is furnished with each new TENNANT Model 242E. It provides necessary operating and preventive maintenance instructions. Read this manual completely and understand the machine before operating or servicing it.

This manual covers all machine variations and standard accessories. The instruction portion of the manual consists of the Specification, Operation, Maintenance, and Appendix sections. The parts portion consists of the Low Dump Model Parts; Multi-Level Dump Model Parts; EE Parts; Options; Hydraulic Components; Electrical Components; and Cross Reference sections.

All right side and left side references to the machine are determined by facing the direction of forward travel. All hardware considered to be of a common nature or locally available has been omitted from the parts sections. Be aware that this machine may contain metric hardware. Make sure you use equivalent hardware when replacement becomes necessary.

This machine will provide excellent service. However, the best results will be obtained at minimum costs if:

- The machine is operated with reasonable care.
- The machine is maintained regularly – per the maintenance instructions provided.
- The machine is maintained with Tennant Company supplied or equivalent parts.

Parts and supplies may be ordered by phone or mail from any Tennant Company parts and service center, distributor, or from any of the Tennant Company subsidiaries. Before ordering parts or supplies, be sure to have your machine model number and serial number handy. Fill out the data block below for future reference. The telephone numbers, telex numbers, mailing addresses, and locations of those outlets are listed in the Customer Documents section of the manual.

MACHINE DATA	
<i>Please fill out at time of installation.</i>	
Machine Serial Number –	_____
Engine Serial Number –	_____
Sales Representative –	_____
Customer Number –	_____
Date of Installation –	_____
Manual Number –	MM243
Revision:	01
Published:	5–92

Trademark Registered in: Austria, Benelux, Denmark, England, France, Germany, Italy, Spain, Switzerland, United States, Argentina, Australia, Canada, Japan, Mexico, Sweden, by TENNANT COMPANY, Minneapolis, Minnesota, U.S.A.

Acknowledgements: Technical information and/or illustrations supplied by Sperry-Vickers Corporation; Eaton Corporation, Hydraulics Division and Lamb Electric.

Copyright 1989, 1992 Tennant Company, Printed in U.S.A.

SAFETY PRECAUTIONS

The following symbols are used throughout this manual as indicated in their descriptions:



WARNING: To warn of hazards or unsafe practices which could result in severe personal injury or death.

FOR SAFETY: To identify actions which must be followed for safe operation of equipment.

The following information signals potentially dangerous conditions to the operator or equipment. Read this manual carefully. Know when these conditions can exist. Locate all safety devices on the machine. Then, take necessary steps to train machine operating personnel. Report machine damage or faulty operation immediately. Do not use the machine if it is not in proper operating condition.

FOR SAFETY:

1. **Do Not Operate Machine:**
 - Unless Trained And Authorized.
 - Unless Operation Manual Is Read And Understood.
 - In Flammable Or Explosive Areas Unless Designed For Use In Those Areas.
 - In Areas With Possible Falling Objects Unless Equipped With Overhead Guard.
2. **Before Starting Machine:**
 - Make Sure All Safety Devices Are In Place And Operate Properly.
 - Check Brakes And Steering For Proper Operation.
3. **When Starting Machine:**
 - Keep Foot On Brake And Directional Pedal In Neutral.
4. **When Using Machine:**
 - Use Brakes To Stop Machine.
 - Go Slow On Grades And Slippery Surfaces.
 - Use Care When Backing Machine.
 - Move Machine With Care When Hopper Is Raised.
 - Make Sure Adequate Clearance Is Available Before Raising Hopper.
 - Do Not Carry Riders On Machine.
 - Always Follow Safety And Traffic Rules.

5. **Before Leaving Or Servicing Machine:**
 - Stop On Level Surface.
 - Set Parking Brake.
 - Turn Off Machine And Remove Key.
6. **When Servicing Machine:**
 - Avoid Moving Parts. Do Not Wear Loose Jackets, Shirts, Or Sleeves When Working On Machine.
 - Block Machine Tires Before Jacking Machine Up.
 - Jack Machine Up At Designated Locations Only. Block Machine Up With Jack Stands.
 - Use Hoist Or Jack Of Adequate Capacity To Lift Machine.
 - Wear Eye And Ear Protection When Using Pressurized Air Or Water.
 - Disconnect Battery Connections Before Working On Machine.
 - Avoid Contact With Battery Acid.
 - Use Cardboard To Locate Leaking Hydraulic Fluid Under Pressure.
 - Use TENNANT Supplied Or Equivalent Replacement Parts.



WARNING: Batteries Emit Hydrogen Gas. Explosion Or Fire Can Result. Keep Sparks And Open Flame Away. Keep Covers Open When Charging.



WARNING: Lift Arm Pinch Point. Stay Clear Of Hopper Lift Arms.



WARNING: Raised Hopper May Fall. Engage Hopper Support Bar.



WARNING: Brush Throws Debris. Stop Motor Before Lifting Hopper.



WARNING: Flammable Materials Can Cause An Explosion Or Fire. Do Not Use Flammable Materials In Tank(s).



WARNING: Flammable Materials Or Reactive Metals Can Cause Explosion Or Fire. Do Not Pick Up.

GENERAL INFORMATION

The following safety labels are mounted on the machine in the locations indicated. If these, or any, labels become damaged or illegible, install a new label in its place.

HOPPER SUPPORT BAR LABEL -- LOCATED ON HOPPER SUPPORT BAR, BOTH HOPPER LIFT ARMS AND CENTER PANEL, LOW DUMP MODEL ONLY

CAUTION!

WHILE WORKING ON HOPPER IN RAISED POSITION USE SAFETY SUPPORT ARM TO ENGAGE SAFETY SUPPORT ARM

TO ENGAGE SAFETY SUPPORT ARM

1. LIFT HOPPER TO EXTREME UP POSITION
2. RAISE SAFETY SUPPORT ARM
3. LOWER HOPPER AGAINST STOP
4. SHUT ENGINE OFF.

TO DISENGAGE SAFETY SUPPORT ARM

1. LIFT HOPPER TO EXTREME UP POSITION.
2. LOWER SAFETY SUPPORT ARM.
3. LOWER HOPPER.



CHARGING LABEL -- LOCATED ON THE UNDERSIDE OF THE BATTERY COVER.

CAUTION

BEFORE AND DURING CHARGING

1. CHARGE ONLY IN A WELL VENTILATED AREA.
2. AREA ABOVE BATTERIES MUST BE CLEAR OF ALL OBSTRUCTIONS.
3. ADD ONLY ENOUGH DISTILLED WATER TO COVER PLATES. (DO NOT FILL COMPLETELY)
4. DO NOT CHARGE FOR MORE THAN 24 HOURS.

AFTER CHARGING

1. UNPLUG CHARGER.
2. FILL BATTERIES TO PROPER LEVEL WITH DISTILLED WATER.

NO SMOKING OR OPEN FLAME IN AREA

HOPPER IS RAISED LABEL -- LOCATED ON THE LINTEL, MULTI-LEVEL DUMP MODEL ONLY

CAUTION

MOVE MACHINE WITH CARE WHEN THE HOPPER IS RAISED

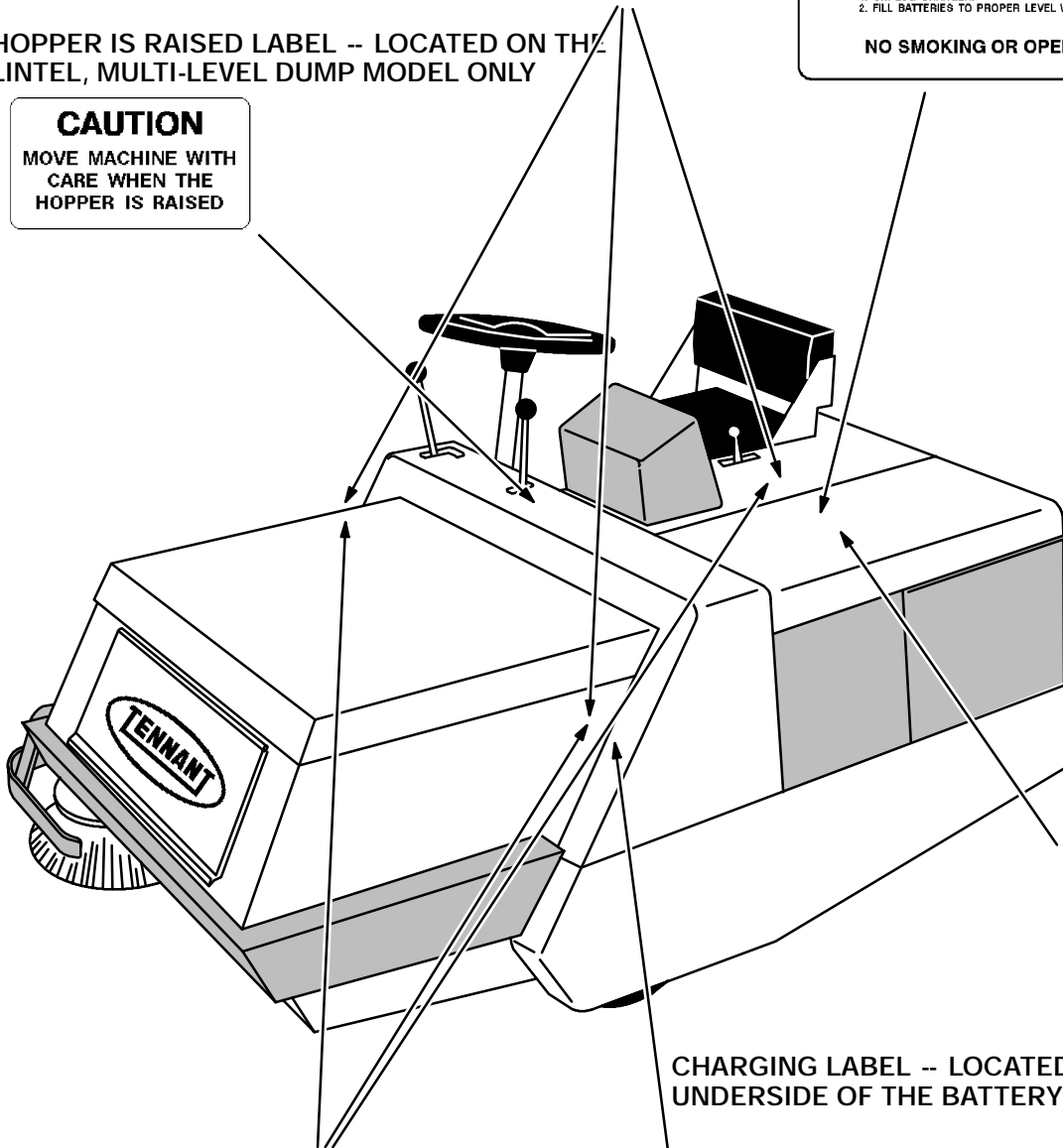

CAUTION

Explosive Gas Is Given Off By Batteries During Charge.

1. Keep Battery Compartment Cover Open.
2. No Smoking. Flame Or Sparks in Area.
3. Charge Only in Well Ventilated Area.

CHARGING LABEL -- LOCATED ON THE UNDERSIDE OF THE BATTERY COVER.

05542



WARNING

Engage Safety Support Bar Per Instructions Before Working Under Hopper



INSTRUCTIONS

To Engage Safety Support Bar:

1. Lift Hopper To Extreme Up Position.
2. Raise Safety Support Bar.
4. Lower Hopper Onto support Bar.
5. Shut Off Engine.

HOPPER SUPPORT BAR LABEL -- LOCATED ON THE HOPPER SUPPORT, BOTH HOPPER LIFT ARMS AND CENTER PANEL, MULTI-LEVEL DUMP MODEL ONLY



CAUTION

Stay Clear of Hopper Lift Arms.

LIFT ARM CLEARANCE LABEL -- LOCATED ON BOTH HOPPER LIFT ARMS, MULTI-LEVEL DUMP MODEL ONLY

CONTENTS

	Page		Page
GENERAL INFORMATION	i	MACHINE OPERATION	2-10
SAFETY PRECAUTIONS	i	NORMAL SWEEPING OPERATION	2-10
SPECIFICATIONS	1-1	PRE-START CHECKLIST	2-10
MACHINE SPECIFICATIONS	1-3	TO START MACHINE	2-10
POWER TYPE	1-3	TO SWEEP	2-10
POWER TRAIN	1-3	TO DUMP HOPPER	2-11
STEERING	1-3	POST OPERATION CHECKLIST –	
HYDRAULIC SYSTEM	1-3	MOTOR OPERATING	2-11
BRAKING SYSTEM	1-4	TO STOP MACHINE	2-11
SUSPENSION SYSTEM	1-4	POST OPERATION CHECKLIST –	
SYSTEM FLUID CAPACITIES	1-4	MOTOR STOPPED	2-12
GENERAL MACHINE DIMENSIONS –		TO ENGAGE HOPPER SUPPORT BAR .	2-12
CAPACITIES	1-4	TO DISENGAGE HOPPER SUPPORT	
MACHINE WEIGHTS	1-4	BAR	2-13
GENERAL MACHINE PERFORMANCE .	1-4	OPERATION ON GRADES	2-13
MACHINE DIMENSIONS	1-5	NORMAL SCRUBBING OPERATION ...	2-13
OPERATION	2-1	PRE-START CHECKLIST	2-13
PREPARATION FOR OPERATION	2-3	TO START MACHINE	2-14
AFTER UNLOADING AND BEFORE		TO SCRUB	2-14
OPERATING THE MACHINE:	2-3	TO DRAIN RECOVERY TANK AND EMPTY	
OPERATION OF CONTROLS	2-4	DEBRIS HOPPER	2-15
MACHINE COMPONENTS	2-4	POST OPERATION CHECKLIST –	
CONTROLS AND INSTRUMENTS	2-5	MOTOR OPERATING	2-16
BRAKE PEDAL	2-6	TO STOP MACHINE	2-16
DIRECTIONAL PEDAL	2-6	DOUBLE SCRUBBING OPERATION ...	2-16
PARKING BRAKE	2-6	MACHINE TROUBLESHOOTING –	
MAIN BRUSH DOWN PRESSURE KNOB	2-6	SWEEPING	2-17
HOPPER LIFT AND SIDE BRUSH LEVER	2-6	MACHINE TROUBLESHOOTING –	
FILTER SHAKER SWITCH	2-7	SCRUBBING	2-19
VACUUM CONTROL HANDLE	2-7	TRANSPORTING MACHINE	2-20
OPERATING LIGHTS SWITCH	2-7	PUSHING OR TOWING MACHINE	2-20
HOUR METER	2-7	MACHINE JACKING	2-20
VOLTMETER	2-7	TO JACK UP MACHINE	2-20
HAZARD LIGHT SWITCH	2-7	MACHINE STORAGE	2-21
SCRUB BRUSH SWITCH	2-7	STORING MACHINE	2-21
SCRUB VACUUM SWITCH	2-7	OPTIONS	2-22
KEY-OPERATED ON-OFF SWITCH	2-7	HOPPER DOLLY	2-22
START SWITCH	2-7	TO REMOVE HOPPER WITH DOLLY	2-22
MAIN BRUSH POSITION LEVER	2-7	TO INSTALL HOPPER WITH DOLLY .	2-22
HOPPER DUMP LEVER	2-8	SCRUB ATTACHMENT	2-23
STEERING WHEEL	2-8	TO MOUNT SCRUB ATTACHMENT .	2-23
SIDE BRUSH POSITION LEVER	2-8	TO REMOVE SCRUB ATTACHMENT	2-25
HOPPER SUPPORT BAR	2-8		
SCRUB BRUSH POSITION LEVER	2-8		
SOLUTION FLOW KNOBS	2-9		
CIRCUIT BREAKER AND FUSES	2-9		

GENERAL INFORMATION

	Page		Page
MAINTENANCE	3-1	BELTS AND CHAINS	3-23
RECOMMENDED FIRST 50-HOUR		PUMP BELT	3-23
MACHINE INSPECTION	3-3	TO REPLACE PUMP BELT	3-23
MAINTENANCE CHART	3-4	COUNTERSHAFT BELT	3-23
LUBRICATION	3-6	MAIN BRUSH BELT	3-24
REAR WHEEL SUPPORT	3-6	VACUUM FAN BELT	3-24
STEERING GEAR	3-6	SCRUB ATTACHMENT VACUUM	
FRONT WHEEL BEARINGS	3-6	FAN BELT	3-24
HOPPER LIFT ARM PIVOTS	3-7	STATIC DRAG CHAIN	3-24
HOPPER DOOR LATCHES	3-7	DEBRIS HOPPER	3-25
COUNTERSHAFT BELT IDLER	3-8	HOPPER DUST FILTER	3-25
SCRUB ATTACHMENT SCRUB BRUSH		TO REMOVE HOPPER DUST FILTER	3-25
GEAR	3-8	TO INSTALL HOPPER DUST FILTER	3-26
SCRUB ATTACHMENT LEG CASTERS	3-8	HOPPER FUSIBLE LINK	3-26
SCRUB ATTACHMENT DEBRIS		TO REPLACE HOPPER FUSIBLE	
HOPPER	3-8	LINK	3-26
HYDRAULICS	3-9	DEBRIS HOPPER	3-27
HYDRAULIC FLUID	3-9	TO ADJUST LOW DUMP MODEL	
HYDRAULIC FLUID RESERVOIR	3-9	HOPPER	3-27
TO DRAIN THE HYDRAULIC FLUID		TO ADJUST MULTI-LEVEL DUMP	
RESERVOIR	3-10	MODEL HOPPER	3-27
TO FILL THE HYDRAULIC FLUID		BRUSHES	3-31
RESERVOIR	3-10	MAIN BRUSH	3-31
HYDRAULIC FLUID RESERVOIR		TO REPLACE MAIN BRUSH	3-31
BREATHER	3-10	TO CHECK AND ADJUST MAIN	
HYDRAULIC FLUID FILTER	3-10	BRUSH PATTERN	3-31
TO REPLACE HYDRAULIC FLUID		SIDE BRUSH	3-32
FILTER ELEMENT	3-10	TO REPLACE SIDE BRUSH	3-33
HYDRAULIC PUMPS	3-11	SKIRTS AND SEALS	3-34
TO START AND BREAK-IN		HOPPER LIP SKIRTS	3-34
HYDRAULIC PUMP	3-11	TO REPLACE HOPPER LIP SKIRTS	3-34
DIRECTIONAL PEDAL	3-12	BRUSH DOOR AND SIDE SKIRTS	3-34
TO ADJUST DIRECTIONAL PEDAL		TO REPLACE AND ADJUST BRUSH	
NEUTRAL POSITION	3-12	DOOR SKIRT	3-34
SPEED LIMITER	3-13	TO REPLACE AND ADJUST SIDE	
HYDRAULIC FLUID LEAKS	3-13	SKIRT	3-35
HYDRAULIC COMPONENTS		REAR SKIRT	3-35
TROUBLESHOOTING	3-14	TO REPLACE AND ADJUST THE	
HYDRAULIC SCHEMATIC, LOW DUMP		REAR SKIRT	3-35
(For machines below serial number		MAIN BRUSH DOOR SEALS	3-35
005106)	3-15	HOPPER SEALS	3-36
HYDRAULIC SCHEMATIC, LOW DUMP (For		HOPPER INSPECTION DOOR SEAL	3-36
machines serial number 005106		HOPPER DOOR SEALS	3-36
and above)	3-16	HOPPER COVER SEAL	3-36
HYDRAULIC SCHEMATIC, MULTI-LEVEL		HOPPER VACUUM FAN SEAL	3-37
DUMP (For machines below serial		BRAKES AND TIRES	3-38
number 005106)	3-17	SERVICE BRAKES	3-38
HYDRAULIC SCHEMATIC, MULTI-LEVEL		TO ADJUST BRAKE LINKAGE	3-38
DUMP (For machines serial number		TIRES	3-38
005106 and above)	3-18		
ELECTRICAL SYSTEM	3-19		
BATTERIES	3-19		
BATTERY CHARGING	3-20		
TO CHARGE BATTERIES	3-20		
ELECTRIC MOTORS	3-21		
ELECTRIC SCHEMATIC	3-22		

	Page		Page
OPTIONS	3-39	Fig. 15 – Hydraulic System	5-27
SCRUB ATTACHMENT	3-39	Fig. 16 – Main Control Valve Group	5-28
SOLUTION TANKS	3-39	Fig. 17 – Hydraulic Reservoir Assembly ...	5-29
SOLUTION DISTRIBUTION SYSTEM ...	3-39	Fig. 18 – Directional Control Group	5-30
SCRUB BRUSHES	3-39	Fig. 19 – Directional Control Group	5-32
TO REPLACE SCRUB BRUSH	3-40	Fig. 20 – Rear Drive Wheel Motor Group ..	5-34
TO CHECK AND ADJUST SCRUB		Fig. 21 – Hopper Lift Cylinder and Side	
BRUSH PATTERN	3-41	Brush Motor Group	5-35
RECOVERY TANK	3-42	Fig. 22 – Rear Drive Wheel and Support	
TO DRAIN THE RECOVERY TANK ..	3-42	Group	5-36
TO CLEAN THE RECOVERY TANK ..	3-43	Fig. 23 – Battery Wire Harness Group	5-37
DEBRIS HOPPER	3-43	Fig. 24 – Hourmeter Group	5-38
SIDE SQUEEGEE	3-44	Fig. 25 – Voltmeter Group	5-38
TO REPLACE SIDE SQUEEGEE		Fig. 26 – Overhead Guard Group	5-39
BLADE	3-44	Fig. 27 – Bumper Group	5-40
REAR SQUEEGEE	3-45		
TO REPLACE OR ROTATE REAR		MULTI-LEVEL DUMP MODEL PARTS	6-1
BLADE	3-45	ORDERING REPAIR PARTS	6-3
TO CHECK AND ADJUST REAR		Fig. 1 – Main Frame Group, Multi-Level	
SQUEEGEE	3-47	Dump	6-4
APPENDIX	4-1	Fig. 2 – Hopper Lift Arms Group,	
HARDWARE INFORMATION	4-3	Multi-Level Dump	6-6
STANDARD BOLT TORQUE CHART ...	4-3	Fig. 3 – Hopper Group, Multi-Level Dump	6-8
METRIC BOLT TORQUE CHART	4-3	Fig. 4 – Filter Carrier Group, Multi-Level	
BOLT IDENTIFICATION	4-3	Dump	6-10
THREAD SEALANT AND LOCKING		Fig. 5 – Hopper Door Assembly,	
COMPOUNDS	4-3	Multi-Level Dump	6-11
HYDRAULIC FITTING INFORMATION	4-4	Fig. 6 – Vacuum Fan Bracket Group,	
HYDRAULIC TAPERED PIPE FITTING (NPT)		Multi-Level Dump	6-12
TORQUE CHART	4-4	Fig. 7 – Front Wheels and Brake Group,	
HYDRAULIC TAPERED SEAT FITTING (JIC)		Multi-Level Dump	6-13
TORQUE CHART	4-4	Fig. 8 – Main Brush Drive Group,	
HYDRAULIC O-RING FITTING TORQUE		Multi-Level Dump	6-14
CHART	4-4	Fig. 9 – Side Brush Arm Assembly,	
LOW DUMP MODEL PARTS	5-1	Multi-Level Dump	6-15
ORDERING REPAIR PARTS	5-3	Fig. 10 – Hydraulic System, Multi-Level	
Fig. 1 – Recommended General		Dump	6-16
Maintenance Items	5-4	Fig. 11 – Hydraulic System, Multi-Level	
Fig. 2 – Replacement Brushes	5-5	Dump	6-17
Fig. 3 – Main Frame Group	5-6	Fig. 12 – Dump Cylinder and Valve Group,	
Fig. 4 – Seat and Battery Panel Group ...	5-8	Multi-Level Dump	6-18
Fig. 5 – Instrument and Component		Fig. 13 – Main Control Valve and Hopper Lift	
Panel Group	5-10	Cylinder Group, Multi-Level	
Fig. 6 – Hopper Group	5-12	Dump	6-19
Fig. 7 – Hopper Cover and Fire Door		Fig. 14 – Side Brush Motor Group,	
Group	5-14	Multi-Level Dump	6-20
Fig. 8 – Filter Shaker Group	5-16	Fig. 15 – Directional Control Group,	
Fig. 9 – Vacuum Fan Group	5-18	Multi-Level Dump	6-21
Fig. 10 – Front Wheels and Brakes Group	5-20	Fig. 16 – Bumper Group, Multi-Level Dump	6-22
Fig. 11 – Main Brush Drive Group	5-22	Fig. 17 – Overhead Guard Group,	
Fig. 12 – Side Brush Lift Group	5-24	Multi-Level Dump	6-23
Fig. 13 – Steering Wheel Group	5-25		
Fig. 14 – Hydraulic System	5-26	EE MODEL PARTS	7-1
		ORDERING REPAIR PARTS	7-3
		Fig. 1 – Instrument and Component Panel	
		Group, EE	7-4

GENERAL INFORMATION

	Page
OPTIONS	8-1
ORDERING REPAIR PARTS	8-3
Fig. 1 – Revolving Light Kit	8-4
Fig. 2 – Revolving Light Kit, EE	8-5
Fig. 3 – Operating Light Kit, Lintel Mount, Low Dump	8-6
Fig. 4 – Operating Light Kit, Lintel Mount, Multi-Level Dump	8-7
Fig. 5 – Operating Light Kit, Lintel Mount, EE	8-8
Fig. 6 – Overhead Guard Kit	8-9
Fig. 7 – Bumper Kit, Low Dump (Prepped for Scrubbing)	8-10
Fig. 8 – Bumper Kit, Low Dump, EE (Not Prepped for Scrubbing) ..	8-11
Fig. 9 – Bumper Kit, Low Dump, EE (Prepped for Scrubbing)	8-12
Fig. 10 – Bumper Kit, Multi-Level Dump, EE	8-13
Fig. 11 – Prep For Scrub Kit	8-14
Fig. 12 – Detergent Distribution Group ...	8-15
Fig. 13 – Scrub Tank Frame Group	8-16
Fig. 14 – Solution and Recovery Tanks Group	8-18
Fig. 15 – Main Scrub Brush Drive Group ..	8-20
Fig. 16 – Rear Squeegee Group	8-22
Fig. 17 – Side Squeegee Group	8-24
Fig. 18 – Hour Meter Kit, EE	8-25
Fig. 19 – Charger Kit, 1 PH	8-25
Fig. 20 – Charger Kit, 3 PH	8-25
Fig. 21 – Battery Group, EE	8-26
Fig. 22 – Battery Group, Wet	8-26
Fig. 23 – Battery Group, Dry (Export only)	8-26
Fig. 24 – Motor Enclosure Band Kit	8-26
Fig. 25 – Motor Enclosure Band Kit	8-26
Fig. 26 – Motor Enclosure Band Kit	8-26
Fig. 27 – Squeegee Blade Kit	8-26
Fig. 28 – Hopper Dolly Assembly, Low Dump	8-27
Fig. 29 – Scrub Vacuum Fan Drive Group, EE	8-28
Fig. 30 – Vacuum Fan Assembly, EE	8-30
Fig. 31 – Solution and Recovery Tanks Group, EE	8-32
Fig. 32 – Main Scrub Brush Drive Group, EE	8-34
Fig. 33 – Scrub Tank Frame Group, EE ...	8-36
Fig. 34 – Detergent Distribution Group, EE	8-38
Fig. 35 – Maximum Path Side Brush Group	8-39

	Page
HYDRAULIC COMPONENTS	9-1
ORDERING REPAIR PARTS	9-3
Fig. 1 – Hydraulic Pump, 47862	9-4
Fig. 2 – Hydraulic Pump Breakdown, 61440	9-6
Fig. 3 – Accessories Pump Breakdown, 50126	9-8
Fig. 4 – Hydraulic Motor Breakdown, 48663	9-9
Fig. 5 – Hydraulic Motor Breakdown, 27791	9-10
Fig. 6 – Hydraulic Motor Breakdown, 27794	9-11
Fig. 7 – Hydraulic Valve Breakdown, 32391	9-12
Fig. 8 – Hydraulic Valve Breakdown, 32752	9-12
ELECTRICAL COMPONENTS	10-1
ORDERING REPAIR PARTS	10-3
Fig. 1 – Electric Motor Breakdown, 46690A	10-4
Fig. 2 – Electric Motor Breakdown, 31891	10-6
Fig. 3 – Electric Motor Breakdown, 50089	10-6
Fig. 4 – Electric Motor Breakdown, 25985	10-7
Fig. 5 – Electric Motor Breakdown, 46691B	10-7
CROSS REFERENCE	11-1
PART NUMBER TO PAGE NUMBER CROSS REFERENCE LIST	11-3

SECTION 1**CONTENTS**

	Page
MACHINE SPECIFICATIONS	1-3
POWER TYPE	1-3
POWER TRAIN	1-3
STEERING	1-3
HYDRAULIC SYSTEM	1-3
BRAKING SYSTEM	1-4
SUSPENSION SYSTEM	1-4
SYSTEM FLUID CAPACITIES	1-4
GENERAL MACHINE DIMENSIONS – CAPACITIES	1-4
MACHINE WEIGHTS	1-4
GENERAL MACHINE PERFORMANCE	1-4
MACHINE DIMENSIONS	1-5

MACHINE SPECIFICATIONS

POWER TYPE

Electric propelling motor – nominal voltage
36 VDC, 7 hp (5.22 kW) @ 2200 rpm
Electric scrub brush motor – nominal voltage
36 VDC, 1 hp (0.75 kW) @ 2000 rpm
Electric scrub vacuum fan drive motor – nominal
voltage 36 VDC, 1.2 hp (0.9 kW) @
2550 rpm

Batteries (2) – 18 V, 600 A/h @ 6 hour rate
Battery charger (accessory) –
36 VDC 120 A, 208–240–480 VAC,
60 Hz, 1 PH
36 VDC 120 A, 208–240–480 VAC,
60 Hz, 3 PH

POWER TRAIN

Propelling – hydraulic motor driven
Main brush – belt driven
Side brush – hydraulic motor driven
Vacuum fan – belt driven
Hydraulic pump – belt driven

STEERING

Type – rear wheel controlled, automotive cam and
lever

HYDRAULIC SYSTEM

Function – operate propelling, hopper lift and
dump, side brush drive
Control valve, hopper lift, side brush drive – open
center type, single spool
Control valve, hopper dump, multi-level dump
model – open center type, single spool
Pump propelling (for machines below serial number
005106) – variable displacement piston type,
2.01 cu in (35 cc) maximum displacement per
revolution, 8 gpm (30.3 L/min) @ 2400 rpm
Pump propelling (for machines serial number
005106 and above) – variable displacement
piston type, 2.48 cu in (41 cc) maximum
displacement per revolution, 22.7 gpm
(86 L/min) @ 2400 rpm

Propelling system relief pressure (for machines
below serial number 005106) – 3000 psi
(20685 kPa)

Propelling system relief pressure (for machines
serial number 005106 and above) – 2750 psi
(17238 kPa)

Pump accessories (for machines below serial
number 005106) – vane type, 2 gpm (7.6
L/min) @ 1200 rpm

Pump accessories (for machines serial number
005106 and above) – gear type, 4.8 gpm
(18 L/min) @ 2500 rpm

Side brush and hopper lift cylinder system relief
pressure – 2000 psi (13790 kPa)

Motor, propelling – internal gear type, 19 cu in
(310 cc) displacement per revolution, 4500 psi
(31,030 kPa) maximum rated pressure

Motor, side brush (for machines below serial
number 005106) – internal gear type, 4.5 cu in
(75 cc) displacement per revolution, 2000 psi
(13790 kPa) maximum rated pressure

Motor, side brush (for machines serial number
005106 and above) – internal gear type,
5.9 cu in (97 cc) displacement per revolution,
2500 psi (17238 kPa) maximum rated pressure

Cylinder, hopper lift, low dump model – single
action type, 2.50 in (65 mm) bore x 6.00 in
(155 mm) stroke, 1.13 in (285 mm) diameter
rod, 2500 psi (17238 kPa) maximum rated
pressure

Cylinder, hopper lift, multi-level dump model –
single action type, 3.50 in (90 mm) bore x
8.00 in (20 mm) stroke, 1.25 in (30 mm)
diameter rod, 2500 psi (17238 kPa) maximum
rated pressure

Cylinder, hopper dump, multi-level dump model (2)
– single action type, 2.00 in (50 mm) bore x
5.37 in (15 mm) stroke, 1.00 in (25 mm)
diameter rod, 2500 psi (17238 kPa) maximum
rated pressure

SPECIFICATIONS

BRAKING SYSTEM

Service brakes – mechanical drum brakes (2) – 1 per front wheel, linkage actuated
Parking brakes – utilizes service brakes, linkage actuated

SUSPENSION SYSTEM

Front (2) – 16 in (410 mm) x 3.5 in (90 mm) solid tire
Rear (1) – 16.25 in (415 mm) x 6 in (155 mm) solid tire

SYSTEM FLUID CAPACITIES

Hydraulic system – reservoir 5 gal (18.9 L)
Hydraulic system – total system 6.5 gal (24.6 L)

GENERAL MACHINE DIMENSIONS – CAPACITIES

Length, low dump model – 86.50 in (2200 mm)
Length, multi-level dump model – 93 in (2360 mm)

Width, low dump model – 56.75 in (1440 mm)
Width, multi-level dump model – 57.75 in (1470 mm)

Height – 50.75 in (1290 mm)
Height with overhead guard – 81.4 in (2070 mm)
Height with cab – 81.4 in (2070 mm)
Height with cab and hazard light – 90.70 in (2300 mm)
Track – 46.5 in (1180 mm)

Wheel base – 40 in (1015 mm)

Main brush diameter – 14 in (355 mm)
Main brush length – 42 in (1070 mm)

Side brush diameter – 21 in (535 mm)

Sweeping path width – 42 in (1070 mm)
Sweeping path width with side brush – 53 in (1345 mm)

Hopper capacity – 14 ft³ (0.4 m³) 1000 lb (455 kg)

Dust filter area – 110 ft² (10.2 m²)

MACHINE WEIGHTS

GVWR, low dump model – 4750 lb (2155 kg)
GVWR, multi-level dump model – 5250 lb (2381 kg)

GENERAL MACHINE PERFORMANCE

Maximum forward speed – 5 mph (8 km/h)
Maximum reverse speed – 3 mph (5 km/h)

Minimum aisle turn width, low dump model, left – 102 in (2590 mm)

Minimum aisle turn width, low dump model, right – 158 in (4015 mm)

Minimum aisle turn width, multi-level dump model, left – 106 in (2690 mm)

Minimum aisle turn width, multi-level dump model, right – 158 in (4015 mm)

Maximum rated climb/descent angle – 6° with full hopper, 7° with an empty hopper

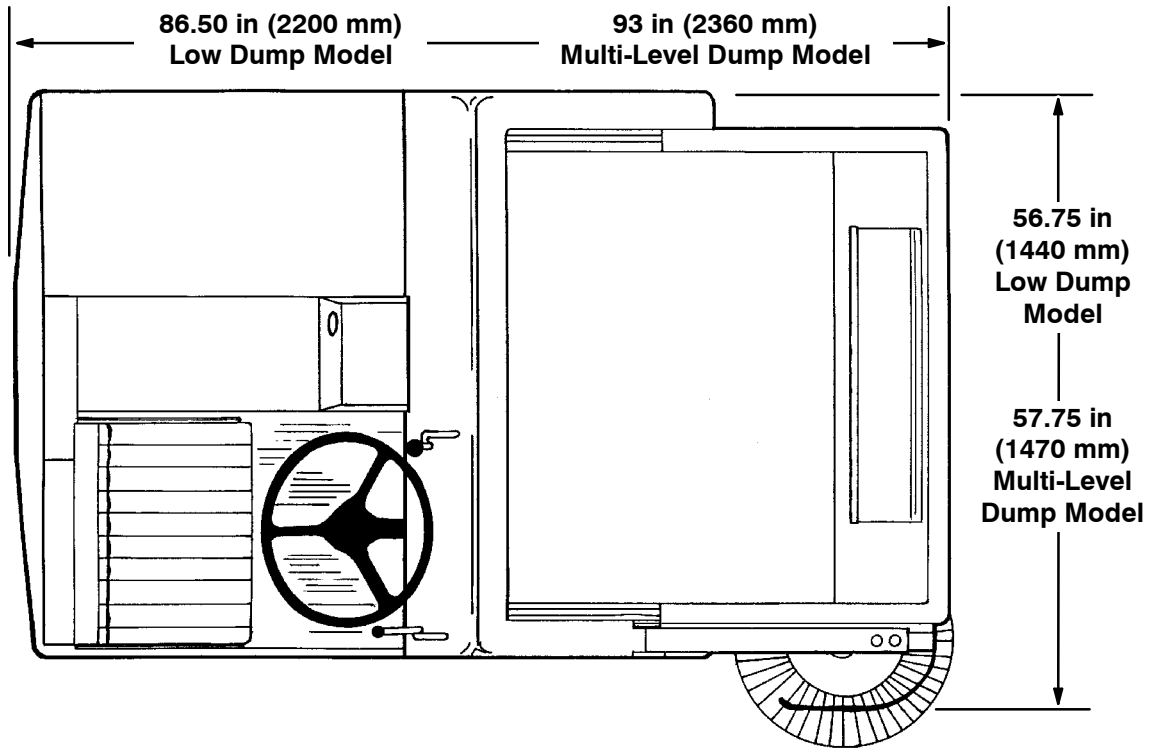

TOP VIEW

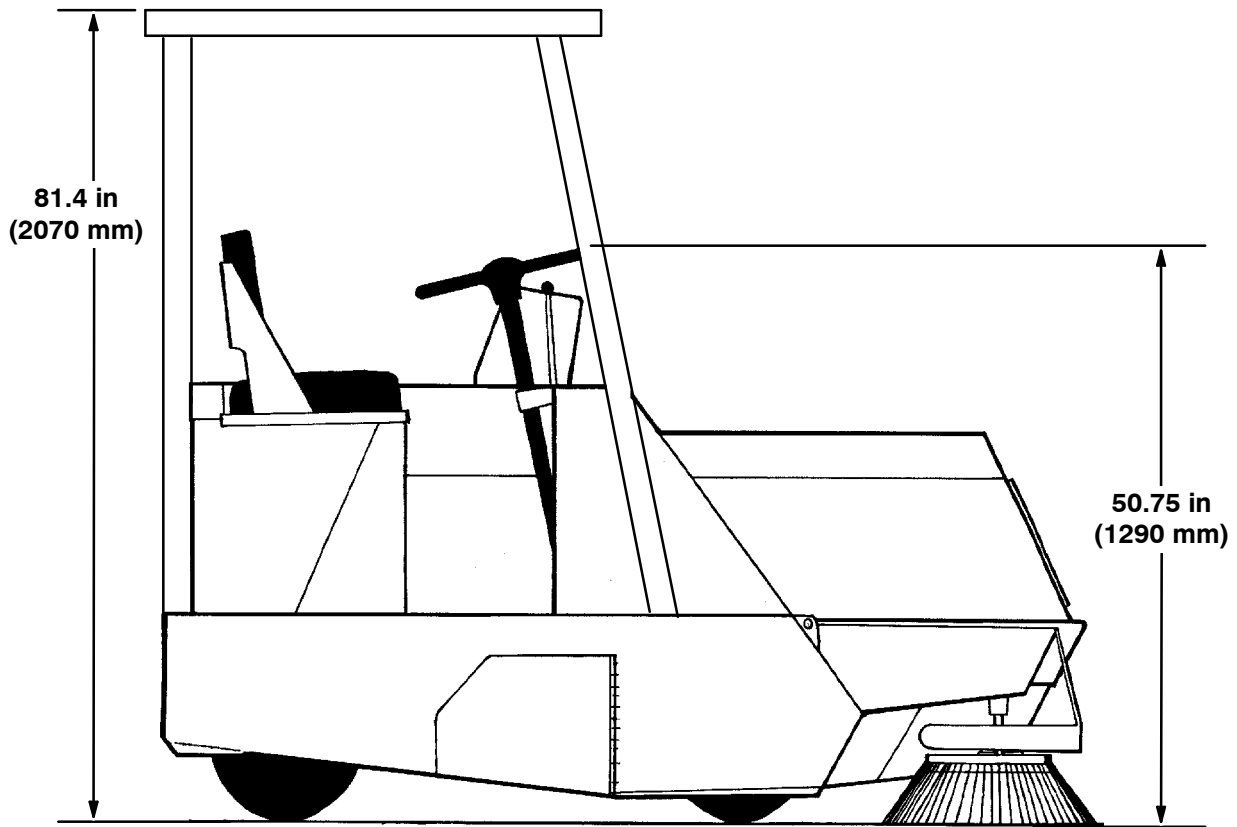

SIDE VIEW

MACHINE DIMENSIONS

05183
05539

SECTION 2

CONTENTS

	Page		Page
PREPARATION FOR OPERATION	2-3	DOUBLE SCRUBBING OPERATION	2-16
AFTER UNLOADING AND BEFORE OPERATING		MACHINE TROUBLESHOOTING –	
THE MACHINE:	2-3	SWEEPING	2-17
OPERATION OF CONTROLS	2-4	MACHINE TROUBLESHOOTING –	
MACHINE COMPONENTS	2-4	SCRUBBING	2-19
CONTROLS AND INSTRUMENTS	2-5	TRANSPORTING MACHINE	2-20
BRAKE PEDAL	2-6	PUSHING OR TOWING MACHINE	2-20
DIRECTIONAL PEDAL	2-6	MACHINE JACKING	2-20
PARKING BRAKE	2-6	TO JACK UP MACHINE	2-20
MAIN BRUSH DOWN PRESSURE KNOB ..	2-6	MACHINE STORAGE	2-21
HOPPER LIFT AND SIDE BRUSH LEVER ..	2-6	STORING MACHINE	2-21
FILTER SHAKER SWITCH	2-7	OPTIONS	2-22
VACUUM CONTROL HANDLE	2-7	HOPPER DOLLY	2-22
OPERATING LIGHTS SWITCH	2-7	TO REMOVE HOPPER WITH DOLLY ...	2-22
HOUR METER	2-7	TO INSTALL HOPPER WITH DOLLY ...	2-22
VOLTMETER	2-7	SCRUB ATTACHMENT	2-23
HAZARD LIGHT SWITCH	2-7	TO MOUNT SCRUB ATTACHMENT ...	2-23
SCRUB BRUSH SWITCH	2-7	TO REMOVE SCRUB ATTACHMENT ...	2-25
SCRUB VACUUM SWITCH	2-7		
KEY-OPERATED ON-OFF SWITCH	2-7		
START SWITCH	2-7		
MAIN BRUSH POSITION LEVER	2-7		
HOPPER DUMP LEVER	2-8		
STEERING WHEEL	2-8		
SIDE BRUSH POSITION LEVER	2-8		
HOPPER SUPPORT BAR	2-8		
SCRUB BRUSH POSITION LEVER	2-8		
SOLUTION FLOW KNOBS	2-9		
CIRCUIT BREAKER AND FUSES	2-9		
MACHINE OPERATION	2-10		
NORMAL SWEEPING OPERATION	2-10		
PRE-START CHECKLIST	2-10		
TO START MACHINE	2-10		
TO SWEEP	2-10		
TO DUMP HOPPER	2-11		
POST OPERATION CHECKLIST –			
MOTOR OPERATING	2-11		
TO STOP MACHINE	2-11		
POST OPERATION CHECKLIST –			
MOTOR STOPPED	2-12		
TO ENGAGE HOPPER SUPPORT BAR ...	2-12		
TO DISENGAGE HOPPER SUPPORT BAR	2-13		
OPERATION ON GRADES	2-13		
NORMAL SCRUBBING OPERATION	2-13		
PRE-START CHECKLIST	2-13		
TO START MACHINE	2-14		
TO SCRUB	2-14		
TO DRAIN RECOVERY TANK AND EMPTY			
DEBRIS HOPPER	2-15		
POST OPERATION CHECKLIST –			
MOTOR OPERATING	2-16		
TO STOP MACHINE	2-16		

PREPARATION FOR OPERATION

AFTER UNLOADING AND BEFORE OPERATING THE MACHINE:

1. Check the machine for shipping damage.
2. Read this manual carefully before operating or servicing the machine.

FOR SAFETY: Do Not Operate The Machine, Unless Operation Manual Is Read And Understood.

3. Install the batteries. Because of clearance limitations between the battery and the machine, when installing the batteries; use the end holes on the left-hand battery, and the side holes on the right-hand battery.
4. Check the hydraulic fluid level in the hydraulic fluid reservoir, using the dipstick provided. TENNANT hydraulic fluid is recommended. If TENNANT hydraulic fluid is not available, use only new, approved hydraulic fluid. See *HYDRAULICS* in the *MAINTENANCE* section.
5. Check to be sure the fusible link on the filter box fire door has not been broken during shipment. If replacement is necessary, see *TO REPLACE HOPPER FUSIBLE LINK* in the *MAINTENANCE* section.
6. Check the batteries electrolyte level as described in *BATTERIES* in the *MAINTENANCE* section.

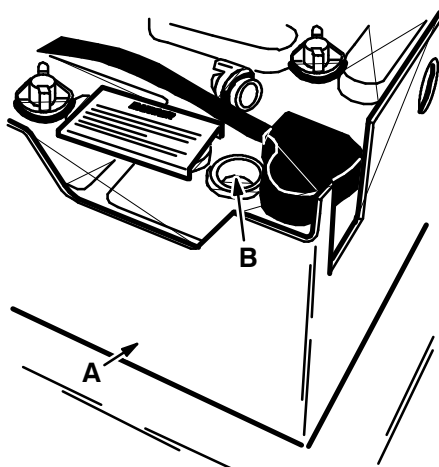

03700

CHECKING BATTERY ELECTROLYTE LEVEL

- A. Battery**
- B. Filling Hole**

FOR SAFETY: When Servicing Machine, Avoid Contact With Battery Acid.

7. Charge the batteries as directed in *TO CHARGE BATTERIES* in the *MAINTENANCE* section.

! WARNING: Batteries Emit Hydrogen Gas. Explosion Or Fire Can Result. Keep Sparks And Open Flame Away. Keep Covers Open When Charging.

8. Connect the battery connectors to the machine connectors.

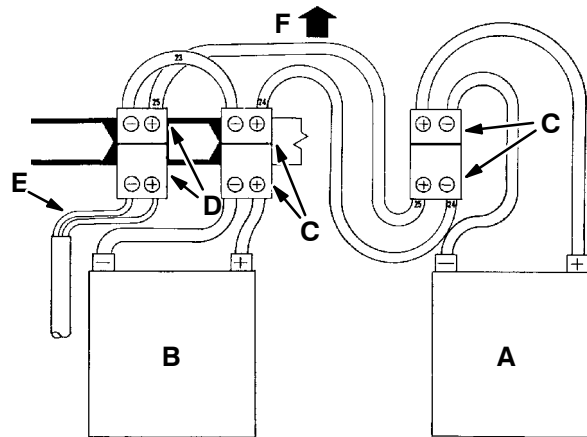

05181

BATTERY CONNECTORS

- A. Right Hand Battery**
- B. Left Hand Battery**
- C. Orange Connector**
- D. Grey Connector**
- E. Motor Cable**
- F. Front Of Machine**

OPERATION OF CONTROLS

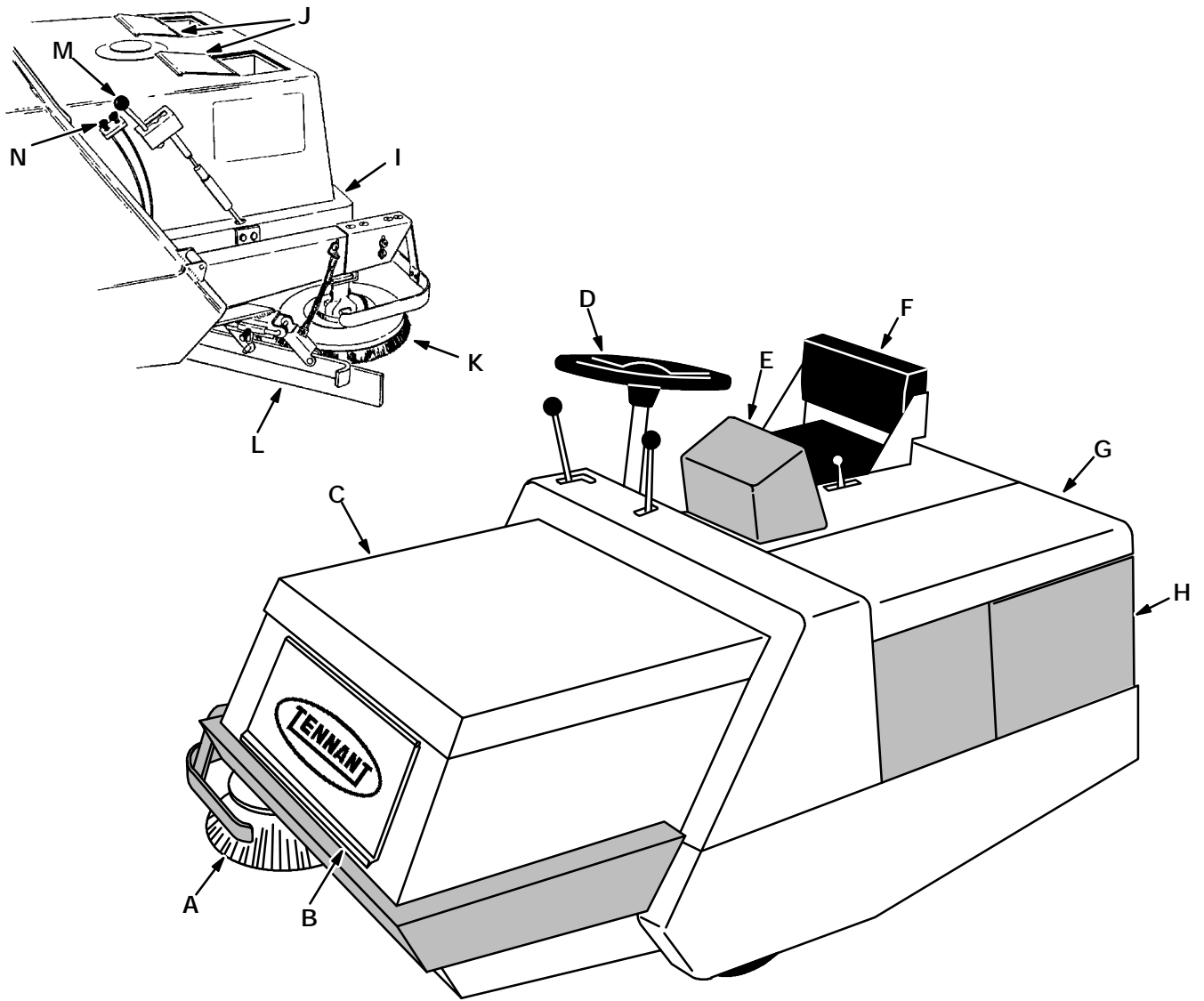

MACHINE COMPONENTS

- | | |
|-----------------------------|-------------------------------|
| A. Side Brush | H. Battery |
| B. Hopper Front Access Door | I. Scrub Attachment |
| C. Hopper Cover | J. Solution Tank Cover |
| D. Steering Wheel | K. Side Scrub Brush |
| E. Instrument Panel | L. Side Squeegee |
| F. Operator Seat | M. Scrub Brush Position Lever |
| G. Battery Cover | N. Solution Flow Knobs |

05540
05542

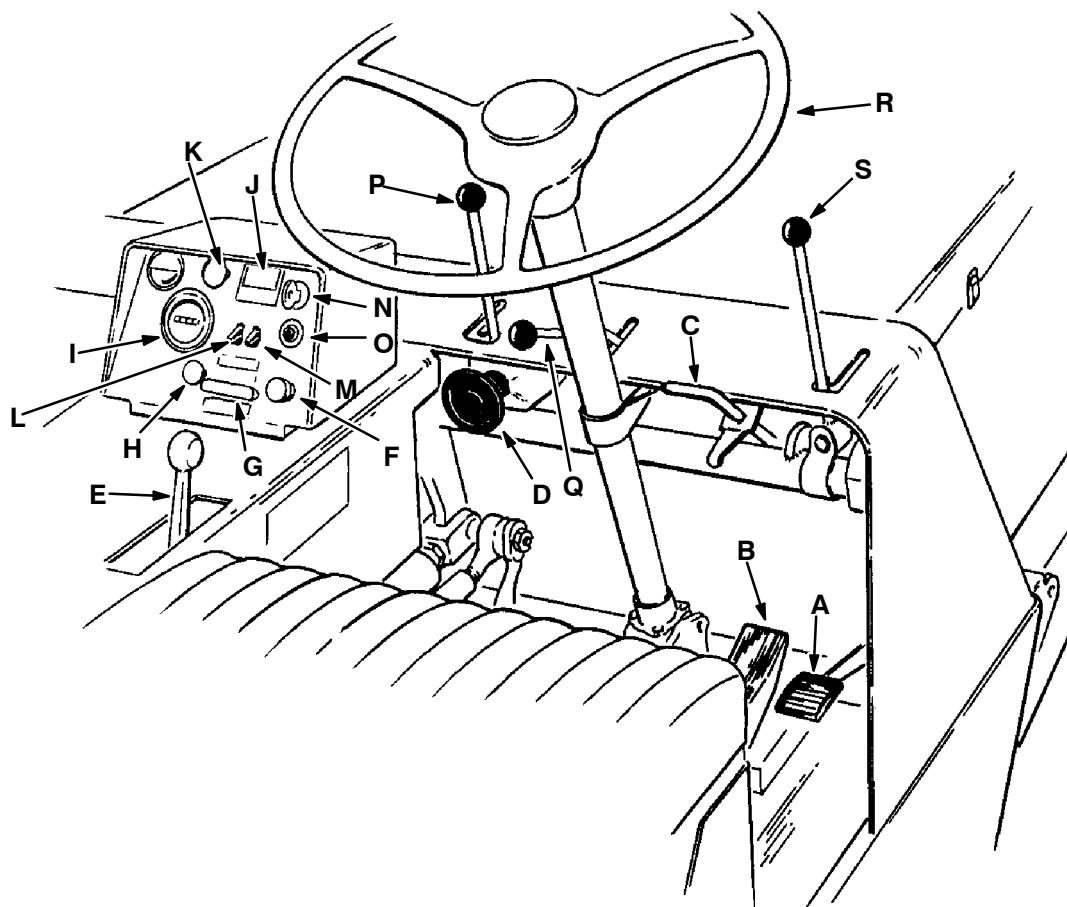

CONTROLS AND INSTRUMENTS

05182

- | | |
|-------------------------------------|-------------------------------|
| A. Brake Pedal | K. Hazard Light Switch |
| B. Directional Pedal | L. Scrub Brush Switch |
| C. Parking Brake | M. Scrub Vacuum Switch |
| D. Main Brush Down Pressure Knob | N. Key-Operated On-Off Switch |
| E. Hopper Lift and Side Brush Lever | O. Start Switch |
| F. Filter Shaker Switch | P. Main Brush Position Lever |
| G. Vacuum Control Handle | Q. Hopper Dump Lever |
| H. Operating Lights Switch | R. Steering Wheel |
| I. Hour Meter | S. Side Brush Position Lever |
| J. Voltmeter | |

OPERATION

BRAKE PEDAL

The brake pedal operates the mechanical drum brakes on the two front wheels.

To stop the machine, return the directional pedal to neutral; then apply pressure to the brake pedal.

DIRECTIONAL PEDAL

The directional pedal controls the propelling drive. It is used to select the direction of travel and the propelling speed of the machine.

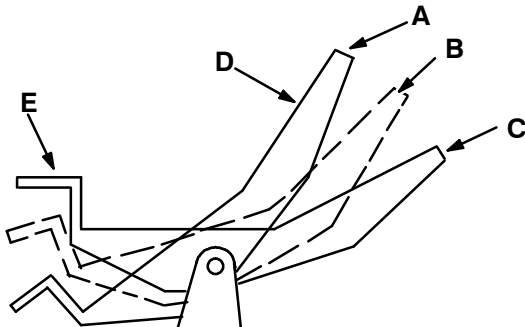

DIRECTIONAL PEDAL

- A. "Reverse" Position
- B. "Neutral" Position
- C. "Forward" Position
- D. "Toe" Portion
- E. "Heel" Portion

00116

To travel forward, press the "toe" portion of the pedal; to travel backward, press the "heel" portion of the pedal. The propelling speed of the machine is regulated by varying the pressure on the pedal.

PARKING BRAKE

The parking brake lever operates the front wheel brakes. To set the parking brake, pull the handle up. To release the parking brake, pull the quick-release tab. Always park on a level surface, stop the motor, and set the parking brake before leaving the machine unattended and before working on the machine.

FOR SAFETY: Before Leaving Or Servicing Machine; Stop On Level Surface, Set Parking Brake, Turn Off Machine And Remove Key.

MAIN BRUSH DOWN PRESSURE KNOB

The main brush down pressure knob adjusts the main brush contact with the floor. By turning the pressure knob, the main brush contact with the floor will increase or decrease.

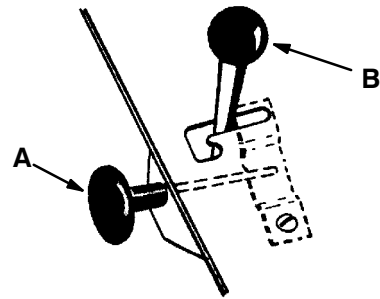

07312

MAIN BRUSH DOWN PRESSURE KNOB

- A. Down Pressure Knob
- B. Main Brush Position Lever

HOPPER LIFT AND SIDE BRUSH LEVER

The hopper lift and side brush lever controls the hopper lift cylinders and the side brush drive motor.

To lift the hopper, push the lever forward into the "RAISE HOPPER" position until the desired height is reached. Be sure adequate vertical clearance is available before raising the hopper.

To hold the hopper up, push the lever into the "HOLD HOPPER" position. Do not rely on the hydraulic system to keep the hopper up if work is to be done on the machine. Always engage the hopper support bar.

WARNING: Raised Hopper May Fall. Engage Hopper Support Bar.

To lower the hopper, push the lever into the "OFF LOWER HOPPER" position.

To start side brush rotation, push the lever into the "SIDE BRUSH ON" position.

To stop side brush rotation, pull the lever back into the "OFF LOWER HOPPER" position.

FILTER SHAKER SWITCH

The filter shaker switch activates the filter shaker. Press in and hold the filter shaker switch for 10 to 15 seconds at a time to clean the filters.

NOTE: The vacuum must be shut off before using the filter shaker switch.

Low Dump Model Machines: Pull out the vacuum control handle.

Multi-Level Dump Model Machines: Turn the machine off, then back on. Press the filter shaker switch. When the filter shaker has stopped, press the start switch to start the motor and continue sweeping.

VACUUM CONTROL HANDLE

The vacuum control handle controls the vacuum system on the low dump model. To shut the vacuum off, pull out the handle and turn clockwise to hold in place. To open the vacuum, turn the handle counter-clockwise to release it, and push the handle in.

OPERATING LIGHTS SWITCH

The operating lights switch is present on a machine with the operating lights accessory. The switch turns on and off the operating lights.

HOURLY METER

The hour meter records the number of hours the machine has operated. This information is useful in determining when to service the machine.

VOLTMETER

The voltmeter indicates the battery state of charge. When the gauge needle is in the red zone, the batteries should be recharged.

HAZARD LIGHT SWITCH

The hazard light switch is present on machines with the hazard light accessory. The switch turns on and off the hazard light.

SCRUB BRUSH SWITCH

The scrub brush switch is present on a machine equipped with a scrub attachment. The scrub brush switch turns on and off the scrub brush.

SCRUB VACUUM SWITCH

The scrub vacuum switch is present on a machine equipped with a scrub attachment. The scrub vacuum switch turns on and off the scrub vacuum system.

KEY-OPERATED ON-OFF SWITCH

The key-operated on-off switch controls all the machine power. To allow the machine to operate, turn the key clockwise. To turn the machine off, turn the key counter-clockwise.

START SWITCH

The start switch starts the motor of the machine. The key-operated on-off switch must be turned on and the operator must be seated in the operator seat before the start switch will start the motor. Press the start switch and release it when the motor starts.

MAIN BRUSH POSITION LEVER

The main brush position lever controls the position of the main brush.

To lower and start the main brush into the restricted down position, pull the lever back and all the way to the left, and lower it into the "RESTRICTED DOWN" position.

To raise the main brush, pull the lever back and to the right into the "RAISED POSITION".

NOTE: The brush should never be used in the "FREE FLOAT" position.

When the hopper is raised, the main brush will stop rotating on the low dump model machines.

NOTE: Always place the main brush lever in the "RAISED POSITION" when the main brush is not in operation. This will prevent the main brush from getting a flat spot.

OPERATION

HOPPER DUMP LEVER

The hopper dump lever is present on multi-level dump model machines. The lever is used to dump the hopper.

To dump the hopper, raise the hopper to the desired height with the hopper lift and side brush lever, then push the hopper dump lever forward into the “ROLL OUT” position.

FOR SAFETY: When Using Machine, Make Sure Adequate Clearance Is Available Before Raising Hopper.

To return the hopper to its operating position, pull the hopper dump lever back into the “ROLL IN” position. Lower the hopper with the hopper lift and side brush lever.

STEERING WHEEL

The steering wheel controls the rear wheel through an arm and tie rod. The machine is very responsive to steering wheel movements. Use care until you become more experienced in guiding the machine.

A horn button is located in the center of the steering wheel.

SIDE BRUSH POSITION LEVER

The side brush position lever controls the position of the side brush.

To lower the side brush, pull the lever back, and to the right into the long slot.

To raise the side brush, pull the lever back and to the left into the short slot.

NOTE: Always raise the side brush when it is not in operation.

HOPPER SUPPORT BAR

The hopper support bar is located on the operator's side of the hopper. It holds the hopper in a “RAISE HOPPER” position to allow work to be done under the hopper. Do not rely on the machine hydraulic system to keep the hopper raised.



**WARNING: Raised Hopper May Fall.
Engage Hopper Support Bar.**

SCRUB BRUSH POSITION LEVER

The scrub brush position lever is located on the right side of the scrub attachment. The lever controls the position of the scrub brush.

The scrub brush may be positioned in either a raised, normal, or restricted down position. The raised position is used when the scrub attachment is not in use. The normal position is for general scrubbing. The restricted down position is used to remove compacted soilage.

To raise the scrub brush, pull the lever all the way back and to the right.

To lower the scrub brush, push the lever forward and into the middle notch. This is the normal position. Push the lever all the way forward and into the last notch for the restricted down position.

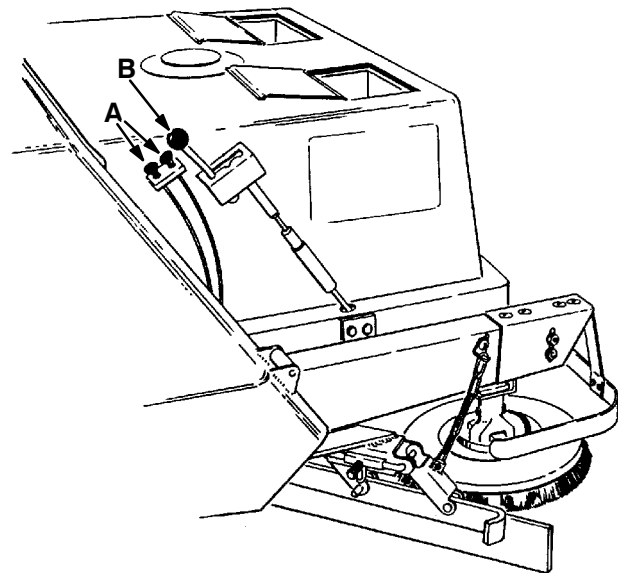

SCRUB ATTACHMENT

05540

- A. Solution Flow Knob**
- B. Scrub Brush Position Lever**

SOLUTION FLOW KNOBS

The solution flow knobs controls the solution flow rate to the floor. There is one knob for each of the two separate solution tanks, right and left. The knobs can be used one at a time, or both at the same time.

To increase solution flow, pull the knob out. To decrease solution flow, push the knob in. Pushing the knob all of the way in will stop solution flow.

CIRCUIT BREAKER AND FUSES

The circuit breaker is a resetable circuit protection devices designed to stop the flow of current in the event of a circuit overload. Once tripped, the circuit breaker must be allowed to cool and then will automatically reset. If the overload which caused the circuit breaker to trip is still present in the circuit, the circuit breaker will continue to stop current flow until the overload is corrected.

Fuses are a one-time circuit protection device designed to stop the flow of current in the event of a circuit overload. Never substitute higher value fuses than those specified in this manual.

The circuit breaker is located inside the instrument panel enclosure along with the fuse panel.

The following chart shows the various circuit breakers and fuses, and the electrical components they protect.

PROTECTIVE DEVICE	RATING	CIRCUIT PROTECTED
CB	150 A	Machine Power
FU (2)	15 A	Starter
FU	15 A	Hour Meter
FU	5 A	Filter Shaker
FU	15 A	Horn
FU	15 A	Hazard Light
FU	15 A	Operating Lights
FU	60 A	Scrub Attachment Brush Motor
FU	30 A	Scrub Attachment Vacuum Fan Motor
FU	60 A	EE Scrub Attachment Vacuum Fan Motor

MACHINE OPERATION

NORMAL SWEEPING OPERATION

A normal sweeping operation consists of seven typical operations: pre-start checklist, starting machine, sweeping, dumping hopper, post operation checklist – motor operating, stopping machine, and post operation checklist – motor stopped.

PRE-START CHECKLIST lists things to check before starting the machine.

TO START MACHINE lists the steps required to start the machine.

TO SWEEP lists things to keep in mind before and during the sweeping operation.

TO DUMP HOPPER lists the steps required to dump the hopper.

POST OPERATION CHECKLIST – MOTOR OPERATING lists things to check before stopping the machine motor.

TO STOP MACHINE lists the steps required to stop the machine.

POST OPERATION CHECKLIST – MOTOR STOPPED lists things to check after stopping the machine motor.

PRE-START CHECKLIST

Check under machine for leak spots.

Check the brushes and brush skirts for damage, wear and adjustment.

Check brakes and controls for proper operation.

Check service records to determine service requirements.

TO START MACHINE

NOTE: Before starting machine, perform the pre-start checks.

1. The machine operator must be in the operator's seat with the directional pedal in the "neutral" position and with a foot on the brake pedal or with the parking brake engaged.

FOR SAFETY: Before Starting Machine, Make Sure All Safety Devices Are In Place And Operate Properly.

2. Turn the key-operated on-off switch clockwise.
3. Press and hold the start switch until the motor starts. Release the start switch.
4. Release the parking brake.
5. Drive the machine to the area to be swept.

TO SWEEP

Plan the sweeping in advance. Try to arrange long runs with minimum stopping and starting. Sweep debris from very narrow aisles into main aisles ahead of time. Do an entire floor or section at one time.

Pick up oversize debris before sweeping. Flatten or remove bulky cartons from aisles before sweeping. Pick up pieces of wire, twine, string, etc., which could become entangled in brush or brush plugs. Overlap brush paths.

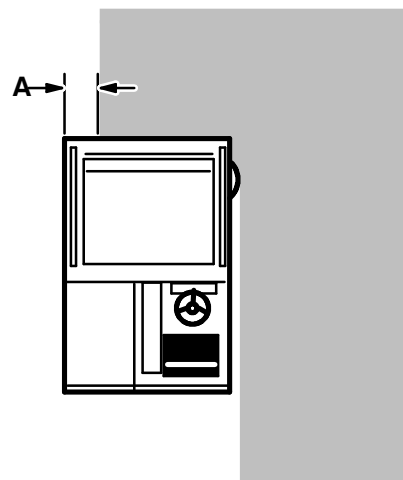

OVERLAPPING PATHS

A. Overlapping Width

04622

Avoid turning the steering wheel too sharply when the machine is in motion. The machine is very responsive to the movement of the steering wheel. Avoid sudden turns, except in emergencies.

Sweep as straight a path as possible. Avoid bumping into posts or scraping the sides of the sweeper.

ATTENTION: The magnetic field produced by the motors in this machine may cause damage to computer memory devices if the machine is used in the same room while computers are being operated.

1. Pull the hopper lift and side brush lever into the "SIDE BRUSH ON" position.
2. Move the main brush position lever into the "RESTRICTED DOWN" position, and lower the side brush with the side brush position lever.
3. Low dump model machines: Open the vacuum with the vacuum control knob.
4. Sweep as required.

TO DUMP HOPPER

1. Pull the main brush position lever back into the "RAISED POSITION".
2. Raise the side brush with the side brush position lever.
3. Push the hopper lift and side brush lever into the "OFF LOWER HOPPER" position to stop the side brush rotation.
4. Low Dump Model Machines: Shut off the vacuum with the vacuum control knob.

Multi-Level Dump Model Machines: Raise the hopper at least a quarter of the way up to break the vacuum seal.

5. Press and hold the filter shaker switch for 10 to 15 seconds.
6. Slowly drive the machine up to the dump site or dumpster.

7. Low Dump Model Machines: Push the hopper lift and side brush lever forward into the "RAISE HOPPER" position to dump the hopper. Push the lever into the "HOLD HOPPER" position to keep the hopper in the dumped position.

Multi-Level Dump Model Machines: Push the hopper lift and side brush lever forward into the "RAISE HOPPER" position to lift the hopper to the desired height. Be aware: The minimum ceiling clearance needed to multi-level dump the hopper is 112 in (2845 mm).

FOR SAFETY: When Using Machine, Make Sure Adequate Clearance Is Available Before Raising Hopper.

Multi-Level Dump Model Machines: Push the lever forward into the "HOLD HOPPER" position to keep the hopper at the desired height; then push the hopper dump lever into the "ROLL OUT" position to dump the hopper.

NOTE: Lowering the hopper into the dumpster may help to control flying dust.

Multi-Level Dump Model Machines: Pull the hopper dump lever back into the "ROLL IN" position to return the hopper to its normal angle, then release the lever.

8. Pull the hopper lift and side brush lever into the "OFF LOWER HOPPER" position to return the hopper to its operating position.
9. Slowly back the machine away from the dump site or dumpster.

POST OPERATION CHECKLIST – MOTOR OPERATING

Check brush patterns for width and evenness.

TO STOP MACHINE

1. Return the directional pedal to the "neutral" position. Apply the brake.
2. Pull the main brush position lever into the "RAISED POSITION" and raise the side brush with the side brush position lever.
3. Place the hopper lift and side brush lever in the "OFF LOWER HOPPER" position.
4. Turn the operating lamps off if used.

OPERATION

5. Set the machine parking brake.

FOR SAFETY: Before Leaving Or Servicing Machine; Stop On Level Surface, Set Parking Brake, Turn Off Machine And Remove Key.

6. Turn off the machine and remove the key.

POST OPERATION CHECKLIST – MOTOR STOPPED

Check the skirts for damage, wear, and adjustment.

Check for wire or string tangled on the brushes.

Check under the machine for leak spots.

TO ENGAGE HOPPER SUPPORT BAR

1. Set the machine parking brake and start the machine.

FOR SAFETY: Before Leaving Or Servicing Machine; Stop On Level Surface, Set Parking Brake, Turn Off Machine And Remove Key.

2. Fully raise the hopper.
3. Lift and position the hopper support bar under the hopper lift arm pin on low dump models, or hopper lift arm cam on multi-level dump models.

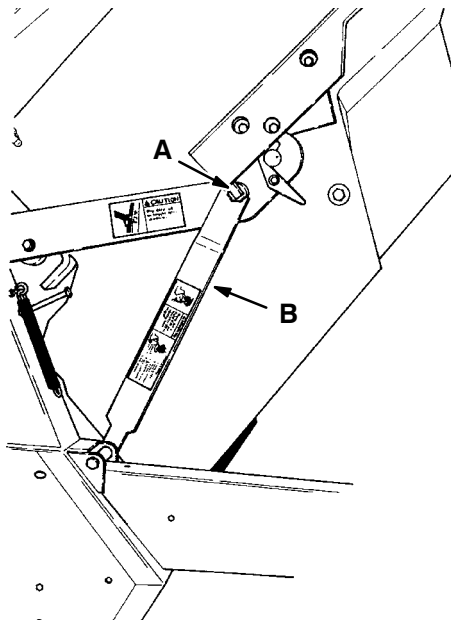

**ENGAGED HOPPER SUPPORT BAR –
LOW DUMP MODEL**

- A. Lift Arm Pin
- B. Support Bar

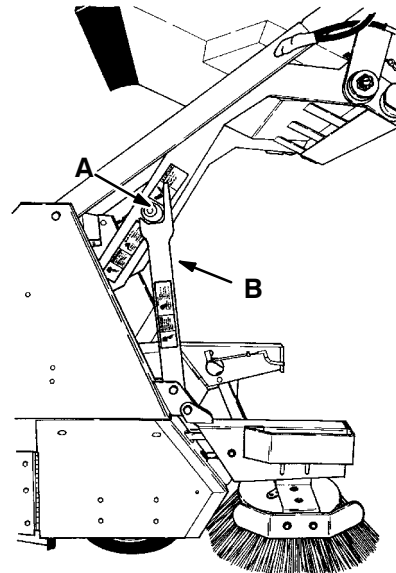

**ENGAGED HOPPER SUPPORT BAR –
MULTI-LEVEL DUMP MODEL**

02467

- A. Lift Arm Cam
- B. Support Bar

4. Slowly lower the hopper so the lift arm pin or cam rests on the support bar.
5. Turn the machine off.
6. Check the support bar to make sure it is securely engaged.

TO DISENGAGE HOPPER SUPPORT BAR

1. Start the machine.
2. Fully raise the hopper.
3. Place the support bar in its storage position.

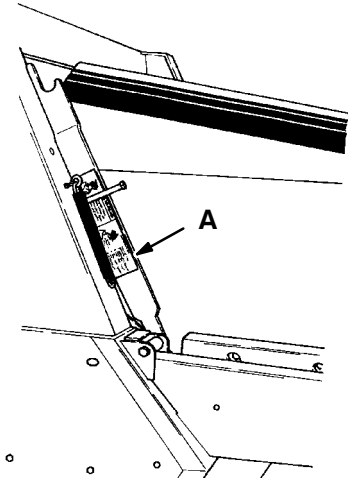

02489

**DISENGAGED HOPPER SUPPORT BAR --
LOW DUMP MODEL**

A. Support Bar

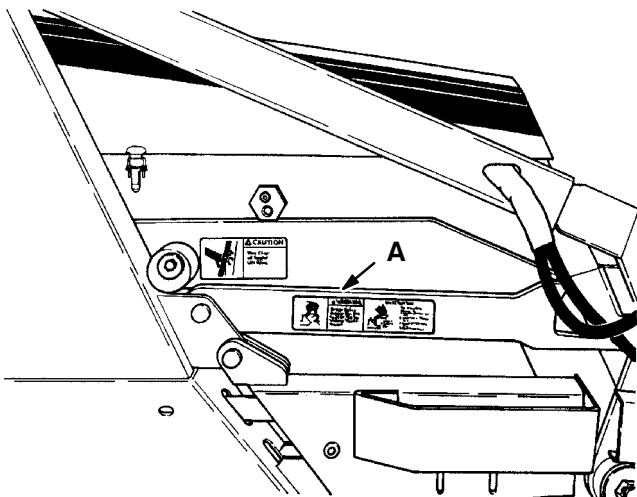

02450

**DISENGAGED HOPPER SUPPORT BAR --
MULTI-LEVEL DUMP MODEL**

A. Support Bar

4. Lower the hopper.
5. Turn the machine off.

OPERATION ON GRADES

Drive the machine slowly on grades. Use the service brakes to control machine speed.

FOR SAFETY: When Using Machine, Go Slow On Grades And Slippery Surfaces.

The maximum rate ramp climb and descent angle is 7° with an empty hopper, and 6° with a full hopper.

NORMAL SCRUBBING OPERATION

A normal scrubbing operation consists of seven typical operations: pre-start checklist, starting machine, scrubbing, draining recovery tank and emptying hopper, post operation checklist – motor operating, stopping machine, and post operation checklist – motor stopped.

PRE-START CHECKLIST lists things to check before starting the machine.

TO START MACHINE lists the steps required to start the machine.

TO SCRUB lists things to keep in mind before and during the scrubbing operation.

TO DRAIN RECOVERY TANK AND EMPTY HOPPER lists the steps required to empty the debris hopper and the recovery tank.

POST OPERATION CHECKLIST – MOTOR OPERATING lists things to check before stopping the machine motor.

TO STOP MACHINE lists the steps required to stop the machine.

POST OPERATION CHECKLIST – MOTOR STOPPED lists things to check after stopping the machine motor.

PRE-START CHECKLIST

Check under machine for leak spots.

Check the brushes and brush skirts for damage, wear and adjustment.

Check brakes and controls for proper operation.

Check service records to determine service requirements.

OPERATION

TO START MACHINE

NOTE: Before starting machine, perform the pre-start checks.

1. The machine operator must be in the operator's seat with the directional pedal in the "neutral" position and with a foot on the brake pedal or with the parking brake engaged.

FOR SAFETY: Before Starting Machine Make Sure All Safety Devices Are In Place And Operate Properly.

2. Turn the key-operated on-off switch clockwise.
3. Press and hold the start switch until the motor starts. Release the start switch.
4. Release the parking brake.
5. Drive the machine to the area to be scrubbed.

TO SCRUB

Plan the scrubbing in advance. Try to arrange long runs with minimum stopping and starting. Do an entire floor or section at one time.

Pick up oversize debris before scrubbing. Remove bulky debris from aisles before scrubbing. Pick up pieces of wire, twine, string, etc., which could become entangled in brush or brush plugs.

Allow a few inches overlap of brush paths.

Do not turn steering wheel too sharply when the machine is in motion. It is very responsive to the movement of the steering wheel. Avoid sudden turns, except in emergencies.

Try to scrub as straight a path as possible. Avoid bumping into posts or scraping the sides of the machine.

Floor conditions, amount of soilage, type of soilage, brush action, and squeegee action all play an important role in determining the type and concentration of detergent to be used. For specific recommendations, consult the local Tennant Company Representative.



WARNING: Flammable Materials Can Cause An Explosion Or Fire. Do Not Use Flammable Materials In Tank(s).

The recovery tank should be drained after the solution tanks are empty or whenever the ball float rises and stops water vacuum. The recovery tank may fill before the solution tanks empty if standing water is picked up in addition to the solution put down by the machine.



WARNING: Flammable Materials Or Reactive Metals Can Cause Explosion Or Fire. Do Not Pick Up.

For best scrubbing results, reduce speed to one-half maximum machine speed. Shut off solution flow to floor 5 ft (1525 mm) before making turns. Adjust solution flow to floor with solution flow knobs to match floor conditions.

Always raise the rear squeegee before backing machine.

1. Turn off the machine and set the parking brake before filling solution tanks.

FOR SAFETY: Before Leaving Or Servicing Machine; Stop On Level Surface, Set Parking Brake, Turn Off Machine And Remove Key.

2. Make sure the solution flow knobs are pushed all the way in to shut off the solution flow to the floor.

3. Open the solution tanks covers. There are two solution tanks. One or both tanks may be used for detergent solution or rinse water. The water flow can be almost doubled by using both tanks at the same time, but this will require more frequent filling.

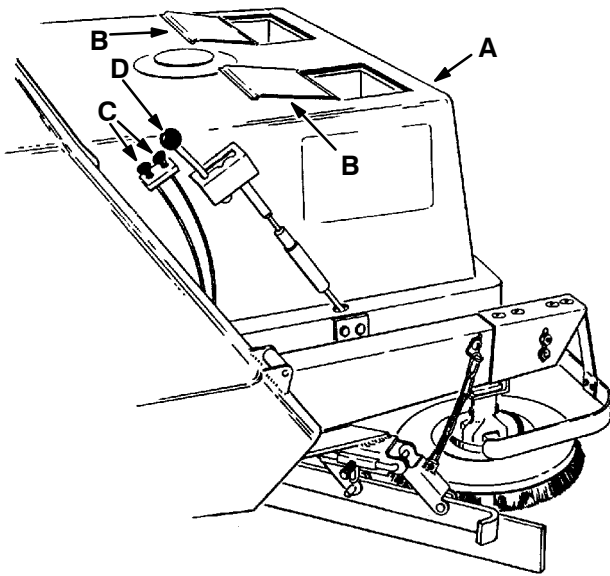

SCRUB ATTACHMENT

05540

- A. Solution Tank**
- B. Solution Tank Cover**
- C. Solution Flow Knob**
- D. Scrub Brush Position Lever**

4. Pour the required amount of detergent into the tanks. Fill the tanks with water. The water must not be hotter than 130° F (54° C) or solution tank and system damage may occur.
5. Start and drive the machine to the area to be scrubbed.
6. Turn on the scrub brush with the scrub brush switch.
7. Push the hopper lift and side brush lever into the "SIDE BRUSH ON" position.
8. Turn on the scrub attachment vacuum system with the scrub vacuum switch.
9. Move the main brush position lever into the "RESTRICTED DOWN" position.
10. Lower the scrub brush into the normal position.

11. Lower the side brush with the side brush position lever. The side squeegee will lower with the side brush. Make sure the side squeegee is not in the locked up position.
12. Pull out the solution flow knobs to be used to start the solution flow to the floor.
13. Lower the rear squeegee placing the lever in the notch for proper down pressure.
14. Scrub as required. Adjust the solution flow to match floor conditions. When the solution tanks empty or the recovery tank ball float stops vacuum, return to the solution dump/filling site. Drain the recovery tank, empty the hopper, and refill the solution tank.

NOTE: The horn will sound if the scrub brush motor overheats. The cause of the overload should be found before continued operation of the scrub attachment. Refer to ELECTRICAL TESTS in the MAINTENANCE section.

TO DRAIN RECOVERY TANK AND EMPTY DEBRIS HOPPER

1. Push in the solution flow knobs to stop the solution flow.
2. Pull the main brush position lever into the "RAISED POSITION" and raise the side brush with the side brush position lever.
3. Place the hopper lift and side brush lever in the "OFF LOWER HOPPER" position.
4. Turn off the scrub attachment vacuum system with the scrub vacuum switch.
5. Turn off the scrub brush with the scrub brush switch.
6. Raise the scrub brush.
7. Raise the rear squeegee.
8. Park the machine next to a floor drain. Turn off the machine and set the parking brake.

FOR SAFETY: Before Leaving Or Servicing Machine; Stop On Level Surface, Set Parking Brake, Turn Off Machine And Remove Key.

OPERATION

9. Open the front access door.
10. Remove the recovery tank drain hose from its retention plug. Lower the hose to the floor drain to drain the tank.

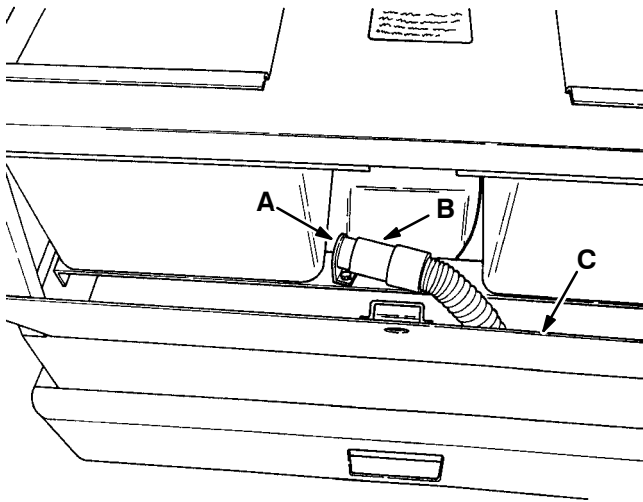

02748

RECOVERY TANK DRAIN HOSE

- A. Plug
- B. Drain Hose
- C. Access Door

11. Replace the hose on the retention plug after the tank is empty.
12. Close the front access door.
13. Start the machine and move the hopper lift and side brush lever to the "RAISE HOPPER" position to empty the debris hopper.
14. Move the hopper lift and side brush lever to the "OFF LOWER HOPPER" position to lower the scrub attachment.

POST OPERATION CHECKLIST – MOTOR OPERATING

Check scrub brush pattern for width and evenness.

Check squeegees for proper deflection.

TO STOP MACHINE

1. Return the directional pedal to the "neutral" position. Apply the brake.
2. Push in the solution flow knobs to stop the solution flow.
3. Pull the main brush position lever into the raised position and raise the side brush and side squeegee with the side brush position lever.
4. Place the hopper lift and side brush lever in the "OFF LOWER HOPPER" position.
5. Turn off the scrub attachment vacuum system with the scrub vacuum switch.
6. Turn off the scrub brush with the scrub brush switch.
7. Raise the scrub brush.
8. Raise the rear squeegee.
9. Set the machine parking brake.

FOR SAFETY: Before Leaving Or Servicing Machine; Stop On Level Surface, Set Parking Brake, Turn Off Machine And Remove Key.

10. Turn off the machine and remove the key.

DOUBLE SCRUBBING OPERATION

Double scrubbing is a method of removing heavy accumulations of soilage, dirt, wax, or spills. It involves making two passes over the area to be cleaned. To double scrub, make a single pass over the surface being cleaned with the rear squeegee raised. Allow the solution to soak on the floor for 15 to 20 minutes. Then make a second scrubbing pass in the normal manner with the rear squeegee lowered.

FOR SAFETY: When Using Machine, Go Slow On Grades And Slippery Surfaces.

MACHINE TROUBLESHOOTING – SWEEPING

PROBLEM	CAUSE	REMEDY
Motor runs but machine will not move.	Foot pedal and/or linkage jammed or not adjusted.	Check pedal and linkage.
	Front wheel jammed or brakes locked.	Check wheels.
	Hydraulic pump drive belts loose or broken.	Adjust or replace belts.
	Hydraulic pump trouble, such as relief valve failure, leakage, etc.	See <i>HYDRAULIC COMPONENT TROUBLESHOOTING</i>
	Rear wheel hydraulic motor trouble such as broken shaft key, broken shaft, etc.	See <i>HYDRAULIC COMPONENTS</i> for parts information.
Machine moves slowly.	Batteries charge is low.	Recharge the batteries.
	Low hydraulic fluid level.	Add hydraulic fluid.
	Front wheels; brakes dragging, wheel jamming, tires softened from contact with oil or solvent.	Check wheels, repair or replace.
	Hydraulic pump drive belts loose.	Tighten belts.
	Hydraulic oil temperature too high – oil too thin. May be caused by operating with excessive load or drag, or worn pump.	Use TENNANT Hydraulic Fluid. Check pump. See <i>HYDRAULIC COMPONENT TROUBLESHOOTING</i> .
	Worn hydraulic pump or rear drive wheel motors.	See <i>HYDRAULIC COMPONENTS</i> for parts information.
Hopper dumps slowly or will not dump.	Pump drive belts loose.	Check belt tension.
	Load in hopper too heavy.	Empty more often.
	Lift arms or hopper binding	Check for binding or obstructions.
	Wear or failure in manually-operated control valve.	Check valve.
	Defective dump cylinder, seals leaking, multi-level dump model.	Repair cylinder.
	Accessory portion of tandem hydraulic pump worn or damaged.	See <i>HYDRAULIC COMPONENTS</i> for parts information.
No vacuum – poor dust pick-up	Dust skirts not adjusted or worn.	Replace or adjust dust skirts.
	Fusible link on filter box fire	Replace fusible link.
	Dust filters clogged.	Clean filters.
	Vacuum fan v-belt slipping or broken.	Replace v-belt.
	Failure in fan drive such as sheave key broken, etc.	Repair sheaves.

OPERATION

PROBLEM	CAUSE	REMEDY
Poor sweeping.	Sweeping brushes not adjusted	Adjust sweeping brushes.
	Sweeping brushes worn	Replace brushes.
	Dust skirts not adjusted or worn.	Replace or adjust dust skirts.
	Filters clogged.	Clean filters.
	Main brush drive belts slipping.	Check both brush drive belts for proper tension.
	Side brush hydraulic motor worn.	Check motor.
	Brush driving plugs worn or damaged.	Check plugs.

MACHINE TROUBLESHOOTING – SCRUBBING

PROBLEM	CAUSE	REMEDY
Trailing water – poor or no water pickup.	Worn rear squeegee.	Rotate or replace rear squeegee blade.
	Rear squeegee out of adjustment.	Adjust rear squeegee.
	Vacuum hose clogged.	Flush vacuum hoses.
	Recovery tank full.	Drain tank.
	Ball float stuck shutting off vacuum.	Clean ball float and float guide.
	Debris caught on squeegee.	Remove debris.
	Debris hopper full.	Empty hopper.
	Foam filling recovery tank.	Empty recovery tank; change detergent.
	Vacuum hose to rear squeegee disconnected or damaged.	Reconnect or replace vacuum hose.
	Vacuum fan to recovery tank hose damaged.	Replace hose.
	Poor vacuum.	Check vacuum fan and motor on scrub attachment.
Water spills from side of scrub attachment.	Side squeegee blade worn or damaged.	Replace side squeegee blade.
	Too much solution being applied.	Turn off solution flow 5 to 10 feet before making a turn.
Little or no solution flow to floor.	Solution tank empty.	Fill solution tank.
	Water valve cables broken or jammed.	Replace or free cables
	Solution supply lines and spreader tube clogged.	Flush solution supply lines, spreader tube.
	Solution flow knobs pushed in.	Pull flow knob out to start solution flow.
Poor scrubbing performance	Debris caught on scrub brushes.	Remove debris.
	Improper detergent or brushes used.	Check with TENNANT representative for advice.
	Worn scrub brushes.	Replace scrub brushes.
	Scrub brushes out of adjustment.	Adjust scrub brushes.
	Debris hopper full.	Empty hopper.

TRANSPORTING MACHINE

PUSHING OR TOWING MACHINE

The machine may be pushed from the front or rear. It may be towed only from the rear.

Place a dolly under the rear wheel to travel distances greater than 1 mile (1 km) or speeds over 1 mph (1 km/h).

ATTENTION! Do not push or tow the machine without placing the rear wheel on a dolly or the machine hydraulic system may be damaged.

MACHINE JACKING

The machine may be jacked up for service at the designated locations. Use a jack of adequate capacity and good working condition. Always stop the machine on a flat, level surface and block the tires before jacking the machine up.

The front jacking locations are on the flat bottom edge of the machine frame next to the front tires.

The rear jacking location is the middle flat bottom edge of the rear bumper.

TO JACK UP MACHINE

1. Empty the debris hopper.
2. Turn off the machine and set the machine parking brake.

FOR SAFETY: Before Leaving Or Servicing Machine; Stop On Level Surface, Set Parking Brake, Turn Off Machine And Remove Key.

3. Block the tires, which are not being jacked up, in order to secure the machine position.

FOR SAFETY: When Servicing Machine, Block Machine Tires Before Jacking Machine Up.

4. Use a jack of adequate capacity to raise the machine. Jack up the machine only at the designated locations.

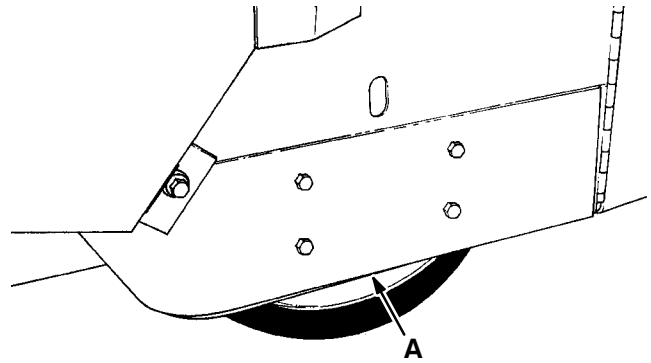

FRONT JACKING LOCATION

00559

A. Jacking Location

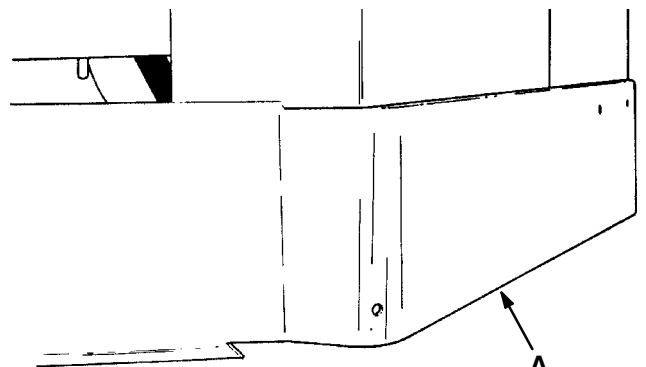

REAR JACKING LOCATION

00571

A. Jacking Location

5. Block machine up with jack stands or similar devices near the designated locations to secure the machine.

FOR SAFETY: When Servicing Machine, Jack Machine Up At Designated Locations Only. Block Machine Up With Jack Stands.

6. Lower the machine onto the jack stands.
7. Check to make sure the machine is secure.
8. Service the machine as required.
9. When finished servicing the machine, raise the machine off the jack stands.
10. Remove the jack stands from under the machine.
11. Lower the machine.
12. Remove the blocks from the tires.

MACHINE STORAGE

STORING MACHINE

When storing the machine for extended periods of time, these procedures must be followed to lessen the chance of rust, sludge, and other undesirable deposits from forming:

1. Empty the debris hopper.
2. Fully charge the batteries.
3. Raise the main brush and side brushes.
4. Park the machine on a level surface in a cool, dry area.

5. Turn off the machine and set the machine parking brake.

FOR SAFETY: Before leaving or servicing machine; stop on level surface, set parking brake, turn off machine and remove key.

6. Check the hydraulic fluid level. It should be up to the full mark on the dipstick to prevent excessive condensation from forming in the reservoir.
7. Disconnect the machine and battery connectors.

OPTIONS

HOPPER DOLLY

The hopper dolly accessory makes the job of removing the low dump model hopper easy. It also is used to store the hopper when it is not mounted on the machine.

TO REMOVE HOPPER WITH DOLLY

1. Empty the hopper.
2. Set the machine parking brake.

FOR SAFETY: Before leaving or servicing machine; stop on level surface, set parking brake, turn off machine and remove key.

3. Raise the hopper, and place the hopper lift and side brush lever in the "HOLD HOPPER" position.
4. Turn off the machine.
5. Roll the hopper dolly under the hopper so the lip on the short end of the dolly is behind the bottom edge of the hopper.

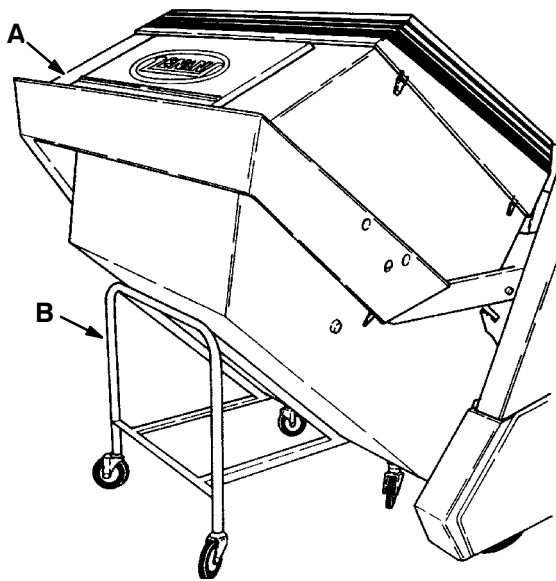

HOPPER DOLLY

02751

- A. Hopper
- B. Dolly

6. Tilt the lift arm hooks back away from the lift arm pins.

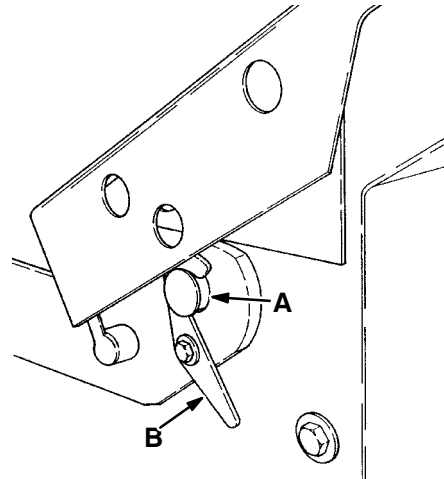

LIFT ARM HOOK

02752

- A. Pin
- B. Hook

7. Place the hopper lift and side brush lever in the "OFF LOWER HOPPER" position to lower the hopper onto the dolly.
8. Disconnect the filter shaker motor wire between the hopper and the machine.
9. Push the lift arms down to clear the lift arm pins and roll the hopper away from the machine.

TO INSTALL HOPPER WITH DOLLY

1. Turn off the machine and set the machine parking brake.

FOR SAFETY: Before Leaving Or Servicing Machine; Stop On Level Surface, Set Parking Brake, Turn Off Machine And Remove Key.

2. Roll the hopper into position in the machine.

NOTE: The right lift arm scrub locking cam must be positioned away from the hopper cam on the lift arm.

3. Connect the shaker motor wire from the hopper to the machine.
4. Start the machine and raise the lift arms so the lift arm slots will make contact with the lift arm pins. Turn off the machine.
5. Position the lift arm pins in the lift arm slots. Push the lift arm hooks over the pins.

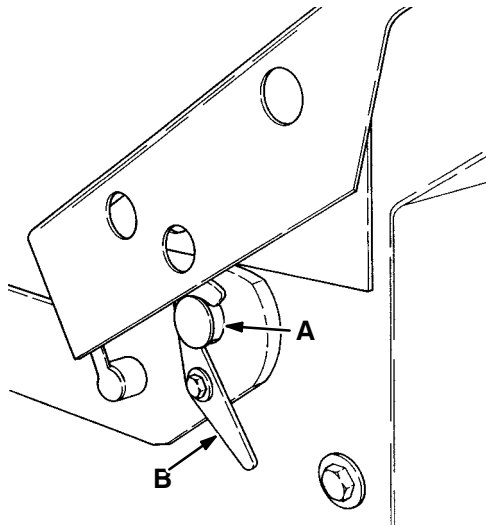

LIFT ARM HOOK

02752

- A. Pin
- B. Hook

6. Start the machine, raise the hopper, and place the hopper lift and side brush lever in the "HOLD HOPPER" position.
7. Engage the hopper support bar.

! WARNING: Raised Hopper May Fall. Engage Hopper Support Bar.

8. Roll the hopper dolly away from the machine.
9. Raise the hopper and place the hopper support bar in its storage location. Lower the hopper.
10. Turn off the machine.

SCRUB ATTACHMENT

The scrub attachment accessory gives the machine the added flexibility to scrub floors. It consists of three groups of parts – the scrub attachment, the side scrub brush and squeegee, and the rear squeegee.

The scrub attachment and side scrub brush and squeegee are to be removed when sweeping. The rear squeegee may be left on the machine, if the rear squeegee is raised during machine operation. The scrub attachment takes the place of the sweeping hopper. The side scrub brush and squeegee take the place of the side sweep brush. The main sweeping brush is also exchanged for a scrubbing variety brush in the conversion.

TO MOUNT SCRUB ATTACHMENT

1. Remove debris hopper with hopper dolly as described in *TO REMOVE HOPPER WITH DOLLY*.
2. Lower the lift arms.
3. Turn off the machine and set the machine parking brake.

FOR SAFETY: Before Leaving Or Servicing Machine; Stop On Level Surface, Set Parking Brake, Turn Off Machine And Remove Key.

4. Roll the scrub attachment into position in the machine leaving enough room to connect the electric cables.

ATTENTION! The solution and recovery tanks must be empty during scrub attachment installation and removal to avoid personal injury.

5. Connect the electric cable and the single wire between the scrub attachment and the machine.

OPERATION

6. Push the scrub attachment into place so the lift pins on the scrub attachment line up with the pin slots on the lift arms. Push the lift arm hooks over the pins.

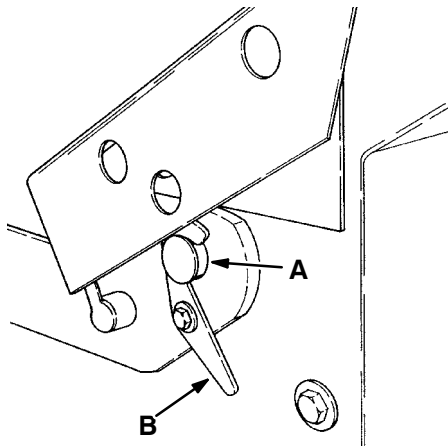

LIFT ARM HOOK

02752

- A. Pin
- B. Hook

7. Start the machine and raise the scrub attachment slightly.
8. Pull out the locking knobs on the two (2) front support legs, swing the legs up and release the knobs.
9. Lower the scrub attachment.
10. Lower the front bumper.
11. Raise the scrub attachment. Engage the hopper support bar. Turn off the machine.

 **WARNING: Raised Hopper May Fall. Engage Hopper Support Bar.**

12. Pull out the locking knobs on the two (2) rear support legs, swing the legs up and release the knobs.

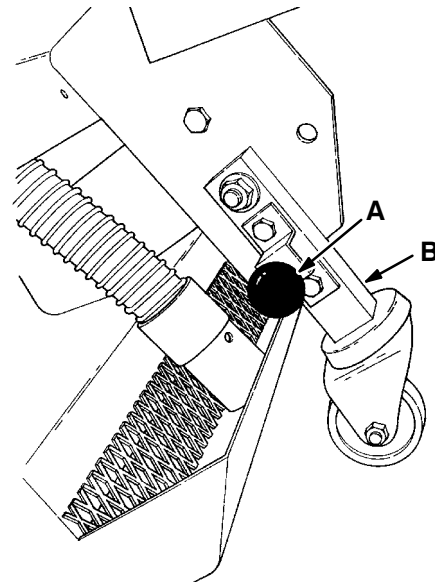

SCRUB ATTACHMENT LEG

02754

- A. Locking Knob
- B. Support Leg

13. Loosen the scrub locking cam on the right lift arm, and rotate it snug against the bracket on the scrub attachment. Tighten the cam bolt.
14. Check to see that the solution recovery hose is mounted in the debris trough.
15. Start the machine and raise the scrub attachment. Place the hopper support bar in its storage location and lower the scrub attachment.
16. Slide the side brush squeegee assembly into position in the squeegee bracket.
17. Slide the two squeegee retaining pins through the bracket and squeegee assembly.

- Pull the pin keeper out, turn the squeegee retaining pins so they are under the pin keeper, and release the keeper.

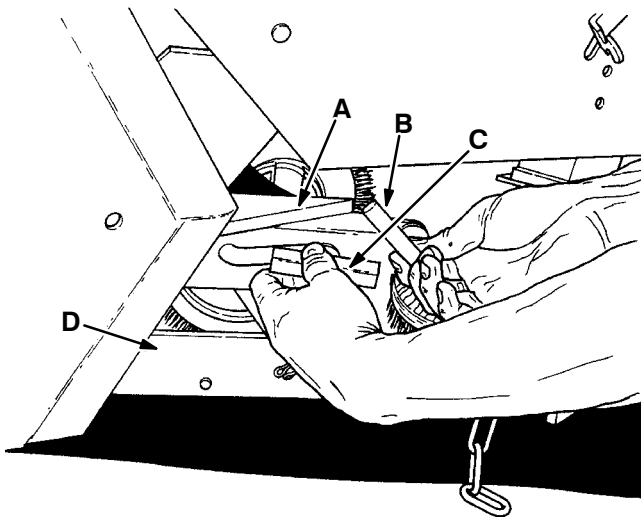

02757

SECURING SQUEEGEE RETAINING PINS

- A. Bracket**
- B. Retaining Pin**
- C. Pin Keeper**
- D. Squeegee Assembly**

- Connect the squeegee assembly chain to the chain hook.

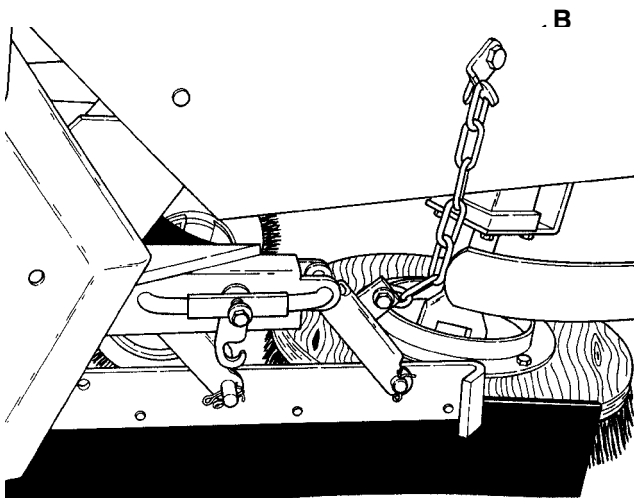

02758

SQUEEGEE ASSEMBLY CHAIN

- A. Chain**
- B. Hook**
- C. Squeegee Assembly**

- Replace the side brush with a scrubbing side brush as described in *TO REPLACE SIDE BRUSH*.
- Replace the main brush with a scrubbing main brush as described in *TO REPLACE MAIN BRUSH*.

TO REMOVE SCRUB ATTACHMENT

- Drain the scrub attachment solution and recovery tanks.

ATTENTION! The solution and recovery tanks must be empty during scrub attachment installation and removal to avoid personal injury.

- Drive the machine to the scrub attachment storage area.
- Turn off the machine and set the machine parking brake.

FOR SAFETY: Before Leaving Or Servicing Machine; Stop On Level Surface, Set Parking Brake, Turn Off Machine And Remove Key.

- Disconnect the squeegee assembly chain from the chain hook.

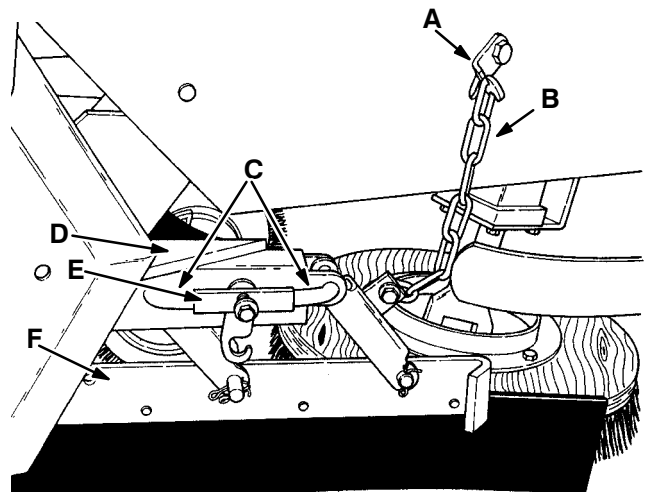

02758

SQUEEGEE ASSEMBLY

- A. Hook**
- B. Chain**
- C. Retaining Pin**
- D. Bracket**
- E. Pin Keeper**
- F. Squeegee Assembly**

OPERATION

5. Pull the retaining pin keeper out and remove the two squeegee assembly retaining pins. Release the pin keeper.
6. Slide the squeegee assembly out from the machine.
7. Start the machine, raise the scrub attachment, and engage the hopper support bar. Turn off the machine.

! WARNING: Raised Hopper May Fall. Engage Hopper Support Bar.

8. Pull out locking knobs on the two (2) rear support legs, swing the legs down into the "down" position, and release the knobs.

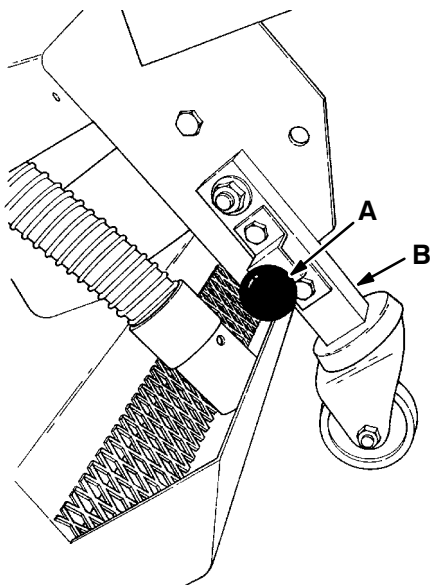

SCRUB ATTACHMENT LEG

02754

- A. Locking Knob
- B. Leg

9. Loosen the scrub locking cam on the right lift arm, and rotate it away from the bracket on the scrub attachment, to free the scrub attachment. Tighten the cam bolt.
10. Start the machine, raise the scrub attachment, place the hopper support bar in its storage location, and lower the scrub attachment. Turn off the machine.
11. Raise the front bumper.
12. Start the machine, raise the scrub attachment slightly.

13. Pull out locking knobs on the two (2) front support legs, swing the legs down into the "down" position, and release the knobs.
14. Lower the scrub attachment to the floor. Turn off the machine.
15. Tilt the lift arm hooks back away from the lift arm pins.

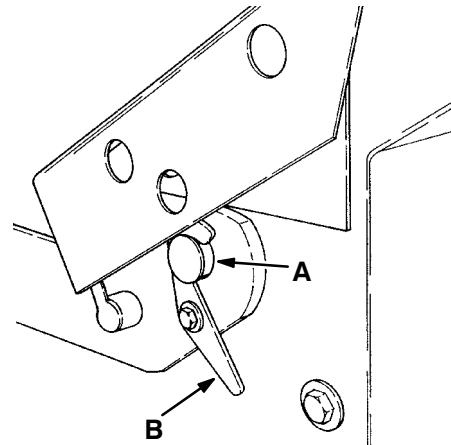

LIFT ARM HOOK

02752

- A. Pin
- B. Hook

16. Push the lift arms down to clear the lift arm pins.
17. Disconnect the electric cable and the single wire between the scrub attachment and the machine.
18. Roll the scrub attachment out of the machine to its storage location.
19. Replace the side scrub brush with a sweeping variety side brush as described in *TO REPLACE SIDE BRUSH*.
20. Replace the main brush with a sweeping variety main brush as described in *TO REPLACE MAIN BRUSH*.
21. Install the hopper as described in *TO INSTALL THE HOPPER WITH DOLLY*.

SECTION 3

CONTENTS

	Page		Page
RECOMMENDED FIRST 50-HOUR MACHINE INSPECTION	3-3	ELECTRICAL SYSTEM	3-19
MAINTENANCE CHART	3-4	BATTERIES	3-19
LUBRICATION	3-6	BATTERY CHARGING	3-20
REAR WHEEL SUPPORT	3-6	TO CHARGE BATTERIES	3-20
STEERING GEAR	3-6	ELECTRIC MOTORS	3-21
FRONT WHEEL BEARINGS	3-6	ELECTRIC SCHEMATIC	3-22
HOPPER LIFT ARM PIVOTS	3-7	BELTS AND CHAINS	3-23
HOPPER DOOR LATCHES	3-7	PUMP BELT	3-23
COUNTERSHAFT BELT IDLER	3-8	TO REPLACE PUMP BELT	3-23
SCRUB ATTACHMENT SCRUB BRUSH GEAR	3-8	COUNTERSHAFT BELT	3-23
SCRUB ATTACHMENT LEG CASTERS	3-8	MAIN BRUSH BELT	3-24
SCRUB ATTACHMENT DEBRIS HOPPER	3-8	VACUUM FAN BELT	3-24
HYDRAULICS	3-9	SCRUB ATTACHMENT VACUUM FAN BELT	3-24
HYDRAULIC FLUID	3-9	STATIC DRAG CHAIN	3-24
HYDRAULIC FLUID RESERVOIR	3-9	DEBRIS HOPPER	3-25
TO DRAIN THE HYDRAULIC FLUID RESERVOIR	3-10	HOPPER DUST FILTER	3-25
TO FILL THE HYDRAULIC FLUID RESERVOIR	3-10	TO REMOVE HOPPER DUST FILTER	3-25
HYDRAULIC FLUID RESERVOIR BREATHER	3-10	TO INSTALL HOPPER DUST FILTER	3-26
HYDRAULIC FLUID FILTER	3-10	HOPPER FUSIBLE LINK	3-26
TO REPLACE HYDRAULIC FLUID FILTER ELEMENT	3-10	TO REPLACE HOPPER FUSIBLE LINK	3-26
HYDRAULIC PUMPS	3-11	DEBRIS HOPPER	3-27
TO START AND BREAK-IN HYDRAULIC PUMP	3-11	TO ADJUST LOW DUMP MODEL HOPPER	3-27
DIRECTIONAL PEDAL	3-12	TO ADJUST MULTI-LEVEL DUMP MODEL HOPPER	3-27
TO ADJUST DIRECTIONAL PEDAL NEUTRAL POSITION	3-12	BRUSHES	3-31
SPEED LIMITER	3-13	MAIN BRUSH	3-31
HYDRAULIC FLUID LEAKS	3-13	TO REPLACE MAIN BRUSH	3-31
HYDRAULIC COMPONENTS TROUBLESHOOTING	3-14	TO CHECK AND ADJUST MAIN BRUSH PATTERN	3-31
HYDRAULIC SCHEMATIC, LOW DUMP (For machines below serial number 005106)	3-15	SIDE BRUSH	3-32
HYDRAULIC SCHEMATIC, LOW DUMP (For machines serial number 005106 and above)	3-16	TO REPLACE SIDE BRUSH	3-33
HYDRAULIC SCHEMATIC, MULTI-LEVEL DUMP (For machines below serial number 005106)	3-17	SKIRTS AND SEALS	3-34
HYDRAULIC SCHEMATIC, MULTI-LEVEL DUMP (For machines serial number 005106 and above)	3-18	HOPPER LIP SKIRTS	3-34
		TO REPLACE HOPPER LIP SKIRTS	3-34
		BRUSH DOOR AND SIDE SKIRTS	3-34
		TO REPLACE AND ADJUST BRUSH DOOR SKIRT	3-34
		TO REPLACE AND ADJUST SIDE SKIRT	3-35
		REAR SKIRT	3-35
		TO REPLACE AND ADJUST THE REAR SKIRT	3-35
		MAIN BRUSH DOOR SEALS	3-35
		HOPPER SEALS	3-36
		HOPPER INSPECTION DOOR SEAL	3-36
		HOPPER DOOR SEALS	3-36
		HOPPER COVER SEAL	3-36
		HOPPER VACUUM FAN SEAL	3-37

MAINTENANCE

	Page
BRAKES AND TIRES	3-38
SERVICE BRAKES	3-38
TO ADJUST BRAKE LINKAGE	3-38
TIRES	3-38
OPTIONS	3-39
SCRUB ATTACHMENT	3-39
SOLUTION TANKS	3-39
SOLUTION DISTRIBUTION SYSTEM	3-39
SCRUB BRUSHES	3-39
TO REPLACE SCRUB BRUSH	3-40
TO CHECK AND ADJUST SCRUB BRUSH PATTERN	3-41
RECOVERY TANK	3-42
TO DRAIN THE RECOVERY TANK	3-42
TO CLEAN THE RECOVERY TANK	3-43
DEBRIS HOPPER	3-43
SIDE SQUEEGEE	3-44
TO REPLACE SIDE SQUEEGEE BLADE	3-44
REAR SQUEEGEE	3-45
TO REPLACE OR ROTATE REAR BLADE	3-45
TO CHECK AND ADJUST REAR SQUEEGEE	3-47

RECOMMENDED FIRST 50-HOUR MACHINE INSPECTION

After the first 50 hours of operation, the following procedures are recommended:

1. Check the floor skirts to floor clearance. See *SKIRTS AND SEALS* in the *MAINTENANCE* section.
2. Check the side brush pattern and main brush patterns. See *BRUSHES* in the *MAINTENANCE*.
3. Torque the rear wheel nuts.
4. Perform all 50-hour interval lubrication and maintenance procedures listed in the *MAINTENANCE CHART*.

MAINTENANCE CHART

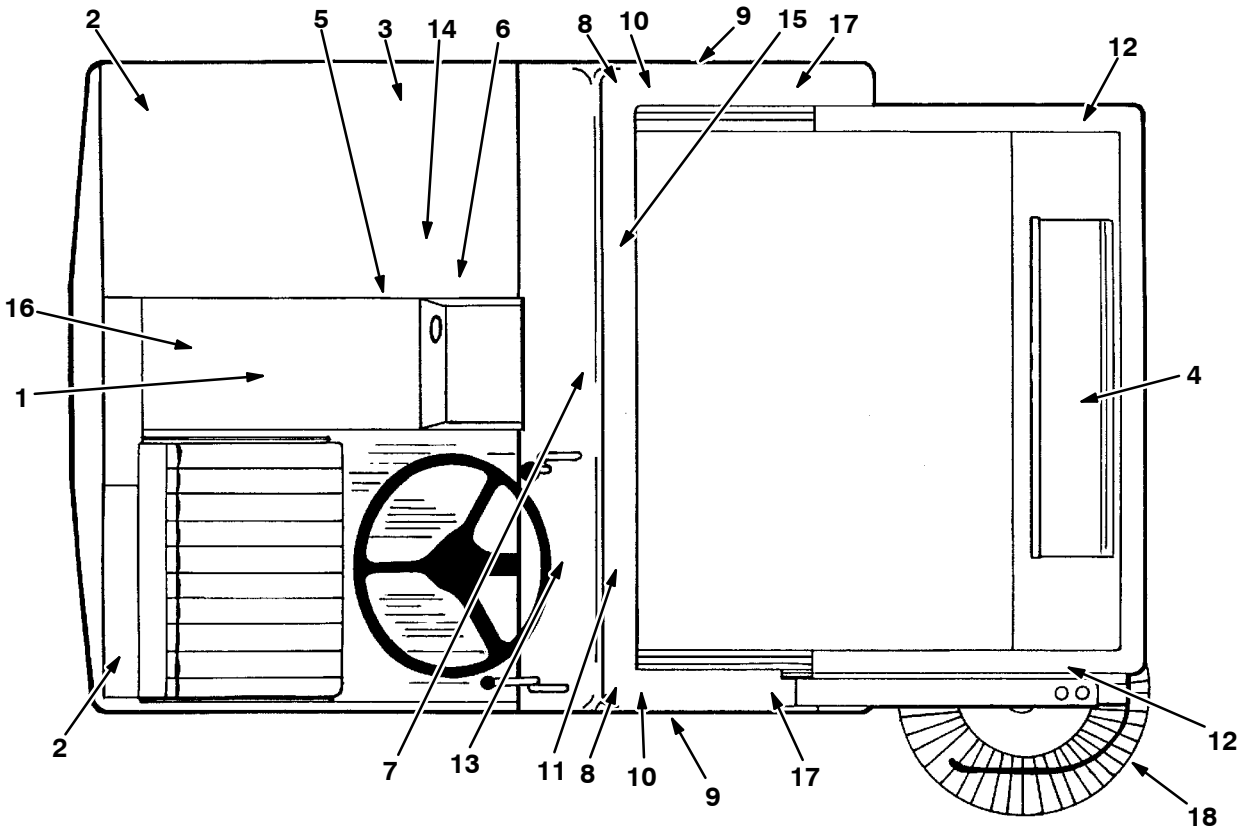

05183

Interval	Key	Description	Procedure	Lubricant	No. of Service Points
Daily	9	Floor skirts	Check for damage, wear and adjustment	—	5
	7	Main brush	Check for damage, wear, and adjustment	—	1
	18	Side brush	Check for damage, wear, and adjustment	—	1
	--	Scrub attachment	Check squeegee for damage, wear, and adjustment	—	1
			Check scrub brush for damage, wear, and adjustment	—	1
		Lubricate debris hopper pivots	SPL	2	
50 Hours	8	Hopper lift arm pivots	Lubricate	SPL	2
	3	Countershaft belt idler	Lubricate	SPL	1
	7	Main brush	Rotate end-for-end	—	1
	6	Pump belt	Check condition	—	1
	5	Vacuum fan belt	Check condition	—	1
	3	Main brush belt	Check tension and condition	—	1
	3	Countershaft belt	Check tension and condition	—	1
	--	Scrub attachment, EE	Check tension and condition of vacuum fan belt	—	1
	2	Batteries	Check electrolyte level	—	2

MAINTENANCE

Interval	Key	Description	Procedure	Lubricant	No. of Service Points
100 Hours	11	Steering gear case	Check grease level	GL ₁	1
	1	Hydraulic fluid reservoir	Check fluid level	HYDO	1
	10	Dust seals	Check for damage or wear	–	8
	2	Batteries	Check charge	–	2
	--	Scrub attachment	Check lubricant level in main scrub brush drive gear box	GL ₂	1
	4 17	Hopper fusible link Tires	Check installation Check for wear	– –	1 2
200 Hours	12	Hopper door latches, multi-level dump model	Lubricate	SPL	2
	13	Brake pedal	Check and adjust travel	–	1
	--	Scrub attachment	Lubricate casters	SPL	4
250 Hours	14	Propelling motor	Check brushes	–	1
	--	Scrub attachment	Check brushes on scrub brush and vacuum fan motors	–	2
500 Hours	1	Hydraulic fluid reservoir	Change hydraulic fluid	HYDO	1
	15	Hydraulic fluid filter	Change filter element	–	1
	16	Rear wheel support bearing	Lubricate	SPL	1
	17	Front wheel bearings	Inspect and lubricate	SPL	2
800 Hours	1	Hydraulic fluid reservoir	Replace breather cap	–	1

GL₁ – SAE 90 weight gear lubricant

GL₂ – SAE 140 weight gear lubricant

HYDO – TENNANT or approved hydraulic fluid

SPL – Special lubricant, Lubriplate EMB grease (TENNANT part no. 01433–1).

NOTE: More frequent intervals may be required in extremely dusty conditions.

LUBRICATION

REAR WHEEL SUPPORT

The rear wheel support pivots the rear wheel. Hand-pack the rear wheel support bearing after every 500 hours of operation. Use Lubriplate EMB grease (TENNANT part no. 01433-1).

STEERING GEAR

The steering gear controls the steering arm. A square head plug has been provided on the front side of the steering gear to check the grease level and to allow filling.

Check the steering grease level after every 100 hours of operation. Fill the unit with SAE 90 weight gear lubricant.

FRONT WHEEL BEARINGS

The front wheel bearings support the front half of the machine. Inspect the bearings for contamination, seal damage, and repack after every 500 hours of operation. Use Lubriplate EMB grease (TENNANT part no. 01433-1).

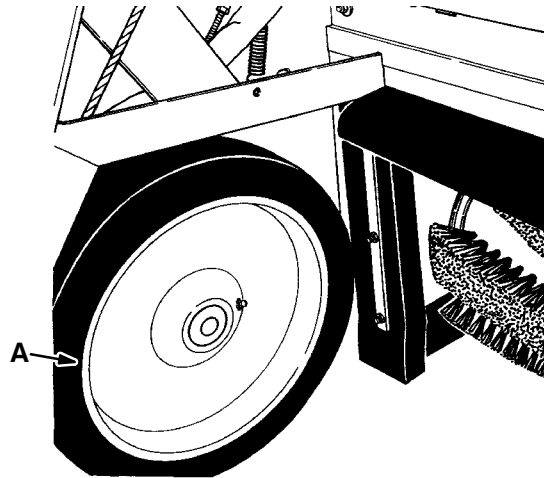

FRONT WHEEL

A. Wheel

02457

HOPPER LIFT ARM PIVOTS

The hopper lift bearings support the lift arm pivots. Two grease fittings are used to lubricate the hopper lift bearings. One grease fitting is located on each of the hopper lift bearings.

Access to the left side grease fitting is through the battery cover. The right side grease fitting is exposed to the operator compartment.

Lubricate the bearings with a grease gun after every 50 hours of operation. Use Lubriplate EMB grease (TENNANT part no. 01433-1).

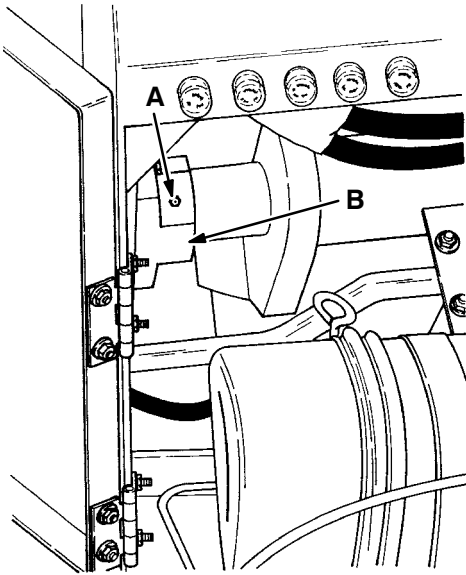
**LEFT SIDE HOPPER LIFT BEARING**

- A. Grease Fitting
- B. Lift Bearing

02478

HOPPER DOOR LATCHES

The hopper door latches latch the hopper door on multi-level dump model machines. Two grease fittings are used to lubricate the hopper door latches. One grease fitting is on each of the latches.

To gain access to the latch grease fittings, raise and roll out the hopper.

Lubricate the latches with a grease gun after every 200 hours of operation. Use Lubriplate EMB grease (TENNANT part no. 01433-1).

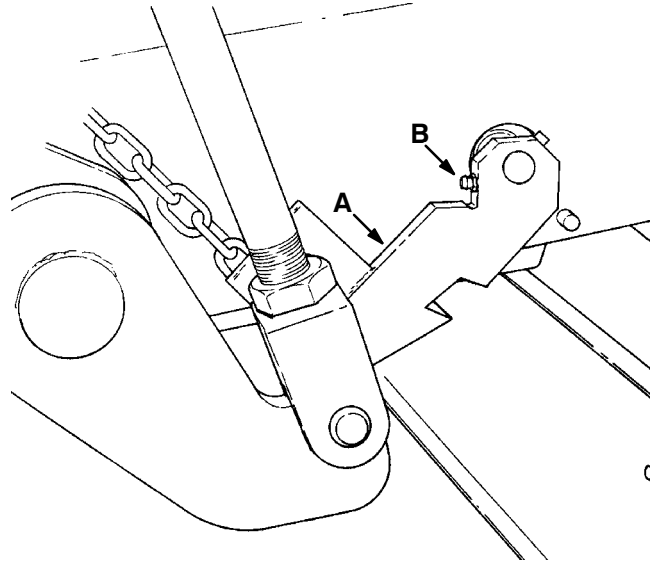
**HOPPER DOOR LATCH**

- A. Hopper Door Latch
- B. Grease Fitting

00550

MAINTENANCE

COUNTERSHAFT BELT IDLER

The countershaft belt idler keeps tension on the v-belt from the electric motor to the countershaft. A grease fitting is mounted on the end of the idler arm. Lubricate the idler with a grease gun after every 50 hours of operation. Use Lubriplate EMB grease (TENNANT part no. 01433-1).

SCRUB ATTACHMENT SCRUB BRUSH GEAR

The scrub brush gear transfers power from the electric motor to the scrub brush. Check the lubricant level after every 100 hours of operation. Fill the unit with SAE 140 weight gear lubricant.

SCRUB ATTACHMENT LEG CASTERS

The scrub attachment casters support the scrub attachment when it is not mounted to the machine. A grease fitting is mounted to the axle of each of the four casters. Lubricate the casters with a grease gun after every 200 hours of operation. Use Lubriplate EMB grease (TENNANT part no. 01433-1).

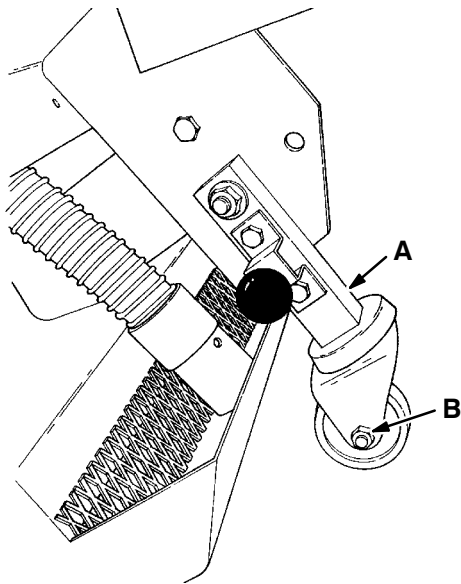

LEG CASTER

02754

- A. Leg
- B. Grease Fitting

SCRUB ATTACHMENT DEBRIS HOPPER

The scrub attachment debris hopper collects debris picked up by the scrub brushes. The debris hopper pivots on two bearings. Each bearing is equipped with a grease fitting. Lubricate the bearings with a grease gun daily. Use Lubriplate EMB grease (TENNANT part no. 01433-1).

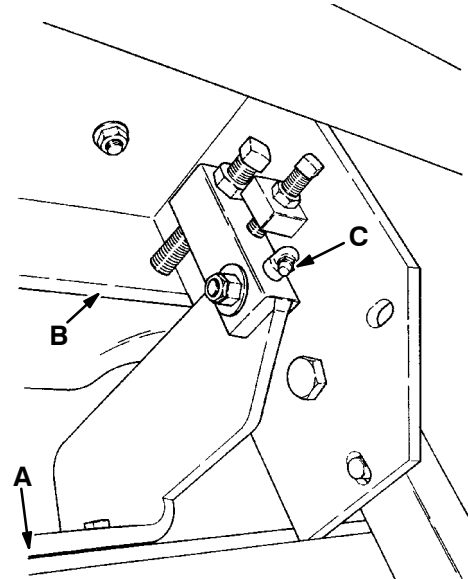

DEBRIS HOPPER

02764

- A. Hopper
- B. Scrub Attachment Frame
- C. Grease Fitting

HYDRAULICS

HYDRAULIC FLUID

The quality and condition of the hydraulic fluid plays a very important role in how well the machine operates. TENNANT’s hydraulic fluid is designed to meet the special needs of its machines.

TENNANT’s hydraulic fluids provide longer life of the hydraulic components. There are two fluids available for two different temperature ranges:

TENNANT part no.	Ambient Temperatures
65869	above 45° F (7° C)
65870	below 45° F (7° C)

The higher temperature fluid is designed with a higher viscosity and should not be used at the lower temperatures. Possible damage to the hydraulic pumps may occur because of improper lubrication.

The lower temperature fluid is a thinner fluid designed for colder temperatures.

If a locally-available hydraulic fluid is preferred, or if products of only one oil company are used, contact TENNANT Technical Customer Service to check the specifications of the substitute fluid. Using substitute fluids can cause premature failure of hydraulic components.

ATTENTION! Hydraulic components depend on system hydraulic fluid for internal lubrication. If dirt or other contaminants are allowed to enter the hydraulic system, malfunctions, accelerated wear, and damage will result.

HYDRAULIC FLUID RESERVOIR

Hydraulic fluid is stored in the hydraulic fluid reservoir. The reservoir holds 5 gal (19 L) of hydraulic fluid. The reservoir is located to the left of the operator seat.

A breather-filler cap and fluid level dipstick is mounted on top of the reservoir. The breather relieves excess pressure in the reservoir. The breather should be replaced after every 800 hours of operation.

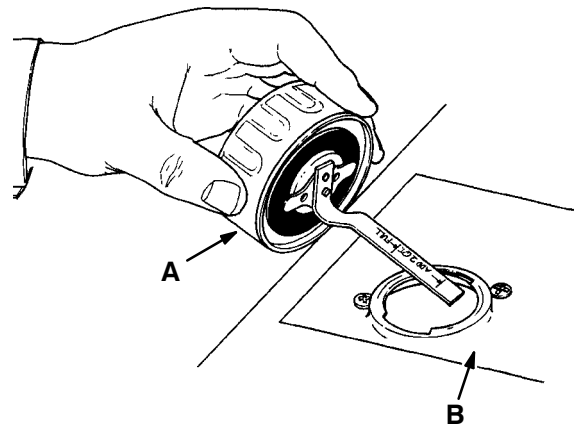

05543

RESERVOIR BREATHER-FILLER CAP

- A. Breather-Filler Cap
- B. Hydraulic Fluid Reservoir

The hydraulic fluid level dipstick is built into the breather-filler cap. The end of the dipstick is marked with “FULL” and “ADD” levels. This indicates the level of hydraulic fluid in the reservoir. The hopper must be lowered when checking reservoir fluid level.

Check the hydraulic fluid level after every 100 hours of operation. It should be above the “ADD” marks on the dipstick, but not above the “FULL” mark when the hydraulic fluid is warm.

MAINTENANCE

Do not overfill the hydraulic fluid reservoir. Hydraulic fluid expands as it heats to its normal operating temperature. Always allow for expansion when filling the reservoir.

ATTENTION! Do not overfill the hydraulic fluid reservoir or operate the machine with a low level of hydraulic fluid in the reservoir. Damage to the machine hydraulic system may result.

Drain and refill the hydraulic fluid reservoir with hydraulic fluid after every 500 hours of operation.

The hydraulic system is kept clean to a level of 10 microns by a hydraulic fluid filter. The hydraulic fluid filter is located below the lintel and behind the hopper. Replace the filter element after every 500 hours of operation.

TO DRAIN THE HYDRAULIC FLUID RESERVOIR

1. Turn off the machine and set the machine parking brake.

FOR SAFETY: Before Leaving Or Servicing Machine; Stop On Level Surface, Set Parking Brake, And Turn Off Machine And Remove Key.

2. Allow the hydraulic fluid to cool.
3. Lift the operator seat.
4. Remove the reservoir drain plug located on the bottom of the reservoir. Discard the used hydraulic fluid.

NOTE: Always change the hydraulic fluid filter when draining the hydraulic fluid reservoir.

5. Flush the reservoir with clean hydraulic fluid or suitable solvent. Do not use gasoline, kerosene, or diesel fuel.
6. Reinstall the reservoir drain plug.
7. Lower the operator seat.

TO FILL THE HYDRAULIC FLUID RESERVOIR

1. Lift the reservoir access door.
2. Remove the reservoir breather-filler cap.

3. Pour 5 gal (19 L) of new, approved hydraulic fluid through a 200 mesh screened funnel and into the reservoir filler neck.

ATTENTION! Use only new, approved hydraulic fluid to fill the hydraulic fluid reservoir.

4. Check the level in the reservoir with the reservoir dipstick.
5. Add hydraulic fluid until the level in the reservoir is between the "ADD" and "FULL" range. Do not overfill.

NOTE: Do not overfill the hydraulic fluid reservoir. As hydraulic fluid heats to its normal operating temperature, it expands. Always allow for this expansion when filling the hydraulic fluid reservoir.

6. Place the reservoir breather-filler cap securely on the reservoir.
7. Close reservoir access door.
8. Start the machine and operate all the hydraulic components. Then recheck the hydraulic fluid level. Add fluid if necessary to bring the level to between the "ADD" and "FULL" range on the reservoir dipstick.

HYDRAULIC FLUID RESERVOIR BREATHER

The hydraulic fluid reservoir is equipped with a breather. The breather relieves excess pressure in the reservoir. The breather is mounted on the hydraulic fluid reservoir. The breather should be replaced after every 800 hours of operation.

HYDRAULIC FLUID FILTER

The machine hydraulic system is kept clean to a level of 10 microns by a hydraulic fluid filter. The hydraulic fluid filter is located below the lintel and behind the hopper.

Replace the hydraulic fluid filter element after every 500 hours of operation.

TO REPLACE HYDRAULIC FLUID FILTER ELEMENT

1. Turn off the machine and set the machine parking brake.

FOR SAFETY: Before Leaving Or Servicing Machine; Stop On Level Surface, Set Parking Brake, And Turn Off Machine And Remove Key.

2. Unthread and discard the hydraulic fluid filter element.

An older style hydraulic filter contained a filter cartridge. Remove the outer case and discard the cartridge.

NOTE: Be aware the hydraulic filter is below the top of the hydraulic fluid reservoir. Some hydraulic fluid will drain from the reservoir. Discard all hydraulic fluid drained from the system. Drained hydraulic fluid may contain foreign material harmful to the hydraulic system.

3. Apply a thin coat of hydraulic fluid to the seal of the new hydraulic fluid filter element.
4. Thread and hand tighten the new hydraulic fluid filter element on the filter head.

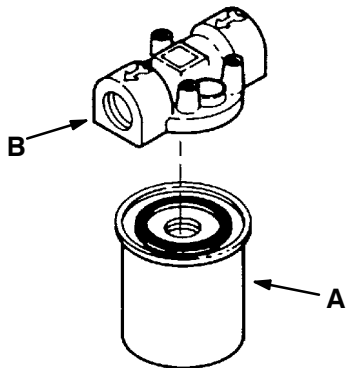

HYDRAULIC FLUID FILTER

05538

- A. Element**
- B. Filter Head**

5. Operate the machine and check for leaks. Correct any leaks found.
6. Check the hydraulic fluid reservoir level and fill as required.

HYDRAULIC PUMPS

The machine propelling pump is a variable displacement hydraulic piston pump. It is driven by the electric motor via a v-belt.

The machine accessories pump is a hydraulic gear pump. It is tandem mounted to the hydraulic piston pump.

After repairing or replacing a hydraulic pump, or when system contamination is likely, change the hydraulic fluid in the reservoir and the hydraulic fluid filter. Then the proper start and break-in procedure must be followed to prevent possible damage to the pump. *TO START AND BREAK-IN HYDRAULIC PUMP* outlines the procedure.

TO START AND BREAK-IN HYDRAULIC PUMP

1. Turn off the machine, set the machine parking brake, and block the front tire of the machine.

FOR SAFETY: Before Leaving Or Servicing Machine; Stop On Level Surface, Set Parking Brake, And Turn Off Machine And Remove Key.

FOR SAFETY: When Servicing Machine, Block Machine Tires Before Jacking Machine Up.

2. Jack up the rear of the machine at the designated locations.

FOR SAFETY: When Servicing Machine, Jack Machine Up At Designated Locations Only. Block Machine Up With Jack Stands.

3. Block up the machine with jack stands near the designated locations. Make sure the rear tire clears the floor by 2 in (50 mm) and the floor is cleared of all obstacles within a 24 in (610 mm) radius.
4. Fill the hydraulic fluid reservoir with 5 gal (19 L) of new, approved hydraulic fluid.
5. Fill the hydraulic pump through the case drain port with hydraulic fluid.
6. Start the machine.
7. Press the directional control pedal one-half of its travel in the “forward” direction while also operating the hydraulics for one minute.

MAINTENANCE

8. Stop the machine.
9. Raise the rear of the machine, remove the jack stands, and lower the machine.
10. Fill the hydraulic fluid reservoir with new, approved hydraulic fluid.
11. Check for system leaks. Correct any leaks found.
12. Replace the hydraulic fluid filter after the first hour of operation.

DIRECTIONAL PEDAL

The directional pedal controls the flow of hydraulic fluid to the hydraulic drive motor. The pedal has three positions – “forward,” “neutral,” and “reverse.” The “forward” and “reverse” positions sends hydraulic fluid to the drive motor to propel the machine.

The “neutral” position is the position in which the propelling pump sends no hydraulic fluid to the propelling motor. The machine should not creep when the “neutral” position is correctly adjusted. Adjust the directional pedal linkages whenever the machine creeps or after replacing the hydraulic propelling pump or pump linkages.

TO ADJUST DIRECTIONAL PEDAL NEUTRAL POSITION

1. Turn off the machine and set the machine parking brake.

FOR SAFETY: Before Leaving Or Servicing Machine; Stop On Level Surface, Set Parking Brake, And Turn Off Machine And Remove Key.

2. Block the machine tires and jack up the rear of the machine at the designated locations.

FOR SAFETY: When Servicing Machine, Block Machine Tires Before Jacking Machine Up.

3. Block up the machine with hack stands near the designated locations. Make sure the rear tire clears the floor by 2 in (50 mm) and all obstacles within a 24 in (610 mm) radius.

FOR SAFETY: When Servicing Machine, Jack Machine Up At Designated Locations Only. Block Machine Up With Jack Stands.

4. Start the machine.
5. Move the directional pedal in the “forward” position and release it. The rear wheel should stop rotating as soon as the pedal is released. Turn off the machine and loosen the screws mounting the spring bracket to the machine frame and to adjust as required.

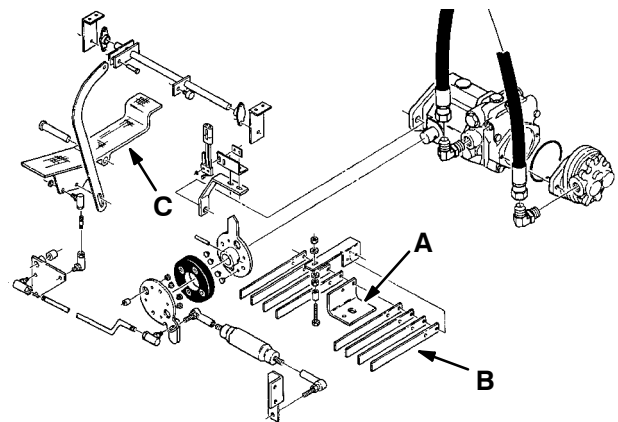

DIRECTIONAL PEDAL ADJUSTMENT

05671

- A. Spring Bracket
- B. Spring
- C. Directional Pedal

6. Move the directional pedal into the “reverse” position and release it. The rear wheel should stop rotating as soon as the pedal is released. Turn off the machine and loosen the screws mounting the spring bracket to the machine frame and to adjust as required.
7. Tighten the mounting screws of the spring bracket.
8. Raise the rear of the machine, remove the jack stands, and lower the machine.

SPEED LIMITER

The speed limiter is present on multi-level dump model machines. It limits the forward speed the machine can travel when the hopper is raised. The speed limiter should be adjusted whenever the directional pedal linkage is adjusted, or after replacing the hydraulic propelling pump or pump linkages. The machine should not travel more than 2 mph (3.2 km/h) with the hopper raised.

The speed limiter is adjusted by loosening the roller cam retaining nut, repositioning the roller cam, and tightening the roller cam retaining nut.

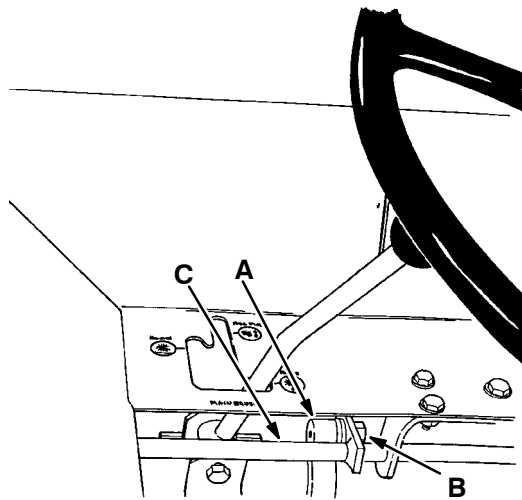

SPEED LIMITER

- A. Speed Limiter Cam**
- B. Retaining Nut**
- C. Pump Linkage**

00574

HYDRAULIC FLUID LEAKS

Fluid escaping from a very small hole can be almost invisible. Use a piece of cardboard or wood, rather than hands, to search for suspected leaks.

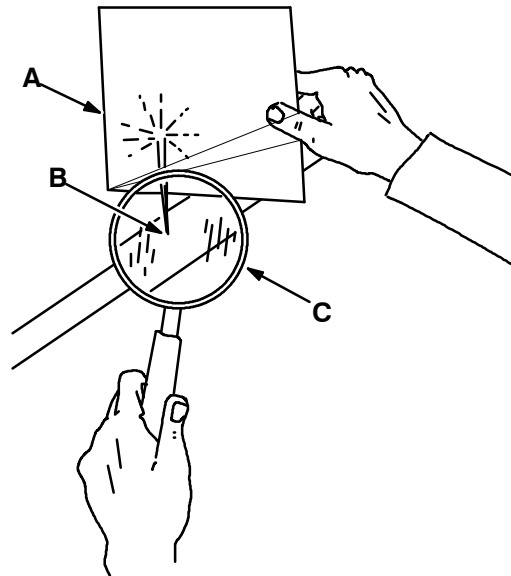

HYDRAULIC PINHOLE LEAK

00002

- A. Cardboard**
- B. Pinhole Leak**
- C. Magnifying Glass**

If injured by escaping hydraulic fluid, see a doctor at once. Serious infection or reaction can develop if proper medical treatment is not administered immediately.

FOR SAFETY: When Servicing Machine, Use Cardboard To Locate Leaking Hydraulic Fluid Under Pressure.

MAINTENANCE

HYDRAULIC COMPONENTS TROUBLESHOOTING

PROBLEM	CAUSE	REMEDY
Hydraulic pump making excessive noise.	Partially clogged pump inlet line.	Check the inlet line to pump and tank inlet. If oil is dirty, drain system and flush thoroughly. Refill with new, approved hydraulic fluid.
	Air leak at pump intake line connections.	Pour fluid on connections to check for leaks – listen for change in pump sound level. Tighten connections which are loose.
	Air bubbles in hydraulic fluid.	Check for low hydraulic fluid or loose connections in hydraulic lines.
	Hydraulic pump is worn or damaged.	Repair or replace pump.
Hydraulic motor operates slowly.	Worn pump.	Repair or replace pump.
	Worn hydraulic motor.	Replace seals and repair motor.
	High hydraulic fluid temperature.	Change to higher viscosity fluid.
	Clogged hydraulic fluid filter.	Change filter element or cartridge.
Hydraulic motor will not turn over.	Shaft seized in housing.	Replace housing and shaft assembly.
	Large contaminating particles in hydraulic fluid.	Flush out system, change fluid and fluid filter.
	Broken shaft.	Replace shaft.
Hydraulic motor runs without turning the shaft.	Broken parts in motor.	Disassemble motor and check parts.
Hydraulic motor leaks at shaft.	Worn or cut shaft seal.	Replace shaft seal. Polish shaft at seal area – check for rough areas or burrs.
Leak between flange and housing in hydraulic motor.	Loose flange screws.	Tighten screw.
	O-Ring worn or damaged.	Replace o-ring.
	Housing plug o-ring leaking. (Side brush motor only.)	Replace plug o-ring.
Leak between housing and plate or plate and gerotor in hydraulic motor.	End cap screws loose.	Tighten end cap screws.
	O-Ring worn or damaged.	Replace o-ring.
Leak between gerotor and end cap.	Dirt between surfaces.	Disassemble, clean parts.
	Scratches, nicks, burrs	Polish parts.
	O-Ring worn or damaged.	Replace o-rings.

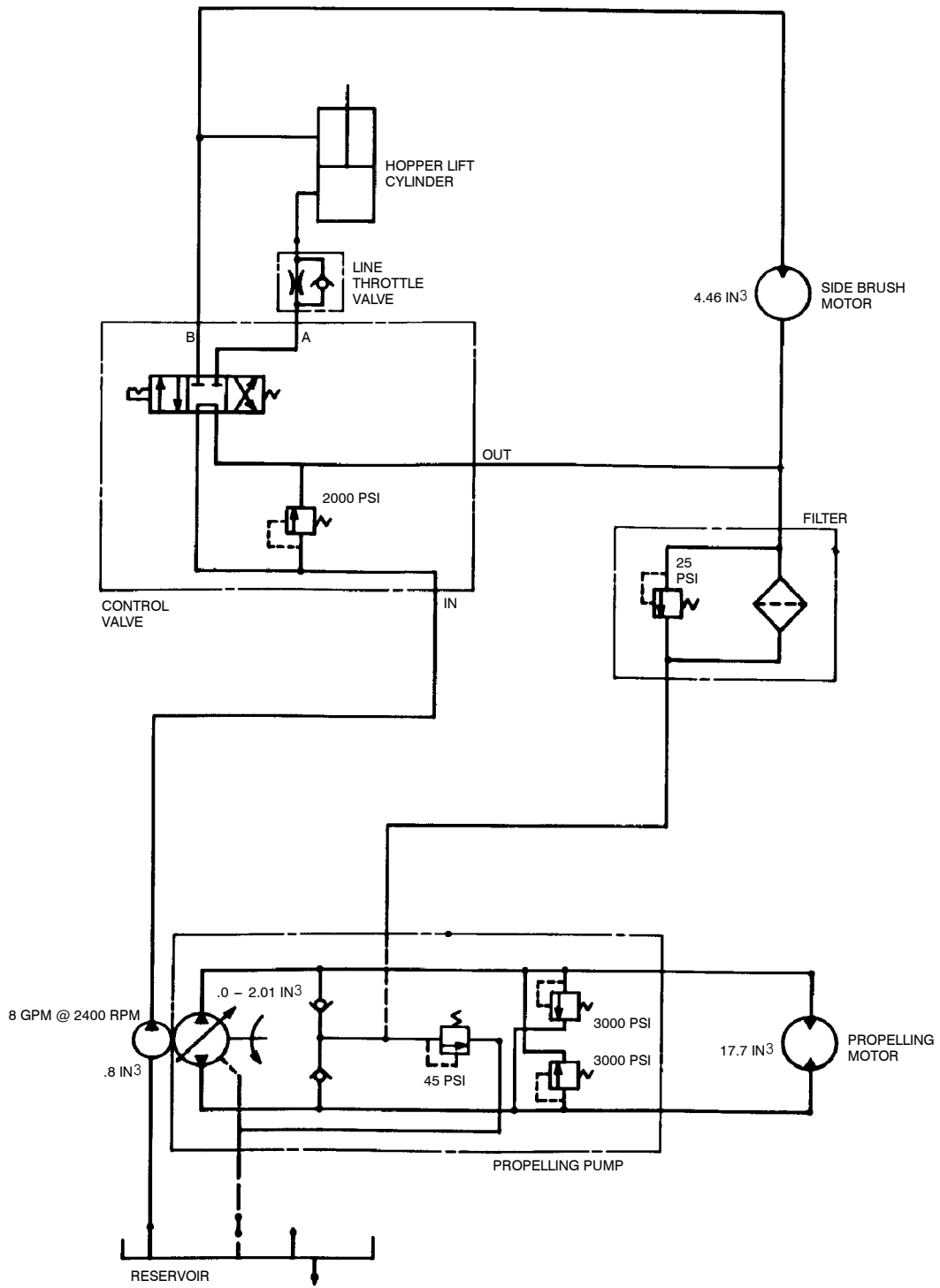

HYDRAULIC SCHEMATIC, LOW DUMP
(For machines below serial number 005106)

05545

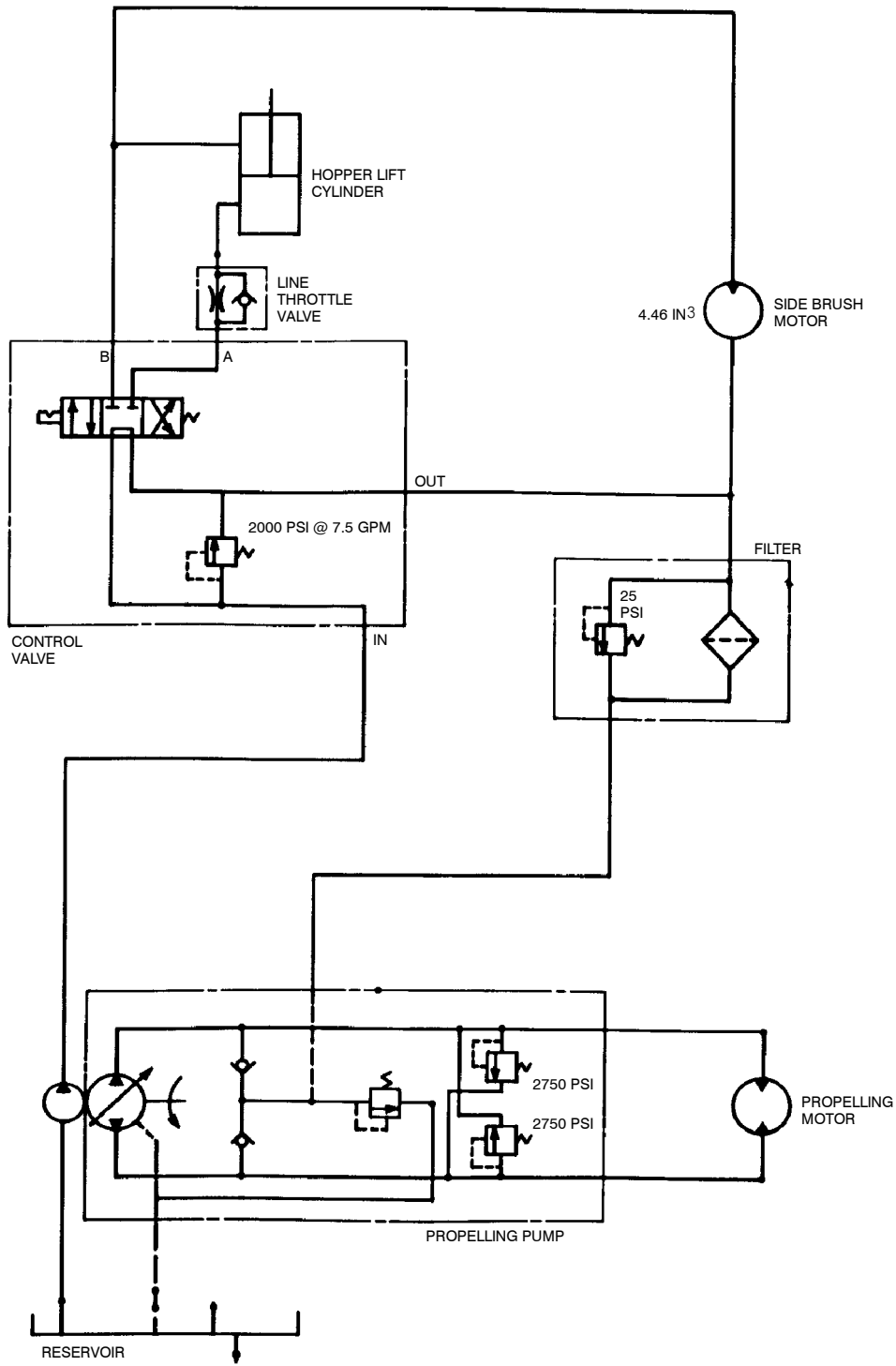

HYDRAULIC SCHEMATIC, LOW DUMP
(For machines serial number 005106 and above)

07399

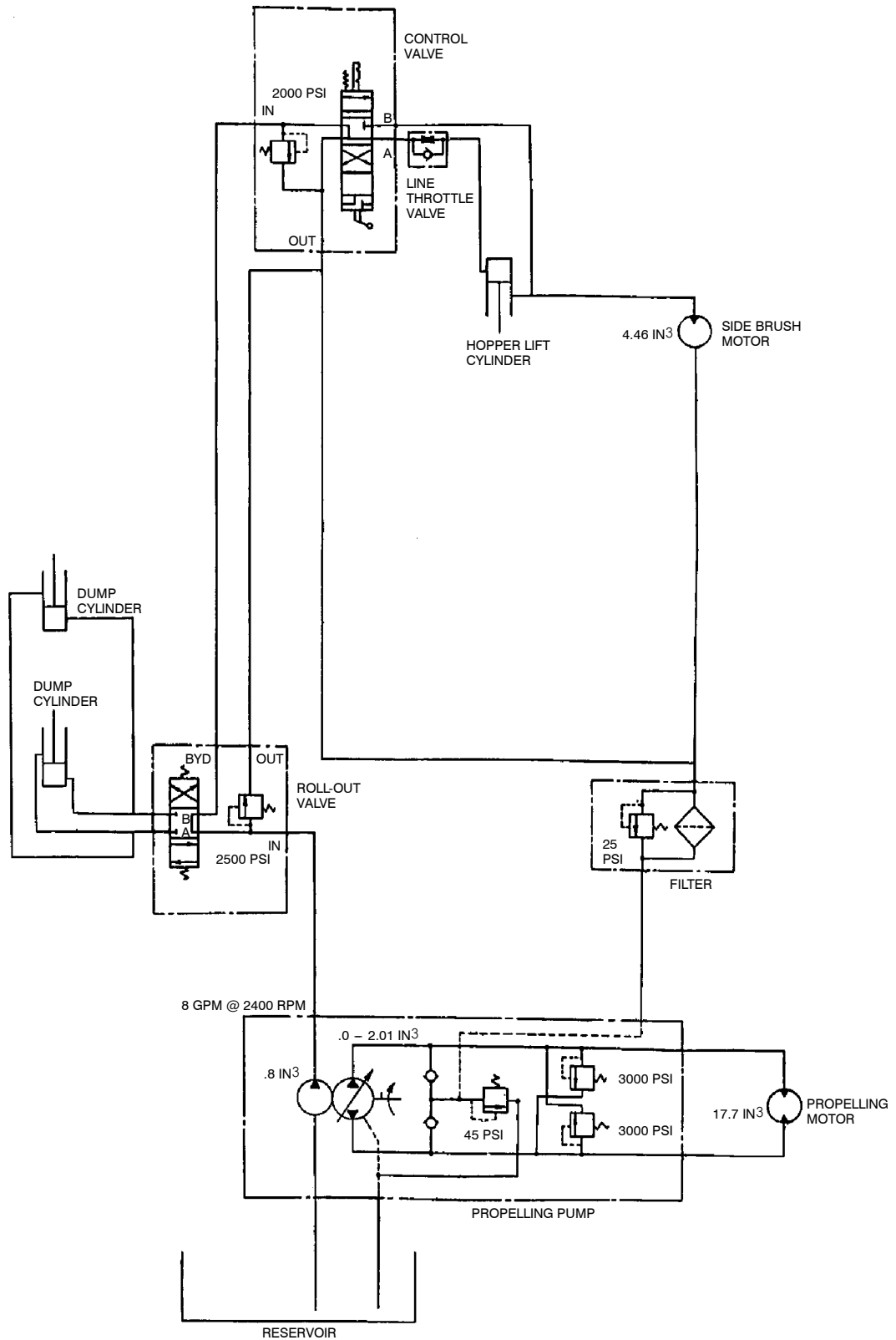

HYDRAULIC SCHEMATIC, MULTI-LEVEL DUMP
 (For machines below serial number 005106)

05546

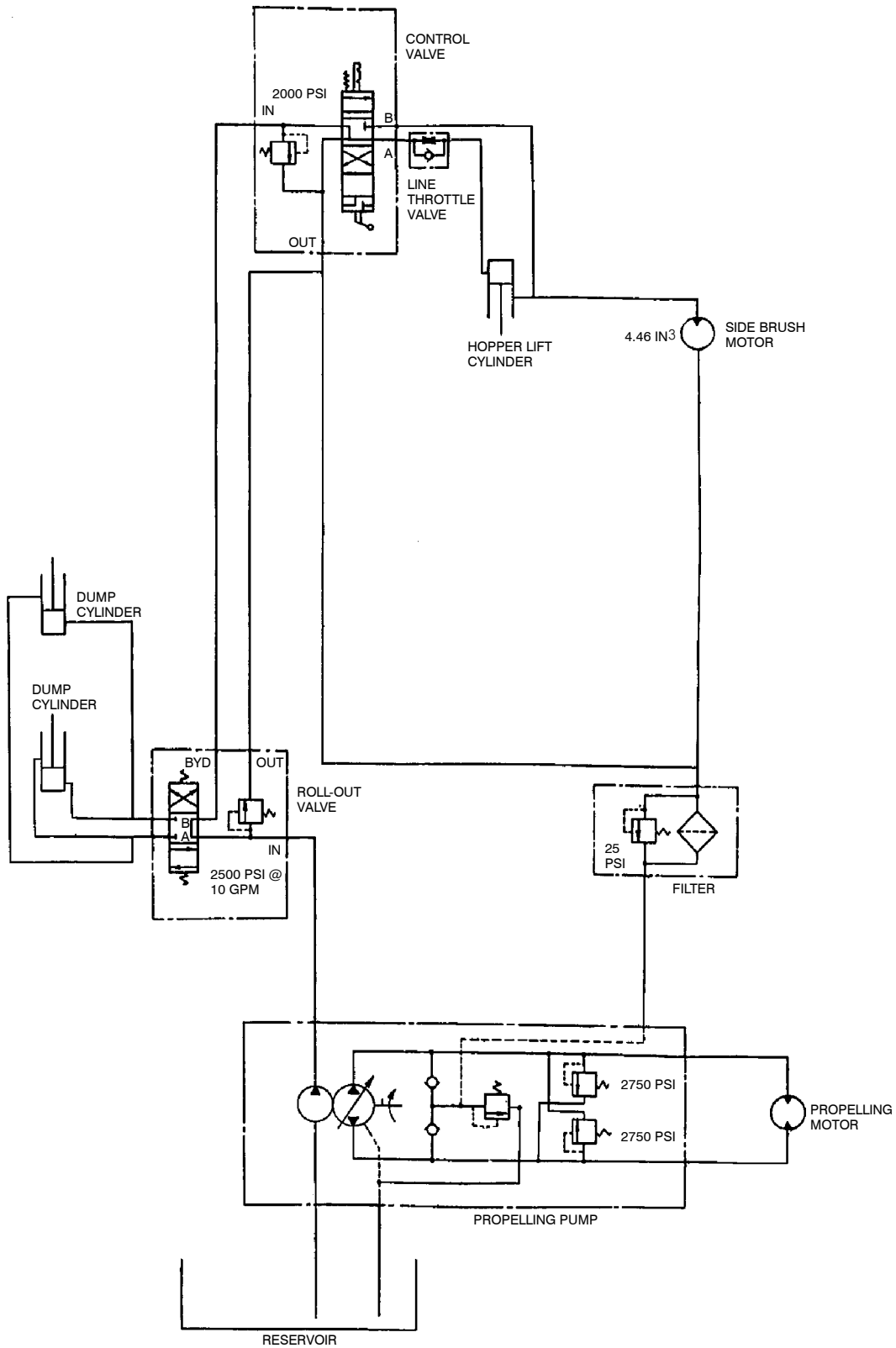

**HYDRAULIC SCHEMATIC, MULTI-LEVEL DUMP
(For machines serial number 005106 and above)**

07400

ELECTRICAL SYSTEM

BATTERIES

The batteries provide all of the energy used by the machine. The standard batteries are rated at 600 A/h at a 6-hour rate. The maximum battery size is 15.63 in (395 mm) in width, 19.25 in (490 mm) in length, and 23.42 in (595 mm) in height. They require regular maintenance to keep them operating their best.

When installing new or replacement batteries, lift the left-hand battery using the end holes and the right-hand battery with the side holes.

Do not allow batteries to remain in discharged condition for any length of time.

Do not operate machine if batteries are in poor condition or have a charge level below 25%, specific gravity below 1.162.

Periodically clean the top surface and check for loose connections. Use a strong solution of baking soda and water. Brush the solution sparingly over the battery top. Do not allow any baking soda solution to enter the battery. Keep the tops of the batteries clean and dry.

Keep all metallic objects off the top of the batteries, as they may cause a short circuit. Replace worn or damaged wires.

Check the electrolyte level in each battery cell before and after charging the batteries and after every 50 hours of operation. Never add acid to batteries, only distilled water. Do not overfill. Keep vent plugs firmly in place at all times, except when adding water or taking hydrometer readings.

FOR SAFETY: When Servicing Machine, Avoid Contact With Battery Acid.

Use a hydrometer to check the electrolyte specific gravity.

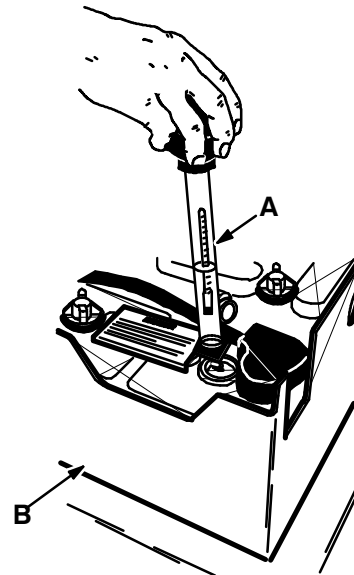

CHECKING BATTERY SPECIFIC GRAVITY

03704

- A. Hydrometer**
- B. Battery**

If one or more battery cells tests lower than the other battery cells, (0.050 or more) the cell is damaged, shorted, or is about to fail.

NOTE: Do not take readings immediately after adding water – if the water and acid are not thoroughly mixed, the readings may not be accurate. Check the hydrometer readings against the following chart:

SPECIFIC GRAVITY at 80° F (27° C)	BATTERY CONDITION
1.315	100% charged
1.264	75% charged
1.213	50% charged
1.162	25% charged
1.110	Discharged

NOTE: If the readings are taken when the battery electrolyte is any temperature other than 80° F (27° C), the reading must be temperature corrected.

MAINTENANCE

To determine the corrected specific gravity reading when the temperature of the battery electrolyte is other than 80° F (27° C):

Add to the specific gravity reading 0.004, 4 points, for each 10° F (6° C) above 80° F (27° C).

Subtract from the specific gravity reading 0.004, 4 points, for each 10° F (6° C) below 80° F (27° C).

BATTERY CHARGING

The machine batteries are specially made for this machine application. They are unique in that they hold their power for long periods of time, but they can only be recharged a certain number of times. To get the most life from the batteries, charge them when their charge level is below 25%.

Eight to twelve hours is generally enough time to charge a discharged set of batteries. If the batteries are not fully discharged, charge for a period of time that is proportionally less than what is required for a fully discharged set of batteries.

Do not expose the battery charger to water. Do not touch uninsulated battery terminals or unnecessarily expose any portion of your body to the batteries when making electrical connections.

TO CHARGE BATTERIES

1. Stop the machine on a flat, dry surface next to the charger and set the machine parking brake. Turn off the machine.

FOR SAFETY: Before Leaving Or Servicing Machine; Stop On Level Surface, Set Parking Brake, And Turn Off Machine And Remove Key.

2. Remove the seat cushion from the operator seat and tilt it forward. Open the battery cover.

⚠ WARNING: Batteries Emit Hydrogen Gas. Explosion Or Fire Can Result. Keep Sparks And Open Flame Away. Keep Covers Open When Charging.

3. Check the electrolyte level in the batteries. Before charging, add just enough distilled water to cover the plates. Then, after charging is completed, add enough water to bring the electrolyte up to 0.25 in (5 mm) below the bottom of the filling hole. If the water level is topped off before charging, normal expansion of the electrolyte may cause an overflow, resulting in loss of acid balance and acid damage to the machine area around the batteries.
4. Replace battery caps and leave them in place while charging.
5. Disconnect the motor connector from the battery connector.

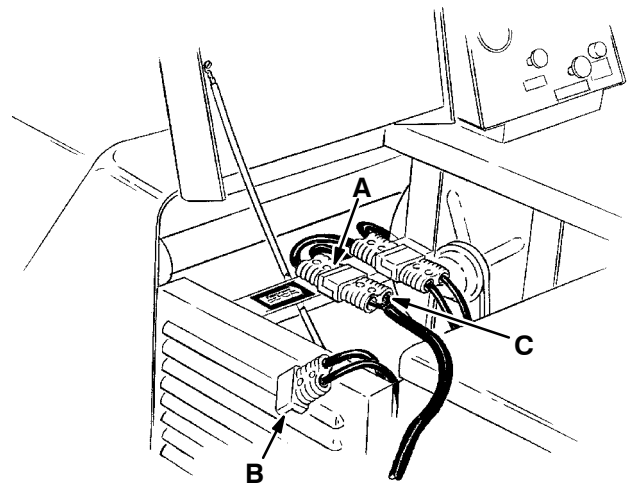

BATTERY CHARGING

05180

- A. Battery Connector**
- B. Motor Connector**
- C. Charger Connector**

6. Plug the charger connector into the battery connector. Both batteries will be charged at the same time.

7. Set the charger timer for 6 to 8 hours for fully discharged batteries.

On every 5th charge, set the charger timer for the full 12 hours. This will equalize all the cells and bring the batteries to peak capacity.

The recommended chargers automatically taper the charge rate as the batteries are charged. There is little chance of overcharging. Set the timer for the full charge time if there is doubt of the charge left in the batteries.

8. Unplug the charger connector from the battery connector.
9. Reconnect the motor connector to the battery connector.
10. Check the electrolyte level of the batteries; it should be 0.25 in (5 mm) below the bottom of the filling hole.
11. Close the battery cover. Lower the operator seat and replace the seat cushion.

ELECTRIC MOTORS

There are three electric motors on the machine. The propelling motor, scrub attachment vacuum fan motor, and the scrub attachment scrub brush motor. The electric motors are repairable.

Blow out the dust and inspect the motor brushes in the motors after every 250 hours of operation.

If the brushes are broken, cracked, chipped, or have been worn to less than 0.75 in (20 mm) in length on the short side on the propelling motor and scrub attachment scrub motor, or 0.38 in (10 mm) in length on the short side on the scrub attachment vacuum fan motor, replace them. Remember to always replace brushes in sets.

If the commutator is worn or rough, the motor armature should be removed and serviced.

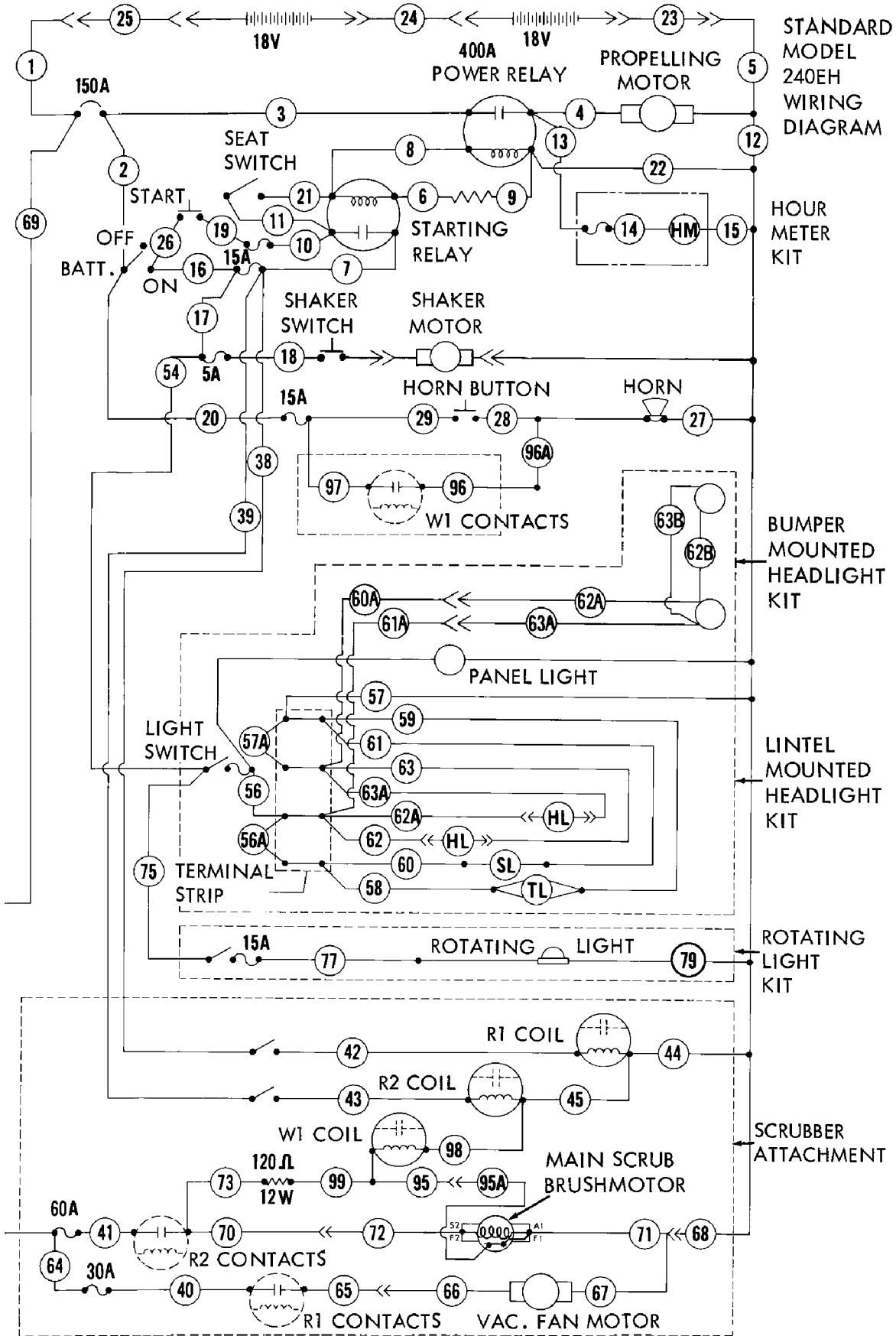

ELECTRIC SCHEMATIC

05805

BELTS AND CHAINS

PUMP BELT

The pump belt transfers power from the electric motor to the hydraulic pump. Check the belt condition after every 50 hours of operation. The pump belt tension is automatically adjusted by a spring in the pump mount. No adjustment is necessary.

TO REPLACE PUMP BELT

1. Turn off the machine and set the machine parking brake.

FOR SAFETY: Before Leaving Or Servicing Machine; Stop On Level Surface, Set Parking Brake, And Turn Off Machine And Remove Key.

2. Open the battery cover.
3. Remove the cotter pin from the slotted nut on the end of the yoke.

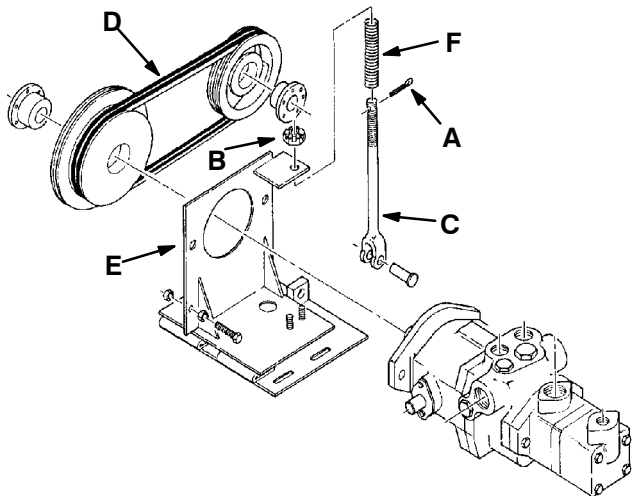

PUMP BELT MOUNTING

01710

- A. Cotter Pin**
- B. Slotted Nut**
- C. Yoke**
- D. Belt**
- E. Pump Mounting Bracket**
- F. Spring**

4. Turn down the slotted nut until the pump belt is loose enough to remove.
5. Install the new pump belt. Adjust the pump and pump mounting bracket position so that the spring length is 6.0 ± 0.1 in (150 ± 3 mm) with the slotted nut backed off.

6. Back off the slotted nut to the top of yoke until the cotter pin hole lines up with a slot on the nut.
7. Install the cotter pin.

COUNTERSHAFT BELT

The countershaft belt transfers power from the electric motor to the countershaft. Check the belt condition and tension after every 50 hours of operation. The belt is properly tensioned when it deflects 0.38 in (10 mm) from a force of 6 lb (2.72 kg) at midpoint, or Burrough's Tensionmeter reading 55 to 60 lb (25 to 27 kg). Adjust idler sheave position to obtain correct deflect.

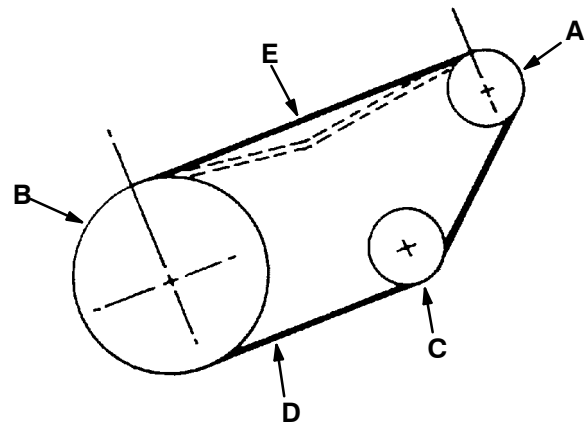

COUNTERSHAFT BELT

05541

- A. Motor Sheave**
- B. Countershaft Sheave**
- C. Idler Sheave**
- D. Countershaft Belt**
- E. Midpoint**

MAINTENANCE

MAIN BRUSH BELT

The main brush belt transfers power from the countershaft to the main brush drive. Check the belt condition and tension every 50 hours of operation. For proper belt tension, the length of the belt idler spring should be 9.88 in (250 mm) when the brush is in the "RESTRICTED DOWN" position.

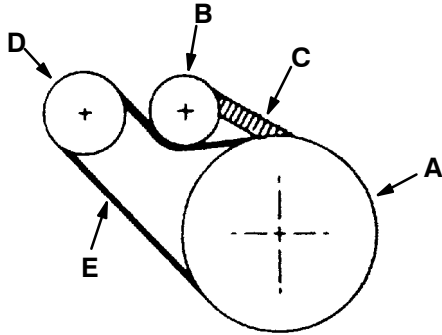

MAIN BRUSH BELT

05376

- A. Brush Sheave
- B. Idler Sheave
- C. Spring
- D. Countershaft Sheave
- E. Brush Belt

STATIC DRAG CHAIN

A static drag chain is provided to prevent the buildup of static electricity in the machine. The chain is attached to the machine by a rear brush skirt retaining screw.

The chain should make contact with the floor at all times.

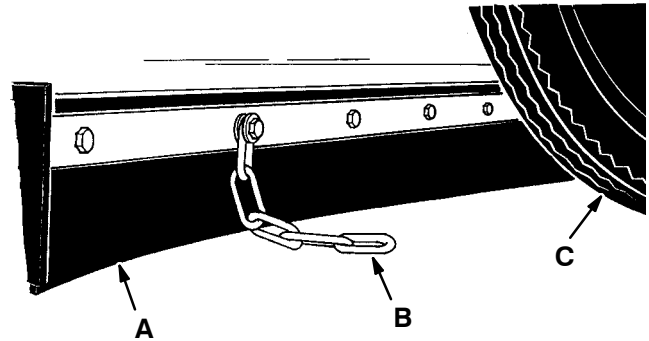

STATIC DRAG CHAIN

00588

- A. Rear Dust Skirt
- B. Static Drag Chain
- C. Rear Tire

VACUUM FAN BELT

The vacuum fan belt transfers power from the electric motor to the vacuum fan. Check the belt condition every 50 hours of operation. The vacuum fan belt tension is maintained by a spring on the vacuum fan mounting. No adjustment is necessary.

SCRUB ATTACHMENT VACUUM FAN BELT

The scrub attachment vacuum fan belt transfers power from the vacuum fan electric motor to the vacuum fan assembly on the EE model machine. Check the belt condition every 50 hours of operation. The vacuum fan belt tension is maintained by a spring mounted idler. No adjustment is necessary.

DEBRIS HOPPER

HOPPER DUST FILTER

The dust filter filters the air which is drawn up from the main brush compartment through the hopper. The dust filter is equipped with a shaker motor to remove the accumulated loose dust particles. The dust filter shaker motor is operated by the filter shaker switch. Shake the dust filter before dumping the hopper and at the end of every work shift. Inspect and clean or replace the dust filter after every 100 hours of operation.

To clean the dust filter, use one of the following methods:

- * **TAPPING** – Tap the filter gently on a flat surface with the dirty side down. Do not damage the edges of the filter element or the filter will not seat properly in the filter frame.
- * **AIR** – Blow compressed air, 35 psi (240 kPa) maximum, through the dust filter opposite the direction of the arrows. This may be done with the dust filter in the machine. Always wear eye protection when using compressed air.
- * **WATER** – Soak the dust filter in a water and mild detergent solution. Rinse the dust filter until it is clean. The maximum water pressure allowable is 40 psi (275 kPa). Air dry the wet dust filter; do not use compressed air.

NOTE: Be sure the dust filter is dry before reinstalling it in the machine.

TO REMOVE HOPPER DUST FILTER

1. Turn off the machine and set the machine parking brake.

FOR SAFETY: Before Leaving Or Servicing Machine; Stop On Level Surface, Set Parking Brake, And Turn Off Machine And Remove Key.

2. Release the two hopper cover latches and remove the hopper cover.
3. Disconnect the shaker motor wire connectors.

4. Remove the four shaker frame nuts and shaker frame from the filter frame.

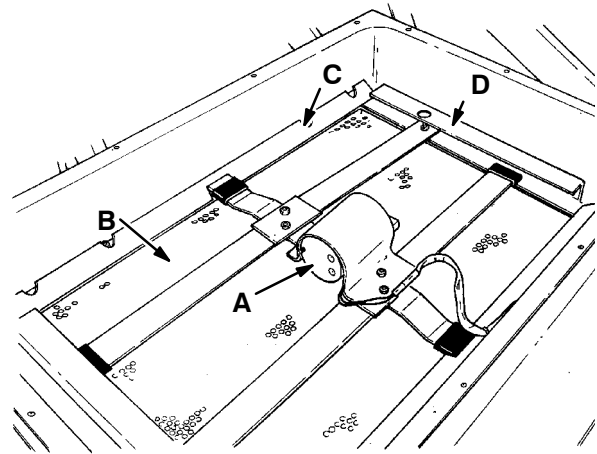

02463

DUST FILTER SHAKER ASSEMBLY

- A. Filter Shaker Motor**
- B. Dust Filter**
- C. Frame Nut**
- D. Shaker Frame**

5. Lift the dust filter element out of the dust filter frame.
6. Clean or discard the dust filter as required.

TO INSTALL HOPPER DUST FILTER

1. Place the cleaned or new dust filter in the hopper dust filter frame with the arrows pointing up.

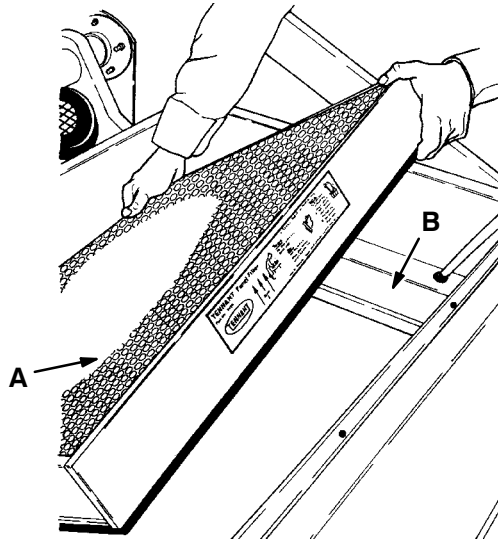

INSTALLING DUST FILTER

02464

- A. Dust Filter**
- B. Dust Filter Frame**

2. Position the shaker frame on top of the filter frame.
3. Replace and tighten the shaker frame nuts.
4. Position and secure the hopper cover on the hopper with the cover latches.

HOPPER FUSIBLE LINK

The hopper fusible link is a device which, in case of fire in the hopper, allows the hopper fire door to close, cutting off air to the fire.

The fusible link is positioned between the hopper fire door and the hopper cover. It is mounted inside the hopper cover. Check the fusible link after every 100 hours of operation.

If loss of dust control is noticed, check the fusible link for breakage or failure due to heat.

TO REPLACE HOPPER FUSIBLE LINK

1. Turn off the machine and set the machine parking brake.

FOR SAFETY: Before Leaving Or Servicing Machine; Stop On Level Surface, Set Parking Brake, And Turn Off Machine And Remove Key.

2. Open the hopper cover and turn the cover upside down.
3. Remove the existing pieces of fusible link and their retaining hardware.
4. Slide a new fusible link over the link mounting pins and mount with the retaining hardware.
5. Open the fire door.
6. Place the fire door hook over the middle of the fusible link.
7. Put the hopper cover back on the hopper.

DEBRIS HOPPER

The debris hopper collects the debris swept up by the machine. The low dump model hopper has one adjustment, floor clearance. The multi-level dump model hopper has five adjustments; lift linkage, lift cylinder, floor clearance, dump cylinders, and dump door latches. All of the adjustments have been made at the factory and require no regular maintenance. If the hopper components are repaired or replaced, the hopper must be readjusted for best performance.

The hopper adjustments must be made in the order given. Make all adjustments with the machine off and parking brake set. If the adjustments are made with the hopper raised, be sure to engage the hopper support bar.

TO ADJUST LOW DUMP MODEL HOPPER

NOTE: Empty the debris hopper before making adjustments.

1. FLOOR CLEARANCE ADJUSTMENT

- A. Turn off the machine and set the machine parking brake.

FOR SAFETY: Before Leaving Or Servicing Machine; Stop On Level Surface, Set Parking Brake, And Turn Off Machine And Remove Key.

- B. Slide a 0.75 to 0.88 in (20 to 25 mm) thick block under each of the rear metal corners of the hopper.
- C. Check and adjust the cams on the lift arms so the hopper brackets rest on the cams.

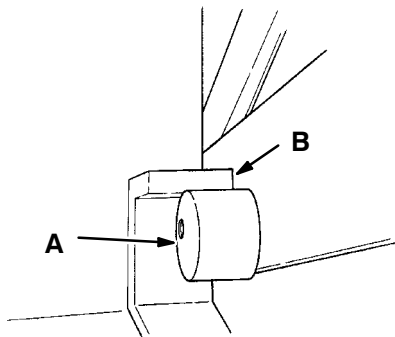

HOPPER CAM

02479

- A. Cam
- B. Hopper Bracket

TO ADJUST MULTI-LEVEL DUMP MODEL HOPPER

NOTE: Empty the debris hopper before making adjustments.

1. HOPPER LIFT LINKAGE ADJUSTMENT.

- A. Stand clear and cycle the hopper up and down. Watch for signs of binding, sloppiness, or misalignment of the lift arm linkage. Reshim to remove binding, sloppiness, or misalignment of the linkage as necessary.



WARNING: Lift Arm Pinch Point. Stay Clear Of Hopper Lift Arms.

- B. Turn off the machine and set the machine parking brake.

FOR SAFETY: Before Leaving Or Servicing Machine; Stop On Level Surface, Set Parking Brake, And Turn Off Machine And Remove Key.

- C. Measure the distance from the center of each of the torque shafts to the floor with the hopper is lowered for operating.

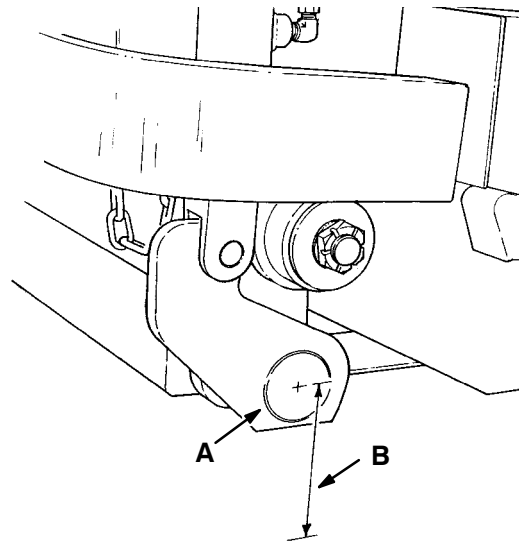

TORQUE SHAFT HEIGHT

00593

- A. Torque Shaft
- B. Measured Distance

The distance measured should be 6.25 ± 0.13 in (160 ± 3 mm). To adjust the height, remove one or both of the splined lift arm cams and rotate it or them until the proper dimension is achieved. The cams must rest on the sloping edge of the lintel.

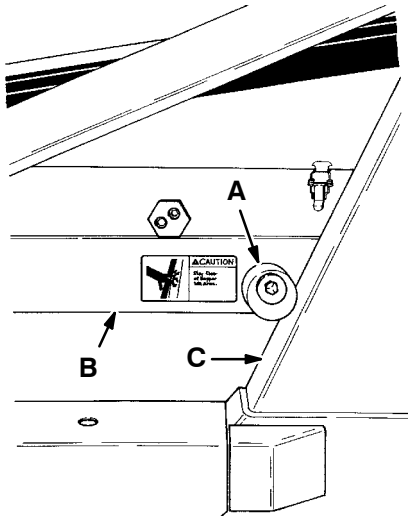

LIFT ARM CAM

02451

- A. Lift Arm Cam
- B. Lift Arm
- C. Lintel

D. Tighten the lift arm cam bolt(s).

2. HOPPER LIFT CYLINDER ADJUSTMENT

A. Loosen the clevis jam nut on the cylinder rod.

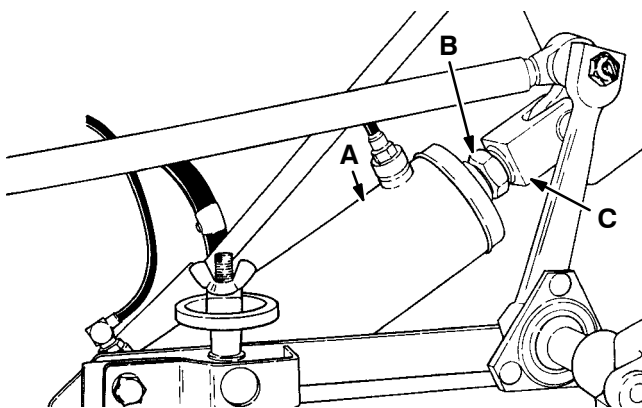

HOPPER LIFT CYLINDER

00563

- A. Hopper Lift Cylinder
- B. Jam Nut
- C. Cylinder Clevis

B. Adjust the cylinder clevis so the cylinder is fully retracted by inserting a pin through the cylinder rod and rotating it.

C. Tighten the clevis jam nut against the clevis.

3. HOPPER FLOOR CLEARANCE ADJUSTMENT

A. Remove the clevis pins connecting the clevis of the hopper dump cylinders to the torque arms.

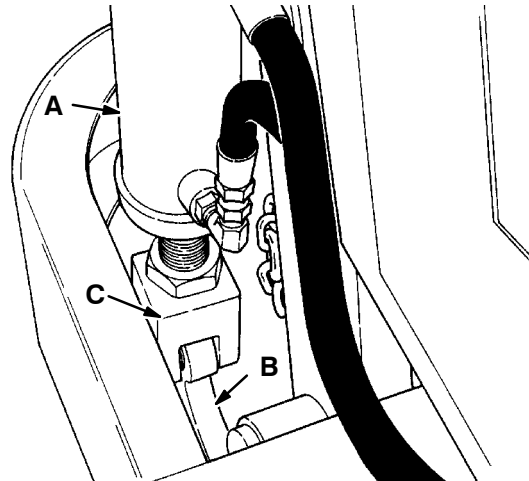

HOPPER DUMP CYLINDER

00595

- A. Hopper Dump Cylinder
- B. Torque Arm
- C. Clevis

B. Disconnect the dump cylinder clevis ends from the torque arms.

C. Place a 3.00 ± 0.13 in (75 ± 5 mm) block under each of the rear sides of the hopper.

- D. Check and adjust, if necessary, the hexagon hopper cams on each side of the hopper so they contact the top surface of the hopper lift arms.

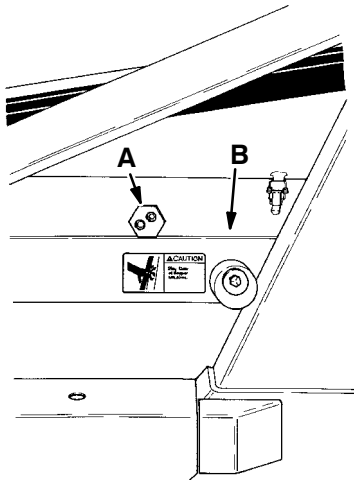

HEXAGON HOPPER CAM

02451

- A. Hexagon Hopper Cam
- B. Hopper Lift Arm

- E. Tighten the hexagon hopper cam bolts.

- F. Reconnect the dump cylinder clevises to the torque arms with the clevis pins removed earlier.

4. DUMP CYLINDERS ADJUSTMENT

- A. Start the machine and completely retract the dump cylinders.

- B. Turn the machine off and set the machine parking brake.

FOR SAFETY: Before Leaving Or Servicing Machine; Stop On Level Surface, Set Parking Brake, And Turn Off Machine And Remove Key.

- C. Loosen the cylinder clevis jam nuts.

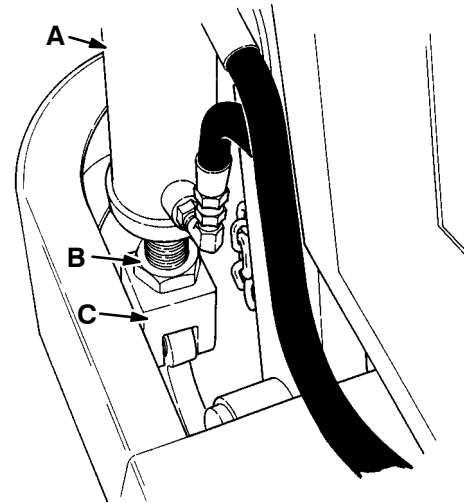

HOPPER DUMP CYLINDER

00595

- A. Hopper Dump Cylinder
- B. Jam Nut
- C. Cylinder Clevis

- D. Remove clevis pin retaining rings and clevis pins.

- E. Adjust the cylinder clevis so the dump cylinder clevis and torque arm, and the clevis pin holes align and allow the clevis pin to pass freely through them.

- F. Tighten the clevis jam nuts.

- G. Secure the clevis pins in place with their retaining rings.

5. DUMP DOOR LATCHES ADJUSTMENT

- A. Start the machine and dump the hopper.
- B. Return the hopper to the operating position. Turn off the machine.
- C. Check the hopper door latches to be sure they are engaged and the hopper door is closed tightly.

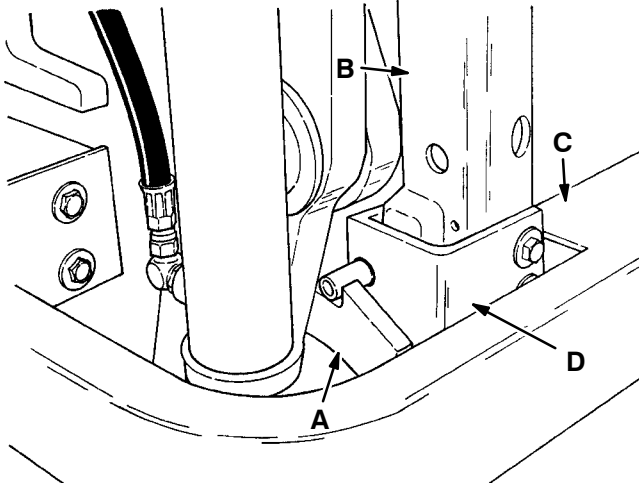

HOPPER DUMP DOOR LATCH

00597

- A. Hopper Dump Door Latch
- B. Hopper Door
- C. Bumper
- D. Latching Bracket

- D. Adjust latching action by adjusting latch stop bolt. Do not position stop bolt too high or the door will close too tightly and damage the seal and latches.

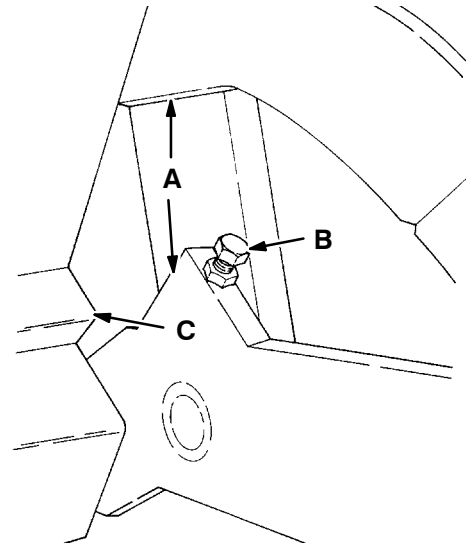

LATCH STOP BOLT

02484

- A. Lift Arm
- B. Stop Bolt
- C. Hopper

- E. Shim the hopper door latching brackets to adjust the hopper door latch engagement and hopper door seal compression. Do not compress the seal too much or the door will close too tightly and damage the seal and latches.

- F. Start the machine.

- G. Dump the hopper and observe the unlatching of the hopper door. The latches should release at the same time. Adjust the latch chain eyebolts if necessary.

BRUSHES

MAIN BRUSH

The main brush is tubular and spans the width of the machine, sweeping debris into the debris hopper. It should be inspected daily for wear or damage. Remove any string or wire found tangled on the main brush, main brush drive hub, or main brush idler hub.

Rotate the main brush end-for-end after every 50 hours of operation for maximum brush life and best sweeping performance.

The main brush pattern should be checked daily. It should be 2 in (50 mm) wide in the “RESTRICTED DOWN” position. Main brush pattern adjustments are made by turning the main brush down pressure knob located left of the steering column.

The main brush should be replaced when the remaining bristles measure 1 in (25 mm) in length.

TO REPLACE MAIN BRUSH

1. Turn off the machine and set the machine parking brake.

FOR SAFETY: Before Leaving Or Servicing Machine; Stop On Level Surface, Set Parking Brake, And Turn Off Machine And Remove Key.

2. Place the main brush position lever in the “RESTRICTED DOWN” position.
3. Open the right side main brush door.
4. Remove the brush idler arm retaining bolt from the arm hub.
5. Pull the brush idler arm off the arm hub.
6. Grasp the main brush; pull it off the brush drive plug and out of the main brush compartment.

7. Place the new or rotated end-for-end main brush on the floor next to the access door.
8. Slide the main brush onto the drive plug. Rotate the brush until it engages the drive plug and push it all of the way onto the plug.
9. Slide the main brush idler plug onto the main brush.
10. Slide the brush idler arm onto the arm hub.
11. Thread the brush idler arm retaining bolt through the idler arm and into the arm hub. Tighten the retaining bolt.
12. Close the right side main brush door.
13. Check and adjust the main brush pattern as described in *TO CHECK AND ADJUST MAIN BRUSH PATTERN*.

TO CHECK AND ADJUST MAIN BRUSH PATTERN

1. Apply chalk, or some other material that will not blow away easily, to a smooth, level floor.
2. With the side brush and main brush raised, position the main brush over the chalked area.
3. Place the main brush position lever in the “RESTRICTED DOWN” position for 15 to 20 seconds while keeping a foot on the brakes to keep the machine from moving.
4. Place the main brush position lever in the “RAISED POSITION”.

NOTE: If chalk or other material is not available, allow the brushes to spin on the floor for two minutes. A polish mark will remain on the floor.

5. Drive the machine off the test area.

MAINTENANCE

6. Observe the width of the brush pattern. The proper brush pattern width is 2 in (50 mm).

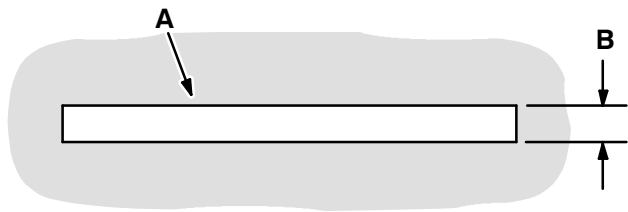

NORMAL MAIN BRUSH PATTERN

- A. Main Brush Pattern**
B. Pattern Width

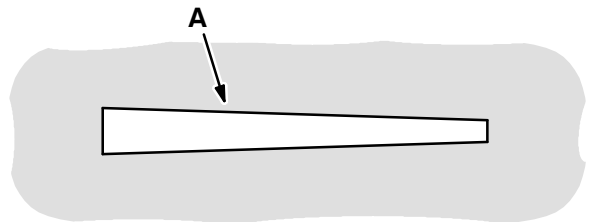

TAPERED MAIN BRUSH PATTERN

- A. Main Brush Pattern**

If the main brush pattern is tapered, more than 0.5 in (15 mm) on one end than the other, on a flat, level surface, loosen the screws in the slotted holes of the countershaft bearing mounting bracket at the idler end of the main brush. Move the counter shaft assembly up to decrease the brush pattern width on the idler side of the main brush, and down to increase the brush pattern width. Tighten the mounting screws of the countershaft bearing mounting bracket. Check the main brush pattern and readjust as necessary. Then adjust the width of the main brush pattern.

To adjust the brush pattern's overall width, use the main brush down pressure knob. To increase the brush pattern width, turn the knob counter-clockwise. To decrease the brush pattern width, turn the knob clockwise.

SIDE BRUSH

The side brush sweeps debris from curbs or gutters into the path of the main brush. It should be inspected daily for wear or damage. Remove any string or wire found tangled on the side brush or side brush drive hub.

The side brush pattern should be checked daily. Between one-half and two-thirds of the side brush bristles should contact the floor when the brush is in motion. The side brush should be replaced when the remaining brush bristle measures 2.5 in (65 mm) in length.

The side brush pattern adjustment on low dump model machines is made by loosening the two nuts on the side brush arm, repositioning the side brush assembly, and retightening the nuts.

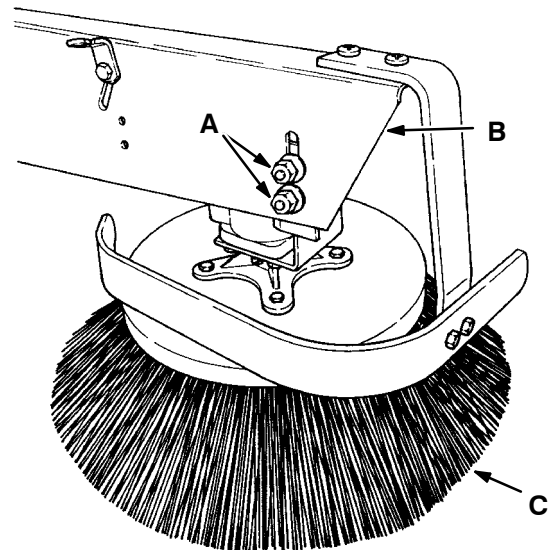

LOW DUMP MODEL SIDE BRUSH

- A. Nut**
B. Side Brush Arm
C. Side Brush

The side brush pattern adjustment on multi-level dump model machines is made by loosening the two screws on the side brush arm, repositioning the side brush assembly, and retightening the screws.

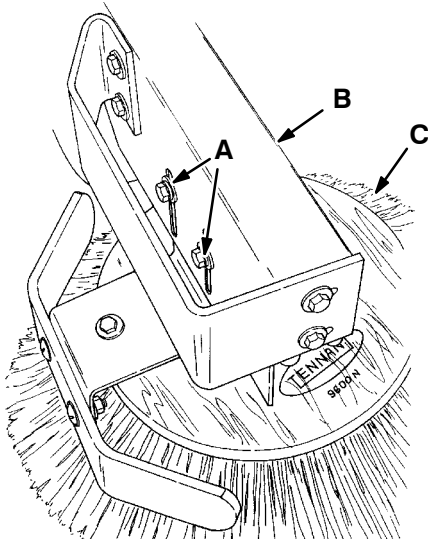

MULTI-LEVEL DUMP MODEL SIDE BRUSH

00603

- A. Screw**
- B. Side Brush Arm**
- C. Side Brush**

TO REPLACE SIDE BRUSH

1. Empty the debris hopper.
2. Raise the hopper, engage the hopper support bar, and lower the hopper onto the support bar.

! WARNING: Raised Hopper May Fall. Engage Hopper Support Bar.

3. Turn off the machine and set the machine parking brake.

FOR SAFETY: Before Leaving Or Servicing Machine; Stop On Level Surface, Set Parking Brake, And Turn Off Machine And Remove Key.

4. Raise the side brush.

5. Remove the screw and nut holding the side brush hub on the side brush drive shaft.

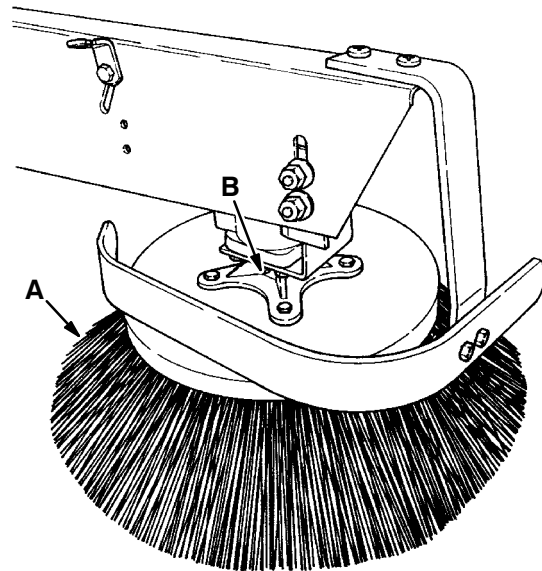

SIDE BRUSH

02485

- A. Side Brush**
- B. Retaining Pin**

6. Slide the side brush off the side brush drive shaft.
7. Slide the new side brush onto the side brush drive shaft.
8. Insert the screw through the side brush hub and shaft and tighten the nut.
9. Disengage the hopper support bar and lower the hopper.

SKIRTS AND SEALS

HOPPER LIP SKIRTS

The hopper lip skirts are located on the bottom rear of the hopper. They float over debris and help deflect that debris into the hopper. The hopper lip skirts are made up of five bottom lip segments and two additional side lip segments on multi-level dump model machines.

The hopper lip skirts should be inspected for wear or damage daily.

TO REPLACE HOPPER LIP SKIRTS

1. Empty the machine debris hopper.
2. Engage the machine parking brake.
3. Raise the hopper, engage the hopper support bar, and lower the hopper onto the hopper support bar.



WARNING: Raised Hopper May Fall. Engage Hopper Support Bar.

4. Turn off the machine.

FOR SAFETY: Before Leaving Or Servicing Machine; Stop On Level Surface, Set Parking Brake, And Turn Off Machine And Remove Key.

5. Remove the hopper lip retaining strip mounting screws.

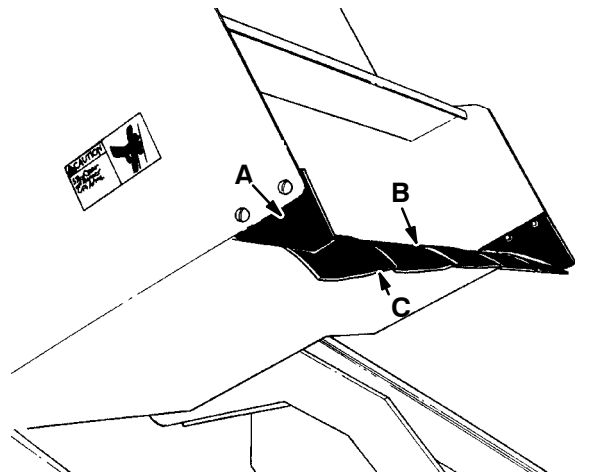

HOPPER LIP SKIRTS

00604

- A. Hopper Lip Side Skirt
- B. Retaining Strip
- C. Hopper Lip Skirts

6. Remove the hopper lip retaining strip and worn or damaged hopper lip.
7. Thread the retaining strip mounting screws through the retaining strip, the hopper lip segment, and into the hopper.
8. Tighten the mounting screws.
9. Start the machine.
10. Raise the hopper, lower the hopper support bar, and lower the hopper.
11. Turn off the machine.

BRUSH DOOR AND SIDE SKIRTS

The brush door skirt is located on the bottom of the right main brush door. The side skirt is mounted to the machine frame on the left side of the brush compartment. They seal the main brush compartment. They should clear the floor up to a maximum of 0.13 in (3 mm).

The skirts should be inspected for wear or damage and adjustment daily.

TO REPLACE AND ADJUST BRUSH DOOR SKIRT

1. Stop the machine on a smooth, level surface.
2. Turn off the machine and engage the machine parking brake.

FOR SAFETY: Before Leaving Or Servicing Machine; Stop On Level Surface, Set Parking Brake, And Turn Off Machine And Remove Key.

3. Open the right main brush door.
4. Remove the brush door skirt retaining screws from the right brush door.
5. Remove the skirt retaining strip and the door skirt.
6. Position the new door skirt and skirt retaining strip on the brush door.

7. Thread the skirt retaining screws through the brush door, the door skirt, and into the skirt retaining strip.

NOTE: The brush door skirt has slotted holes to allow for a ground clearance adjustment. The door must be closed for proper adjustment.

8. Slide the brush door skirt up or down so that the skirt clears the floor by 0.13 in (3 mm).
9. Tighten the skirt retaining screws.
10. Close the right brush door.

TO REPLACE AND ADJUST SIDE SKIRT

1. Open the left main brush door.
2. Remove the skirt retaining screws from the machine frame.
3. Remove the skirt retaining strip and the side skirt.
4. Position the new skirt and skirt retaining strip on the machine frame.
5. Thread the skirt retaining screws through the machine frame, the side skirt, and into the skirt retaining strip.
6. Slide the side skirt up or down so that the skirt clears the floor by 0.13 in (3 mm).
7. Tighten the skirt retaining screws.
8. Close the left main brush door.

REAR SKIRT

The rear skirt is located on the bottom rear of the main brush compartment. It seals the main brush compartment. It should clear the floor by 0.13 in (3 mm).

The seal should be inspected for wear or damage and adjustment daily.

TO REPLACE AND ADJUST THE REAR SKIRT

1. Stop the machine on a smooth, level surface.

2. Turn off the machine and engage the machine parking brake.

FOR SAFETY: Before Leaving Or Servicing Machine; Stop On Level Surface, Set Parking Brake, And Turn Off Machine And Remove Key.

3. Open the main brush doors.
4. Remove the main brush as described in *TO REPLACE MAIN BRUSH*.
5. Remove the rear skirt retaining strip, rear skirt, and the static drag chain.
6. Thread the rear skirt retaining strip mounting screws through the retaining strip, the new rear floor skirt, and into the machine frame. Be sure to mount the static drag chain with one of the mounting screws.
7. Slide the rear floor skirt up or down so that the skirt clears the floor 0.13 in (3 mm).
8. Tighten the rear floor skirt mounting screws.
9. Reinstall the main brush.
10. Close the main brush doors.

MAIN BRUSH DOOR SEALS

The main brush door seals are located on corresponding portions of the main frame. They seal the main brush compartment.

The seals should be inspected for wear or damage after every 100 hours of operation.

HOPPER SEALS

The hopper seals are located on the top and side portions of the machine frame which contact the hopper. They seal the main brush compartment.

The seals should be inspected for wear or damage after every 100 hours of operation.

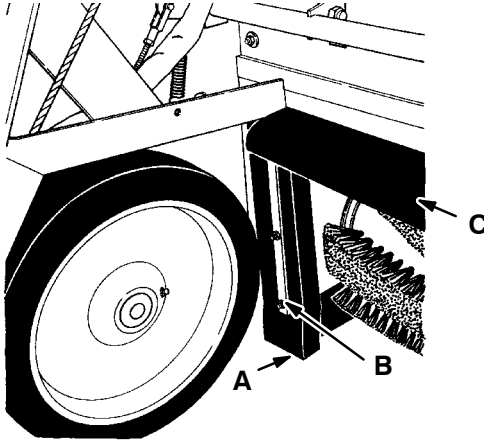

HOPPER SEALS

02457

- A. Side Seal
- B. Seal Retaining Strip
- C. Top Seal

HOPPER INSPECTION DOOR SEAL

The hopper inspection door seal is located on the hopper inspection door on low dump model machines. It seals the front of the debris compartment.

The seal should be checked for wear or damage after every 100 hours of operation.

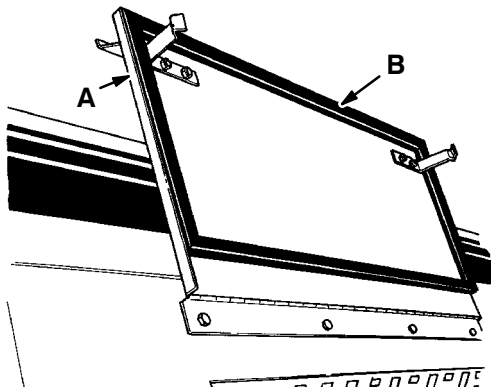

HOPPER INSPECTION DOOR SEAL

02480

- A. Hopper Inspection Door
- B. Door Seal

HOPPER DOOR SEALS

The hopper door seals are located around the hopper door opening on multi-level dump model machines. They seal the hopper door.

The seals should be checked for wear or damage after every 100 hours of operation.

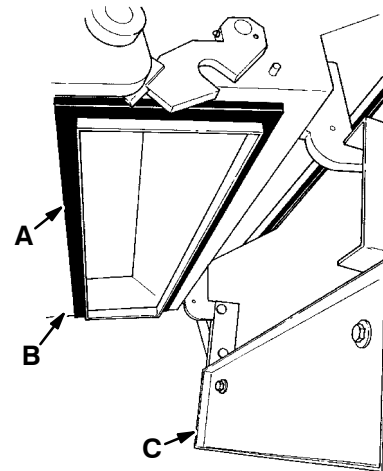

HOPPER DOOR SEALS

02481

- A. Seal
- B. Hopper
- C. Hopper Door

HOPPER COVER SEAL

The hopper cover seal is located on the top edges of the hopper. It seals the hopper filter compartment.

The seal should be checked for wear or damage after every 100 hours of operation.

HOPPER VACUUM FAN SEAL

The hopper vacuum fan seal is mounted to the lintel on multi-level dump model machines. It seals the hopper filter compartment to the vacuum fan intake bracket.

The seal should be checked for wear or damage after every 100 hours of operation. Check to make sure that the seal is making good contact with the hopper. The seal should be compressed 0.12 in (3 mm) by the contact.

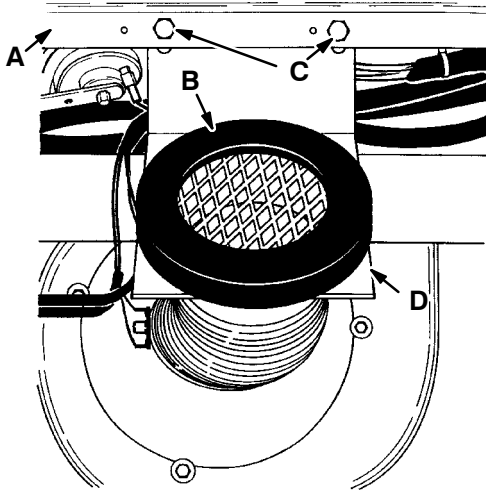

02465

HOPPER VACUUM FAN SEAL

- A. Lintel**
- B. Seal**
- C. Mounting Screws**
- D. Bracket**

To adjust seal contact, loosen the vacuum fan intake bracket mounting screws. Pivot the bracket into the correct position and retighten the screws.

BRAKES AND TIRES

SERVICE BRAKES

The mechanical service brakes are located on the front wheels. They are operated by the foot brake pedal and connecting linkages.

The brake pedal should not travel more than 1 in (25 mm) to fully engage the brakes. Blow the accumulated dirt from between the brake shoes and the hub with compressed air through the slots on the side wheel pockets. Check the brake adjustment after every 200 hours of operation.

TO ADJUST BRAKE LINKAGE

1. Empty the debris hopper.
2. Raise the hopper, engage the hopper support bar, and lower the hopper onto the support bar.



WARNING: Raised Hopper May Fall. Engage Hopper Support Bar.

3. Turn off the machine and block the machine tires.

FOR SAFETY: Before Leaving Or Servicing Machine; Stop On Level Surface, And Turn Off Machine And Remove Key.

4. Remove the clevis pins from the left and right side brake clevises.

5. Thread the clevis out to decrease brake pedal height, or in to increase brake pedal height. Both clevises must be turned the same amount.
6. Adjust the brake linkage so that the brake pedal travels no more than 1 in (25 mm) to fully engage the brakes. If the brake pedal travels more than 1 in (25 mm), it indicates the brake clevises are not adjusted the same. Readjust as necessary.
7. Reinstall the brake clevis pins.
8. Start the machine and raise the hopper.
9. Lower the hopper support bar.
10. Lower the hopper and turn off the machine.
11. Remove the machine tire blocks.

TIRES

All of the machine tires are solid. They should be inspected for wear after every 100 hours of operation.

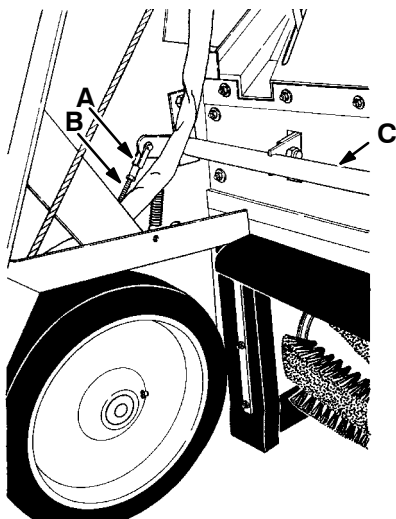

BRAKE CLEVIS

02457

- A. Brake Adjusting Clevis
- B. Threaded Rod
- C. Brake Cross Shaft

OPTIONS

SCRUB ATTACHMENT

The scrub attachment accessory gives the machine the added flexibility to scrub floors. It consists of three groups of parts – the scrub attachment, the side scrub brush and squeegee, and the rear squeegee. The scrub attachment includes two solution tanks, a solution distribution system, three scrub brushes, a recovery tank, and a debris hopper.

SOLUTION TANKS

The two solution tanks supply the scrub brush with a water and detergent solution. They are located in the top right and left sides of the scrub attachment.

Access to the tanks is through the solution tank covers on the top of the scrub attachment.

The solution tanks require no regular maintenance. If detergent cakes on the bottom of the tank, remove the deposits with a strong blast of water. Do not use water hotter than 130° F (54° C) or use steam to clean the tanks as it will damage them.

SOLUTION DISTRIBUTION SYSTEM

The solution is distributed by feed lines from the solution tanks to two cable controlled flow-rate valves, then to a solution spreader tube.

The solution spreader tube distributes scrub solution to the scrub brushes. It may be flushed out if it becomes clogged.

The spreader tube can be removed from the scrub attachment to be cleaned. Remove the solution hoses from the spreader tube. Remove the fitting from one end of the tube and slide the tube out of the mounting hangers. A brush and hot water may be needed to remove stubborn clogs. Do not use water hotter than 130° F (54° C). A sharp instrument may be used to clear the small distribution holes in the spreader tube.

SCRUB BRUSHES

Three scrub brushes are utilized by the scrub attachment – the side brush, the main brush, and a scrub brush located in the scrub attachment. The side brush scrubs and deflects debris into the path of the scrub brush. The scrub brush scrubs and deflects debris backward, the main brush scrubs and deflects debris into the debris hopper.

The brushes should be inspected daily for damage or wear. Remove any string or wire found tangled on the scrub brushes, drive, or idler hubs.

Replace the scrub brushes when the brush bristle is 0.5 in (15 mm) or less in length. To replace the side brush, see *TO REPLACE SIDE BRUSH*. To replace the scrub brush, see *TO REPLACE SCRUB BRUSH*. To replace the main brush, see *TO REPLACE MAIN BRUSH*.

The scrub brush patterns should be checked daily. They should be 2 to 3 in (50 to 75 mm) wide. The scrub brush pattern is adjusted by changing the position of the clevis on the threaded stud of the lift linkage. See *TO CHECK AND ADJUST SCRUB BRUSH PATTERN*.

MAINTENANCE

TO REPLACE SCRUB BRUSH

1. Start the machine, raise the scrub attachment, and engage the hopper support bar.

⚠ WARNING: Raised Hopper May Fall. Engage Hopper Support Bar.

2. Turn off machine and set parking brake.

FOR SAFETY: Before Leaving Or Servicing Machine; Stop On Level Surface, Set Parking Brake, And Turn Off Machine And Remove Key.

3. Remove the brush idler arm nut.

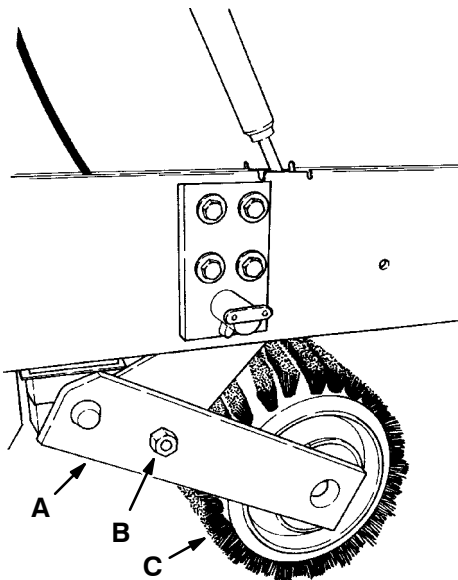

IDLER ARM

- A. Idler Arm
- B. Nut
- C. Scrub Brush

4. Pull the brush idler arm off the arm bracket.

5. Pull the scrub brush off the drive hub.

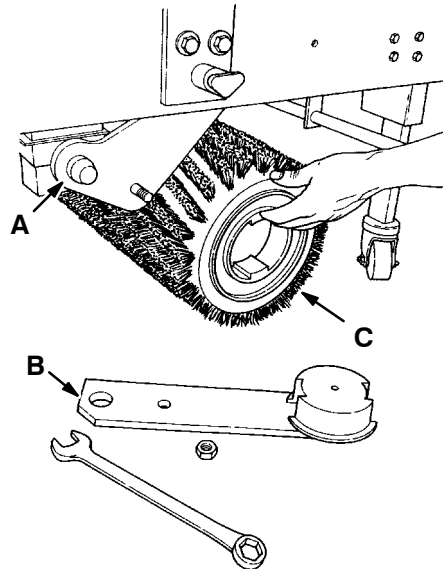

REMOVING SCRUB BRUSH

- A. Bracket
- B. Idler Arm
- C. Scrub Brush

6. Align the new scrub brush drive slots with the drive keys on the drive nuts.
7. Slide the scrub brush onto the drive hub.
8. Slide the idler hub onto the scrub brush and arm bracket.
9. Secure the idler arm with idler arm nut.
10. Check and adjust scrub brush pattern as described in *TO CHECK AND ADJUST SCRUB BRUSH PATTERN*.

02770

02778

TO CHECK AND ADJUST SCRUB BRUSH PATTERN

1. Apply chalk, or some other material that will not blow away easily, on a smooth, level floor.
2. With the scrub brush raised, move the scrub attachment over the test area. Set the parking brake.
3. Turn on the scrub brush with the scrubber brush switch.
4. Place the scrub brush position lever in the normal position for 15 to 20 seconds, then return the lever to the raised position.

NOTE: If no chalk or other material is available, allow the brushes to spin approximately two minutes. It will make a polish mark on the floor.

5. Turn off the scrub brush with the scrubber brush switch.
6. Release the parking brake and remove the machine from the test area.
7. The scrub brush pattern should be 2 in (50 mm) across the full length of the brush.

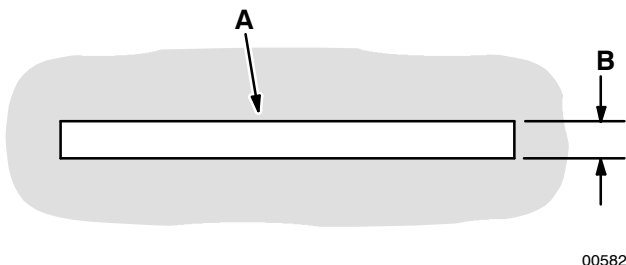

NORMAL SCRUB BRUSH PATTERN

- A. Scrub Brush Pattern**
- B. Pattern**

00582

To adjust the width of the pattern, adjust the position of the lift linkage clevis on the threaded stud. Thread the stud into the clevis to decrease the width. Thread the stud out of the clevis to increase the width.

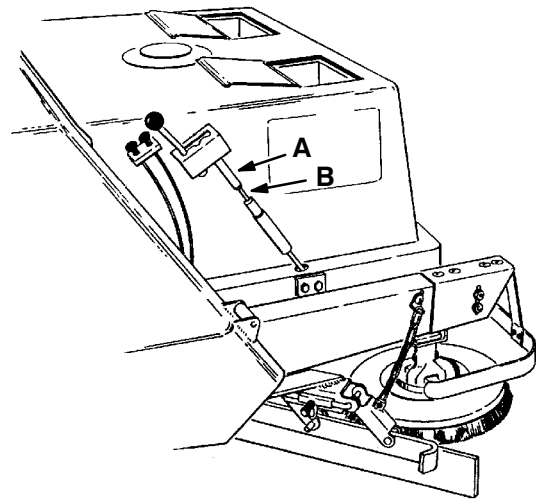

LIFT LINKAGE

05540

- A. Clevis**
- B. Stud**

If the brush pattern is tapered more than 0.25 in (5 mm), the scrub brush must be checked to see if it is cone shaped.

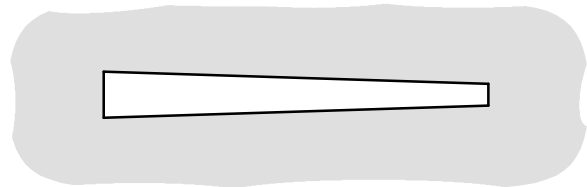

TAPERED SCRUB BRUSH PATTERN

00601

MAINTENANCE

If the brush is not cone shaped, the scrub brush drive mechanism must be leveled by adding or removing shims between the scrub brush cross shaft bearing blocks and the scrub attachment frame.

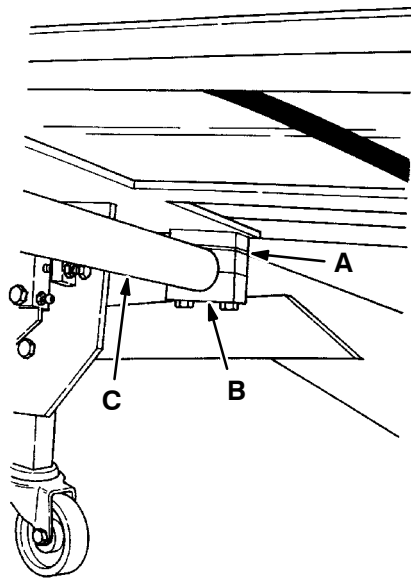

CROSS SHAFT SHIM

- A. Shim
- B. Bearing Block
- C. Cross Shaft

RECOVERY TANK

The machine recovery tank stores the water solution picked up by the machine squeegee and vacuum fan. The recovery tank is located under the solution tanks.

The recovery tank should be drained after the solution tank is empty or whenever the ball float rises and stops the water vacuum.

The recovery tank should be cleaned after every work shift.

Two clean-out doors have been provided to make the tank cleaning job easier. One door is located at the rear of the recovery tank. The other door is located at the front of the recovery tank.

Keep vacuum hoses and nozzles clean. Clogged hoses are a common cause of poor water pickup.

TO DRAIN THE RECOVERY TANK

1. Turn off the machine and set the machine parking brake.

FOR SAFETY: Before Leaving Or Servicing Machine; Stop On Level Surface, Set Parking Brake, And Turn Off Machine And Remove Key.

2. Open the front access door.
3. Remove the drain hose from its retention plug and lower it to a floor drain.

NOTE: The tank will not empty with the vacuum fan operating.

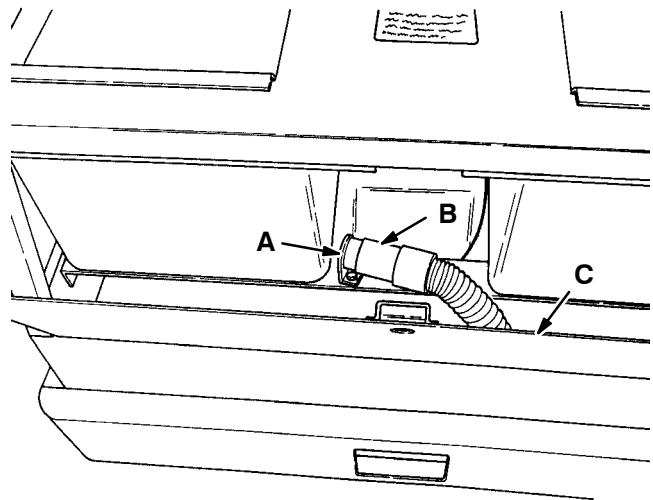

DRAIN HOSE

- A. Retention Plug
- B. Drain Hose
- C. Front Access Door

TO CLEAN THE RECOVERY TANK

1. Turn off the machine and set the machine parking brake.

FOR SAFETY: Before leaving or servicing machine; stop on level surface, set parking brake, and turn off machine and remove key.

2. Drain the recovery tank.
3. Open the front clean out doors by turning the door handles and pulling the doors away from the recovery tank.

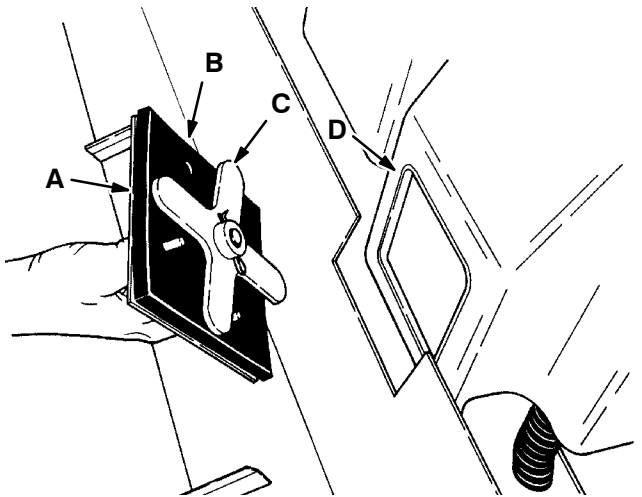

REAR CLEAN-OUT DOOR

02772

- A. Clean-Out Door**
- B. Door Seal**
- C. Door Fingers**
- D. Recovery Tank**

4. Spray the inside of the tank with clean water. Remove all sludge and debris from the bottom of the tank.
5. Spray the ball float. Make sure the float guides are free of dirt and debris which may cause the float to stick.
6. Close the clean-out doors by positioning the doors against the recovery tank, turning the door handles so the four fingers line up behind the tank wall, and tighten the lock knob.

DEBRIS HOPPER

The debris hopper collects debris picked up by the main and scrub brushes. It is located behind the scrub brush.

A vacuumized debris screen is located on the bottom of the debris hopper to draw water solution out of the debris collected in the hopper.

The debris hopper should be emptied whenever the recovery tank is drained. It should be sprayed clean daily.

To empty the debris hopper, raise the scrub attachment with the hopper lift and side brush lever. The debris will empty as the unit is lifted and tilted back.

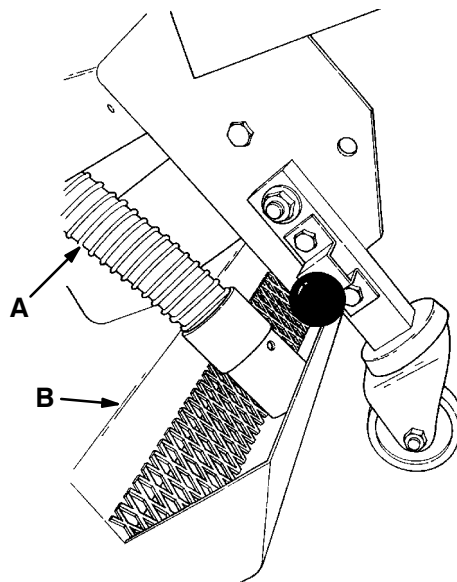

DEBRIS HOPPER

02754

- A. Vacuum Hose**
- B. Debris Hopper**

MAINTENANCE

The debris hopper is mounted by two pivoting points to allow it to float over large debris. It is equipped with float limiter. The lower limit bolt should be adjusted so the hopper has 0.3 in (10 mm) clearance with the floor. The upper limit bolt should be set so the hopper will travel up to a maximum of 1 in (25 mm) clearance.

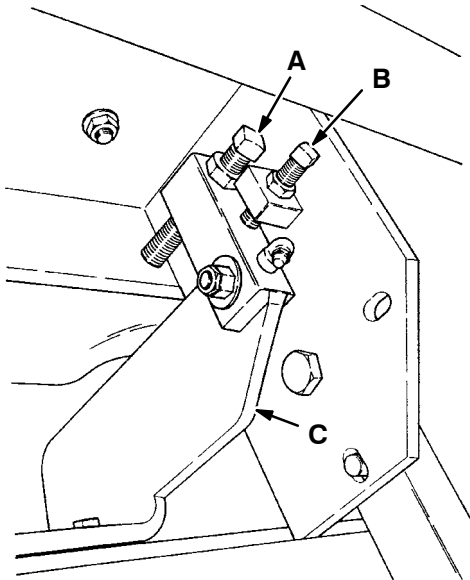

DEBRIS HOPPER LIMIT BOLTS

- A. Lower Limit Bolt
- B. Upper Limit Bolt
- C. Debris Hopper

SIDE SQUEEGEE

The side squeegee controls water spray and channels water into the path of the rear squeegee. Check the side squeegee for damage, wear and adjustment daily. Replace the squeegee whenever it becomes damaged or loses its shape or resiliency.

TO REPLACE SIDE SQUEEGEE BLADE

1. Turn off the machine and set the machine parking brake.

FOR SAFETY: Before Leaving Or Servicing Machine; Stop On Level Surface, Set Parking Brake, And Turn Off Machine And Remove Key.

2. Disconnect the squeegee assembly chain from the chain hook.

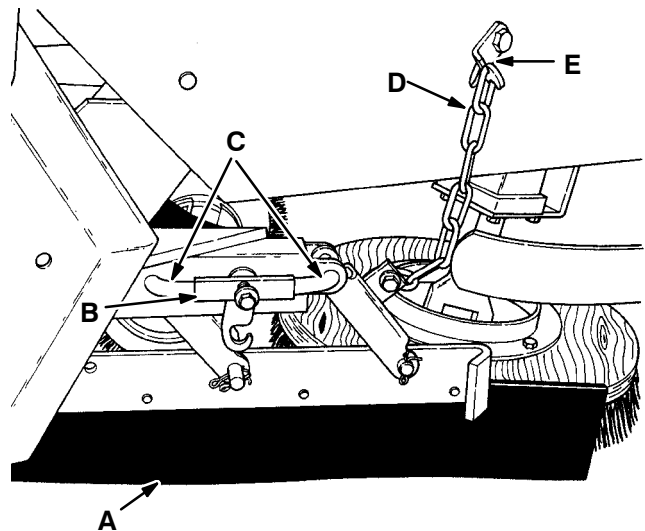

SIDE SQUEEGEE ASSEMBLY

- A. Squeegee Blade
- B. Pin Keeper
- C. Retaining Pin
- D. Chain
- E. Hook

3. Pull the pin keeper out and remove the two squeegee assembly retaining pins. Release the pin keeper.
4. Slide the squeegee assembly out of the machine.

5. Remove the five squeegee retaining screws from the squeegee assembly.
6. Remove the squeegee blade from the squeegee frame.
7. Position a new squeegee blade on the squeegee frame.
8. Secure the blade with the blade retainer and retaining screws.
9. Slide the squeegee assembly into position in the squeegee bracket.
10. Slide the two squeegee retaining pins through the bracket and squeegee assembly.

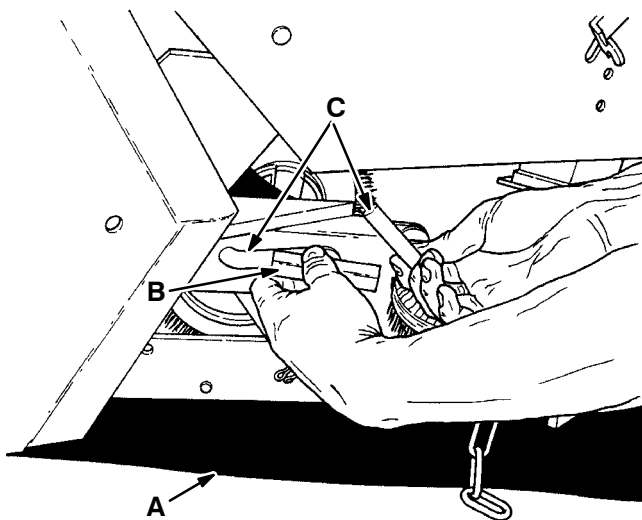

SECURING SQUEEGEE RETAINING PINS

- A. Squeegee Assembly**
- B. Pin Keeper**
- C. Pin**

11. Pull the pin keeper out, turn the squeegee retaining pins so they are under the pin keeper, and release the keeper.
12. Connect the squeegee assembly chain to the chain hook.

REAR SQUEEGEE

The rear squeegee assembly channels water into the vacuum fan suction. The front squeegee blade channels the water, and the rear blade wipes the floor. Check the rear squeegee assembly for damage, wear, and adjustment daily.

Rotate or replace the front or rear blade of the rear squeegee if its leading edge is worn one-half of the way through the thickness of the blade.

Each front and rear blade has two wiping edges. To use them, start with one wiping edge. To use the next wiping edge, swap the squeegee end-for-end. Replace the back-up strips if they become damaged, or if they lose their resiliency.

TO REPLACE OR ROTATE REAR BLADE

1. Turn off the machine and set the machine parking brake.

FOR SAFETY: Before Leaving Or Servicing Machine; Stop On Level Surface, Set Parking Brake, And Turn Off Machine And Remove Key.

2. Disconnect the suction hose from the rear squeegee assembly.
3. Remove the cotter pins from the clevis pins holding the rear squeegee frame to the machine frame and to the squeegee lift linkage.

MAINTENANCE

4. Pull out the clevis pins and remove the rear squeegee assembly from the machine frame and squeegee lift linkage.

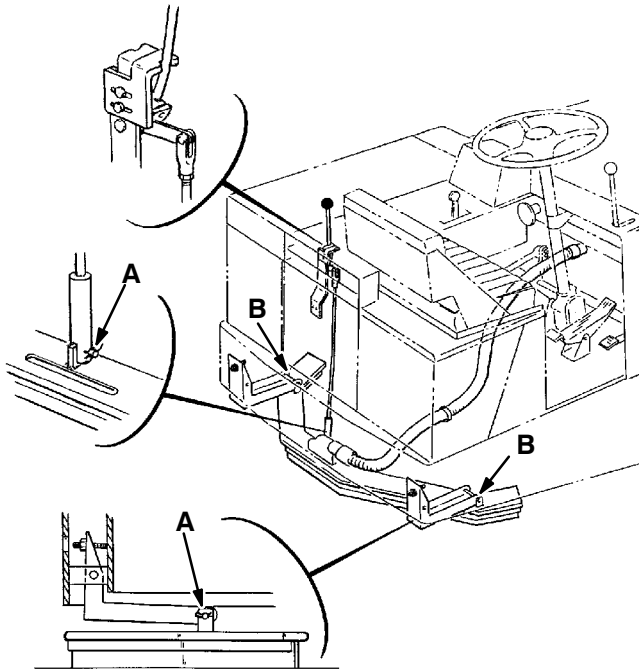

REMOVING REAR SQUEEGEE

05351

- A. Clevis Pins**
- B. Detach Squeegee Here**

5. Remove the retaining strips and screws holding the front and rear squeegee blades on the squeegee assembly frame.
6. Remove the back-up strip and then the rear squeegee blade. Remove the front squeegee blade.

7. Replace or rotate the squeegee blades. Place the back-up strip over the rear squeegee blade.
8. Position the retaining strips over the front and rear squeegees. Mount the squeegee blades with the retaining screws.
9. Place the rear squeegee assembly in the machine mounting brackets and mount with the clevis pins. Place the cotter pins in the clevis pins to secure the assembly in place.
10. Mount the squeegee lift linkage to the rear squeegee assembly with the clevis and cotter pins.
11. Adjust the rear squeegee as described in *TO CHECK AND ADJUST REAR SQUEEGEE*.

TO CHECK AND ADJUST REAR SQUEEGEE

1. Start the machine.
2. Lower the squeegee and move the machine forward on a level floor.
3. Turn off the machine and set the machine parking brake.

FOR SAFETY: Before Leaving Or Servicing Machine; Stop On Level Surface, Set Parking Brake, And Turn Off Machine And Remove Key.

4. Check the squeegee. It should contact the floor evenly side-to-side and deflect 0.75 in (20 mm) for smooth floors, and 1.25 in (30 mm) for rough floors. If not, continue with step 5.

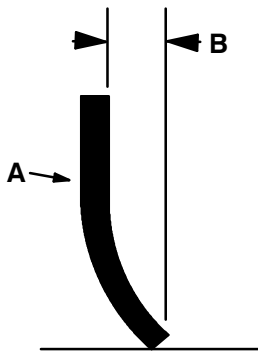

SQUEEGEE DEFLECTION

- A. Squeegee
- B. Deflection

NOTE: The squeegee blades must be new or have a new wiping edge contacting the floor to correctly adjust the squeegee.

5. To level the squeegee tips to the floor, adjust the squeegee assembly at the squeegee links.
6. To adjust the amount of deflection, adjust the down pressure of the squeegee assembly at the rear squeegee position lever.

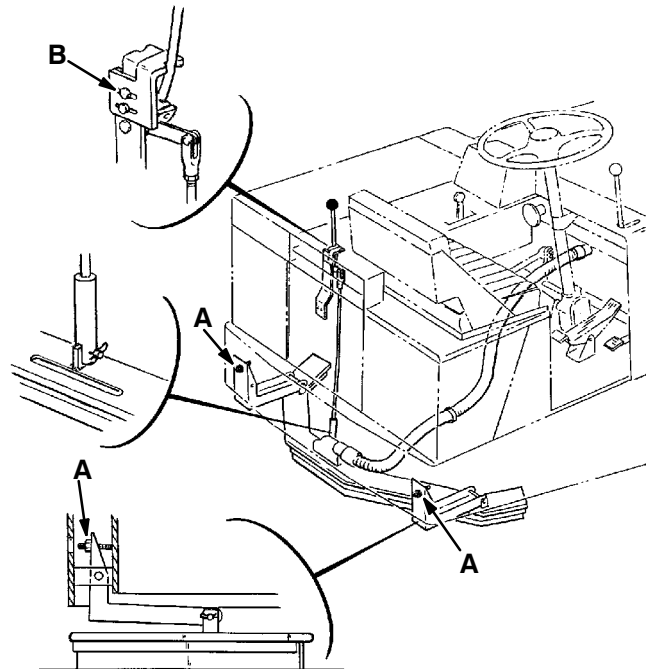

REAR SQUEEGEE ADJUSTMENTS

- A. Squeegee Tip Adjustment
- B. Squeegee Down Pressure Adjustment

03719

05351

SECTION 4

CONTENTS

	Page
HARDWARE INFORMATION	4-3
STANDARD BOLT TORQUE CHART	4-3
METRIC BOLT TORQUE CHART	4-3
BOLT IDENTIFICATION	4-3
THREAD SEALANT AND LOCKING COMPOUNDS	4-3
HYDRAULIC FITTING INFORMATION	4-4
HYDRAULIC TAPERED PIPE FITTING (NPT) TORQUE CHART	4-4
HYDRAULIC TAPERED SEAT FITTING (JIC) TORQUE CHART	4-4
HYDRAULIC O-RING FITTING TORQUE CHART	4-4

HARDWARE INFORMATION

The following charts state standard plated hardware tightening ranges for normal assembly applications. Decrease the specified torque by 20% when using a thread lubricant. Do not substitute lower grade hardware for higher grade hardware. If higher grade hardware than specified is substituted, tighten only to the specified hardware torque value to avoid damaging the threads of the part being threaded into, as when threading into speed nuts or weldments.

STANDARD BOLT TORQUE CHART

Thread Size	SAE Grade 5 Torque ft lb (Nm)	SAE Grade 8 Torque ft lb (Nm)
0.25 in	7–10 (9–14)	10–13 (14–38)
0.31 in	15–20 (20–27)	20–26 (27–35)
0.38 in	27–35 (37–47)	36–47 (49–64)
0.44 in	43–56 (58–76)	53–76 (72–103)
0.50 in	65–85 (88–115)	89–116 (121–157)
0.62 in	130–170 (176–231)	117–265 (159–359)
0.75 in	215–280 (291–380)	313–407 (424–552)
1.00 in	500–650 (678–881)	757–984 (1026–1334)

NOTE: Decrease torque by 20% when using a thread lubricant.

METRIC BOLT TORQUE CHART

Thread Size	Class 8.8 Torque ft lb (Nm)	Class 10.9 Torque ft lb (Nm)
M4	2 (3)	3 (4)
M5	4 (5)	6 (8)
M6	7 (9)	10 (14)
M8	18 (24)	25 (34)
M10	32 (43)	47 (64)
M12	58 (79)	83 (112)
M14	94 (127)	133 (180)
M16	144 (195)	196 (265)
M20	260 (352)	336 (455)
M24	470 (637)	664 (900)

NOTE: Decrease torque by 20% when using a thread lubricant.

Exceptions to the above chart:

Rear wheel hub nut – 200 to 250 ft lb (271 to 339 Nm)

Rear wheel lug nuts – 75 to 85 ft lb (102 to 115 Nm)

Vacuum fan impeller nut – 20 in lb (2 Nm)

Pump sheave bushing nuts – 108 in lb (12 Nm) alternating

Drive motor sheave bushing nuts – 80 in lb (9 Nm) alternating

BOLT IDENTIFICATION

Identification Grade Marking	Specification and Grade
------------------------------	-------------------------



SAE–Grade 5



SAE–Grade 8



ISO–Grade 8.8



ISO–Grade 10.9

01395

THREAD SEALANT AND LOCKING COMPOUNDS

Thread sealants and locking compounds may be used on this machine. They include the following:

Loctite 515 sealant – gasket forming material. TENNANT Part No. 75567, 15 oz (440 ml) cartridge.

Loctite 242 blue – medium strength thread locking compound. TENNANT Part No. 32676, 0.5 ml tube.

Loctite 271 red – high strength thread locking compound. TENNANT Part No. 19857, 0.5 ml tube.

HYDRAULIC FITTING INFORMATION

**HYDRAULIC TAPERED PIPE FITTING (NPT)
TORQUE CHART**

NOTE: Ratings listed are when using teflon thread seal.

Size	Minimum Torque	Maximum Torque
1/4 NPT	10 ft lb (14 Nm)	30 ft lb (41 Nm)
1/2 NPT	25 ft lb (34 Nm)	50 ft lb (68 Nm)
3/4 NPT	50 ft lb (68 Nm)	100 ft lb (136 Nm)

**HYDRAULIC TAPERED SEAT FITTING (JIC)
TORQUE CHART**

Tube O.D. (in)	Thread Size	Maximum Torque
0.25	0.44-20	9 ft lb (12 Nm)
0.38	0.56-18	20 ft lb (27 Nm)
0.50	0.75-16	30 ft lb (41 Nm)
0.62	0.88-14	40 ft lb (54 Nm)
0.75	1.12-12	70 ft lb (95 Nm)
1.0	1.31-12	90 ft lb (122 Nm)

HYDRAULIC O-RING FITTING TORQUE CHART

Tube O.D.(in)	Thread Size	Minimum Torque	Maximum Torque
0.25	0.44-20	6 ft lb (8 Nm)	9 ft lb (12 Nm)
0.38	0.56-18	13 ft lb (18 Nm) *10 ft lb (14 Nm)	20 ft lb (27 Nm) 12 ft lb (16 Nm)
0.50	0.75-16	20 ft lb (27 Nm) *21 ft lb (28 Nm)	30 ft lb (41 Nm) 24 ft lb (33 Nm)
0.62	0.88-14	25 ft lb (34 Nm)	40 ft lb (54 Nm)
0.75	1.12-12	45 ft lb (61 Nm)	70 ft lb (95 Nm)
1.0	1.31-12	60 ft lb (81 Nm)	90 ft lb (122 Nm)

NOTE: Do not use sealant on o-ring threads.

*Aluminum bodied components