

**FLOOREQUIPMENTPARTS.COM**



**235E**

(Operator Manual)

MM165



This manual is furnished with each new TENNANT Model 235E. It provides necessary operating and preventive maintenance instructions. Read this manual completely and understand the machine before operating or servicing it.

This manual covers all machine variations and standard accessories. The tabbed instruction portion of the manual consists of the Specification, Operation, Maintenance, and Appendix sections. The tabbed parts section consists of the Standard Model Parts; Options; Hydraulic Components; and Cross Reference sections.

All right side and left side references to the machine are determined by facing the direction of forward travel. All hardware considered to be of a common nature or locally available has been omitted from the parts sections. Be aware that this machine may contain metric hardware. Make sure you use equivalent hardware when replacement becomes necessary.

This machine will provide excellent service. However, the best results will be obtained at minimum costs if:

- The machine is operated with reasonable care.
- The machine is maintained regularly - per the maintenance instructions provided.
- The machine is maintained with Tennant Company supplied or equivalent parts.

Parts and supplies may be ordered by phone or mail from any Tennant Company parts and service center, distributor, or from any of the Tennant Company subsidiaries. Before ordering parts or supplies, be sure to have your machine model number and serial number handy. Fill out the data block below for future reference. The telephone numbers, telex numbers, mailing addresses, and locations of those outlets are listed in the Customer Documents section of the manual.

<b>MACHINE DATA</b>	
<i>Please fill out at time of installation.</i>	
Machine Serial Number -	_____
Engine Serial Number -	_____
Sales Representative -	_____
Customer Number -	_____
Date of Installation -	_____
Manual Number -	MM165
Revision:	09
Published:	8-95

**Trademark Registered in:** Austria, Benelux, Denmark, England, France, Germany, Italy, Spain, Switzerland, United States, Argentina, Australia, Canada, Japan, Mexico, Sweden, by TENNANT COMPANY, Minneapolis, Minnesota, U.S.A.

**Acknowledgements:** Technical information and/or illustrations supplied by Cessna Fluid Power Division; Eaton Corporation, Hydraulics Division.

Copyright 1986, 1987, 1988, 1989, 1991, 1993, 1994, 1995 Tennant Company, Printed in U.S.A.

## **ABOUT THIS MANUAL**

The machine manual that you received with your TENNANT machine contains valuable information about the operation and maintenance, and numerous sections filled with TENNANT part numbers for the repair of the machine. Please read through this section titled *ABOUT THIS MANUAL* to become familiar with the contents of the machine manual, making the information you are looking for easier to find.

The machine manual consists of several sections of reference information, and the remainder contain part number information for ordering repair parts for the machine. Each section has a shaded bar at the top of the page with the name of that section. Just as this section has the title *ABOUT THIS MANUAL* on the top of each page. This way you can tell which section you are in at all times.

### **REFERENCE SECTIONS**

The reference information sections of the manual are; General Information, Specifications, Operation, Maintenance, and Appendix.

*GENERAL INFORMATION* - The General Information section of the manual contains the safety precautions, the location of the safety labels on the machine, and a table of contents of the entire manual. The Safety Precautions are an overview of the safety measures to be observed when operating and maintaining your machine. The location of the safety labels show the mounting location of the safety labels for use in the replacement of the labels. The table of contents in this section is a list of all the table of contents that appear in the front of each section in the manual. This can be used for easy reference to locate information in a particular section of the manual.

*SPECIFICATIONS* - The Specifications section of the manual contains machine specification information useful in the operation and maintenance of the machine. This section gives you specification information on the engine, electric motors, brake system, hydraulics, fluid capacities, and machine weight to mention a few. The section also has a illustration of the top and side view of the machine with the height and width dimensions displayed.

*OPERATION* - The Operation section of the manual contains information needed to operate the machine. This section will list the controls and instruments on the machine, overview the machine operation, and tell you how to transport and store the machine.

*MAINTENANCE* - The Maintenance section contains information on the suggested maintenance procedures and adjustments to keep your machine in top operating condition. The section includes a Maintenance Chart listing the maintenance schedule and the areas of the machine to be addressed. Each subject of maintenance is covered in more detail in such areas as Lubrication, Hydraulics, Engine, and Electrical System.

*APPENDIX* - The Appendix contains hardware and hydraulic information. Standard hardware torques and identification information is included, plus hydraulic torques if your machine is hydraulically controlled.

### **PART SECTIONS**

The remaining sections of the manual contain part number information for ordering repair parts for your machine. The manual contains part number information on every type of machine model available in the model size of your particular machine. Therefore there will be part number information in your manual you will not need to refer to when wanting to place an order.

The main thing you need to know about your machine is what type of model is it. Is the machine powered by an engine or batteries? If the machine has an engine, is it fueled from gasoline, LPG, or diesel? If it is a mid-sized or larger sweeper, is it multi-level or low dump? For the scrubbers, is it SRS® or standard. Determining this information about your machine will help guide you through the separate parts sections to find the repair part you need.

## ABOUT THIS MANUAL

The smaller line of sweeper and scrubbers have less complicated part section arrangement, and are easier to find your way through the parts sections. The larger machines can have quite a variety of model types which significantly increases the size to the machine manual. Because of this, on the larger machine we made the first part section, Section 5, a part section which contains parts common to all type of the machine. If the machine has an engine, this section contains parts information on a gasoline powered machine.

The remaining sections contain only parts information which is unique to that particular machine type, such as unique diesel parts on the machine, or unique SRS® parts. Knowing the machine model type you have is important when searching for that part information you need for ordering repair parts. Start in that unique section first when looking for a part, then go to the first parts section, Section 5, if the part can't be found in the unique section.

### MACHINE SERIAL NUMBERS

When a design change takes place to a machine, the changes are indicated in the parts sections with machine serial numbers. Know the serial number of your machine which can be found on the machine data plate mounted on the machine. Record this number on the inside front cover of your manual along with your customer number.

Machine number usage is recorded in the *Machine Serial Number* column of the parts lists in the parts sections of the manual. If the machine serial number column lists zeros on the left side of the dash, then this part is used on all machines; such as (000000- ).

If the column lists zeros on the left of the dash and a number on the right of the dash, then the part is used on machines up to and including that machine serial number; such as (00000-002345).

For parts that are used on machines beginning at and continuing on from a certain serial number, the column would list a serial number on the left of the dash and have blank spaces on the right side of the dash; such as (002346- ). This part would be used on machines starting with that machine serial number and greater.

Finally, parts can be used on machines with serial numbers in a certain block of numbers. In this situation there is a serial number on the left and right side of the dash. The part is then used on a machine with a serial number starting at the number on the left and up to and including the number on the right; such as (002346-008900).

### PARTS ASSEMBLIES

A part assembly has parts within the assembly, such as a parking brake consisting of other smaller parts. What parts are contained in a part assembly can be determined by an indentation arrangement in the description column of the parts lists.

Here is an example of a part assembly, in this case we will use the parking brake mentioned previously:

Machine			
Serial Number	Description	Qty.	
(000000- )	Parking Brake	1	
(000000- )	Pin, Roll	1	
(000000- )	Link	1	
(000000- )	Spring, Compression	1	
(000000- )	Pin, Roll	1	
(000000- )	Support	1	
(000000- )	Lever, Release	1	
(000000- )	Rod, Parking Brake	1	
(000000- )	Washer, 0.50"	3	

In this example, the parts whose descriptions are indented under the parking brake are all parts of the parking brake. When you order the parking brake you will receive all the parts listed under it. You also can order any of the individual parts listed under the parking brake if it is the only part you need.

**SUPPLIER COMPONENT BREAKDOWNS**

TENNANT purchases certain components of the machine from suppliers. Some of these components are engines, hydraulic pumps and motors, electric motors, and solution pumps.

For those purchased components that are repairable, lists of parts for them appear in the later part of the parts sections. These are the supplier breakdowns. The engine breakdown contains both supplier and TENNANT parts numbers for repair parts. Breakdowns for hydraulic and electrical components have TENNANT part numbers for the parts TENNANT supplies. The serial numbers listed in any of the parts lists in these sections is a serial number the manufacturer uses to identify design changes in their particular component.

**ORDERING REPAIR PARTS**

Once you have located a part to order, there are several things you need to have to place the order. At the beginning of each parts section is an Ordering Repair Parts page which lists the information you will need to place your order. Review this list before placing the order.



## SAFETY PRECAUTIONS

The following symbols are used throughout this manual as indicated in their descriptions:



**WARNING:** To warn of hazards or unsafe practices which could result in severe personal injury or death.

**FOR SAFETY:** To identify actions which must be followed for safe operation of equipment.

The following information signals potentially dangerous conditions to the operator or equipment. Read this manual carefully. Know when these conditions can exist. Locate all safety devices on the machine. Then, take necessary steps to train machine operating personnel. Report machine damage or faulty operation immediately. Do not use the machine if it is not in proper operating condition.

**FOR SAFETY:**

1. **Do Not Operate Machine:**
  - Unless Trained And Authorized.
  - Unless Operation Manual Is Read And Understood.
  - In Flammable Or Explosive Areas Unless Designed For Use In Those Areas.
  - In Areas With Possible Falling Objects Unless Equipped With Overhead Guard.
2. **Before Starting Machine:**
  - Make Sure All Safety Devices Are In Place And Operate Properly.
  - Check Brakes And Steering For Proper Operation.
3. **When Starting Machine:**
  - Keep Foot On Brake And Directional Pedal In Neutral.
4. **When Using Machine:**
  - Use Brakes To Stop Machine.
  - Go Slow On Grades And Slippery Surfaces.
  - Use Care When Backing Machine.
  - Move Machine With Care When Hopper Is Raised.
  - Make Sure Adequate Clearance Is Available Before Raising Hopper.
  - Do Not Carry Riders On Machine.
  - Always Follow Safety And Traffic Rules.

5. **Before Leaving Or Servicing Machine:**
  - Stop On Level Surface.
  - Set Parking Brake.
  - Turn Off Machine And Remove Key.
6. **When Servicing Machine:**
  - Avoid Moving Parts. Do Not Wear Loose Jackets, Shirts, Or Sleeves When Working On Machine.
  - Block Machine Tires Before Jacking Machine Up.
  - Jack Machine Up At Designated Locations Only. Block Machine Up With Jack Stands.
  - Use Hoist Or Jack Of Adequate Capacity To Lift Machine.
  - Wear Eye And Ear Protection When Using Pressurized Air Or Water.
  - Avoid Contact With Battery Acid.
  - Use Cardboard To Locate Leaking Hydraulic Fluid Under Pressure.
  - Use TENNANT Supplied Or Equivalent Replacement Parts.
  - Disconnect Battery Connections Before Working On Machine.



**WARNING:** Batteries Emit Hydrogen Gas. Explosion Or Fire Can Result. Keep Sparks And Open Flame Away. Keep Covers Open When Charging.



**WARNING:** Lift Arm Pinch Point. Stay Clear Of Hopper Lift Arms When Hopper Is Moving.



**WARNING:** Falling Hopper. Engage Hopper Support Bar Before Working Under Hopper.



**WARNING:** Moving Belt. Keep Away.

# GENERAL INFORMATION

The following safety labels are mounted on the machine in the locations indicated. If these, or any, labels become damaged or illegible, install a new label in its place.

**FOR SAFETY LABEL - LOCATED ON THE SIDE OF THE CONTROL PANEL.**

**FOR SAFETY**

1. Do Not Operate Machine:
  - Unless Trained And Authorized.
  - Unless Operation Manual Is Read And Understood.
  - In Flammable Or Explosive Areas.
  - In Poorly Ventilated Areas.
2. Do Not Raise Hopper Without First Turning Off Main And Side Brushes.
3. Do Not Use Flammable Cleaning Agents.
4. Check For Fuel Leaks.
5. Go Slow On Grades And Slippery Surfaces.
6. Before Leaving Machine:
  - Stop On Level Surface
  - Stop Engine And Set Parking Brake
  - When Parking, Remove Key
7. Use Tennant Company Supplied Or Equivalent Replacement Parts.

03402

**FOR SAFETY THERMO SENTRY™ LABEL - LOCATED ON THE LIFT ARM CROSS MEMBER.**

**FOR SAFETY**

Check Fire Sensing Circuit Every 100 Hours.

1. Apply Heat To Sensor With Match Or Similar Device.
2. After Sensor Has Cooled Reset Circuit Breaker Located Behind Control Panel.
3. See Manual For Further Instructions.

03403

**CAUTION**

Explosive Gas Is Given Off By Batteries During Charge.

1. Keep Battery Compartment Cover Open.
2. No Smoking. Flame Or Sparks In Area.
3. Charge Only In Well Ventilated Area.

03400

03365

**EXPLOSIVE GAS CAUTION LABEL (2) - LOCATED ON THE INSIDE OF THE SEAT SUPPORT.**

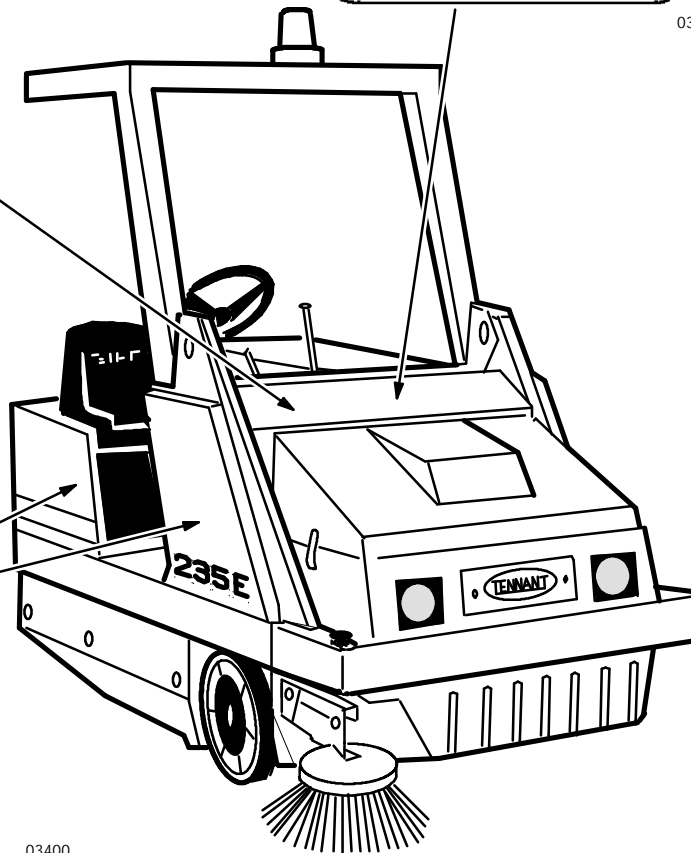



**HOPPER SUPPORT BAR WARNING LABEL -  
LOCATED ON THE OPERATOR SIDE OF  
HOPPER LIFT ARM.**

	<p><b>WARNING</b></p> <p><b>Engage Safety Support Bar Per Instructions Before Working Under Hopper</b></p>	<p><b>INSTRUCTIONS</b></p> <p> SAFETY SUPPORT BAR</p>	<p>To Engage Safety Support Bar:</p> <ol style="list-style-type: none"> <li>1. Lift Hopper To Extreme Up Position.</li> <li>2. Set Parking Brake.</li> <li>3. Dismount Machine And Lower Safety Support Bar Over Bar Stand.</li> <li>4. Lower Hopper Onto Support Bar.</li> <li>5. Shut Off Engine.</li> </ol>
--	--	---	--

03398

	<p><b>WARNING</b></p> <p><b>Keep Away From Fan Belt Drive.</b></p>
--	--

03397

**FAN BELT DRIVE WARNING LABEL -  
LOCATED ON THE VACUUM FAN.**

	<p><b>CAUTION</b></p> <p><b>Stay Clear Of Hopper Lift Arms.</b></p>
--	---

03401

**HOPPER LIFT ARM PINCH POINT CAUTION LABEL (2) -  
LOCATED ON THE HOPPER LIFT ARMS.**

	<p><b>WARNING</b></p> <p><b>Engage Safety Support Bar Per Instructions Before Working Under Hopper</b></p>
--	--

03399

**FALLING HOPPER WARNING LABEL -  
LOCATED ON THE FRONT OF THE BRUSH WRAP.**

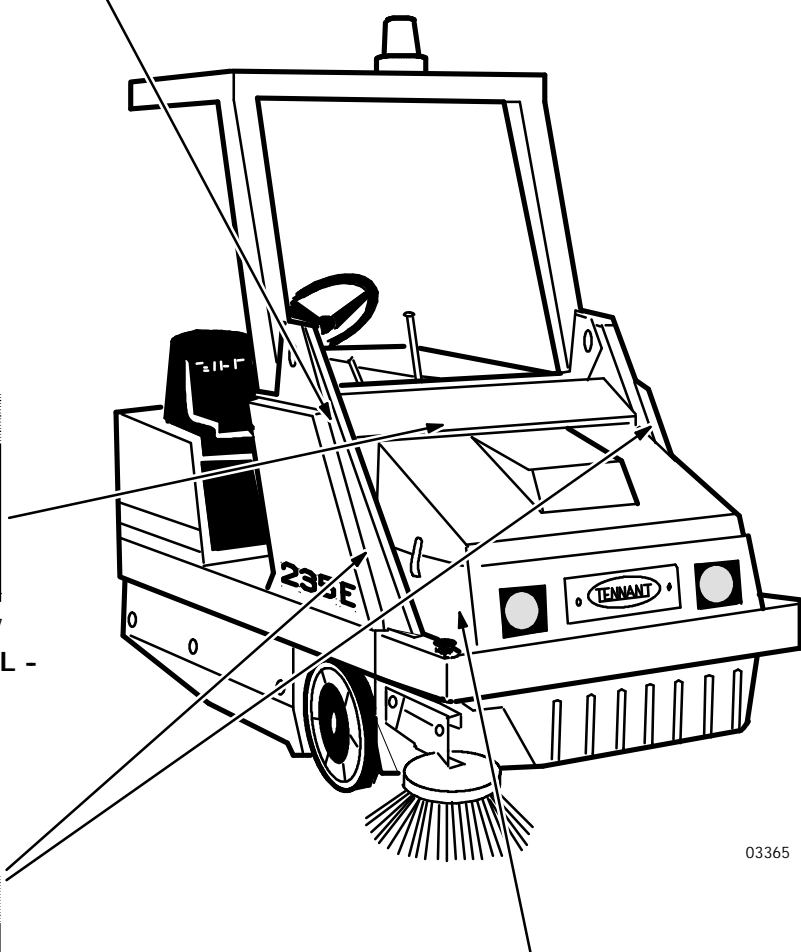

03365

**CONTENTS**

	Page		Page
GENERAL INFORMATION .....	i	MACHINE OPERATION .....	2-10
SAFETY PRECAUTIONS .....	i	NORMAL SWEEPING OPERATION .....	2-10
SPECIFICATIONS .....	1-1	PRE-START CHECKLIST .....	2-10
MACHINE SPECIFICATIONS .....	1-3	TO START MACHINE .....	2-10
POWER TYPE .....	1-3	TO SWEEP .....	2-10
POWER TRAIN .....	1-3	TO DUMP HOPPER .....	2-11
STEERING .....	1-3	POST OPERATION CHECKLIST -	
HYDRAULIC SYSTEM .....	1-3	MOTOR OPERATING ....	2-11
BRAKING SYSTEM .....	1-3	TO STOP MACHINE .....	2-11
SUSPENSION SYSTEM .....	1-3	POST OPERATION CHECKLIST -	
SYSTEM FLUID CAPACITIES .....	1-3	MOTOR STOPPED .....	2-11
GENERAL MACHINE DIMENSIONS -		TO ENGAGE HOPPER	
CAPACITIES .....	1-3	SUPPORT BAR .....	2-12
MACHINE WEIGHTS .....	1-3	TO DISENGAGE HOPPER	
GENERAL MACHINE		SUPPORT BAR .....	2-12
PERFORMANCE .....	1-3	OPERATION ON GRADES .....	2-12
MACHINE DIMENSIONS .....	1-4	MACHINE TROUBLESHOOTING ..	2-13
OPERATION .....	2-1	TRANSPORTING MACHINE .....	2-14
PREPARATION FOR OPERATION ....	2-3	PUSHING OR TOWING MACHINE .	2-14
AFTER UNCRATING AND BEFORE		MACHINE JACKING .....	2-14
OPERATING MACHINE: .....	2-3	TO JACK UP MACHINE .....	2-14
OPERATION OF CONTROLS .....	2-4	MACHINE TIE-DOWNS .....	2-15
MACHINE COMPONENTS .....	2-4	MACHINE STORAGE .....	2-16
CONTROLS AND INSTRUMENTS .	2-5	STORING MACHINE .....	2-16
BRAKE PEDAL .....	2-6	MAINTENANCE .....	3-1
DIRECTIONAL PEDAL .....	2-6	RECOMMENDED FIRST 50-HOUR	
PARKING BRAKE LEVER .....	2-6	MACHINE INSPECTION .....	3-3
OPERATOR SEAT .....	2-6	MAINTENANCE CHART .....	3-4
ADJUSTABLE SEAT LEVER (OPTION)	2-6	LUBRICATION .....	3-6
SEAT SUPPORT LEVER .....	2-6	GEARBOX .....	3-6
SIDE BRUSH AND HOPPER LEVER	2-6	REAR WHEEL SUPPORT BEARING	3-6
HOPPER DOOR SWITCH .....	2-6	SIDE BRUSH LEVER PIVOT .....	3-6
ACCESSORY SWITCH .....	2-6	STEERING LINKAGE .....	3-7
LIGHT SWITCH .....	2-7	HYDRAULICS .....	3-8
KEY-OPERATED ON-OFF SWITCH	2-7	HYDRAULIC FLUID .....	3-8
MAIN BRUSH LEVER .....	2-7	HYDRAULIC FLUID RESERVOIR ..	3-8
VACUUM LEVER .....	2-7	HYDRAULIC FILTER .....	3-9
HOUR METER .....	2-7	TO REPLACE FILTER ELEMENT	3-9
BATTERY CONDITION GAUGE ....	2-7	HYDRAULIC FLUID LEAKS .....	3-9
FLASHER SWITCH .....	2-7	HYDRAULIC SCHEMATIC .....	3-10
STEERING WHEEL .....	2-7	HYDRAULIC SYSTEM	
HORN BUTTON .....	2-7	TROUBLESHOOTING .....	3-11
SIDE BRUSH LEVER .....	2-8	HYDRAULIC COMPONENTS	
SIDE BRUSH ADJUSTMENT KNOB	2-8	TROUBLESHOOTING .....	3-12
AUXILIARY SIDE BRUSH			
IN-OUT SWITCH (OPTION) ....	2-8		
AUXILIARY SIDE BRUSH			
UP-DOWN SWITCH (OPTION) ..	2-8		
CIRCUIT BREAKERS AND FUSES .	2-9		
HOPPER SUPPORT BAR .....	2-9		

	Page		Page
ELECTRICAL SYSTEM .....	3-13	SKIRTS AND SEALS .....	3-33
BATTERIES .....	3-13	BRUSH SKIRTS .....	3-33
BATTERY CHARGING .....	3-14	TO REPLACE AND ADJUST	
ELECTRIC MOTORS .....	3-16	BRUSH SKIRTS .....	3-33
PROPELLING SYSTEM		REAR SKIRTS .....	3-33
TROUBLESHOOTING .....	3-17	TO REPLACE AND ADJUST	
PROPELLING CIRCUIT .....	3-18	REAR SKIRTS .....	3-33
TO ADJUST "NEUTRAL"		HOPPER LIP SKIRT .....	3-34
POSITION .....	3-18	TO REPLACE HOPPER	
ELECTRICAL SCHEMATIC (For machine		LIP SKIRT .....	3-34
below serial number 002205) ....	3-19	DUST SEALS .....	3-34
ELECTRICAL SCHEMATIC (For machines		TO REPLACE DUST SEALS ....	3-34
from serial number 002205		HOPPER DUMP DOOR SEAL .....	3-35
to 002310) .....	3-20	TO REPLACE HOPPER DUMP	
ELECTRICAL SCHEMATIC (For machines		DOOR SEAL .....	3-35
serial number 002311 and above)	3-21	VACUUM FAN SEAL .....	3-36
ELECTRICAL SCHEMATIC, AUXILIARY		FILTER COVER SEAL .....	3-36
SIDE BRUSH (For machines serial		BRAKES AND TIRES .....	3-37
number 002311 and above) ....	3-22	BRAKES .....	3-37
BELTS AND CHAINS .....	3-23	TIRES .....	3-37
HYDRAULIC PUMP BELT .....	3-23	REAR WHEEL .....	3-37
TO REPLACE AND ADJUST			
HYDRAULIC PUMP BELT ...	3-23	APPENDIX .....	4-1
VACUUM FAN BELT .....	3-24	HARDWARE INFORMATION .....	4-3
TO REPLACE AND ADJUST		STANDARD BOLT TORQUE CHART	4-3
VACUUM FAN BELT .....	3-24	METRIC BOLT TORQUE CHART ..	4-3
MAIN BRUSH BELT .....	3-25	BOLT IDENTIFICATION .....	4-3
TO REPLACE MAIN		THREAD SEALANT AND LOCKING	
BRUSH BELT .....	3-25	COMPOUNDS .....	4-3
TAPER LOCK BUSHINGS .....	3-26	HYDRAULIC FITTING INFORMATION .	4-4
TO REMOVE TAPER		HYDRAULIC TAPERED PIPE FITTING	
LOCK BUSHING .....	3-26	(NPT) TORQUE CHART .....	4-4
TO INSTALL TAPER		HYDRAULIC TAPERED SEAT FITTING	
LOCK BUSHING .....	3-26	(JIC) TORQUE CHART .....	4-4
STATIC DRAG CHAIN .....	3-26	HYDRAULIC O-RING FITTING	
DEBRIS HOPPER AND DUST FILTER .	3-27	TORQUE CHART .....	4-4
DEBRIS HOPPER .....	3-27		
TO CHECK AND ADJUST			
HOPPER FLOOR			
CLEARANCE .....	3-27		
THERMO SENTRY™ .....	3-27		
TO CHECK THE			
THERMO SENTRY™ .....	3-27		
HOPPER DUST FILTER .....	3-28		
TO REMOVE AND REPLACE			
HOPPER DUST FILTER .....	3-29		
BRUSHES .....	3-30		
MAIN BRUSH .....	3-30		
TO REMOVE MAIN BRUSH ....	3-30		
TO INSTALL MAIN BRUSH ....	3-30		
TO CHECK AND ADJUST MAIN			
BRUSH PATTERN .....	3-30		
SIDE BRUSH .....	3-32		
TO REMOVE SIDE BRUSH ....	3-32		
TO INSTALL SIDE BRUSH .....	3-32		

# GENERAL INFORMATION

	Page		Page
STANDARD MODEL PARTS .....	5-1	OPTIONS .....	6-1
ORDERING REPAIR PARTS .....	5-3	ORDERING REPAIR PARTS .....	6-3
Fig. 1 - Recommended General Maintenance Items .....	5-4	Fig. 1 - Cab Kit .....	6-4
Fig. 2 - Replacement Brushes .....	5-5	Fig. 2 - Overhead Guard Kit .....	6-6
Fig. 3 - Main Frame Group .....	5-6	Fig. 3 - Revolving Light Kit, Overhead Guard .....	6-7
Fig. 4 - Seat and Rear Shroud Group ..	5-8	Fig. 4 - Revolving Light Kit, Shroud ...	6-8
Fig. 5 - Front Wheel and Brake Group ..	5-10	Fig. 5 - Battery Kit, 295 A/h, Wet .....	6-9
Fig. 6 - Hopper Lift Arms Group .....	5-12	Fig. 6 - Battery Kit, 295 A/h, Dry, International Only .....	6-10
Fig. 7 - Hopper Middle and Cover Group	5-14	Fig. 7 - Battery Kit, 306 A/h, Wet .....	6-11
Fig. 8 - Hopper Bottom Group .....	5-16	Fig. 8 - Battery Kit, 306 A/h, Dry, International Only .....	6-12
Fig. 9 - Hopper Headlights and Access Door Group .....	5-18	Fig. 9 - Battery Installation Kit, 295 A/h	6-13
Fig. 10 - Hopper Filter and Shaker Motor Group .....	5-19	Fig. 10 - Battery Installation Kit, 306 A/h	6-14
Fig. 11 - Hopper Dump Door and Actuator Group .....	5-20	Fig. 11 - Battery Charger Group, 36A, 36V, 115 V .....	6-15
Fig. 12 - Vacuum Fan Control Group ...	5-22	Fig. 12 - Battery Charger Group, 40A, 36V, 50 Hz .....	6-16
Fig. 13 - Vacuum Fan Assembly .....	5-24	Fig. 13 - Battery Charger Group, 30A, 36V, 230V, 50Hz ....	6-17
Fig. 14 - Hydraulic Lift Cylinder and Filter Group .....	5-26	Fig. 14 - Battery Charger Group, 60A ..	6-18
Fig. 15 - Main Brush Drive Group .....	5-28	Fig. 15 - Battery Charger Group, 50A ..	6-19
Fig. 16 - Main Brush Idler Group .....	5-30	Fig. 16 - Demo Kit .....	6-20
Fig. 17 - Side Brush Group .....	5-32	Fig. 17 - Adjustable Seat Kit .....	6-21
Fig. 18 - Main Brush Motor and Hydraulic Pump Group ....	5-34	Fig. 18 - Auxiliary Side Brush Group ...	6-22
Fig. 19 - Hopper Control Valve Group ..	5-36	Fig. 19 - Auxiliary Side Brush Hydraulic Hose Group ....	6-24
Fig. 20 - Hydraulic Hoses Group .....	5-37	Fig. 20 - Auxiliary Side Brush Electrical Group .....	6-25
Fig. 21 - Steering Wheel Group .....	5-38		
Fig. 22 - Directional Pedal Group .....	5-40	HYDRAULIC COMPONENTS	
Fig. 23 - Rear Drive Wheel Group .....	5-42	ORDERING REPAIR PARTS .....	7-3
Fig. 24 - Control Panel Group .....	5-44	Fig. 1 - Hydraulic Power Unit Breakdown, 87340 .....	7-4
Fig. 25 - Electrical Component Plate Group .....	5-46	Fig. 2 - Hydraulic Motor Breakdown, 87475 .....	7-5
Fig. 26 - Control Box Group .....	5-48	Fig. 3 - Hydraulic Valve Breakdown, 87409 .....	7-6
Fig. 27 - Control Box Group .....	5-50	Fig. 4 - Hydraulic Motor Breakdown, 28804 .....	7-7
Fig. 28 - Wire Harness Group .....	5-52	Fig. 5 - Hydraulic Lift Cylinder Breakdown, 87055 .....	7-8
Fig. 29 - Labels Group .....	5-54	Fig. 6 - Hydraulic Lift Cylinder Breakdown, 48575 .....	7-9
		Fig. 7 - Hydraulic Lift Cylinder Breakdown, 65223 .....	7-10
		CROSS REFERENCE .....	8-1
		PART NUMBER TO PAGE NUMBER CROSS REFERENCE LIST .....	8-3

**SECTION 1****CONTENTS**

	Page
MACHINE SPECIFICATIONS .....	1-3
POWER TYPE .....	1-3
POWER TRAIN .....	1-3
STEERING .....	1-3
HYDRAULIC SYSTEM .....	1-3
BRAKING SYSTEM .....	1-3
SUSPENSION SYSTEM .....	1-3
SYSTEM FLUID CAPACITIES .....	1-3
GENERAL MACHINE DIMENSIONS - CAPACITIES .....	1-3
MACHINE WEIGHTS .....	1-3
GENERAL MACHINE PERFORMANCE	1-3
MACHINE DIMENSIONS .....	1-4



**MACHINE SPECIFICATIONS**

**POWER TYPE**

Electric propelling motor - nominal voltage  
36 VDC, 1.2 hp (0.9 kw) @ 2550 rpm, 34 A  
Electric accessories motor - nominal voltage  
36 VDC, 1.9 hp (1.4 kw) @ 2500 rpm, 52 A  
Batteries, standard (6) - 6 V, 295 A/h @  
6 hour rate  
Batteries, heavy duty (2) - 18 V, 306 A/h @  
4 hour rate  
Battery charger - 36 VDC 40 A, 115 VAC 60 hz  
36 VDC 60 A, 208-230 VAC 60 hz  
36 VDC 40 A, 230 VAC 50 hz

**POWER TRAIN**

Propelling - electric motor driven  
Main brush - belt driven  
Side brush - hydraulic motor driven  
Vacuum fan - belt driven  
Hydraulic pump - belt driven

**STEERING**

Type - rear wheel controlled, automotive cam  
and lever  
Power source - manual

**HYDRAULIC SYSTEM**

Function - operates hopper lift, side brush drive  
  
Control valve, hopper lift, side brush drive - open  
center, single spool type  
  
Pump - gear type, 0.26 cu in (4 cc) displacement  
per revolution, 1350 psi (9310 kPa)  
@ 1.0 gpm (3.8 L/min) relief setting  
  
Motor, side brush - internal gear type, 2.8 cu in  
(46 cc) per revolution, 2500 psi (17,240 kPa)  
maximum rated pressure  
  
Cylinder, hopper lift - single action type, 2.5 in  
(65 mm) bore x 12 in (305 mm) stroke,  
1.125 in (30 mm) diameter rod, 3000 psi  
(20,685 kPa) maximum rated pressure.  
  
Filter - spin-on type, 10 micron nominal, 25 psi  
(170 kPa) bypass pressure

**BRAKING SYSTEM**

Service brakes - mechanical drum brakes (2) -  
1 per front wheel, linkage actuated  
Parking brakes - utilizes service brakes, linkage  
actuated

**SUSPENSION SYSTEM**

Front - 15 x 3.00 solid tires (2)  
Rear - 16 x 4.00 solid tire (1)

**SYSTEM FLUID CAPACITIES**

Hydraulic system - reservoir 1 gal (3.8 L)  
Hydraulic system - total 1.25 gal (4.7 L)  
Gearbox grease capacity - 2.7 qt (2.6 L)

**GENERAL MACHINE DIMENSIONS -  
CAPACITIES**

Length - 77.5 in (1970 mm)  
Width with side brush - 48 in (1220 mm)  
Height less overhead guard - 53 in (1345 mm)  
Height with overhead guard - 79.5 in (2020 mm)  
Track - front 44 in (1115 mm)  
Wheel base - 41 in (1040 mm)  
Main brush - width 36 in (915 mm)  
Main brush - outside diameter 14 in (355 mm)  
Side brush - rotary diameter 19 in (480 mm)  
Sweeping path width (total) - 48 in (1220 mm)  
Hopper capacity - 10 cu ft (0.28 m<sup>3</sup>) 650 lb  
(295 kg)  
Dust filter - 49 sq ft (4.5 m<sup>2</sup>), pleated panel filter  
element

**MACHINE WEIGHTS**

Net weight, dry - 2500 lb (1135 kg)  
GVWR - 3400 lb (1540 kg)

**GENERAL MACHINE PERFORMANCE**

Maximum forward speed - 5 mph (8 km/h)  
Maximum reverse speed - 3 mph (5 km/h)  
Maximum forward speed with raised hopper -  
2 mph (3.2 km/h)  
Turning radius - left, 60 in (1525 mm) right, 78 in  
(1980 mm)  
Maximum rated climb and descent angle - 10°

**MACHINE DIMENSIONS**

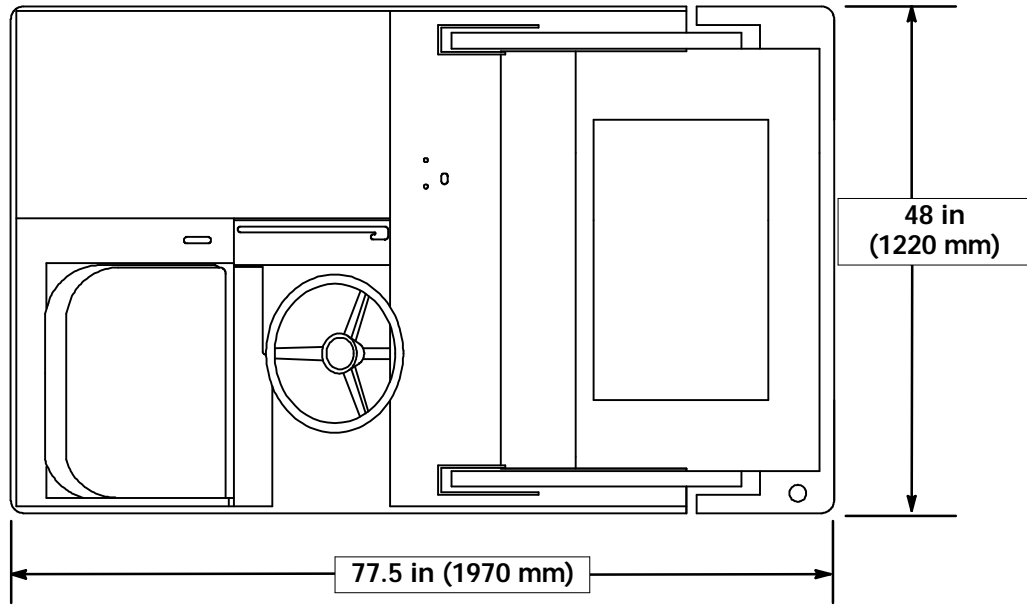

**TOP VIEW**

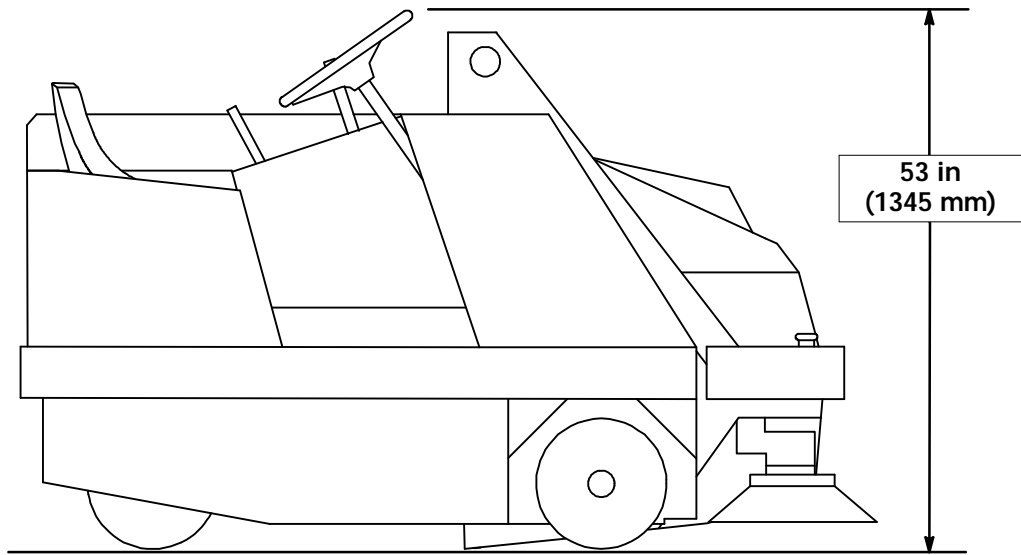

**SIDE VIEW**

03366



## SECTION 2

## CONTENTS

	Page		Page
PREPARATION FOR OPERATION .....	2-3	MACHINE OPERATION .....	2-10
AFTER UNCRATING AND BEFORE		NORMAL SWEEPING OPERATION ...	2-10
OPERATING MACHINE: .....	2-3	PRE-START CHECKLIST .....	2-10
OPERATION OF CONTROLS .....	2-4	TO START MACHINE .....	2-10
MACHINE COMPONENTS .....	2-4	TO SWEEP .....	2-10
CONTROLS AND INSTRUMENTS ....	2-5	TO DUMP HOPPER .....	2-11
BRAKE PEDAL .....	2-6	POST OPERATION CHECKLIST -	
DIRECTIONAL PEDAL .....	2-6	MOTOR OPERATING .....	2-11
PARKING BRAKE LEVER .....	2-6	TO STOP MACHINE .....	2-11
OPERATOR SEAT .....	2-6	POST OPERATION CHECKLIST -	
ADJUSTABLE SEAT LEVER (OPTION)	2-6	MOTOR STOPPED .....	2-11
SEAT SUPPORT LEVER .....	2-6	TO ENGAGE HOPPER SUPPORT BAR	2-12
SIDE BRUSH AND HOPPER LEVER ..	2-6	TO DISENGAGE HOPPER	
HOPPER DOOR SWITCH .....	2-6	SUPPORT BAR .....	2-12
ACCESSORY SWITCH .....	2-6	OPERATION ON GRADES .....	2-12
LIGHT SWITCH .....	2-7	MACHINE TROUBLESHOOTING ....	2-13
KEY-OPERATED ON-OFF SWITCH ...	2-7	TRANSPORTING MACHINE .....	2-14
MAIN BRUSH LEVER .....	2-7	PUSHING OR TOWING MACHINE ....	2-14
VACUUM LEVER .....	2-7	MACHINE JACKING .....	2-14
HOUR METER .....	2-7	TO JACK UP MACHINE .....	2-14
BATTERY CONDITION GAUGE .....	2-7	MACHINE TIE-DOWNS .....	2-15
FLASHER SWITCH .....	2-7	MACHINE STORAGE .....	2-16
STEERING WHEEL .....	2-7	STORING MACHINE .....	2-16
HORN BUTTON .....	2-7		
SIDE BRUSH LEVER .....	2-8		
SIDE BRUSH ADJUSTMENT KNOB ...	2-8		
AUXILIARY SIDE BRUSH			
IN-OUT SWITCH (OPTION) .....	2-8		
AUXILIARY SIDE BRUSH			
UP-DOWN SWITCH (OPTION) ....	2-8		
CIRCUIT BREAKERS AND FUSES ....	2-9		
HOPPER SUPPORT BAR .....	2-9		



**PREPARATION FOR OPERATION**

**AFTER UNCRATING AND BEFORE OPERATING MACHINE:**

1. Check the machine for shipping damage.
2. Read this manual carefully before operating or servicing the machine.

**FOR SAFETY: Do Not Operate Machine Unless Operation Manual Is Read And Understood.**

3. Open the seat support.
4. Check the batteries electrolyte level as described in *BATTERIES* in the *MAINTENANCE* section.

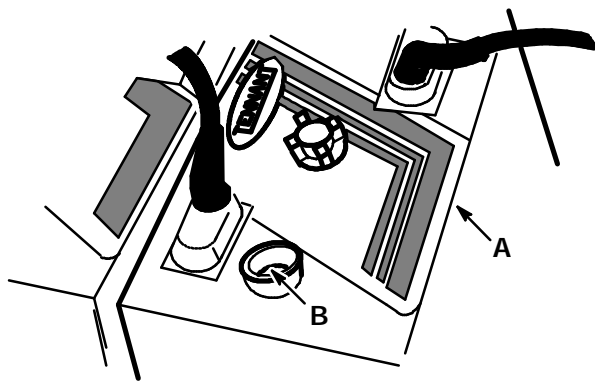

00879

**CHECKING BATTERY ELECTROLYTE LEVEL**

- A. Battery
- B. Electrolyte Indicator Ring

**FOR SAFETY: When Servicing Machine, Avoid Contact With Battery Acid.**

5. Check the battery specific gravity to determine the state of charge as described in *BATTERIES* in the *MAINTENANCE* section. Charge the batteries if necessary.

6. Connect the battery connector to the machine connector.

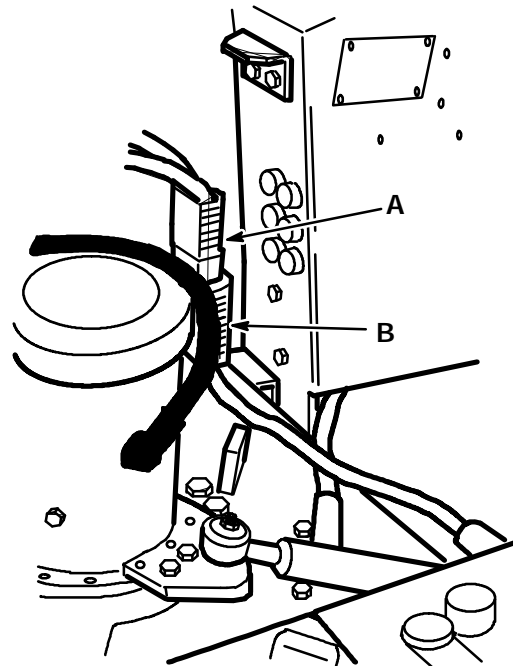

03367

**BATTERY CONNECTOR**

- A. Machine Connector
- B. Battery Connector

7. Check the hydraulic fluid level in the hydraulic fluid reservoir. See *HYDRAULICS* in the *MAINTENANCE* section.
8. Check the main brush adjustment. See *BRUSHES* in the *MAINTENANCE* section.

OPERATION OF CONTROLS

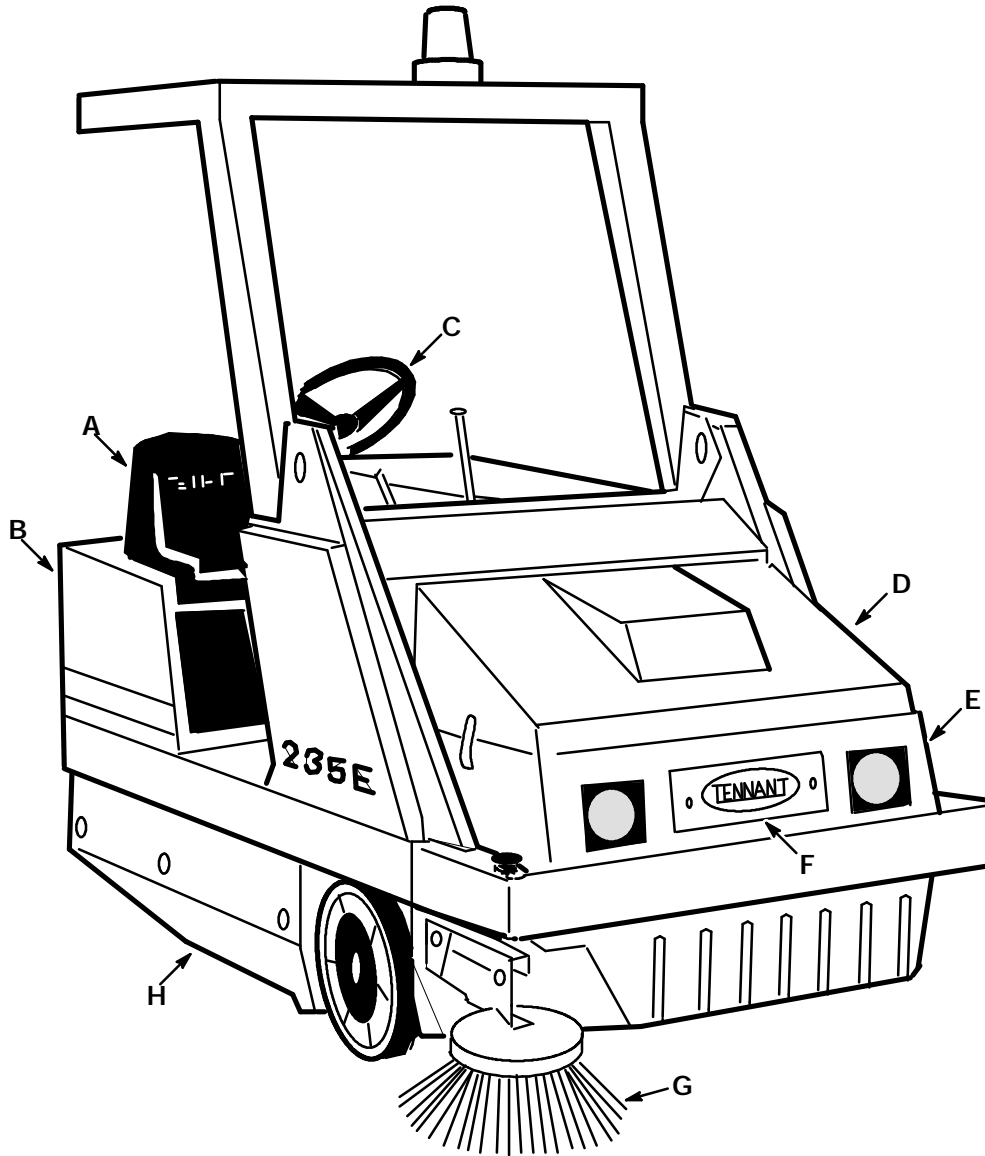

MACHINE COMPONENTS

- |                   |                           |
|-------------------|---------------------------|
| A. Operator Seat  | E. Hopper                 |
| B. Seat Support   | F. Hopper Inspection Door |
| C. Steering Wheel | G. Side Brush             |
| D. Filter Cover   | H. Access Door            |

03365

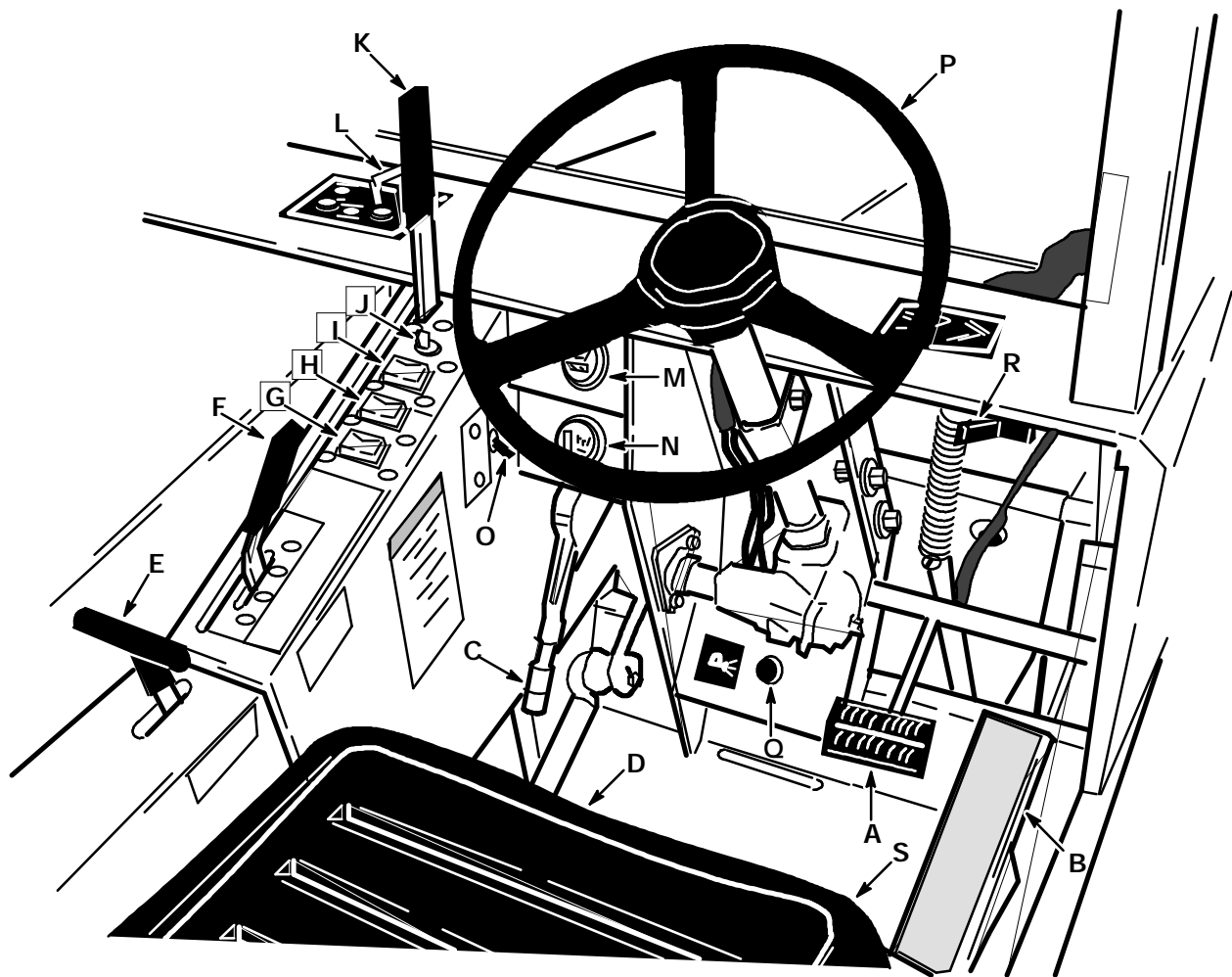

## CONTROLS AND INSTRUMENTS

03368

- |                                |                                  |
|--------------------------------|----------------------------------|
| A. Brake Pedal                 | J. Key-Operated On-Off Switch    |
| B. Directional Pedal           | K. Main Brush Lever              |
| C. Parking Brake Lever         | L. Vacuum Lever                  |
| D. Operator Seat               | M. Hour Meter                    |
| E. Seat Support Lever          | N. Battery Condition Gauge       |
| F. Side Brush and Hopper Lever | O. Flasher Switch                |
| G. Hopper Door Switch          | P. Steering Wheel                |
| H. Accessory Switch            | Q. Horn Button                   |
| I. Light Switch                | R. Side Brush Lever              |
|                                | S. Auxiliary Side Brush Switches |

## BRAKE PEDAL

The brake pedal operates the brakes on the two front wheels. To stop the machine, return the direction pedal to neutral, then apply pressure to the brake pedal.

## DIRECTIONAL PEDAL

The directional pedal controls the propelling drive. The pedal is used to select the direction of travel and the speed of the machine.

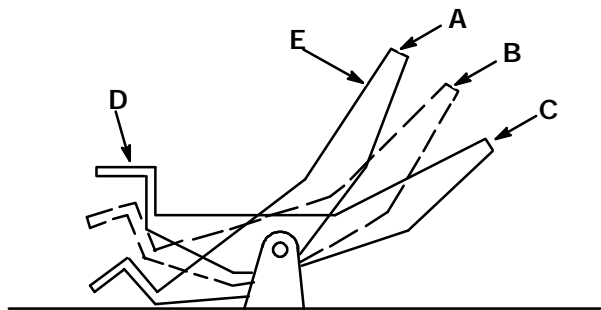

**DIRECTIONAL PEDAL POSITIONS**

00116

- A. "Reverse" Position
- B. "Neutral" Position
- C. "Forward" Position
- D. "Heel" Position
- E. "Toe" Position

Gradually press the "toe" portion of the pedal for forward travel or the "heel" portion for reverse travel. Regulate the machine speed by varying the pressure on the directional pedal.

The machine will coast for a short distance before changing direction when the machine is moving and the directional pedal is reversed. Use the brakes to stop the machine.

**FOR SAFETY: When Using Machine, Use Brakes To Stop Machine.**

## PARKING BRAKE LEVER

The parking brake lever operates the front wheel brakes. To set the parking brake, pull the handle up. To release the parking brake, push the handle down. Always park on a level surface, stop the engine, and set the parking brake before leaving the machine unattended and before working on the machine.

**FOR SAFETY: Before Leaving Or Servicing Machine; Stop On Level Surface, Set Parking Brake, Turn Off Machine And Remove Key.**

## OPERATOR SEAT

The operator seat is of the fixed-back style with a forward-backward adjustment. To adjust the seat, remove the seat mounting bolts, slide the seat to the position desired, and reinstall and tighten the bolts. The seat support has a cutout switch that stops the machine whenever the seat support is not down.

## ADJUSTABLE SEAT LEVER (OPTION)

The adjustable seat lever option controls the front-to-rear position of the seat. Pull the lever out, slide the seat backward or forward to the desired position and release the lever.

## SEAT SUPPORT LEVER

The seat support lever locks the seat support down. To raise the seat support, pull the lever and seat support back. To lower the seat support, hold on to the lever and lower the seat support. Do not let the seat support drop or machine damage may occur.

## SIDE BRUSH AND HOPPER LEVER

The side brush and hopper lever controls side brush rotation and hopper position. To start the side brush turning, push the lever forward into the "ON" position. To stop the side brush, pull the lever back into the "LOWER" position. To raise the hopper, pull the lever back into the "LIFT" position. To hold the hopper in any raised position, pull the lever back into the "HOLD" position. To lower the hopper, push the lever forward into the "LOWER" position.

## HOPPER DOOR SWITCH

The hopper door switch controls the hopper door. To open the hopper door, press and hold the switch in the "OPEN" position until a ratcheting noise is heard. To close the hopper door, press and hold the switch in the "CLOSE" position until a ratcheting noise is heard. The hopper door should always be open except when high dumping the hopper.

## ACCESSORY SWITCH

The accessory switch controls the electric motor that drives the main brush, the vacuum fan, and the hydraulic accessory pump. The pump supplies hydraulic fluid to the side brush motor and the hopper lift cylinder. The accessory switch must be in the "ON" position to operate any of these components.

**LIGHT SWITCH**

The light switch operates the head lights and the tail lights. To operate the lights, move the switch to the "ON" position. To turn the lights off, move the switch to the "OFF" position.

**KEY-OPERATED ON-OFF SWITCH**

The key-operated on-off switch has two positions-- "OFF" and "ON." To allow the motors to start, turn the key fully clockwise to the "ON" position. The motors may not start up right away as they have individual controls. To stop the motors, turn the key to the "OFF" position.

**MAIN BRUSH LEVER**

The main brush lever controls the position and the drive of the main brush. To raise the main brush, push the lever all the way forward into the "UP" position. To lower the main brush, push the lever forward and to the left, and release it.

When parking the machine, always raise the brush to prevent the bristles from taking a set.

**VACUUM LEVER**

The vacuum lever controls the vacuum that is applied to the hopper. The lever also controls the dust filter shaker. When sweeping dry debris, place the lever in the "Normal Sweeping" position. When sweeping wet debris, place the lever in the "Wet Sweeping" position. To shake the dust filter, place and hold the lever in the "Filter Shaker" position for 20 seconds.

**HOUR METER**

The hour meter records the number of hours the machine has operated. This information is useful in determining when to service the machine.

**BATTERY CONDITION GAUGE**

The battery condition gauge indicates the present state of charge of the batteries. The display should be on the F mark of the gauge when the batteries are fully charged. As the batteries discharge, the display will move down near the E mark and start to blink. The batteries should be recharged when the display gets to the 1/4 mark.

When the machine is left overnight with less than a full charge, the display may indicate a full charge because of the surface charge level. After running the machine a few minutes, the gauge will give the correct charge level.

*NOTE: Do not charge the batteries more often than is necessary. This will prolong the life of the batteries. Do not allow the batteries to become fully discharged as this will also damage the batteries. See BATTERIES in the MAINTENANCE section.*

**FLASHER SWITCH**

The flasher switch is present on machines with the flashing light option. To operate the flashing light, move the switch to the "ON" position. To stop the light, move the switch to the "OFF" position.

**STEERING WHEEL**

The steering wheel controls the rear caster wheel. The machine is very responsive to the movement of the steering wheel. The operator should use care until he or she becomes experienced in guiding the machine.

**HORN BUTTON**

The horn button operates the machine horn. It is located to the left of the foot brake pedal.

## OPERATION

### SIDE BRUSH LEVER

The side brush lever controls the position of the side brush. To raise the side brush, pull the lever into the "Raised" position. To lower the brush, push the lever down and release it into the "Down" position.

When the machine is parked, always raise the brush to prevent the bristles from taking a set.

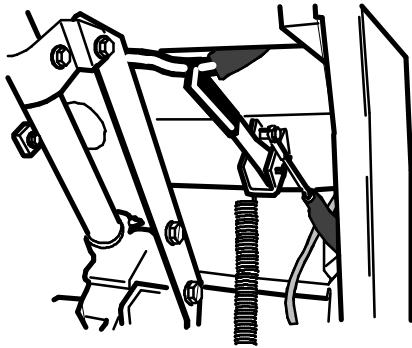

SIDE BRUSH LEVER

03396

### SIDE BRUSH ADJUSTMENT KNOB

The side brush adjustment knob controls the height of the side brush when it is in the "Down" position. To reduce the brush pattern and the side brush contact with the floor, turn the knob to the right. To increase the brush pattern and the side brush contact with the floor, turn the knob to the left.

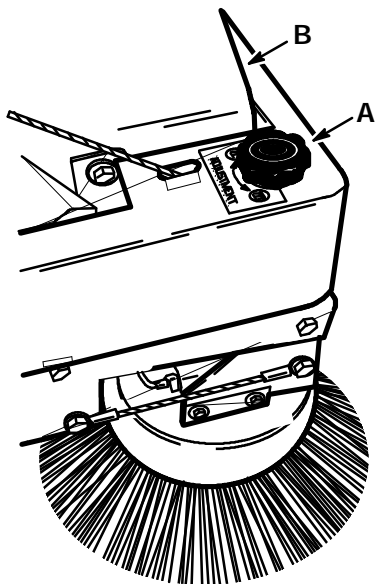

SIDE BRUSH ADJUSTMENT KNOB

03386

- A. Side Brush Adjustment Knob
- B. Hopper

### AUXILIARY SIDE BRUSH IN-OUT SWITCH (OPTION)

The auxiliary side brush in-out switch controls the in and out movement of the auxiliary side brush option. To move the brush in, press the top of the in-out switch. To move the brush out, press the bottom of the in-out switch.

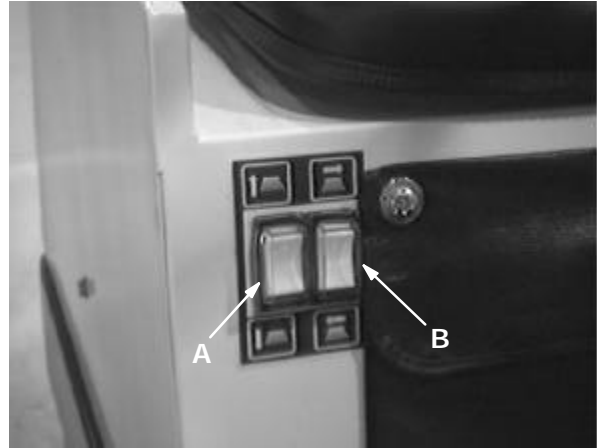

AUXILIARY SIDE BRUSH SWITCHES

- A. Up-Down Switch
- B. In-out Switch

### AUXILIARY SIDE BRUSH UP-DOWN SWITCH (OPTION)

The auxiliary side brush up-down switch controls the up and down movement of the auxiliary side brush option. To raise the brush, press the top of the up-down switch. To lower the brush, press the bottom of the up-down switch.



**CIRCUIT BREAKERS AND FUSES**

Circuit breakers are resettable circuit protection devices designed to stop the flow of current in the event of a circuit overload. Once tripped, circuit breakers must be manually reset. If the overload which caused the circuit breaker to trip is still present in the circuit, the circuit breaker will continue to stop current flow until the overload is corrected.

Fuses are a one-time circuit protection device designed to stop the flow of current in the event of a circuit overload. Never substitute higher value fuses than those specified in this manual.

The circuit breakers are located on the instrument panel bracket under the seat support. The fuses are located in the speed controller box.

The following chart shows the various circuit breakers and fuses, and the electrical components they protect.

PROTECTIVE DEVICE	RATING	CIRCUIT PROTECTED
CB-1	10 A	Battery gauge, Accessories
CB-2	10 A	Horn
CB-3	10 A	Filter Shaker
CB-4	10 A	Hopper Dump Door
CB-5	2.5 A	Hopper Dump Door, Thermo Sentry™ and Air Flow Solenoids
CB-6	15 A	Lights
FU-1	40 A	Accessory (Hydraulic Pump) Motor
FU-2	80 A	Propelling Motor

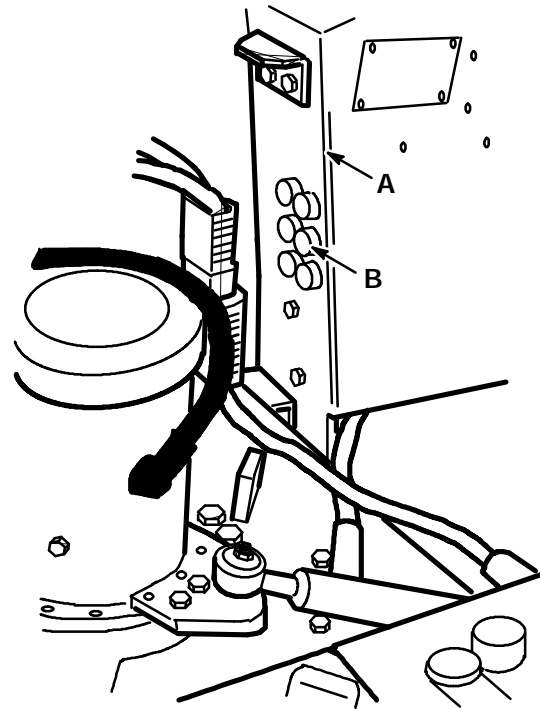

**CIRCUIT BREAKERS**

03367

- A. Instrument Panel Bracket**
- B. Circuit Breakers**

**HOPPER SUPPORT BAR**

The hopper support bar is located on the right side lift arm. The support bar holds the hopper in a raised position to allow work to be done under the hopper. Do not rely on the machine hydraulic system to keep the hopper raised.

**⚠ WARNING: Falling Hopper. Engage Hopper Support Bar Before Working Under Hopper.**

**MACHINE OPERATION****NORMAL SWEEPING OPERATION**

A normal sweeping operation consists of seven typical operations: pre-start checklist, starting machine, sweeping, dumping hopper, post operation checklist - motor operating, stopping machine, and post operation checklist - motor stopped.

The *PRE-START CHECKLIST* lists things to check before starting the machine.

*TO START MACHINE* lists the steps required to start the machine.

*TO SWEEP* lists things to keep in mind before and during the sweeping operation.

*TO DUMP HOPPER* lists the steps required to dump the hopper.

*POST OPERATION CHECKLIST - MOTOR OPERATING* lists things to check before stopping the machine motor.

*TO STOP MACHINE* lists the steps required to stop the machine.

*POST OPERATION CHECKLIST - MOTOR STOPPED* lists things to check after stopping the machine motor.

**PRE-START CHECKLIST**

Check under machine for leak spots.

Check brakes and controls for proper operation.

Check service records to determine service requirements.

**TO START MACHINE**

*NOTE: Before starting machine, perform the pre-start checks.*

1. The machine operator must be in the operator's seat with the directional pedal in the "neutral" position and with a foot on the brake pedal or with the parking brake set.

**FOR SAFETY: Before Starting Machine, Make Sure All Safety Devices Are In Place And Operate Properly.**

2. Turn the key-operated on-off switch key to the "ON" position.
3. Release the machine parking brake.
4. Drive the machine to the area to be swept.

**TO SWEEP**

Plan the sweeping in advance. Try to arrange long runs with minimum stopping and starting. Sweep debris from very narrow aisles into main aisles ahead of time. Do an entire floor or section at one time. Overlap the brush paths.

Pick up oversize debris before sweeping. Flatten or remove bulky cartons from aisles before sweeping. Pick up pieces of wire, twine, string, etc., which could become entangled in brush or brush plugs. Place large debris in hopper through hopper inspection door.

Avoid turning the steering wheel too sharply when the machine is in motion. The machine is very responsive to the movement of the steering wheel. Avoid sudden turns, except in emergencies.

Sweep as straight a path as possible. Avoid bumping into posts or scraping the sides of the machine.

1. Place the accessory switch in the "ON" position.
2. Move the vacuum lever to the "Normal Sweeping" position to sweep dry debris, or "Wet Sweeping" position to sweep wet debris.
3. Push the main brush lever forward and to the left, then release the lever to lower the main brush.
4. Move the side brush lever into the "Down" position.
5. Push the side brush and hopper lever into the "ON" position.
6. Press and hold the hopper door switch in the "OPEN" position.
7. Sweep as required.

## TO DUMP HOPPER

1. Push the main brush lever into the "UP" position.
2. Pull the side brush lever into the "Raised" position.
3. Move the vacuum lever to the "Filter Shaker" position for 20 seconds to shake the dust filter.
4. Slowly drive the machine up to the dump site or dumpster.
5. Press and hold the hopper door switch in the "CLOSE" position.
6. Pull the side brush and hopper lever to the "LIFT" position, then into the "HOLD" position when the hopper reaches the desired dump height.
7. Press and hold the hopper door switch in the "OPEN" position to dump the hopper.
8. Press and hold the hopper door switch in the "CLOSE" position to close the hopper door.
9. Slowly back the machine away from the dump site or dumpster.
10. Push the side brush and hopper lever to the "LOWER" position to lower the hopper.
11. Press and hold the hopper door switch in the "OPEN" position to open the hopper door.

## POST OPERATION CHECKLIST - MOTOR OPERATING

Check the brush patterns for width and evenness.

## TO STOP MACHINE

1. Return the directional pedal to the "neutral" position. Apply the brake.
2. Push the main brush lever into the "UP" position.
3. Pull the side brush lever back into the "Raised" position.
4. Pull the side brush and hopper lever into the "LOWER" position to stop the side brush.
5. Place the accessory switch in the "OFF" position.
6. Set the machine parking brake.
7. Turn the key-operated on-off switch key to the "OFF" position. Remove the key from the switch.

**FOR SAFETY: Before Leaving Or Servicing Machine; Stop On Level Surface, Set Parking Brake, Turn Off Machine And Remove Key.**

## POST OPERATION CHECKLIST - MOTOR STOPPED

Check the skirts for damage, wear, and adjustment.

Check for wire or string tangled on the brushes.

Check for leaks.

## OPERATION

### TO ENGAGE HOPPER SUPPORT BAR

**⚠ WARNING: Falling Hopper. Engage Hopper Support Bar Before Working Under Hopper.**

1. Set the machine parking brake.

**FOR SAFETY: Before Leaving Or Servicing Machine; Stop On Level Surface, Set Parking Brake, Turn Off Machine And Remove Key.**

2. Raise the hopper.
3. Position the hopper support bar on the bar stand.

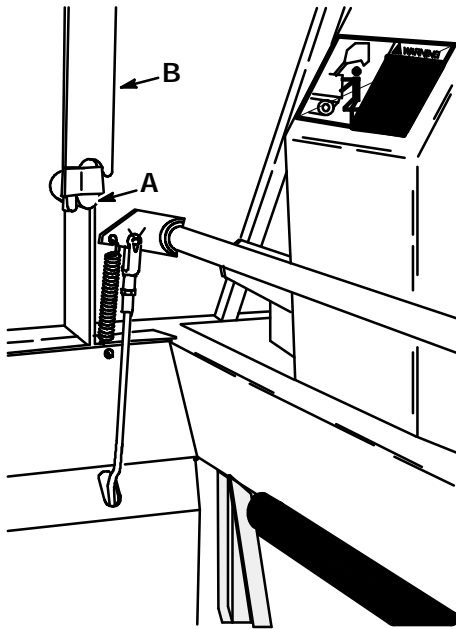

HOPPER SUPPORT BAR STAND

- A. Bar Stand
- B. Support Bar

03369

4. Slowly lower the hopper so the bar is secure.

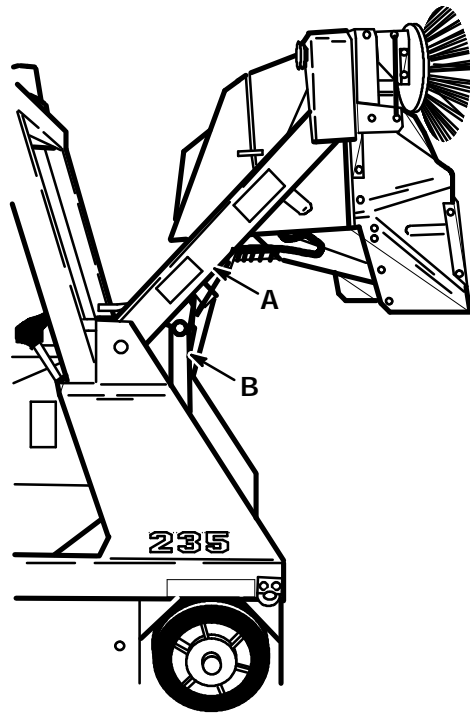

ENGAGED HOPPER SUPPORT BAR

- A. Lift Arm
- B. Support Bar

03370

### TO DISENGAGE HOPPER SUPPORT BAR

1. Raise the hopper.
2. Place the support bar in its storage position.
3. Lower the hopper.

### OPERATION ON GRADES

Drive the machine slowly on grades. Use the brake pedal to control machine speed.

**FOR SAFETY: When Using Machine, Go Slow On Grades And Slippery Surfaces.**

The maximum rated climb and descent angle is 10°.

## MACHINE TROUBLESHOOTING

Problem	Cause	Remedy
Excessive dusting	Dust skirts and seals worn, damaged, not adjusted properly	Replace or adjust skirts or seals
	Dust filter clogged	Shake and clean or replace filter
	Vacuum hose damaged	Replace vacuum hose
	Vacuum fan failure	Belt loose, broken or off sheave
Poor sweeping performance	Brush bristles worn	Replace brushes
	Brushes not adjusted properly	Adjust brushes
	Debris caught in brush drive mechanism	Free mechanism of debris
	Main brush drive failure	Belt loose, broken or off sheave
	Side brush drive failure	See <i>HYDRAULIC SYSTEM TROUBLESHOOTING</i> : Side brush turns slowly or not at all
	Hopper not adjusted properly	Adjust hopper floor clearance
	Hopper dump door closed	Open dump door
	Hopper full	Empty hopper
	Hopper floor skirts worn, damaged	Replace skirts
Machine moves with jerky motion - like running out of gas	Low battery charge	Charge batteries
Machine will not travel	Low battery charge	Charge batteries
	Parking brake set	Release parking brake
	Fuse blown	Replace fuse
	Controller overheated	Allow controller to cool
	Controller failure	See <i>PROPELLING SYSTEM TROUBLESHOOTING</i>

**TRANSPORTING MACHINE****PUSHING OR TOWING MACHINE**

The machine may be slowly pushed from the front or rear, pushing on the bumper or the machine frame.

The machine may be slowly towed from the front. Use care when attaching towing cables or chains to avoid damaging the machine.

**MACHINE JACKING**

The machine may be jacked up for service at the designated locations. Use a jack of adequate capacity and good working condition. Always stop the machine on a flat, level surface and block the tires before jacking the machine up.

The front jacking locations are on the flat bottom edge of the machine frame next to the front tires. The rear jacking location is the middle flat bottom edge of the rear bumper.

**TO JACK UP MACHINE**

1. Empty and lower the debris hopper.
2. Stop the motor and set the machine parking brake.

**FOR SAFETY: Before Leaving Or Servicing Machine; Stop On Level Surface, Set Parking Brake, Turn Off Machine And Remove Key.**

3. Block the tires, which are not being jacked up, in order to secure the machine position.

**FOR SAFETY: When Servicing Machine, Block Machine Tires Before Jacking Machine Up.**

4. Use a jack of adequate capacity to raise the machine. Jack up the machine only at the designated locations.

**FOR SAFETY: When Servicing Machine, Use Hoist Or Jack Of Adequate Capacity To Lift Machine.**

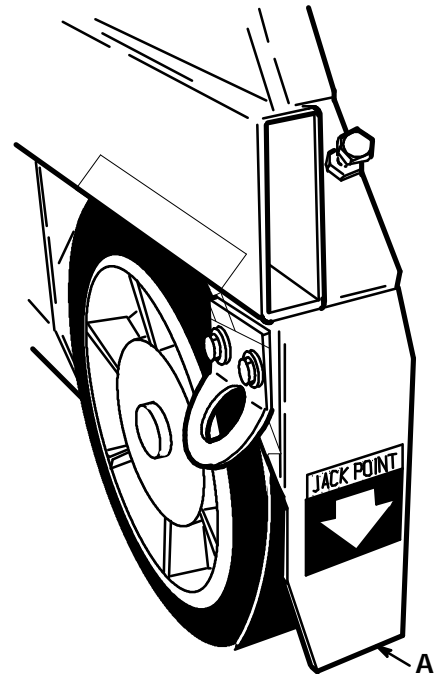

03372

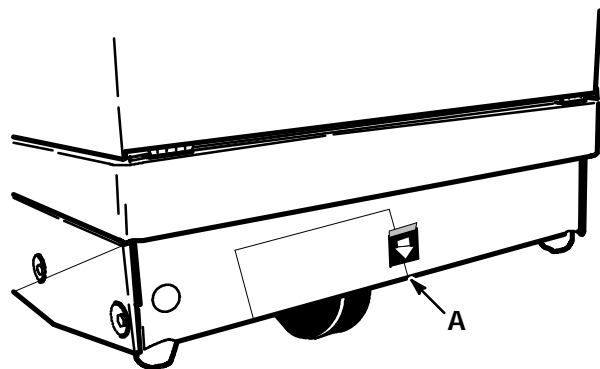
**FRONT JACKING LOCATION****A. Jacking Location**

03373

**REAR JACKING LOCATION****A. Jacking Location**

5. Block machine up with jack stands or similar devices in the designated locations to secure the machine.

**FOR SAFETY: When Servicing Machine, Jack Machine Up At Designated Locations Only. Block Machine Up With Jack Stands.**

6. Lower the machine onto the jack stands.
7. Check to make sure the machine is secure.
8. Service the machine as required.
9. When finished servicing the machine, raise the machine off the jack stands.
10. Remove the jack stands from under the machine.
11. Lower the machine.
12. Remove the blocks from the tires.

### MACHINE TIE-DOWNS

The machine may be tied down at each corner of the main frame using the tie-down brackets supplied in the tie-down kit.

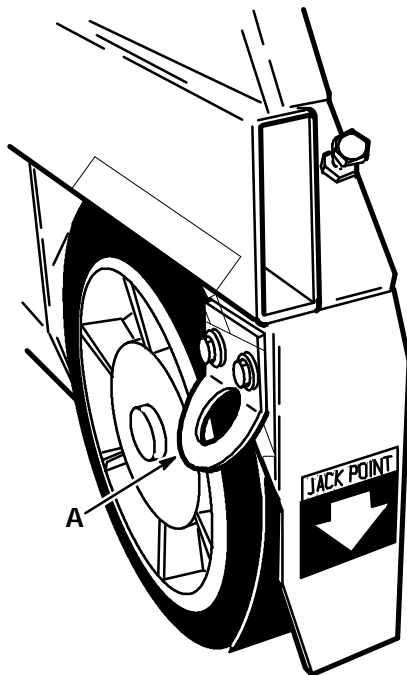

03372

#### FRONT TIE-DOWN LOCATION

##### A. Tie-Down Bracket

When transporting the machine on a trailer or in a truck, be sure to set the machine parking brake and block the machine tires to prevent the machine from rolling.

**MACHINE STORAGE****STORING MACHINE**

When storing the machine for extended periods of time, the following procedures must be followed to lessen the chance of rust, sludge, or other undesirable deposits from forming.

1. Empty the debris hopper.
2. Raise the main brush and side brush.
3. Park the machine in a cool, dry area.
4. Remove or charge the batteries for four hours once every three months.



**SECTION 3**

**CONTENTS**

	Page		Page
RECOMMENDED FIRST 50-HOUR MACHINE		DEBRIS HOPPER AND DUST FILTER ...	3-27
INSPECTION .....	3-3	DEBRIS HOPPER .....	3-27
MAINTENANCE CHART .....	3-4	TO CHECK AND ADJUST	
LUBRICATION .....	3-6	HOPPER FLOOR CLEARANCE .	3-27
GEARBOX .....	3-6	THERMO SENTRY™ .....	3-27
REAR WHEEL SUPPORT BEARING ..	3-6	TO CHECK THE	
SIDE BRUSH LEVER PIVOT .....	3-6	THERMO SENTRY™ .....	3-27
STEERING LINKAGE .....	3-7	HOPPER DUST FILTER .....	3-28
HYDRAULICS .....	3-8	TO REMOVE AND REPLACE	
HYDRAULIC FLUID .....	3-8	HOPPER DUST FILTER .....	3-29
HYDRAULIC FLUID RESERVOIR .....	3-8	BRUSHES .....	3-30
HYDRAULIC FILTER .....	3-9	MAIN BRUSH .....	3-30
TO REPLACE FILTER ELEMENT ..	3-9	TO REMOVE MAIN BRUSH .....	3-30
HYDRAULIC FLUID LEAKS .....	3-9	TO INSTALL MAIN BRUSH .....	3-30
HYDRAULIC SCHEMATIC .....	3-10	TO CHECK AND ADJUST MAIN	
HYDRAULIC SYSTEM		BRUSH PATTERN .....	3-30
TROUBLESHOOTING .....	3-11	SIDE BRUSH .....	3-32
HYDRAULIC COMPONENTS		TO REMOVE SIDE BRUSH .....	3-32
TROUBLESHOOTING .....	3-12	TO INSTALL SIDE BRUSH .....	3-32
ELECTRICAL SYSTEM .....	3-13	SKIRTS AND SEALS .....	3-33
BATTERIES .....	3-13	BRUSH SKIRTS .....	3-33
BATTERY CHARGING .....	3-14	TO REPLACE AND ADJUST	
TO CHARGE BATTERIES .....	3-14	BRUSH SKIRTS .....	3-33
ELECTRIC MOTORS .....	3-16	REAR SKIRTS .....	3-33
PROPELLING SYSTEM		TO REPLACE AND ADJUST	
TROUBLESHOOTING .....	3-17	REAR SKIRTS .....	3-33
PROPELLING CIRCUIT .....	3-18	HOPPER LIP SKIRT .....	3-34
TO ADJUST "NEUTRAL" POSITION	3-18	TO REPLACE HOPPER LIP SKIRT .	3-34
ELECTRICAL SCHEMATIC (For machine		DUST SEALS .....	3-34
below serial number 002205) ...	3-19	TO REPLACE DUST SEALS .....	3-34
ELECTRICAL SCHEMATIC (For machines		HOPPER DUMP DOOR SEAL .....	3-35
from serial number 002205		TO REPLACE HOPPER DUMP	
to 002310) .....	3-20	DOOR SEAL .....	3-35
ELECTRICAL SCHEMATIC (For machines		VACUUM FAN SEAL .....	3-36
serial number 002311 and above)	3-21	FILTER COVER SEAL .....	3-36
ELECTRICAL SCHEMATIC, AUXILIARY		BRAKES AND TIRES .....	3-37
SIDE BRUSH (For machines serial		BRAKES .....	3-37
number 002311 and above) .....	3-22	TIRES .....	3-37
BEELTS AND CHAINS .....	3-23	REAR WHEEL .....	3-37
HYDRAULIC PUMP BELT .....	3-23		
TO REPLACE AND ADJUST			
HYDRAULIC PUMP BELT .....	3-23		
VACUUM FAN BELT .....	3-24		
TO REPLACE AND ADJUST			
VACUUM FAN BELT .....	3-24		
MAIN BRUSH BELT .....	3-25		
TO REPLACE MAIN BRUSH BELT .	3-25		
TAPER LOCK BUSHINGS .....	3-26		
TO REMOVE TAPER			
LOCK BUSHING .....	3-26		
TO INSTALL TAPER			
LOCK BUSHING .....	3-26		
STATIC DRAG CHAIN .....	3-26		



**RECOMMENDED FIRST 50-HOUR MACHINE INSPECTION**

After the first 50 hours of operation, the following procedures are recommended:

1. Check the floor skirts to floor clearance. See *SKIRTS AND SEALS*.
2. Check the side brush and main brush patterns. See *BRUSHES*.
3. Change the gearbox gear lubricant and the drain and fill/level plug seals.
4. Tighten the wheel nuts.
5. Replace the hydraulic fluid filter element.
6. Torque the rear wheel nuts in a star pattern to 122 to 150 Nm (90 to 110 ft lb). See *REAR WHEEL*.
7. Perform all 50-hour interval lubrication and maintenance procedures listed in the *MAINTENANCE CHART*.

**MAINTENANCE CHART**

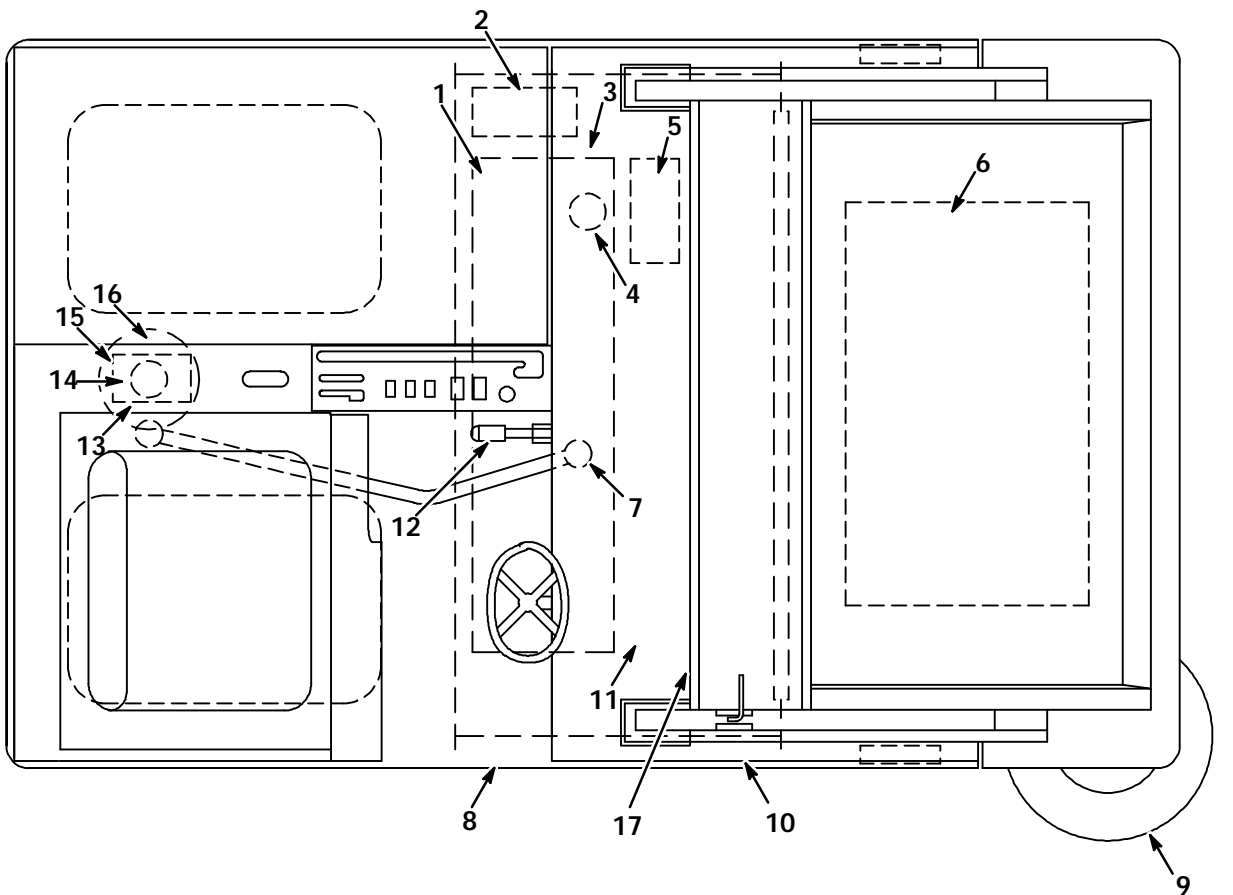

03374

Interval	Key	Description	Procedure	Lubricant	No. of Service Points
Daily	8	Brush and rear skirts	Check for damage and wear	-	4
	17	Hopper lip skirt	Check for damage and wear	-	1
	1	Main brush	Check for damage and wear	-	1
	9	Side brush	Check for damage and wear	-	1
50 Hours	1	Main brush	Rotate end-for-end	-	1
100 Hours	1	Dust Seals	Check for damage and wear	-	6
	6	Dust filter	Clean or replace	-	1
	5	Hydraulic reservoir	Check fluid level	HYDO	1
	6	Thermo Sentry™	Test	-	1
	14	Rear tire	Inspect for wear	-	1
	10	Front tires	Inspect for wear	-	2
	15	Gearbox	Check lubricant level	GL	1

**MAINTENANCE**

Interval	Key	Description	Procedure	Lubricant	No. of Service Points
200 Hours	2	Vacuum fan belt	Check condition and tension	-	1
	3	Hydraulic pump belt	Check condition and tension	-	1
	11	Side brush lever pivot	Lubricate	SPL	1
	12	Parking brake	Check adjustment	-	1
	13	Rear wheel support bearing	Lubricate	SPL	2
	7	Steering linkage	Lubricate	SPL	2
400 Hours	5	Hydraulic fluid reservoir	Change hydraulic fluid	HYDO	1
	4	Hydraulic fluid filter	Change filter element		1
800 Hours	13	Rear wheel	Torque wheel nuts	-	1
1000 Hours	15	Gearbox	Change gear lubricant	GL	1
	3	Accessory motor	Check brushes	-	1
	16	Propelling motor	Check brushes	-	1

GL - SAE 90 Gear weight lubricant

HYDO - TENNANT or approved hydraulic fluid

SPL - Special lubricant, Lubriplate EMB grease (TENNANT part number 01433-1)

*NOTE: More frequent intervals may be required in extremely dusty conditions.*

**LUBRICATION**

**GEARBOX**

The gearbox transfers power from the propelling motor to the rear wheel, and is lubricated with SAE 90 weight gear lubricant. Check the lubricant level after every 100 hours of operation. Change the gear lubricant and the drain and fill/level plug seals after the first 50 hours of operation and then after every 1000 hours of operation.

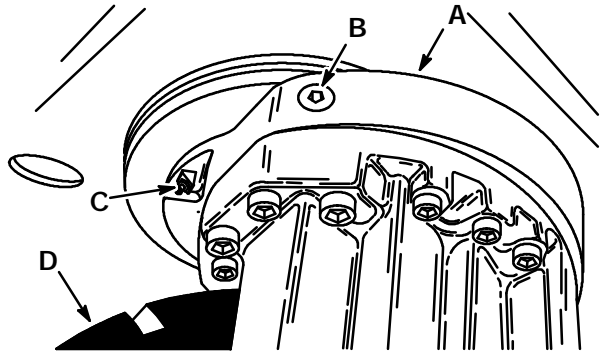

**GEARBOX**

05934

- A. Gearbox
- B. Fill/level Plug
- C. Support Grease Fitting
- D. Rear Wheel

**SIDE BRUSH LEVER PIVOT**

The side brush lever pivot allows the side brush lever to move freely. Lubricate the pivot with Lubriplate EMB grease (TENNANT part number 01433-1) after every 200 hours of operation.

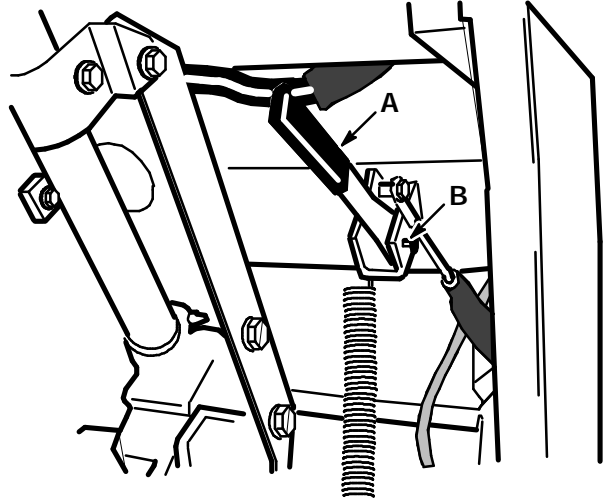

**SIDE BRUSH LEVER PIVOT**

03396

- A. Side Brush Lever
- B. Pivot

**REAR WHEEL SUPPORT BEARING**

The rear wheel support bearing allows the gearbox and rear wheel assembly to rotate freely. Raise the machine so the rear wheel is off the ground. Fill one grease fitting with Lubriplate EMB grease (Tennant Part No. 01433-1) while rotating the gearbox from stop to stop. Fill the second grease fitting while rotating the gearbox back to the original position. The bearing cavity is full when grease comes out of the fitting or out of the top seal. Apply the lubricant after every 200 hours of operation or after steam cleaning the propelling gearbox area.

**FOR SAFETY: When Servicing Machine, Block Machine Tires Before Jacking Machine Up. Jack Machine Up At Designated Locations Only. Block The Machine Up With Jack Stands.**

**STEERING LINKAGE**

The steering linkage controls machine steering. A grease fitting is located on each of the two linkage ball joints for lubrication. The linkage should be lubricated by applying Lubriplate EMB grease (TENNANT part number 01433-1) to the grease fittings after every 200 hours of operation.

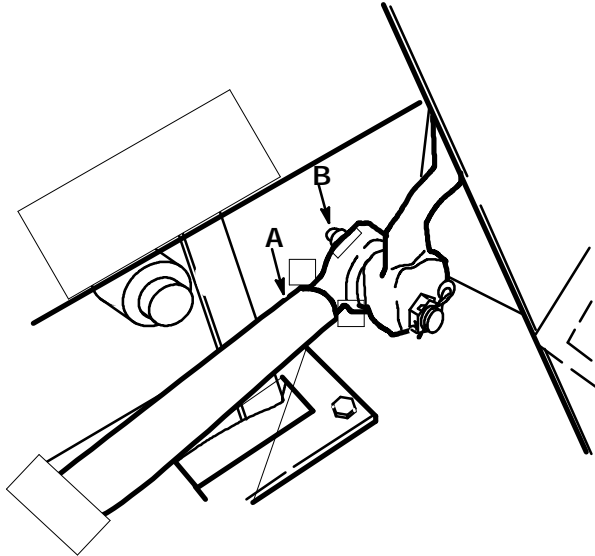
**FRONT STEERING LINK**

03394

- A. Steering Link**
- B. Grease Fitting**

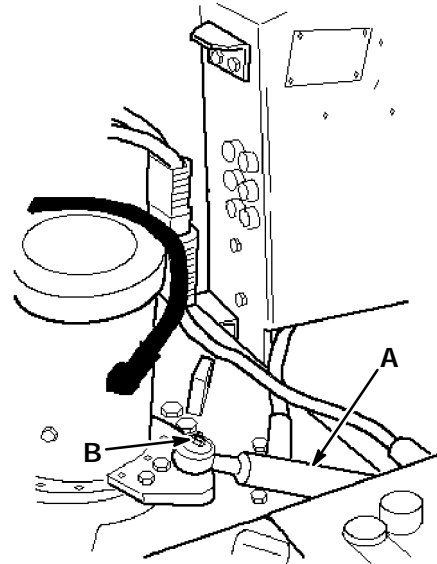
**REAR STEERING LINK**

03367

- A. Steering Link**
- B. Grease Fitting**

**HYDRAULICS**

**HYDRAULIC FLUID**

The quality and condition of the hydraulic fluid play a very important role in how well the machine operates. TENNANT's hydraulic fluid is specially selected to meet the needs of TENNANT machines.

TENNANT's hydraulic fluids provide a longer life for the hydraulic components. There is one recommended fluid.

TENNANT part no.	Fluid Weight
65870	5-20W

If a locally-available hydraulic fluid is used, make sure the specifications match TENNANT hydraulic fluid specifications. Using substitute fluids can cause premature failure of hydraulic components.

European marketed machines are filled with locally available hydraulic fluids. Check the label on the hydraulic fluid reservoir.

**ATTENTION! Hydraulic components depend on system hydraulic fluid for internal lubrication. Malfunctions, accelerated wear, and damage will result if dirt or other contaminants enter the hydraulic system.**

**HYDRAULIC FLUID RESERVOIR**

Hydraulic fluid is stored in the hydraulic fluid reservoir. It holds 1 gal (3.8 L) of hydraulic fluid. The reservoir is mounted on the back of the hydraulic pump.

The fluid level is checked by opening the fill cap with the hopper in the sweeping position. The reservoir is full when the fluid level is between the marks on the dipstick.

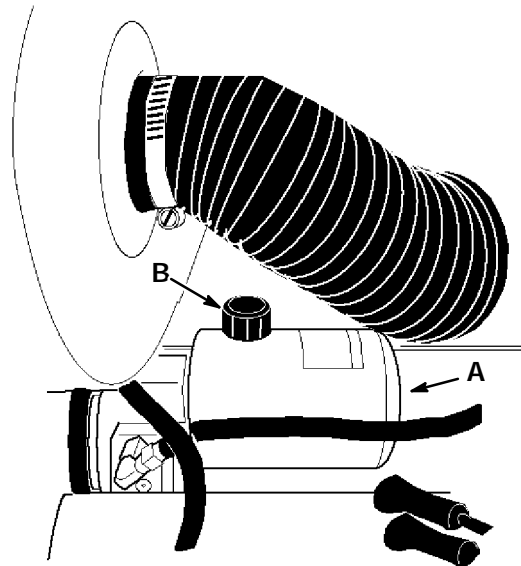

**HYDRAULIC PUMP**

03379

- A. Pump**
- B. Fill Cap**

Check the hydraulic fluid level after every 100 hours of operation. Change the hydraulic fluid after every 400 hours of operation. To remove the hydraulic fluid, insert a hand suction device through the fill opening. Do not overfill the hydraulic fluid reservoir. Hydraulic fluid expands as it heats to its normal operating temperature. Always allow for expansion when filling the reservoir.



**HYDRAULIC FILTER**

The hydraulic fluid filter keeps the machine hydraulic system clean to a level of 10 microns. The hydraulic fluid filter is located next to the vacuum fan.

Replace the hydraulic fluid filter element after the first 50 hours of operation and then after every 400 hours of operation.

**TO REPLACE FILTER ELEMENT**

1. Stop the motor and set the machine parking brake.

**FOR SAFETY: Before Leaving Or Servicing Machine; Stop On Level Surface, Set Parking Brake, Turn Off Machine And Remove Key.**

2. Open the seat support.

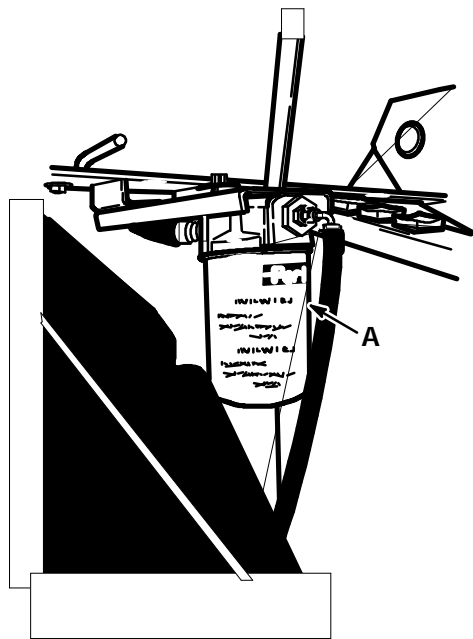

**HYDRAULIC FLUID FILTER**

**A. Filter Element**

3. Unthread and discard the hydraulic fluid filter element.
4. Apply a thin coat of hydraulic fluid to the seal of the new hydraulic fluid filter element.

5. Thread and hand tighten the new hydraulic fluid filter element on the filter head.
6. Close the seat support.
7. Operate the machine and check for leaks. Correct any leaks found.
8. Check the hydraulic fluid reservoir level and fill as required.

**HYDRAULIC FLUID LEAKS**

Fluid escaping from a very small hole can be almost invisible. Use a piece of cardboard or wood, rather than hands, to search for suspected leaks.

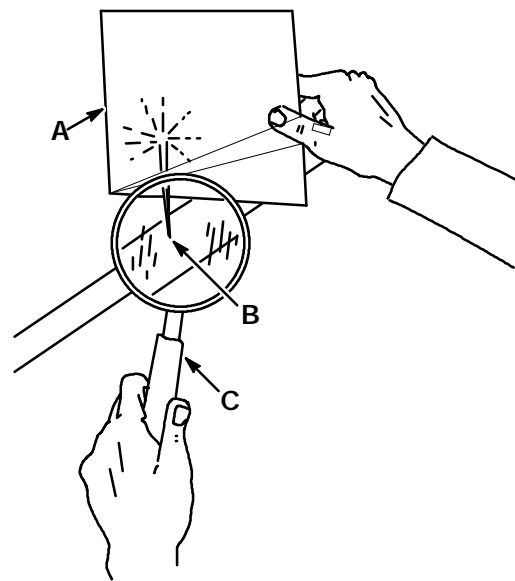

**HYDRAULIC PINHOLE LEAK**

- A. Cardboard**
- B. Pinhole Leak**
- C. Magnifying Glass**

If injured by escaping hydraulic fluid, see a doctor at once. Serious infection or reaction can develop if proper medical treatment is not administered immediately.

**FOR SAFETY: When Servicing Machine, Use Cardboard To Locate Leaking Hydraulic Fluid Under Pressure.**

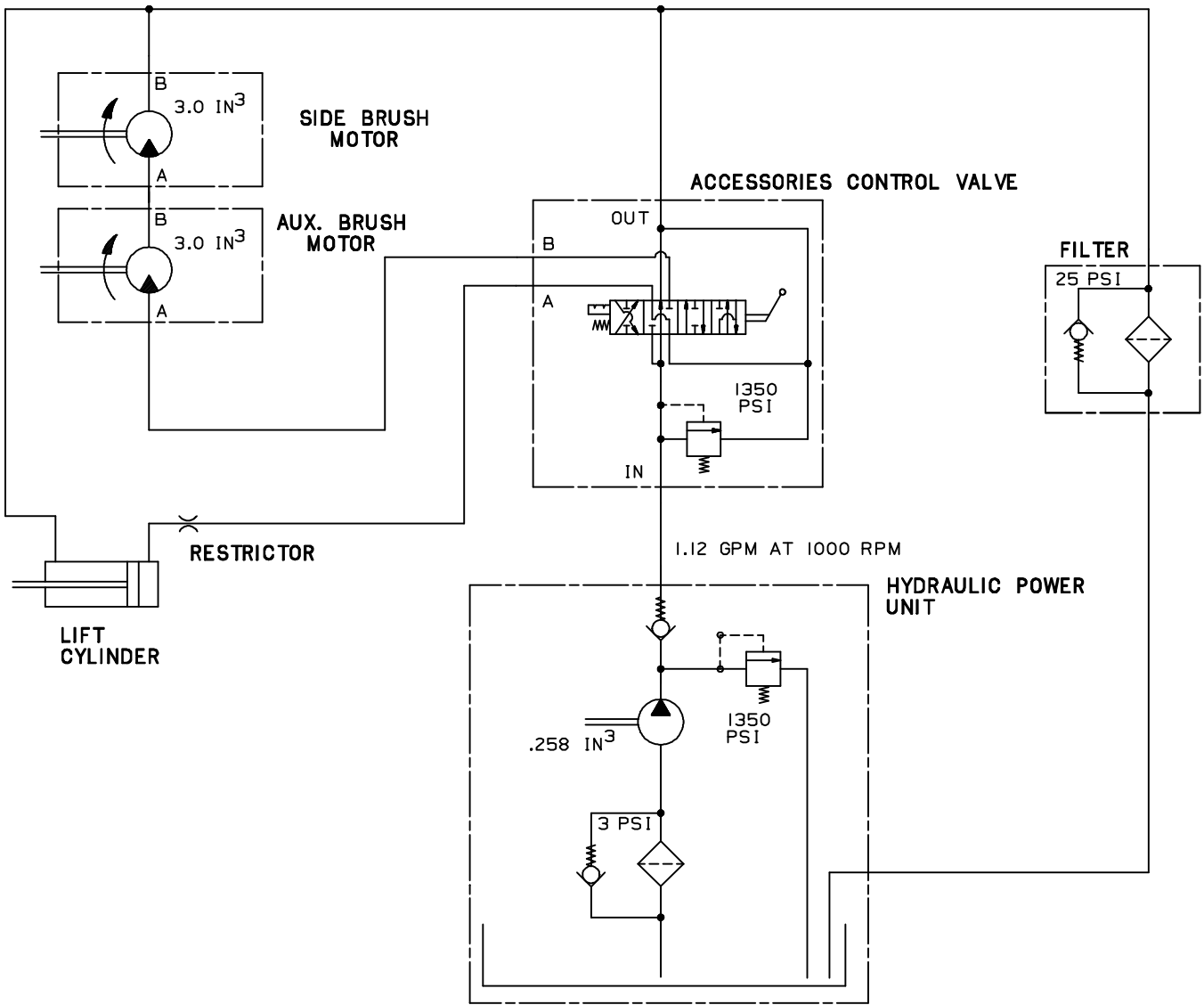

**HYDRAULIC SCHEMATIC**

03380

**HYDRAULIC SYSTEM TROUBLESHOOTING**

Problem	Cause	Remedy
Side brush turns slowly or not at all	Hydraulic control valve failure	See <i>HYDRAULIC COMPONENTS TROUBLESHOOTING</i> : Hydraulic control valve failure
	Hydraulic motor failure	See <i>HYDRAULIC COMPONENTS TROUBLESHOOTING</i> : Hydraulic motor failure
	Relief valve in control valve sticking	Clean or replace relief valve
	Gear pump failure	See <i>HYDRAULIC COMPONENTS TROUBLESHOOTING</i> : Hydraulic gear pump failure
Hopper will not lift	Hydraulic control valve failure	See <i>HYDRAULIC COMPONENTS TROUBLESHOOTING</i> : Hydraulic control valve failure
	Hydraulic orifice at lift cylinder plugged	Replace orifice
	Lift cylinder failure	See <i>HYDRAULIC COMPONENTS TROUBLESHOOTING</i> : Hydraulic cylinder failure
	Gear pump failure	See <i>HYDRAULIC COMPONENTS TROUBLESHOOTING</i> : Hydraulic gear pump failure
	Hopper overloaded	Empty hopper
	Lift arms binding	Replace and/or adjust lift arm linkage
Hopper will not lower	Lift cylinder failure	See <i>HYDRAULIC COMPONENTS TROUBLESHOOTING</i> : Hydraulic cylinder failure
	Lift arms binding	Replace and/or adjust lift arm linkage
	Hydraulic orifice at lift cylinder plugged	Replace orifice

**HYDRAULIC COMPONENTS TROUBLESHOOTING**

Problem	Cause	Remedy
Hydraulic cylinder failure	Piston seals leaking	Install seal kit
	Barrel worn or rod bent	Replace cylinder rod
Hydraulic control valve failure	Valve seals leaking	Install seal kit
	Relief valve stuck open (leaking)	Clean or replace relief valve
Hydraulic motor failure	Motor leaking	Install seal kit
	Drive link failure	Replace drive link
	Gerotor worn	Replace gerotor set
	Output shaft failure	Replace output shaft and bearings
Hydraulic gear pump failure	Pump leaking	Install seal kit
	Gear set failure	Replace gear set
	Shaft failure	Replace gear set

**ELECTRICAL SYSTEM**

**BATTERIES**

The standard six 6-volt batteries or the optional two 18-volt batteries provide all of the energy used by the machine. The standard batteries are rated at 295 A/h at a 6-hour rate. The heavy duty batteries are rated at 306 A/h at a 4-hour rate. They require regular maintenance to keep them operating their best.

Do not allow batteries to remain in discharged condition for any length of time.

Do not operate machine if batteries are in poor condition or only 25% of the charge left.

Periodically clean the top surface and the terminals and check for loose connections. Use a strong solution of baking soda and water. Brush the solution sparingly over the battery top, terminals, and cable clamps. Do not allow any baking soda solution to enter the battery. Use a wire brush to clean the terminal posts and the cable connectors. After cleaning, apply a coating of clear petroleum jelly to the terminals and the cable connectors. Keep the tops of the batteries clean and dry.

Keep all metallic objects off the top of the batteries, as they may cause a short circuit. Replace worn or damaged wires.

Check the electrolyte level in each battery cell before and after charging the batteries. Never add acid to batteries, only water. Do not overfill. Keep vent plugs firmly in place at all times, except when adding water or taking hydrometer readings.

**FOR SAFETY: When Servicing Machine, Avoid Contact With Battery Acid.**

Use a hydrometer to check the electrolyte specific gravity.

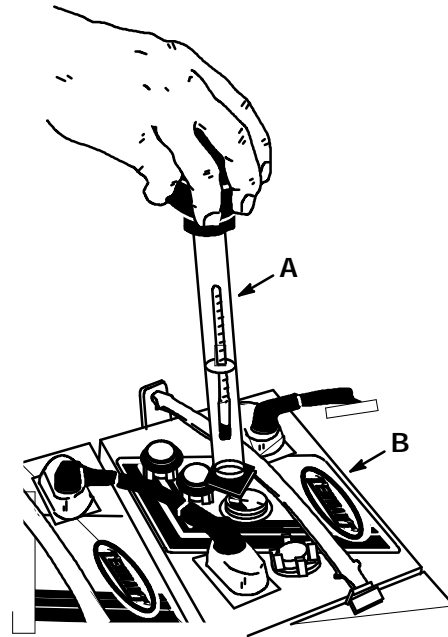

**CHECKING BATTERY SPECIFIC GRAVITY** 01373

- A. Hydrometer**
- B. Battery**

If one or more battery cells tests lower than the other battery cells, (0.050 or more) the cell is damaged, shorted, or is about to fail.

*NOTE: Do not take readings immediately after adding water--if the water and acid are not thoroughly mixed, the readings may not be accurate. Check the hydrometer readings against this chart:*

SPECIFIC GRAVITY at 80° F (27° C)	BATTERY CONDITION
1.265	100% charged
1.225	75% charged
1.190	50% charged
1.155	25% charged
1.120	Discharged

*NOTE: If the readings are taken when the battery electrolyte is any temperature other than 80° F (27° C), the reading must be temperature corrected.*

## MAINTENANCE

To determine the corrected specific gravity reading when the temperature of the battery electrolyte is other than 80° F (27° C):

Add to the specific gravity reading 0.004, 4 points, for each 10° F (6° C) above 80° F (27° C).

Subtract from the specific gravity reading 0.004, 4 points, for each 10° F (6° C) below 80° F (27° C).

### BATTERY CHARGING

The machine batteries are specially made for this type of application. They are unique in that they hold their power for long periods of time, but they can only be recharged a certain number of times. To get the most life from the batteries, charge them when 25% of their power is left.

Eleven to fourteen hours is generally enough time to charge a discharged set of standard, 295 A/h batteries. Twelve to fifteen hours is generally enough time to charge a set of heavy duty, 306 A/h batteries. If the batteries are not fully discharged, set the timer for a period of time that is proportionally less than what is required for a fully discharged set of batteries, ie: half discharged heavy duty batteries need seven to eight hours of charging time.

Do not expose the battery charger to water. Do not touch uninsulated battery terminals or unnecessarily expose any portion of your body to the batteries when making electrical connections.

### TO CHARGE BATTERIES

1. Stop the machine on a flat, dry surface next to the charger, and set the machine parking brake.

**FOR SAFETY: Before Leaving Or Servicing Machine; Stop On Level Surface, Set Parking Brake, Turn Off Machine And Remove Key.**

2. Place the key switch in the "OFF" position.
3. Open the seat support.

**⚠ WARNING: Batteries Emit Hydrogen Gas. Explosion Or Fire Can Result. Keep Sparks And Open Flame Away. Keep Covers Open When Charging.**

4. Check the electrolyte level in the batteries. Before charging, add just enough distilled water to cover the plates. Then, after charging is completed, add enough water to bring the electrolyte up to the indicator mark. If the water level is topped off before charging, normal expansion of the electrolyte may cause an overflow, resulting in loss of acid balance and acid damage to the machine area around the batteries.

*NOTE: Machines with heavy duty batteries must have the vacuum fan exhaust deflector removed to gain access to the battery caps.*

5. Replace battery caps and leave them in place while charging.
6. Unplug the machine connector from the batteries connector.

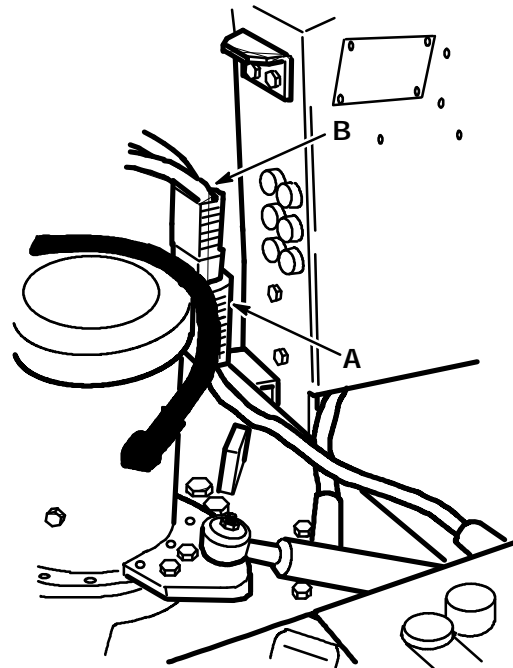

**BATTERIES CONNECTOR**

- A. Batteries Connector**  
**B. Machine Connector**

03367

7. Plug the charger connector into the battery connector mounted on the machine.

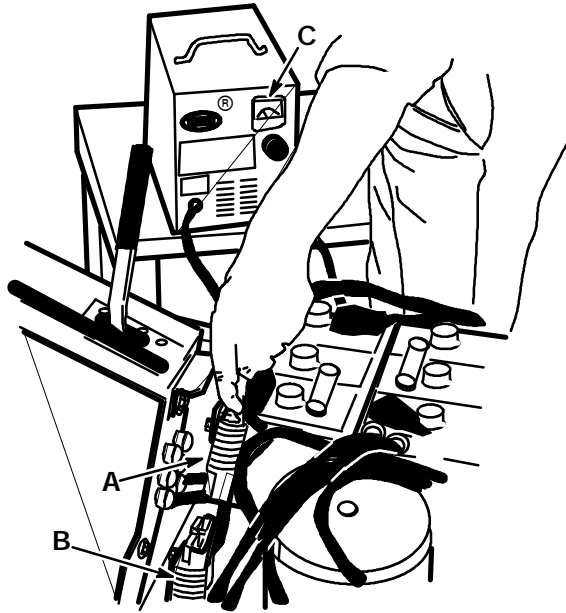

**CHARGING BATTERIES**

03381

- A. Charger Connector
- B. Battery Connector
- C. Charger Gauge

8. Timer equipped charger: turn the battery charger knob to the number of hours you wish to charge the batteries. The charger gauge will indicate the charger is operating.

The batteries will be fully charged when the timer reads "off" or the battery specific gravity is 1.265.

*NOTE: Make sure the battery charger has been turned off before unplugging the charger from the battery connector on the machine.*

**Automatic chargers:** Plug the charger connector into the battery connector. The charge will start automatically in three to five seconds and turn off when the batteries are fully charged.

**Smart Chargers:** Plug the charger connector into the battery connector. The charger will go through a self diagnostic check. All the indicator lamps on the charger panel will flash showing the diagnostic check is in progress.

*NOTE: If the red no charge indicator lamp lights when the charger is plugged into a wall outlet, the charger can not charge the battery, meaning there is something wrong with the battery.*

When the lamps stop flashing, the *red incomplete battery status indicator lamp* lights. After a short delay, the *yellow charger on indicator lamp* lights showing the charger has turned on.

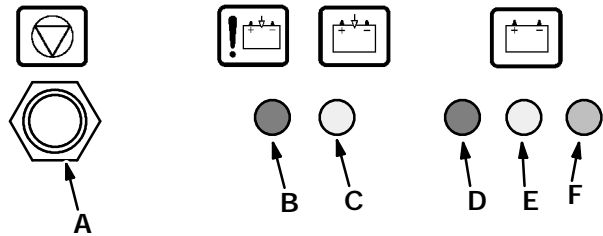

**CHARGER PANEL**

06898

- A. Interrupt Switch
- B. Red No Charge Indicator Lamp
- C. Yellow Charger On Indicator Lamp
- D. Red Incomplete Battery Status Indicator Lamp
- E. Yellow 80% Charge Indicator Lamp
- F. Green Complete Charge Indicator Lamp

As the battery charges, the *red incomplete battery status indicator lamp* goes out and the *yellow 80% charge indicator lamp* lights.

Finally the *yellow 80% charge indicator lamp* goes out and the green complete charge indicator lamp lights showing the battery is completely charged. After a short time, the *yellow charger on indicator lamp* goes out showing the charger has turned off.

The *green complete charge indicator lamp* will remain on until the charger is unplugged from the wall outlet.

*NOTE: If the charge cycle has to be stopped, press the interrupt switch **while** unplugging the charger from the wall outlet.*

## MAINTENANCE

9. Unplug the charger connector from the battery connector.
10. Reconnect the machine connector to the battery connector.
11. Check the electrolyte level of the batteries; it should be up to the indicator mark.

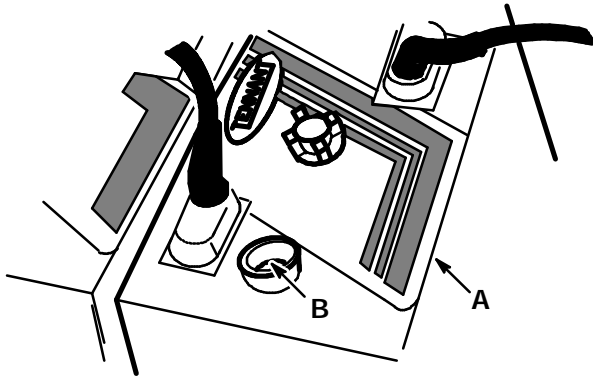

00879

### CHECKING BATTERY ELECTROLYTE LEVEL

- A. Battery
- B. Electrolyte Indicator Ring

12. Lower the seat support.

### ELECTRIC MOTORS

The electric propelling motor and the accessory motor are repairable.

Blow out the dust and inspect the motor brushes in the motors after every 1000 hours of operation.

If the brushes are broken, cracked, chipped, or have been worn to less than 0.62 in (15 mm) in length on the short side on the propelling motor, or 0.38 in (10 mm) on the accessory motor, replace them. Remember to always replace brushes in sets.

If the commutator is worn or rough, the motor armature should be removed and serviced.



**PROPELLING SYSTEM TROUBLESHOOTING**

Problem	Cause	Verification/Remedy
No propelling	Low battery charge	Charge batteries
	Loose or broken wires	Locate and fix or replace wires
	Controller overheated (for machines below serial number 002311)	Thermal switch tripped - allow controller time to cool down
	Blown fuse (80A)	Replace fuse
	Seat shroud switch failure	Replace seat shroud switch
	Key-operated on-off switch failure	Replace on-off switch
	Motor or gearbox failure	Check motor and gearbox for binding. Check motor for failure
	M3 contactor failure	Replace M3 contactor
Vehicle accelerates without pedal movement	Directional pedal not at "neutral" position	See <i>PROPELLING CIRCUIT: TO ADJUST "NEUTRAL" POSITION</i>
Full speed only	Damaged wires, short circuits, crossed wires	Check visually for damage Check controller for dirt or metal chips causing short circuit
Machine will not reach full speed	Batteries run down	Charge batteries
Vibration or roughness when braking	M1 and M2 contactor failure	Replace M1 and M2 contactor
Weak and uneven braking forward and reverse	M1 and M2 contactor failure	Replace M1 and M2 contactor
Very strong braking	Armature and field wires interchanged	Correct wire installation
Contactors close, little or no power. High pitched whistle	Loose connections	Locate and fix or replace wires
	Short circuit in motor	Test for short circuit. Repair or replace
	Armature and field wires interchanged	Correct wire installation
Contactors close, machine moves to full speed but lacks power	Loose connections	Locate and fix or replace wires
Forward speed only	Contactor failure	Replace contactor
Reverse speed only	Contactor failure	Replace contactor
Sporadic operation	Low battery charge	Charge batteries
	Controller overheated (for machines below serial number 002311)	Thermal switch tripped - allow controller time to cool down
	Water in circuit	Disconnect batteries and dry affected areas

*NOTE: For more detailed troubleshooting information for qualified personnel, order the 235E Propelling System Troubleshooting Manual, TENNANT part number MM182.*

## PROPELLING CIRCUIT

The propelling circuit is made up of contactors and a transistorized controller. They control the forward and reverse speed of the machine. They are located in the controller panel. The circuit is not user serviceable - only trained service personnel should be allowed to work on it. Do not steam clean or spray the panel with water as it may damage the electrical system.

**FOR SAFETY: When Servicing Machine, Disconnect Battery Connections Before Working On Machine.**

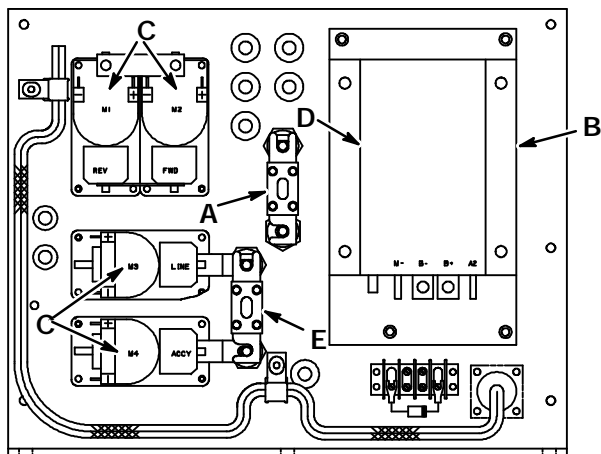

**CONTROLLER PANEL**

03630

- A. 80 A Fuse (Main)
- B. Controller
- C. Contactor
- D. Logic Board
- E. 40 A Fuse (Accessory)

## TO ADJUST "NEUTRAL" POSITION

Loosen the set screws on the accelerator shaft and allow the pedal to center. First tighten the set screw on the round part of the shaft; then the set screw on the flat part of the shaft.

Then set reverse limited speed, by adjusting the stop screw near the heel portion of the directional pedal. The machine should travel 3 mph (5 km/h) in reverse.

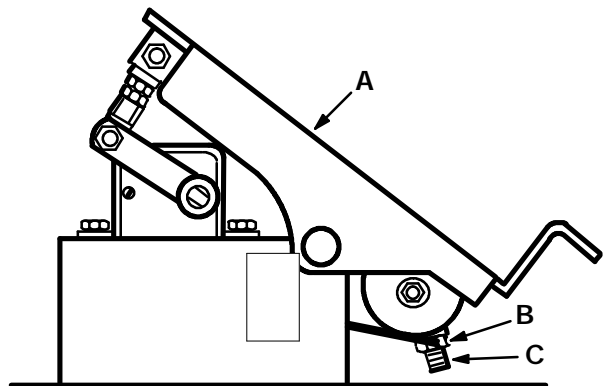

**DIRECTIONAL PEDAL**

04238

- A. Directional Pedal
- B. Jam Nut
- C. Stop Screw

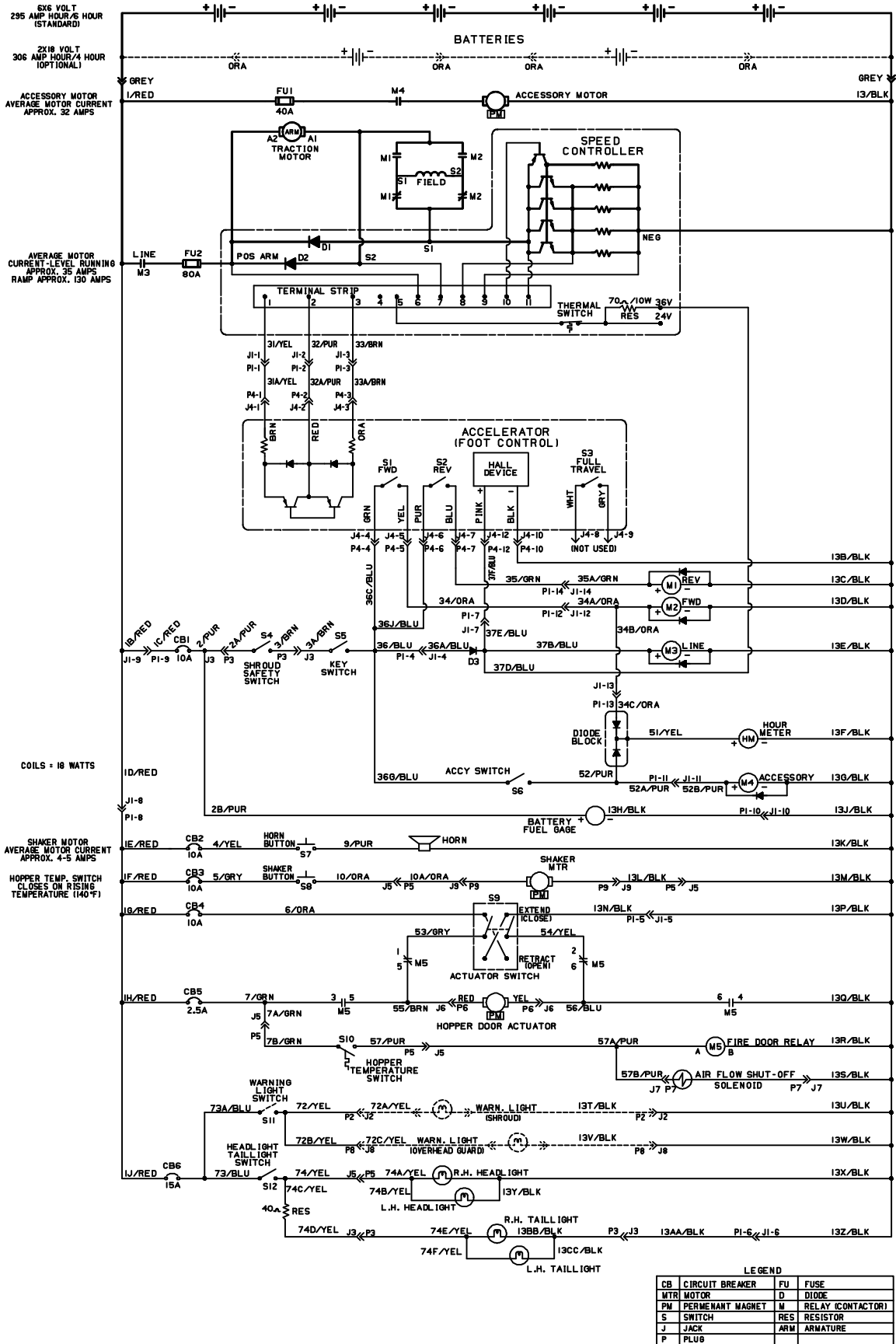

**ELECTRICAL SCHEMATIC**  
(For machine below serial number 002205)

03382

# MAINTENANCE

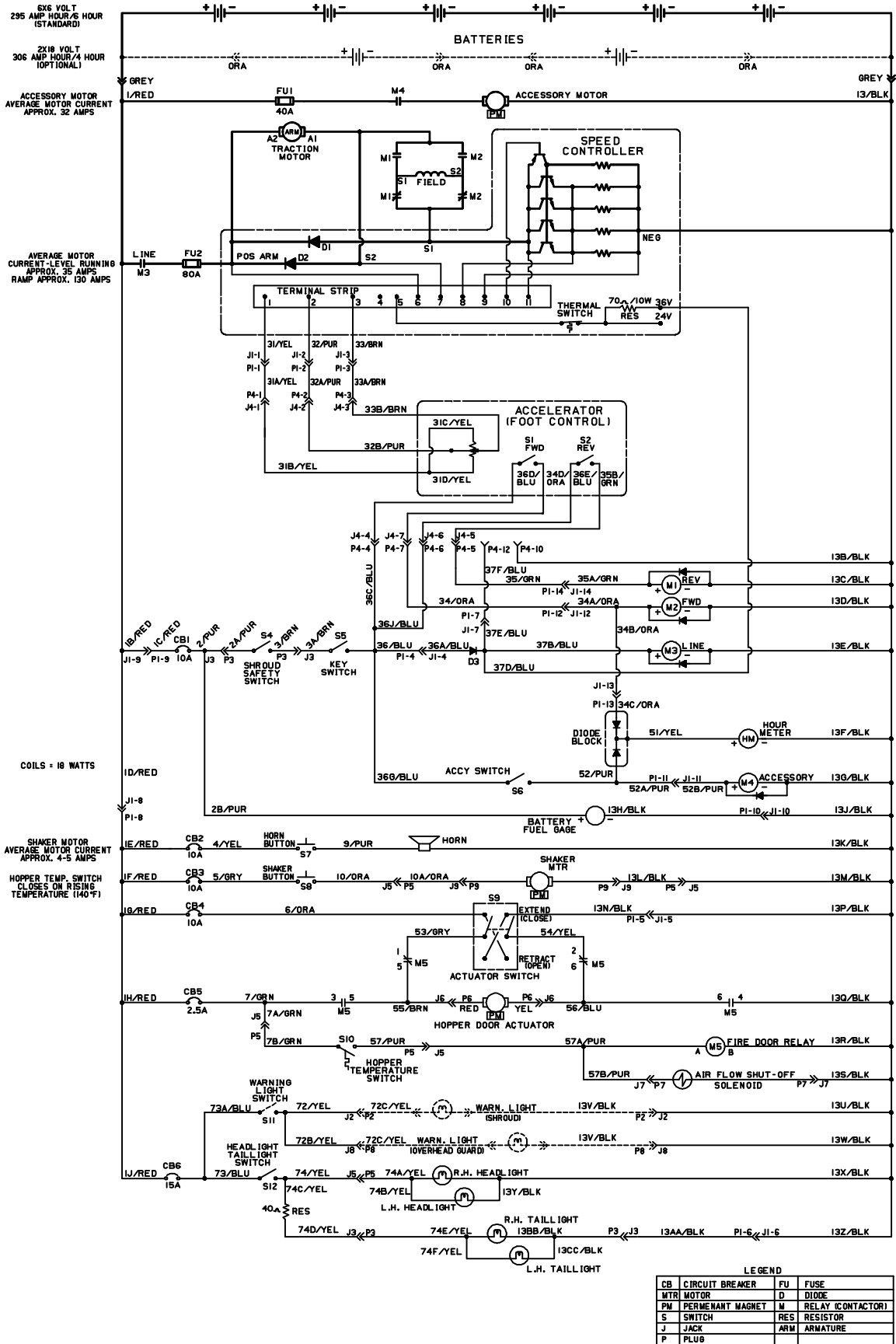

**ELECTRICAL SCHEMATIC**  
 (For machines from serial number 002205 to 002310)

03382

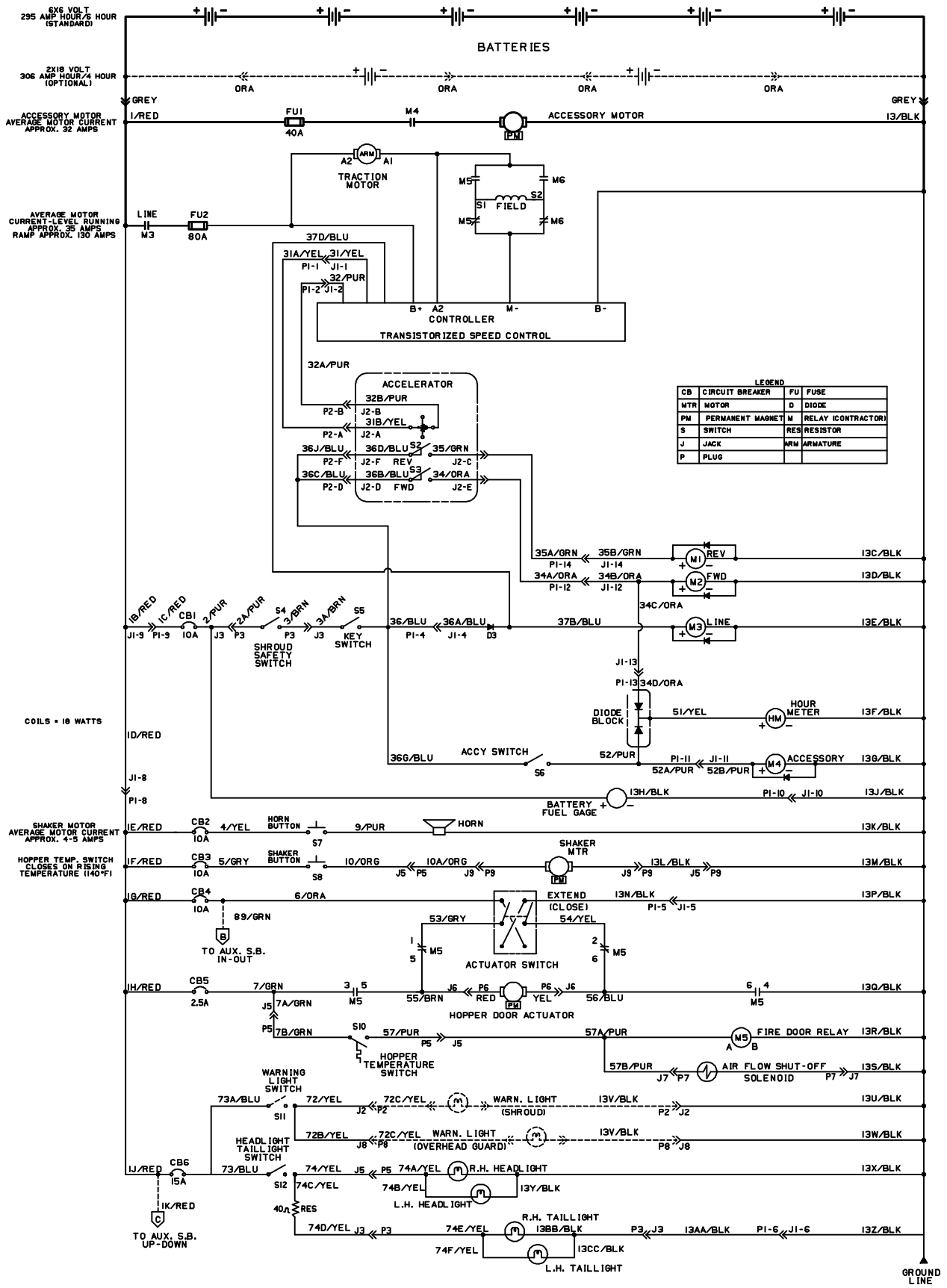

**ELECTRICAL SCHEMATIC**  
(For machines serial number 002311 and above)

03382

GROUND  
LINE

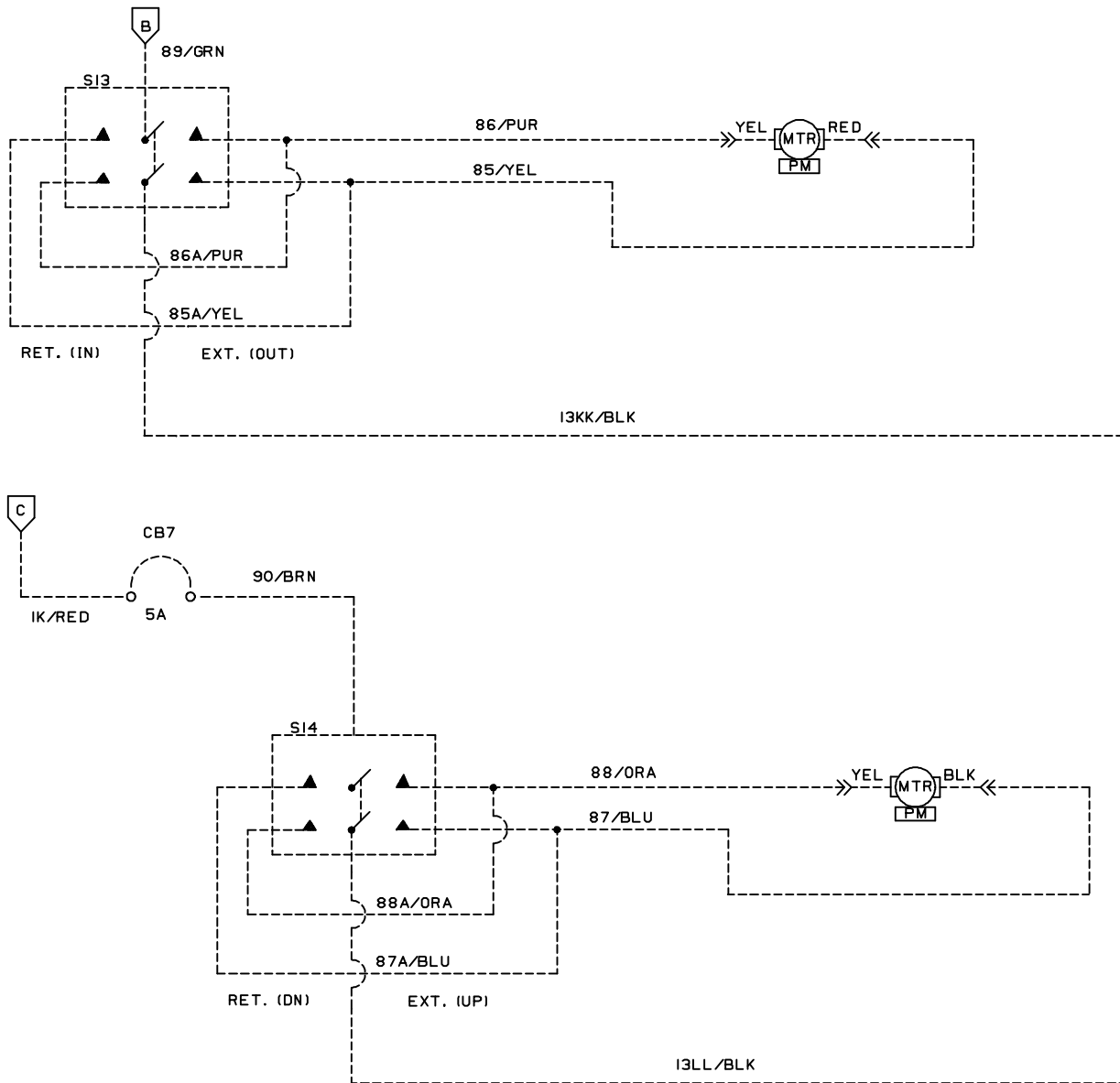

03382

**ELECTRICAL SCHEMATIC, AUXILIARY SIDE BRUSH**  
(For machines serial number 002311 and above)

**BELTS AND CHAINS**

**HYDRAULIC PUMP BELT**

The hydraulic pump belt transfers power from the motor sheave to the hydraulic pump. Check the belt condition and tension after every 200 hours of operation. The belt is properly tensioned when the belt deflects 0.25 in (6 mm) from a force of 6 lb (3 kg) applied at belt midpoint.

**TO REPLACE AND ADJUST HYDRAULIC PUMP BELT**

1. Stop the motor and set the parking brake.

**FOR SAFETY: Before Leaving Or Servicing Machine; Stop On Level Surface, Set Parking Brake, Turn Off Machine And Remove Key.**

2. Raise the main brush.
3. Open the seat support.
4. Remove the vacuum fan belt guard.
5. Remove the left side access door.
6. Hold the main brush belt idler spring arm back and remove the main brush belt.

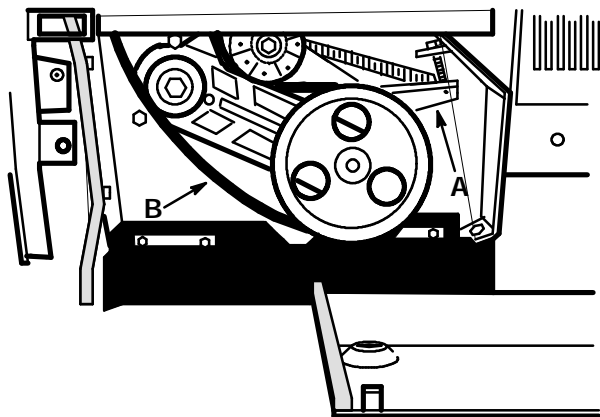

**IDLER SPRING**

- A. Idler Spring Arm
- B. Main Brush Belt

7. Loosen the motor adjustment and mounting bolts.

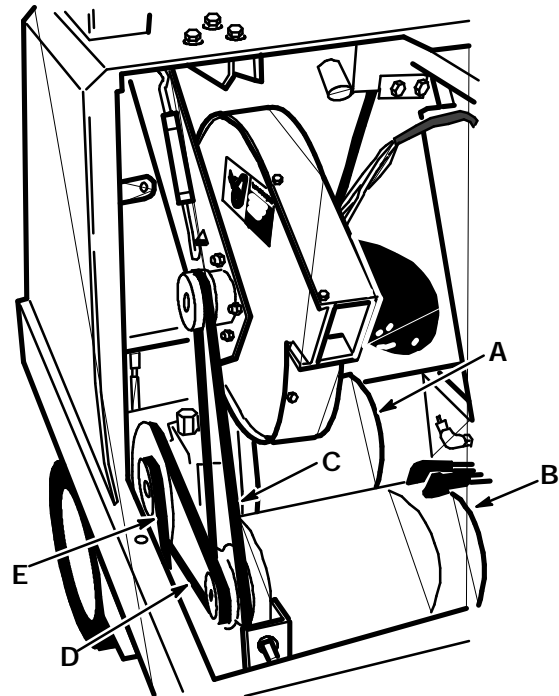

**MOTOR**

- A. Hydraulic Pump
- B. Motor
- C. Vacuum Fan Belt
- D. Hydraulic Pump Belt
- E. Main Brush Belt

8. Slide the motor forward keeping the sheaves aligned and remove and replace the hydraulic pump belt.
9. Pull the motor back and snug the mounting bolts.

- Check belt tension. If it meets specification, tighten the bolts. If not, retension the belt.

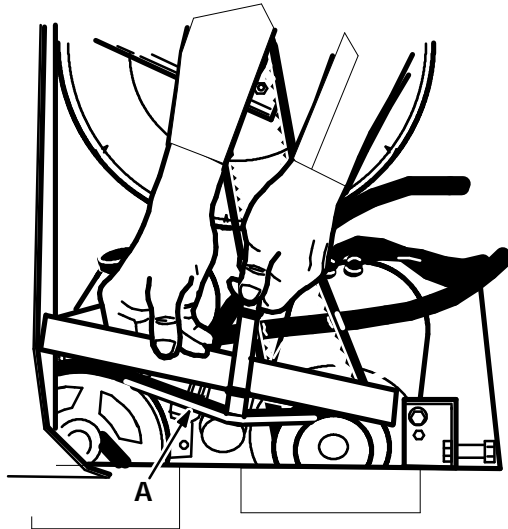

**CHECKING BELT TENSION**

04236

### A. Hydraulic Pump Belt

- Hold the main brush belt idler spring arm back and position the main brush belt on the belt sheaves.
- Replace the left side access door.
- Replace the belt guard.
- Lower the seat support.

### VACUUM FAN BELT

The vacuum fan belt transfers power from the motor sheave to the vacuum fan. Check the belt condition and tension after every 200 hours of operation. The belt is properly tensioned when the belt deflects 0.25 in (6 mm) from a force of 6 lb (3 kg) applied at belt midpoint.

#### TO REPLACE AND ADJUST VACUUM FAN BELT

- Stop the motor and set the parking brake.

**FOR SAFETY: Before Leaving Or Servicing Machine; Stop On Level Surface, Set Parking Brake, Turn Off Machine And Remove Key.**

- Open the seat support.

- Remove the belt guard.

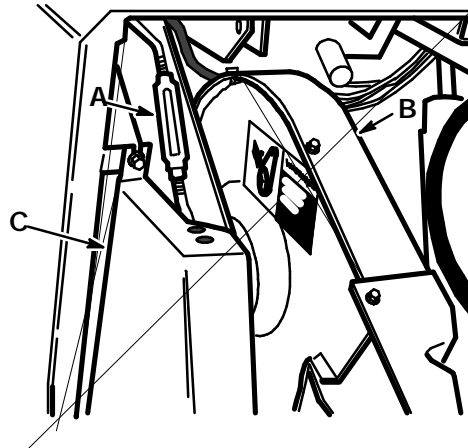

**VACUUM FAN BELT GUARD**

03385

- A. Turnbuckle
- B. Vacuum Fan
- C. Belt Guard

- Loosen the vacuum fan belt tension by turning the belt turnbuckle.
- Loosen the motor adjustment and mounting bolts.

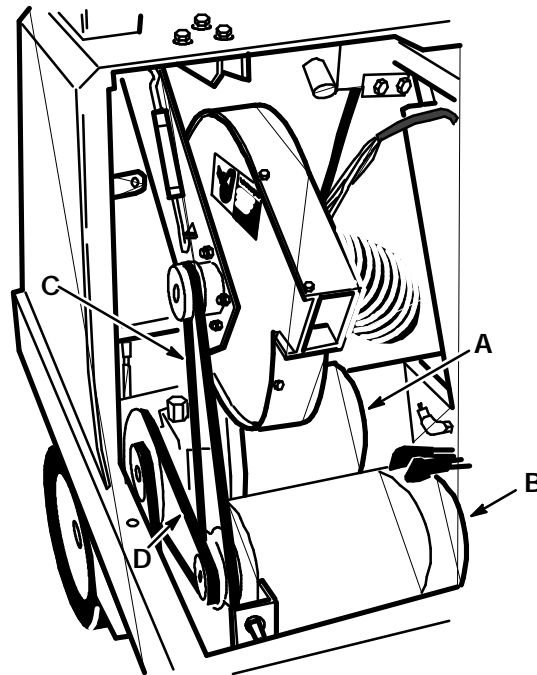

**VACUUM FAN BELT**

03391

- A. Hydraulic Pump
- B. Motor
- C. Vacuum Fan Belt
- D. Hydraulic Pump Belt



6. Slide the motor forward to loosen the hydraulic pump belt.
7. Replace the existing vacuum fan belt with a new belt.
8. Tighten the hydraulic pump belt as described in *TO REPLACE AND ADJUST HYDRAULIC PUMP BELT*.
9. Turn the turnbuckle to tighten the vacuum fan belt to specification.

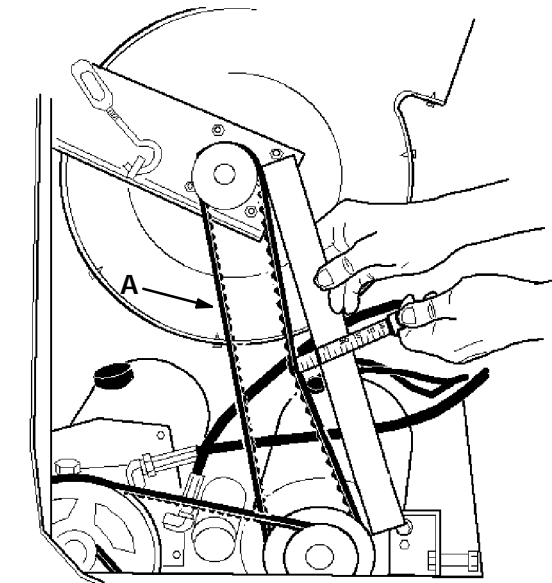

**CHECKING BELT TENSION**

04237

**A. Vacuum Fan Belt**

10. Replace the belt guard.
11. Lower the seat support.

**MAIN BRUSH BELT**

The main brush belt transfers power from the jackshaft to the main brush. The belt is tensioned by a belt idler spring. A stop bolt is used to remove tension from the belt when the main brush is raised.

**TO REPLACE MAIN BRUSH BELT**

1. Stop the motor and set the parking brake.

**FOR SAFETY: Before Leaving Or Servicing Machine; Stop On Level Surface, Set Parking Brake, Turn Off Machine And Remove Key.**

2. Raise the main brush.
3. Open the seat support.
4. Remove the left side access door and vacuum fan belt guard.
5. Hold the idler spring arm back and remove the belt.

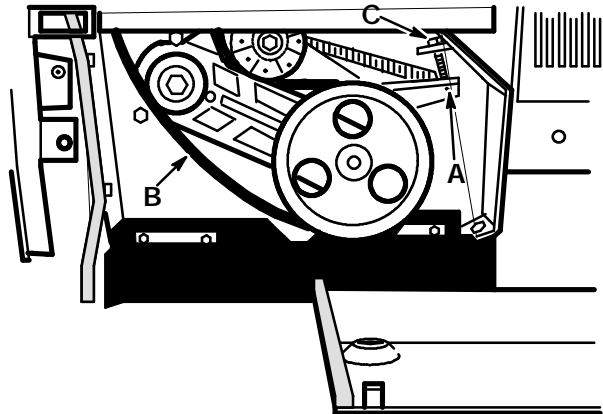

03377

**MAIN BRUSH BELT**

- A. Idler Spring Arm**
- B. Main Brush Belt**
- C. Stop Bolt**

6. Hold the idler spring arm back and position the new belt on the belt sheaves.
7. Replace the vacuum fan belt guard.
8. Lower the seat support.
9. Start the machine and lower the main brush. Then raise the brush. The brush should stop turning within seconds of being raised. If the belt is too tight, the brush will continue to turn. If the belt is too loose, it may jump off the idler or driven sheave. Turn the belt stop bolt to adjust belt tension.
10. Replace the left side access door.
11. Lower the seat support.

## TAPER LOCK BUSHINGS

A taper lock bushing is used to secure the sheave on the hydraulic pump shaft.

### TO REMOVE TAPER LOCK BUSHING

1. Remove all set screws.

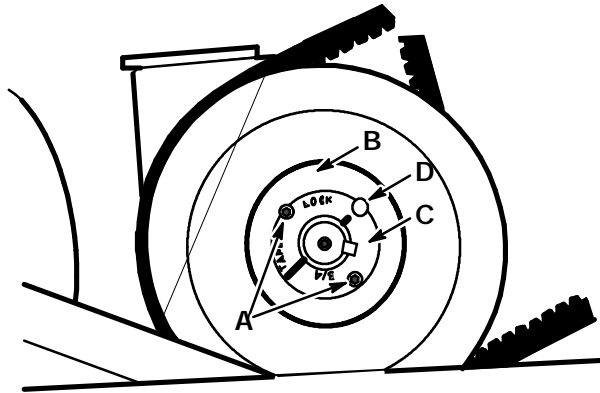

TAPER LOCK BUSHING

03506

- A. Set Screw
- B. Hub
- C. Bushing
- D. Threaded Hole

2. Insert set screw into threaded hole of bushing.
3. Tighten the set screw to loosen bushing from shaft.

### TO INSTALL TAPER LOCK BUSHING

1. Clean shaft, bore and outside of bushing and hub bore of all oil, lacquer, and dirt.
2. Insert bushing into hub; be aware of sheave alignment. Match hole pattern, not threaded holes. Each hole will be threaded on one side only.

3. Oil set screws. Thread them into the half threaded holes.
4. Alternately tighten the set screws to 55 in lb (6 Nm).
5. Using a block, sleeve, or drift, hammer the end of the bushing. Do not hammer bushing directly.
6. Repeat steps 4 and 5 until torque wrench reading is the same after hammering as before.
7. Fill all open holes with grease.

## STATIC DRAG CHAIN

The static drag chain prevents the buildup of static electricity in the machine. The chain is attached to the rear skirt retaining strip.

Make sure that the chain is making contact with the floor at all times.

**DEBRIS HOPPER AND DUST FILTER**

**DEBRIS HOPPER**

The debris hopper collects debris swept by the machine and should be dumped after every work shift. The hopper floor clearance should be checked and adjusted periodically.

**TO CHECK AND ADJUST HOPPER FLOOR CLEARANCE**

1. Empty the hopper and park the machine on a smooth, level surface.
2. Lower the hopper.
3. Stop the motor and set the parking brake.

**FOR SAFETY: Before Leaving Or Servicing Machine; Stop On Level Surface, Set Parking Brake, Turn Off Machine And Remove Key.**

4. Check the hopper bumper to machine frame match. They should line up within 0.12 in (5 mm). Adjust by repositioning the stop bolts on the frame above the front wheels.

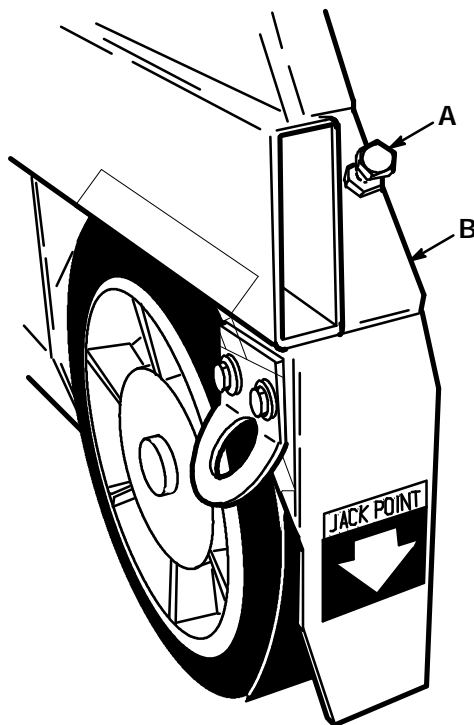

**BUMPER STOP BOLT**

03372

- A. Stop Bolt
- B. Frame

5. Check the distance between the floor and the bottom metal edge of the hopper. The floor clearance should be 1 in (25 mm) across the width of the machine. To adjust the hopper floor clearance, unlatch and remove the filter cover and adjust the hopper stop bolt.

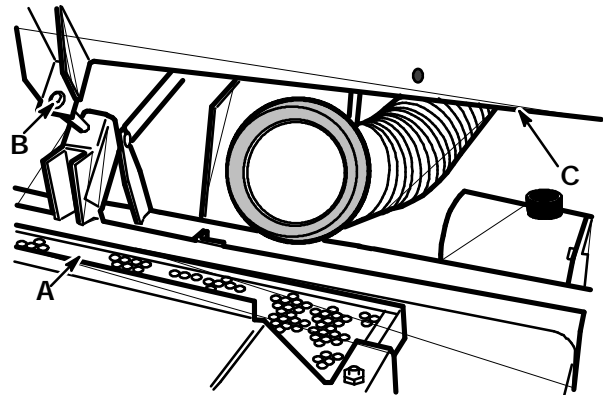

**HOPPER STOP BOLT**

03387

- A. Hopper
- B. Stop Bolt
- C. Lintel

6. Replace the filter cover and check the hopper cover seal. It should be slightly compressed.

**THERMO SENTRY™**

The Thermo Sentry™ stops the machine vacuum and closes the hopper door in case of a fire in the hopper. Check to make sure the Thermo Sentry™ is operating properly after every 100 hours of operation.

**TO CHECK THE THERMO SENTRY™**

1. Stop the motor and set the parking brake.

**FOR SAFETY: Before Leaving Or Servicing Machine; Stop On Level Surface, Set Parking Brake, Turn Off Machine And Remove Key.**

2. Unlatch the filter cover latches and remove the filter cover.

3. Place the vacuum lever in the "Normal Sweeping" position.
4. Apply heat to the bottom of the Thermo Sentry™ with a match or lighter. The vacuum lever should move to the "Wet Sweeping" position, the hopper door should close, and their circuit breakers should trip. If they do not, the system is malfunctioning.

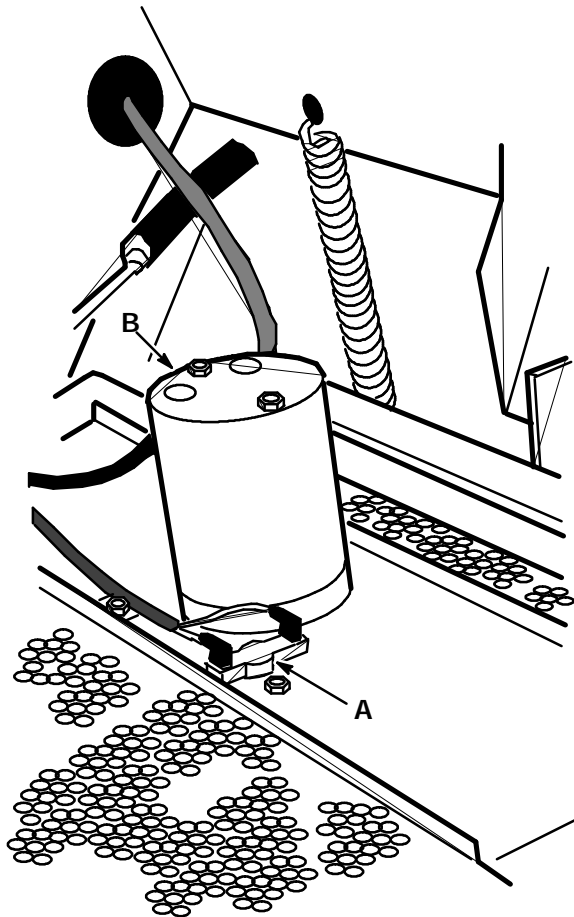

THERMO SENTRY™

03393

- A. Thermo Sentry™
- B. Shaker Motor

5. Replace the filter cover and check the hopper cover seal. It should be slightly compressed.
6. After the Thermo Sentry™ has cooled, reset the circuit breakers behind the control panel.

## HOPPER DUST FILTER

The hopper dust filter filters the air which is drawn up from the main brush compartment by the vacuum fan. It is located inside the dust filter compartment. Shake the excess dust from the filter daily. Inspect and clean or replace the dust filter after every 100 hours of operation.

To clean the dust filter use one of the following methods:

- TAPPING - Tap the filter gently on a flat surface with the dirty side down. Do not damage the edges of the filter element or the filter will not seat properly in the filter frame.
- AIR - Blow compressed air, 35 psi (240 kPa) maximum, through the dust filter opposite the direction of the arrows. This may be done with the filter in the machine. Always wear eye protection when using compressed air.

**FOR SAFETY: When Servicing Machine, Wear Eye And Ear Protection When Using Pressurized Air Or Water.**

- WATER - Soak the dust filter in a water and mild detergent solution. Rinse the dust filter until it is clean. The maximum water pressure allowable is 40 psi (275 kPa). Air dry the wet filter; do not use compressed air.

*NOTE: Be sure the dust filter is dry before reinstalling it in the machine.*

**TO REMOVE AND REPLACE HOPPER DUST FILTER**

1. Stop the motor and set the machine parking brake.

**FOR SAFETY: Before Leaving Or Servicing Machine; Stop On Level Surface, Set Parking Brake, Turn Off Machine And Remove Key.**

2. Unlatch the two filter cover latches and remove the filter cover.
3. Remove the two assembly bolts on each side of the filter and slide the assembly back. Remove the dust filter.

4. Inspect and clean or replace the dust filter.
5. Position the dust filter in the filter frame with the arrows on the decal pointing up.
6. Secure the filter with the shaker motor assembly.
7. Check the two filter hold-down screws. They should clear the filter by 0.03 in (1 mm).
8. Secure the filter cover on the filter frame with the two latches.
9. Check the hopper cover seal. It should be slightly compressed.

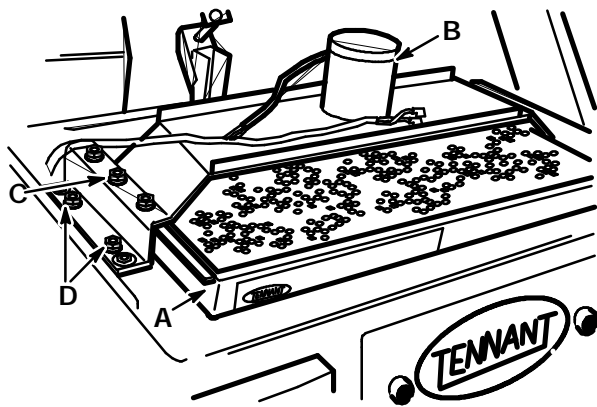

**DUST FILTER**

03389

- A. Dust Filter
- B. Shaker Motor Assembly
- C. Hold-Down Screw
- D. Assembly Bolts

**BRUSHES**

**MAIN BRUSH**

The main brush is tubular and spans the width of the machine, sweeping debris into the debris hopper. The brush should be inspected daily for wear or damage. Remove any string or wire found tangled on the main brush, main brush drive hub, or main brush idler hub.

Rotate the main brush end-for-end after every 50 hours of operation for maximum brush life and best sweeping performance. Check the main brush pattern whenever installing a new brush.

The main brush should be replaced when the remaining bristles measure 1.5 in (40 mm) or less in length.

**TO REMOVE MAIN BRUSH**

1. Stop motor and set the machine parking brake.

**FOR SAFETY: Before Leaving Or Servicing Machine; Stop On Level Surface, Set Parking Brake, Turn Off Machine And Remove Key.**

2. Lower the main brush.
3. Remove the right side access door.
4. Remove the brush idler arm retaining bolt from the arm hub.

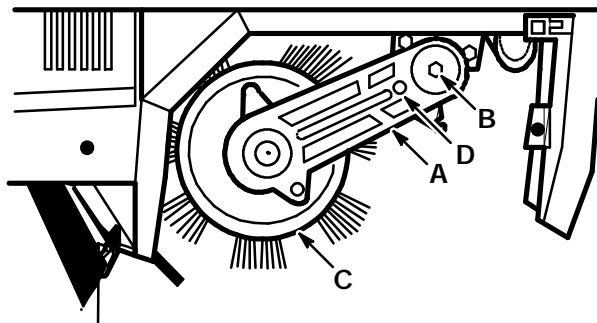

03390

**MAIN BRUSH IDLER ARM**

- A. Brush Idler Arm**
- B. Arm Retaining Bolt**
- C. Main Brush**
- D. Threaded Hole**

5. Pull the brush idler arm off the arm hub.

*NOTE: If the brush idler arm does not come off easily, thread the retaining bolt into the threaded hole on the arm. Tighten the bolt until it is tight against the backing plate. Push on the brush end of the arm and retighten the bolt. Repeat until the arm is loose.*

6. Grasp the main brush, pull it off the brush drive plug, and out of the main brush compartment.

**TO INSTALL MAIN BRUSH**

1. Raise the main brush.
2. Slide the main brush into the main brush compartment.
3. Align the main brush drive slots with the drive keys on the main brush drive plug.
4. Slide the main brush onto the drive plug. Make sure the drive slots and keys mate.
5. Align the main brush idler plug slots with the main brush keys. Slide the main brush idler plug into the main brush tube.
6. Slide the brush idler arm onto the arm hub.
7. Thread the brush idler arm retaining bolt through the idler arm and into the arm hub.
8. Tighten the brush idler arm retaining bolt.
9. Replace the right side access door.

**TO CHECK AND ADJUST MAIN BRUSH PATTERN**

1. Apply chalk, or some other material that will not blow away easily, to a smooth, level floor.
2. With the side brush and main brush raised, position the main brush over the chalked area.
3. While keeping a foot on the brakes to keep the machine from moving, lower the main brush to the floor for 15 to 20 seconds; raise the main brush and drive the machine off the test area.

*NOTE: If no chalk or other material is available, allow the brushes to spin on the floor for two minutes.*

- Observe the brush pattern made. The pattern should be of equal width across the length of the pattern.

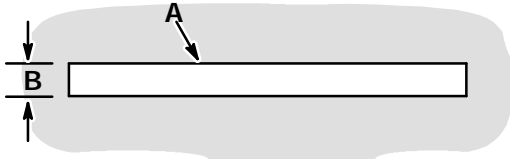

**NORMAL MAIN BRUSH PATTERN**

00582

- Main Brush Pattern
- 2 to 2.5 in (51 to 54 mm) for machines serial number 002594 and above

For machines serial number 002594 and above, and machines with the Brush Limiter Kit installed, the brush pattern width should be 2 to 2.5 in (51 to 54 mm). The brush pattern width can be adjusted by loosening and moving the brush limiter nut.

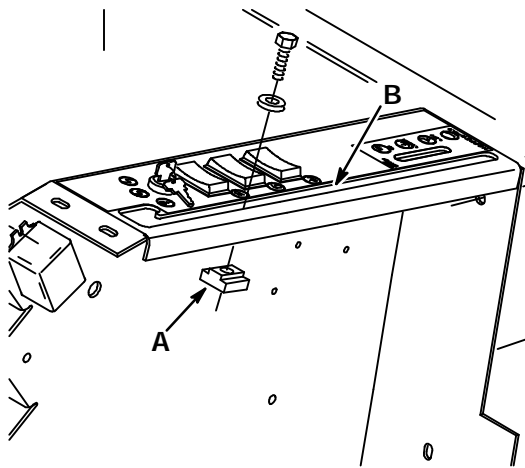

**BRUSH LIMITER NUT (For machines serial number 002594 and above)**

03487

- Brush Limiter Nut
- Main Brush Lever Slot

To decrease the width of the brush pattern, move the limiter nut forward and tighten the nut. To increase the brush pattern width, move the limiter nut back and tighten the nut.

If the main brush pattern is tapered, wider on one side by 0.50 in (15 mm) or more than the other side, perform the following leveling procedure:

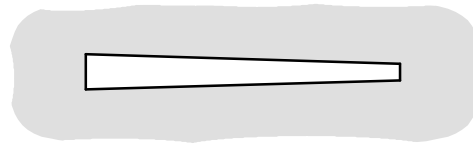

00601

**TAPERED MAIN BRUSH PATTERN**

- Park the machine on a level surface.
- Stop the motor and set the parking brake.

**FOR SAFETY: Before Leaving Or Servicing Machine; Stop On Level Surface, Set Parking Brake, Turn Off Machine And Remove Key.**

- Lower the main brush.
- Remove the right side access door.
- Remove the main brush.
- Reinstall the idler arm.
- Loosen the cross shaft bearing flange bolts.

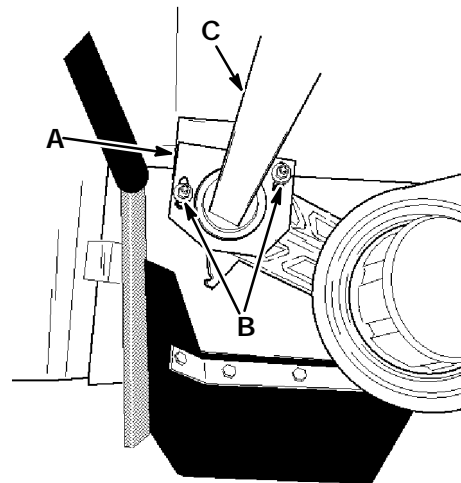

03550

**CROSS SHAFT BEARING FLANGE**

- Flange
- Bolts
- Cross Shaft

- H. Position the idler plug so it is the same distance from the floor as the drive plug and tighten the bolts.
- I. Reinstall the main brush.
- J. Recheck the main brush pattern.
- K. Replace the right side access door.

## SIDE BRUSH

The side brush sweeps debris from curbs or gutters into the path of the main brush. The side brush should be inspected daily for wear or damage. Remove any string or wire found tangled on the side brush or side brush drive hub.

The side brush pattern should be checked periodically. One-third of the side brush bristles should contact the floor when the brush is in motion. The side brush pattern adjustment is made by turning the side brush adjustment knob on the front bumper.

The side brush should be replaced when the remaining brush bristle measures 2.5 in (65 mm) in length.

### TO REMOVE SIDE BRUSH

1. Raise the hopper.
2. Engage the hopper support bar.

**⚠ WARNING: Falling Hopper. Engage Hopper Support Bar Before Working Under Hopper.**

3. Stop the motor and set the machine parking brake.

**FOR SAFETY: Before Leaving Or Servicing Machine; Stop On Level Surface, Set Parking Brake, Turn Off Machine And Remove Key.**

4. Remove the four side brush retaining bolts from the bottom of the side brush.

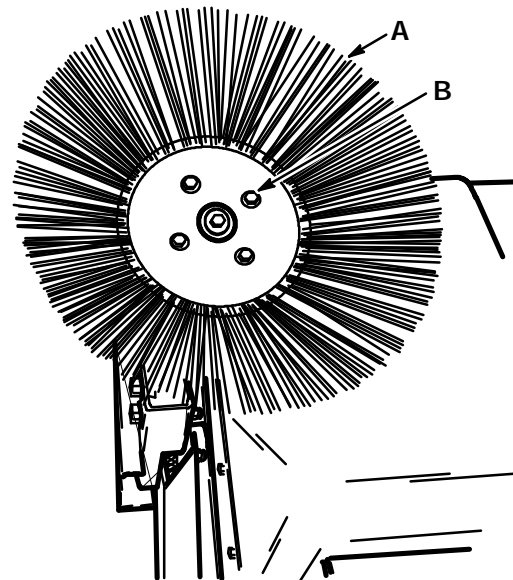

**SIDE BRUSH**

03392

- A. Side Brush
- B. Retaining Bolts

5. Slide the side brush off the side brush hub.

### TO INSTALL SIDE BRUSH

1. Position the side brush on the side brush drive hub.
2. Secure the side brush to the hub with the four bolts removed earlier.
3. Check the side brush pattern. Adjust the pattern with the side brush adjustment knob.

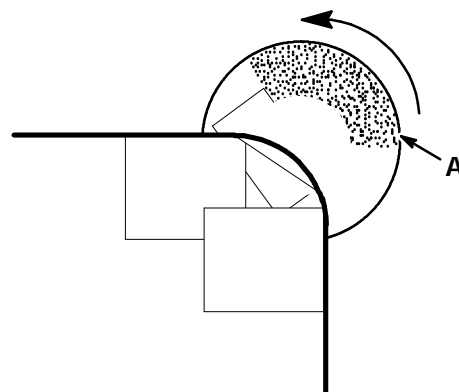

**SIDE BRUSH PATTERN**

03376

- A. Contact Area



**SKIRTS AND SEALS**

**BRUSH SKIRTS**

Brush skirts control main brush dusting. They are located on each of the brush access doors. The skirts should be inspected for wear or damage daily. They should clear the floor by 0 to 0.12 in (0 to 5 mm) at all times.

**TO REPLACE AND ADJUST BRUSH SKIRTS**

1. Park the machine on a smooth, level floor.
2. Stop the motor and set the parking brake.

**FOR SAFETY: Before Leaving Or Servicing Machine; Stop On Level Surface, Set Parking Brake, Turn Off Machine And Remove Key.**

3. Remove the side access doors.
4. Replace or loosen the skirt and retaining strip bolts. Adjust the skirt height and retighten the retaining strip bolts.

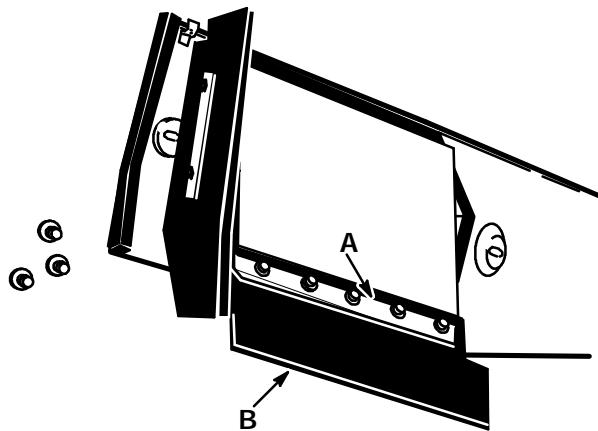

**RIGHT SIDE BRUSH SKIRT**

03388

- A. Retaining Strip
- B. Brush Skirt

5. Replace the doors.
6. Check the skirt clearance.

**REAR SKIRTS**

The rear skirts seal the brush compartment. They are located on the bottom rear of the brush compartment. The seals should be inspected for wear or damage daily.

**TO REPLACE AND ADJUST REAR SKIRTS**

1. Park the machine on a smooth, level surface.
2. Stop the motor and set the machine parking brake.

**FOR SAFETY: Before Leaving Or Servicing Machine; Stop On Level Surface, Set Parking Brake, Turn Off Machine And Remove Key.**

3. Remove the side access doors.
4. Remove the rear skirt retaining strips and the rear skirts.

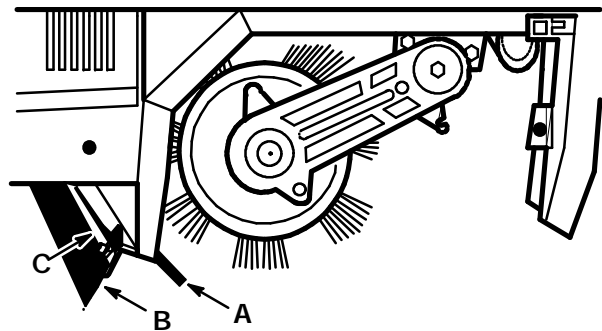

**REAR SKIRTS**

03390

- A. Brush Skirt
- B. Vertical Rear Skirt
- C. Retaining Strip

5. Loosely install new skirts with the existing retaining strips.
6. Slide the vertical rear skirt up or down so it is 0 to 0.12 in (0 to 5 mm) above the floor.
7. Retighten the retaining strip bolts.

## HOPPER LIP SKIRT

The hopper lip skirt floats over debris and helps deflect the debris into the hopper. It is located on the bottom rear of the hopper.

The hopper lip skirt should be inspected for wear or damage daily.

### TO REPLACE HOPPER LIP SKIRT

1. Empty the machine debris hopper.
2. Raise the hopper.
3. Engage the hopper support bar.

**! WARNING: Falling Hopper. Engage Hopper Support Bar Before Working Under Hopper.**

4. Stop the machine on a level surface, stop the motor, and set the machine parking brake.

**FOR SAFETY: Before Leaving Or Servicing Machine; Stop On Level Surface, Set Parking Brake, Turn Off Machine And Remove Key.**

5. Remove the skirt retaining strip and the skirt.

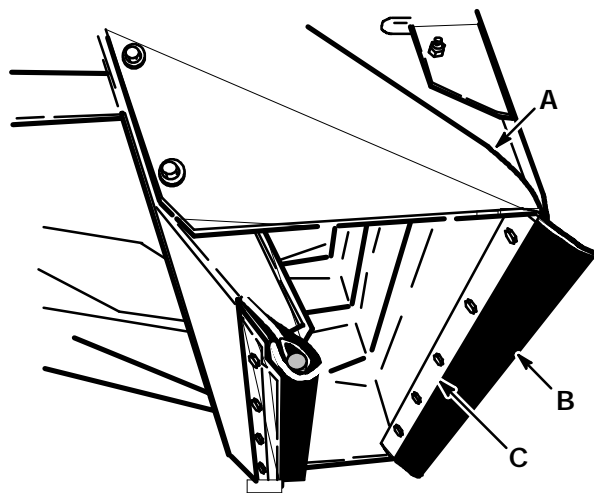

HOPPER LIP SKIRT

03384

- A. Hopper
- B. Lip Skirt
- C. Retaining Strip

6. Position the new skirt on the hopper. Secure it with the retaining strip.
7. Raise the hopper, position the hopper support bar in its storage location, and lower the hopper.

## DUST SEALS

Three seals control hopper dusting. They are the top, left and right side hopper seals. They should be inspected for wear or damage after every 100 hours of operation.

### TO REPLACE DUST SEALS

1. Empty the debris hopper.
2. Raise the hopper.
3. Engage the hopper support bar.

**! WARNING: Falling Hopper. Engage Hopper Support Bar Before Working Under Hopper.**

4. Stop the motor and set the parking brake.

**FOR SAFETY: Before Leaving Or Servicing Machine; Stop On Level Surface, Set Parking Brake, Turn Off Machine And Remove Key.**

5. Remove the side access doors to gain access to the side seals.

- Remove the retaining strip of the seal to be replaced.

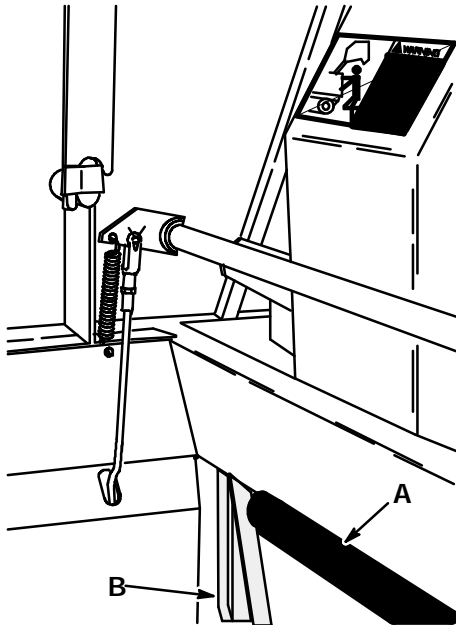

**HOPPER SEALS**

03369

- A. Top Hopper Seal**
- B. Side Hopper Seal**

- Remove the existing seal or skirt.
- Mount the new seal or skirt to the machine with the retaining strip removed earlier.
- Replace the side access doors if removed.
- Raise the hopper, place the hopper support bar in its storage position, and lower the hopper.

**HOPPER DUMP DOOR SEAL**

The hopper dump door seal allows the hopper to be high dumped without scattering debris. Check the seal for damage after every 100 hours of operation.

**TO REPLACE HOPPER DUMP DOOR SEAL**

- Empty the debris hopper.
- Raise the hopper.

- Engage the hopper support bar.

**! WARNING: Falling Hopper. Engage Hopper Support Bar Before Working Under Hopper.**

- Stop the motor and set the parking brake.

**FOR SAFETY: Before Leaving Or Servicing Machine; Stop On Level Surface, Set Parking Brake, Turn Off Machine And Remove Key.**

- Open the dump door.
- Remove the seal retaining strip.

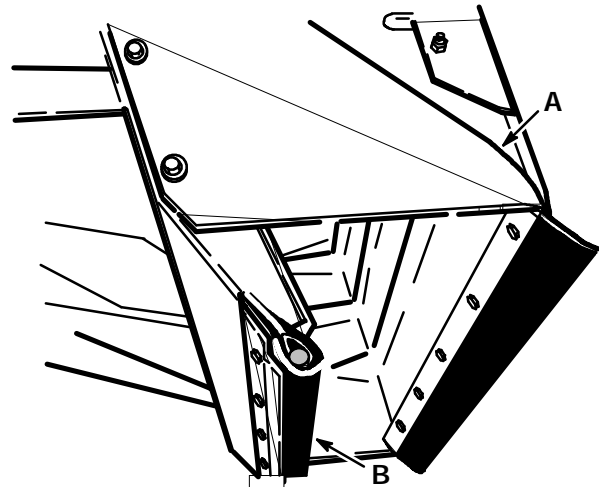

**HOPPER DUMP DOOR SEAL**

03384

- A. Hopper**
- B. Dump Door Seal**

- Remove the seal.
- Mount the new seal to the door with the sponge core and retaining strip removed earlier.
- Raise the hopper, position the hopper support bar in its storage position, and lower the hopper.

**VACUUM FAN SEAL**

The vacuum fan seal seals the vacuum fan to the filter cover. Check the seal for damage after every 100 hours of operation.

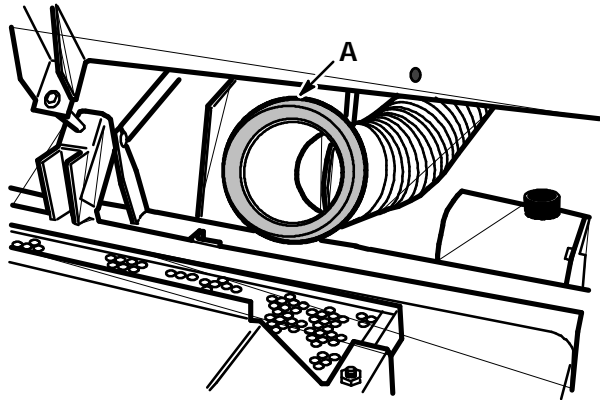

03387

**VACUUM FAN SEAL**

**A. Vacuum Fan Seal**

**FILTER COVER SEAL**

The filter cover seal seals the filter box to the filter cover. Check the seal for damage after every 100 hours of operation.

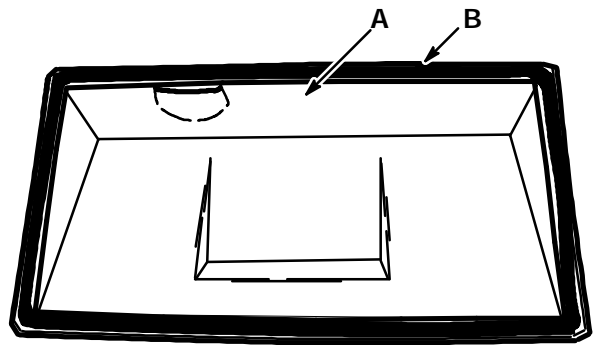

03375

**FILTER COVER SEAL**

**A. Filter Cover  
B. Seal**

**BRAKES AND TIRES**

**BRAKES**

The foot brake and the parking brake operate the linkage which controls the brakes on the front wheels.

The foot brake needs no regular adjustment. The parking brake should be adjusted after every 200 hours of operation or whenever it becomes very easy to set.

To adjust the parking brake, turn the knurled knob on the end of the parking brake clockwise. If the knob adjustment is inadequate, remove the clevis pin from each brake assembly, turn the clevis ends an equal amount, reconnect the clevis pins, and readjust the parking brake.

**TIRES**

All of the machine tires are solid. They should be inspected for wear after every 100 hours of operation.

**REAR WHEEL**

Torque the rear wheel nuts in a star pattern to 122 to 150 Nm (90 to 110 ft lb) after the first 50-hours of operation, and every 800 hours there after.

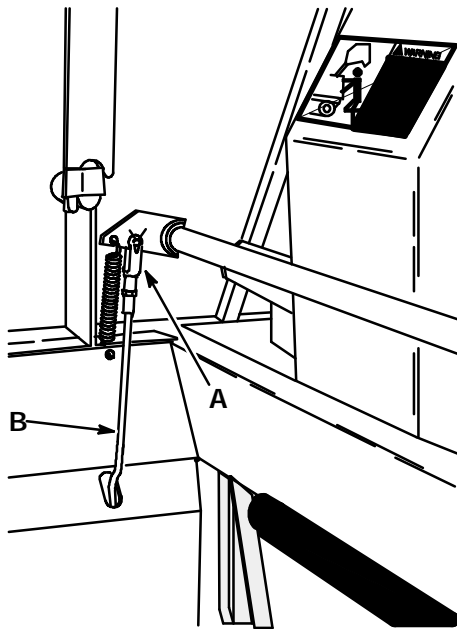

**BRAKE ASSEMBLY**

03369

- A. Clevis
- B. Brake Rod



## SECTION 4

## CONTENTS

	Page
HARDWARE INFORMATION .....	4-3
STANDARD BOLT TORQUE CHART ..	4-3
METRIC BOLT TORQUE CHART .....	4-3
BOLT IDENTIFICATION .....	4-3
THREAD SEALANT AND LOCKING COMPOUNDS .....	4-3
HYDRAULIC FITTING INFORMATION ....	4-4
HYDRAULIC TAPERED PIPE FITTING (NPT) TORQUE CHART .....	4-4
HYDRAULIC TAPERED SEAT FITTING (JIC) TORQUE CHART .....	4-4
HYDRAULIC O-RING FITTING TORQUE CHART .....	4-4





**HARDWARE INFORMATION**

The following charts state standard plated hardware tightening ranges for normal assembly applications. Decrease the specified torque by 20% when using a thread lubricant. Do not substitute lower grade hardware for higher grade hardware. If higher grade hardware than specified is substituted, tighten only to the specified hardware torque value to avoid damaging the threads of the part being threaded into, as when threading into speed nuts or weldments.

Front wheel nut - 10 to 12 ft lb (14 to 16 Nm) while turning wheel, tighten to spec, then backoff, retighten by hand till snug, then turn to next slot.

Damper solenoid nut - 20 to 23 in lb (2.5 to 3 Nm).

Pitman arm to steering column nut - 160 ft lb (215 Nm).

Propelling motor shaft thin nylon lock nut - 7 to 10 ft lb (9 to 14 Nm).





Propelling motor adapter bolts - 16 to 21 ft lb (21 to 28 Nm) with Loctite 242 blue on threads. Use loctite 515 sealant on the pilot fillet of the motor and the adapter.

**STANDARD BOLT TORQUE CHART**

Thread Size	SAE Grade 5 Torque ft lb (Nm)	SAE Grade 8 Torque ft lb (Nm)
0.25 in	7-10 (9-14)	10-13 (14-38)
0.31 in	15-20 (20-27)	20-26 (27-35)
0.38 in	27-35 (37-47)	36-47 (49-64)
0.44 in	43-56 (58-76)	53-76 (72-103)
0.50 in	65-85 (88-115)	89-116 (121-157)
0.62 in	130-170 (176-231)	117-265 (159-359)
0.75 in	215-280 (291-380)	313-407 (424-552)
1.00 in	500-650 (678-881)	757-984 (1026-1334)

*NOTE: Decrease torque by 20% when using a thread lubricant.*

**BOLT IDENTIFICATION**

Identification Grade Marking	Specification and Grade
	SAE-Grade 5
	SAE-Grade 8
	ISO-Grade 8.8
	ISO-Grade 10.9

01395

**METRIC BOLT TORQUE CHART**

Thread Size	Class 8.8 Torque ft lb (Nm)	Class 10.9 Torque ft lb (Nm)
M4	2 (3)	3 (4)
M5	4 (5)	6 (8)
M6	7 (9)	10 (14)
M8	18 (24)	25 (34)
M10	32 (43)	47 (64)
M12	58 (79)	83 (112)
M14	94 (127)	133 (180)
M16	144 (195)	196 (265)
M20	260 (352)	336 (455)
M24	470 (637)	664 (900)

*NOTE: Decrease torque by 20% when using a thread lubricant.*

Exceptions to the above chart:

Main brush drive plug nut - 30 ft lb (40 Nm) then tighten to next slot.

Brake unit to hub sockethead screw - 9 to 12 ft lb (12 to 16 Nm) with Loctite 242 blue.

**THREAD SEALANT AND LOCKING COMPOUNDS**

Thread sealants and locking compounds may be used on this machine. They include the following:

Loctite 515 sealant - gasket forming material. TENNANT Part No. 75567, 15 oz (440 ml) cartridge.

Loctite 242 blue - medium strength thread locking compound. TENNANT Part No. 32676, 0.5 ml tube.

Loctite 271 red - high strength thread locking compound. TENNANT Part No. 19857, 0.5 ml tube.

**HYDRAULIC FITTING INFORMATION**

**HYDRAULIC TAPERED PIPE FITTING (NPT)  
TORQUE CHART**

*NOTE: Ratings listed are when using teflon thread seal.*

Size	Minimum Torque	Maximum Torque
1/4 NPT	10 ft lb (14 Nm)	30 ft lb (41 Nm)
1/2 NPT	25 ft lb (34 Nm)	50 ft lb (68 Nm)
3/4 NPT	50 ft lb (68 Nm)	100 ft lb (136 Nm)

**HYDRAULIC TAPERED SEAT FITTING (JIC)  
TORQUE CHART**

Tube O.D. (in)	Thread Size	Maximum Torque
0.25	0.44-20	9 ft lb (12 Nm)
0.38	0.56-18	20 ft lb (27 Nm)
0.50	0.75-16	30 ft lb (41 Nm)
0.62	0.88-14	40 ft lb (54 Nm)
0.75	1.12-12	70 ft lb (95 Nm)
1.0	1.31-12	90 ft lb (122 Nm)

**HYDRAULIC O-RING FITTING TORQUE  
CHART**

Tube O.D.(in)	Thread Size	Minimum Torque	Maximum Torque
0.25	0.44-20	6 ft lb (8 Nm)	9 ft lb (12 Nm)
0.38	0.56-18	13 ft lb (18 Nm)	20 ft lb (27 Nm)
		*10 ft lb (14 Nm)	12 ft lb (16 Nm)
0.50	0.75-16	20 ft lb (27 Nm)	30 ft lb (41 Nm)
		*21 ft lb (28 Nm)	24 ft lb (33 Nm)
0.62	0.88-14	25 ft lb (34 Nm)	40 ft lb (54 Nm)
0.75	1.12-12	45 ft lb (61 Nm)	70 ft lb (95 Nm)
1.0	1.31-12	60 ft lb (81 Nm)	90 ft lb (122 Nm)

*NOTE: Do not use sealant on o-ring threads.*

\*Aluminum bodied components