

SECTION CONTENTS

<u>MODEL No.</u>	<u>PAGE No.</u>
RYC300	14-2 THRU 14-5

[MODEL No.](#)

RYC300

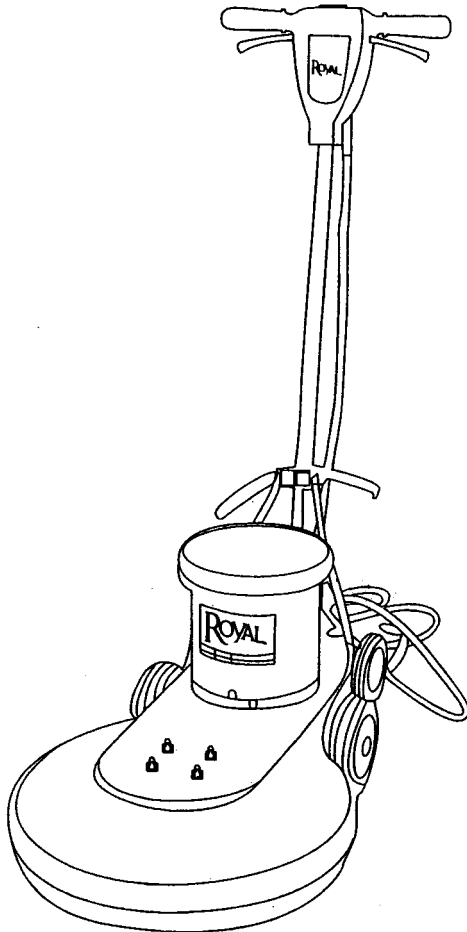

FLOOREQUIPMENTPARTS.COM

- * PRICING, SPECIFICATION'S, AND PRODUCT AVAILABILITY ARE SUBJECT TO CHANGE WITHOUT NOTICE. PRICING IS FOB FACTORY, GLENWILLOW, OH
- * ALL INFORMATION CONTAINED WITHIN THIS SERVICE MANUAL IS PROPRIETARY INFORMATION OF TTI FLOOR CARE NORTH AMERICA.
- * **WARNING:** TO REDUCE THE RISK OF ELECTRICAL SHOCK OR INJURY, ALWAYS DISCONNECT THE APPLIANCE CORD FROM THE ELECTRICAL OUTLET OR REMOVE BATTERY PRIOR TO SERVICING THE UNIT.

ASSEMBLY SCHEMATIC

MODEL NO.

RYC300

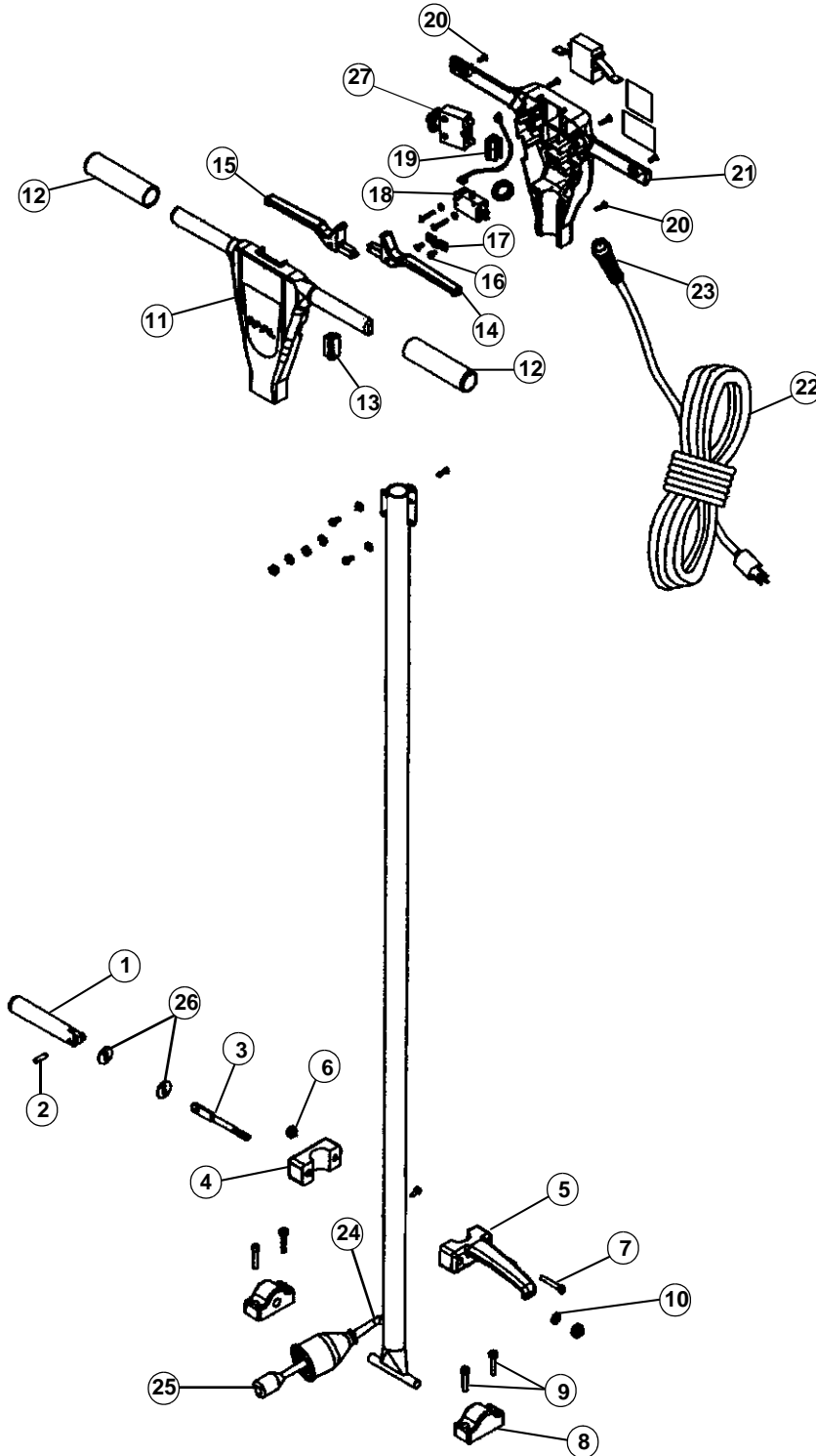

PART LISTING / PRICE LIST

MODEL No.

RYC300

Item	Part Number	Models To Fit	Part Description
1	AS312215	RYC300	HANDLE RELEASE
2	VF30017	RYC300	SCREW
3	VF30015	RYC300	HANDLE RELEASE BOLT
4	VF30014	RYC300	COVER, HOOK
5	VF30013	RYC300	CORD HOOK
6	VF13503	RYC300	LOCK NUT M-8 X 5.7
7	VF14114	RYC300	SCREW M-5 X 55
8	VF30011	RYC300	CLAMP BLOCK - HANDLE
9	VF14053	RYC300	HEX SCREW M-6 X 25
10	VF13504	RYC300	LOCK NUT M-10
11	AS312208	RYC300	FRONT HANDLE COVER
12	VF48310	RYC300	HANDLE GRIP
13	GV40238H	RYC300	LEVER SOLUTION COVER
14	AS312210	RYC300	LEFT LEVER SWITCH
15	AS312211	RYC300	RIGHT LEVER SWITCH
16	V V13661	RYC300	SCREW M-4 X 12
17	VF48309	RYC300	CLAMP BLOCK
18	VF99023	RYC300	SWITCH ASSEMBLY
19	AS312203	RYC300	PLUG
20	GT13009	RYC300	SCREW M-5 X 30
21	AS312209	RYC300	REAR HANDLE COVER
22	VF45126	RYC300	ORANGE CORD
	VF45119	RYC300	YELLOW CORD
23	AS22009	RYC300	STRAIN RELIEF
24	VF50120	RYC300	GROMMET
25	VF45120	RYC300	HANDLE CORD
26	VF30018	RYC300	WASHER
27	VF99010C	RYC300	CIRCUIT BREAKER - 17 AMP

ASSEMBLY SCHEMATIC

MODEL NO.

RYC300

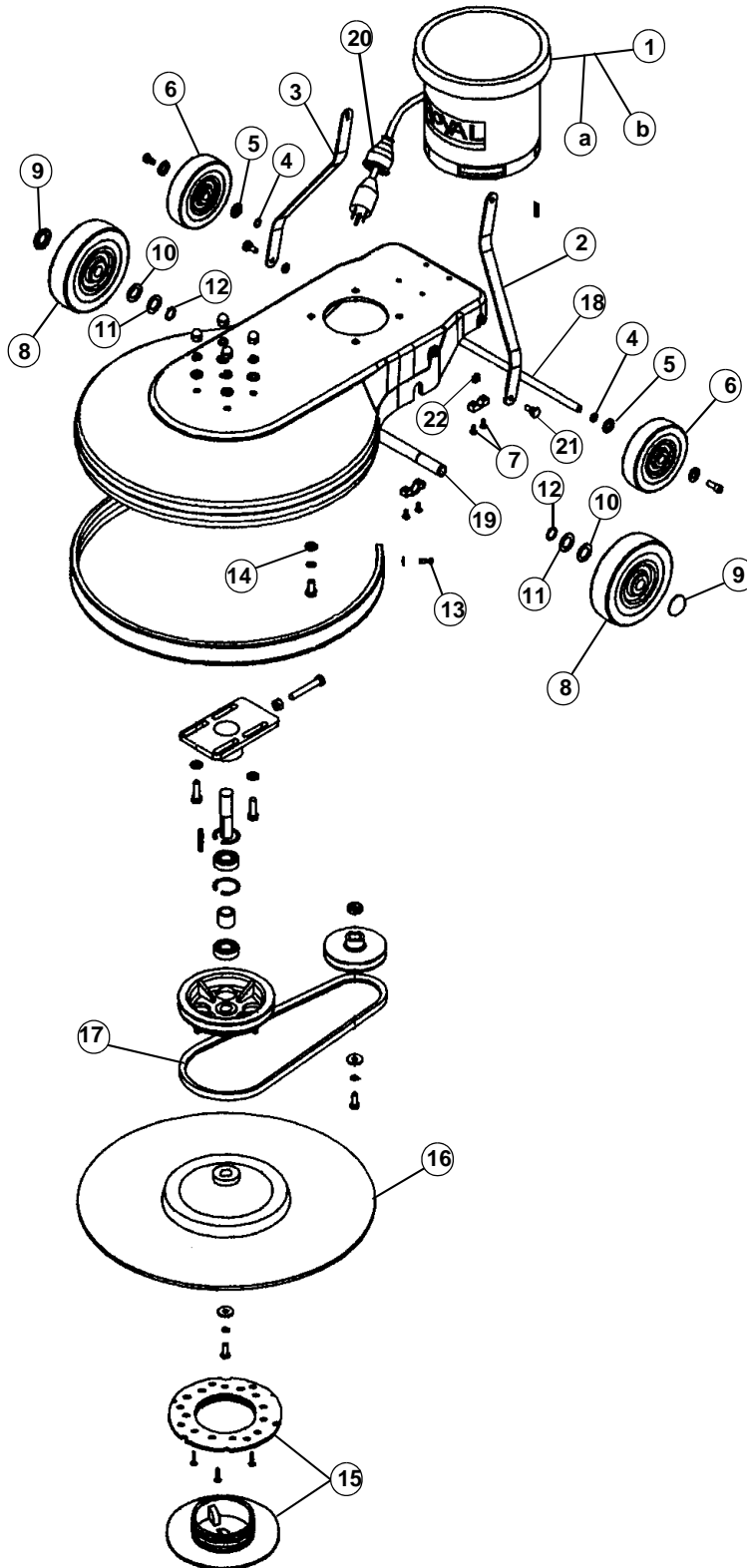

PART LISTING / PRICE LIST

MODEL No.

RYC300

Item	Part Number	Models To Fit	Part Description
1	VF99925R	RYC300	MOTOR
a	VF999262	RYC300	CARBON BRUSH (SET/4)
b	VF999261	RYC300	RECTIFIER
2	VF53112	RYC300	LEFT BRACKET
3	VF53113	RYC300	RIGHT BRACKET
4	VF13520	RYC300	SMALL LOCK WASHER
5	VF50119	RYC300	LARGE LOCK WASHER
6	VF48202	RYC300	WHEEL 5"
7	V V13621	RYC300	SELF TAPPING SCREW 5 X 20
8	VF47058	RYC300	WHEEL 6"
9	VA96851	RYC300	FRONT CAP AXLE
10	VF47027	RYC300	WASHER
11	VF50123	RYC300	WASHER
12	VF14004	RYC300	RETAINING WHEEL
13	VA13474	RYC300	SCREW M-5 X 16
14	VF13517	RYC300	PLAIN WASHER
15	VF99003A	RYC300	PAD FASTENER
16	VF99024	RYC300	PAD HOLDER
17	VF14079E	RYC300	BELT - 39"
18	VF52011A	RYC300	REAR AXLE
19	VF52010R	RYC300	FRONT AXLE
20	AS41901	RYC300	MALE PLUG PROTECTOR - SMALL
21	VF53107	RYC300	HEX SCREW - BRACKET
22	VF13514	RYC300	WASHER