

SECTION CONTENTS

<u>MODEL No.</u>	<u>PAGE No.</u>
RY5300	11-2 THRU 11-4
RY5400	11-2 THRU 11-4

[MODEL No.](#)

RY5300
RY5400

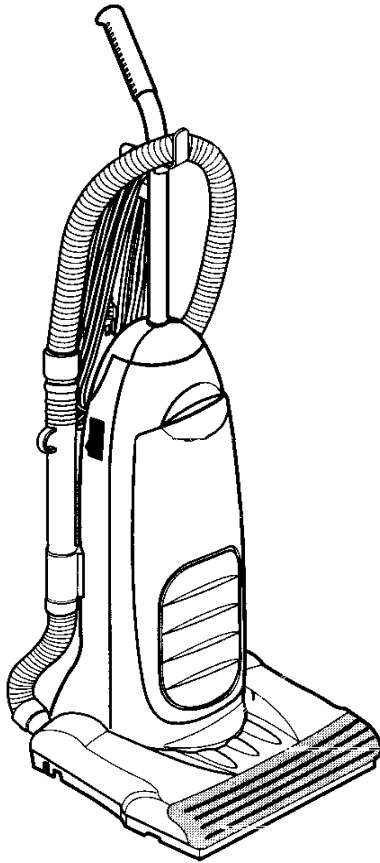

FLOOR EQUIPMENT PARTS.COM

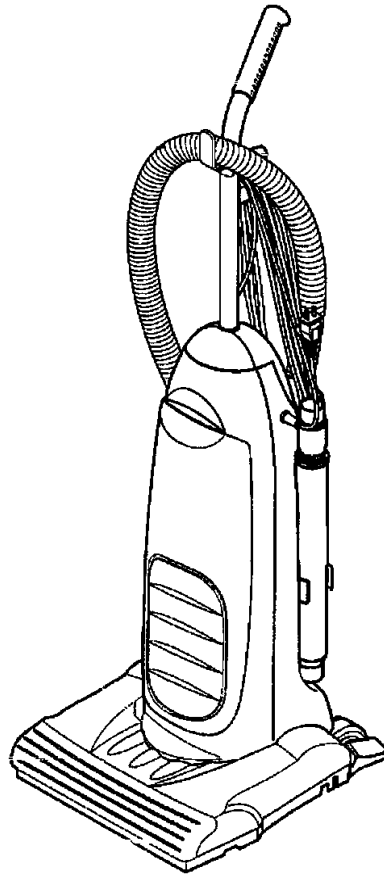

- * PRICING, SPECIFICATION'S, AND PRODUCT AVAILABILITY ARE SUBJECT TO CHANGE WITHOUT NOTICE. PRICING IS FOB FACTORY, GLENWILLOW, OH
- * ALL INFORMATION CONTAINED WITHIN THIS SERVICE MANUAL IS PROPRIETARY INFORMATION OF TTI FLOOR CARE NORTH AMERICA.
- * **WARNING:** TO REDUCE THE RISK OF ELECTRICAL SHOCK OR INJURY, ALWAYS DISCONNECT THE APPLIANCE CORD FROM THE ELECTRICAL OUTLET OR REMOVE BATTERY PRIOR TO SERVICING THE UNIT.

ASSEMBLY SCHEMATIC

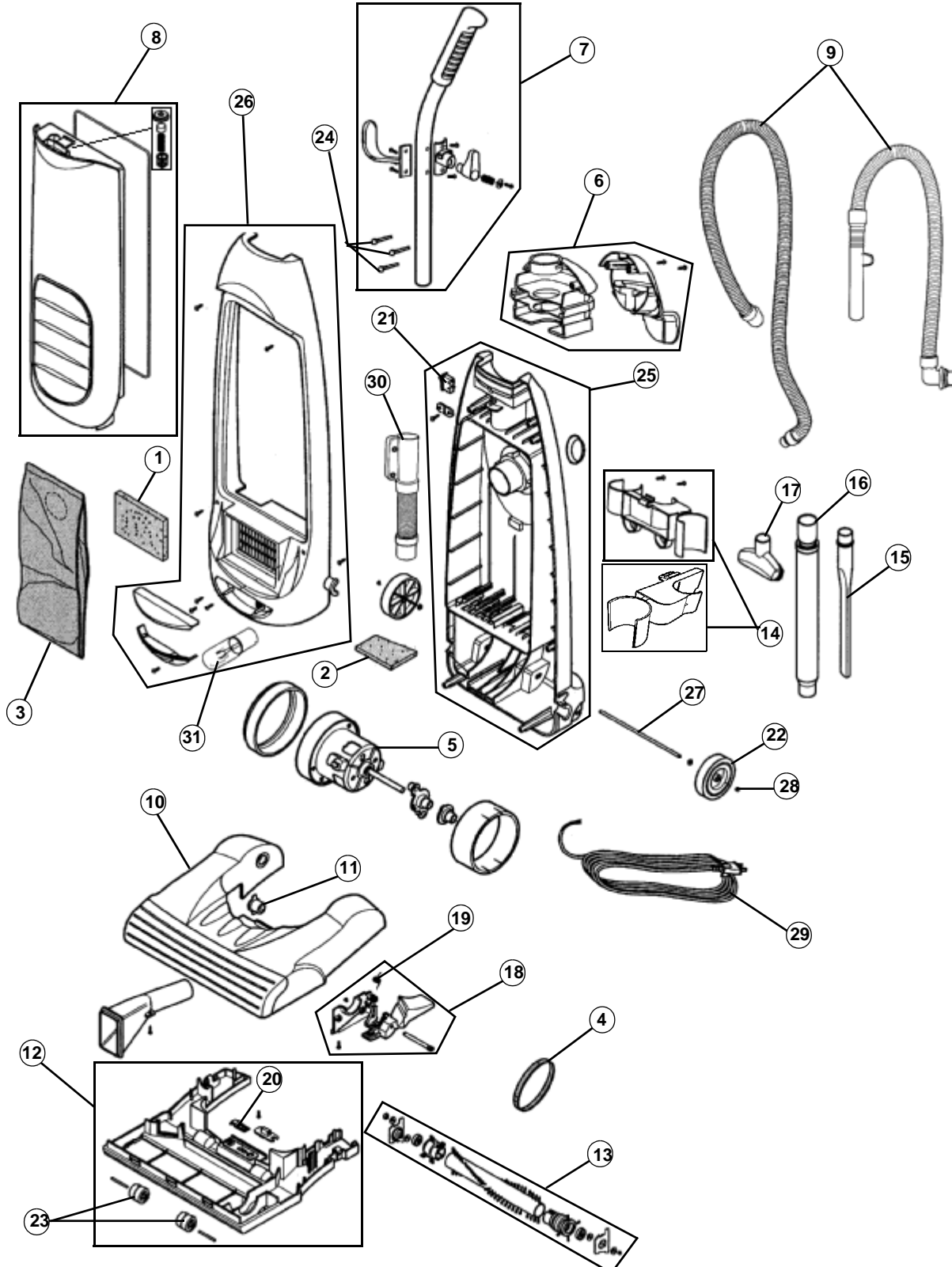

MODEL NO.

RY5300
RY5400



BAGGED COMMERCIAL/ RESIDENTIAL UPRIGHT

11

PART LISTING / PRICE LIST

Item	Part Number	Models To Fit	Part Description
1	1231F13000	RY5300, RY5400	EXHAUST FILTER
	3231F13001	RY5300, RY5400	EXHAUST FILTER - 2 PACK
2	1231LG1000	RY5300, RY5400	BAG CHAMBER FILTER
3	1423002000	RY5300, RY5400	TYPE T BAG
	3423002001	RY5300, RY5400	TYPE T BAG - 7 PACK
4	4400FI3348	RY5300, RY5400	STYLE 16 BELT
5	4681FI2460	RY5300, RY5400	MOTOR ASSEMBLY
6	3550FI1556	RY5300	CARRYING HANDLE W/SCREWS - ORG
	3550FI15BL	RY5400	CARRYING HANDLE W/SCREWS - BLUE
7	5201FI2449	RY5300, RY5400	HANDLE ASSEMBLY
8	3550FI1678	RY5300	FRONT PANEL WITH GASKET - ORANGE
	3551FI1627	RY5400	FRONT PANEL WITH GASKET - BLUE
9	5215FI1338	RY5300	FLEXIBLE HOSE ASSEMBLY-OLD STYLE
	52158I1351	RY5300 - REVISED RY5400	FLEXIBLE QUICK DRAW HOSE ASSEMBLY WITH HANDLE
10	3550FI1679	RY5300	NOZZLE COVER - ORANGE
	3551FI1626	RY5400	NOZZLE COVER - BLUE
11	4930FI4671	RY5300, RY5400	FIXING HOLDER
12	3300FI1457	RY5300	NOZZLE BASE ORDER 3301FI1134
	3301FI1134	RY5400	NOZZLE BASE
13	5973FI1003	RY5300, RY5400	BRUSH ROLL ASSEMBLY
14	3091FI1001	RY5300	TOOL HOLDER - GRAY OLD STYLE
	30918I3001	RY5400	TOOL HOLDER - GRAY
15	5058FI2213	RY5300, RY5400	CREVICE TOOL
16	5063FI1445	RY5300, RY5400	WAND ASSEMBLY
17	5203FI3739	RY5300, RY5400	DUSTING BRUSH
18	3059FI3003	RY5300, RY5400	HANDLE RELEASE PEDAL ASSEMBLY
19	4970FI4704	RY5300, RY5400	HANDLE RELEASE PEDAL SPRING
20	4970FI4699	RY5300, RY5400	SLIDE PIECE

MODEL No.

RY5300
RY5400



**BAGGED
COMMERCIAL/ RESIDENTIAL
UPRIGHT**

11

PART LISTING / PRICE LIST

Item	Part Number	Models To Fit	Part Description
21	6601FI3487	RY5300, RY5400	SWITCH ASSEMBLY
22	4660FI3740	RY5300, RY5400	LARGE WHEEL
23	4660FI4566	RY5300, RY5400	SMALL WHEEL
24	1JC0300000	RY5300, RY5400	HANDLE SCREW - (3)
25	3040FI1531	RY5300	BACK PANEL - ORANGE / NON REVISED
	3040FI1472	RY5400	BACK PANEL - BLUE
26	3040FI5300	RY5300	FRONT BODY COVER - ORANGE
	3551FI1498	RY5400	FRONT BODY COVER - BLUE
27	4370FI4598	RY5300, RY5400	WHEEL SHAFT
28	4080070A	RY5300, RY5400	E-CLIP / WHEEL
29	1061136AU0	RY5300	CORD 50' / 3 WIRE - ORANGE
	6411FI2451	RY5400	CORD / 2 WIRE - BLUE
30	52158I2002	RY5300 - REVISED RY5400	LOWER HOSE
31	1880630000	RY5300, RY5400	LIGHT BULB - 120 VOLT 15 WATT

MODEL No.

RY5300
RY5400