



Model Part No.: 608520

MONSOON™

FLOOR STRIPPER APPLICATOR

OPERATOR AND PARTS MANUAL

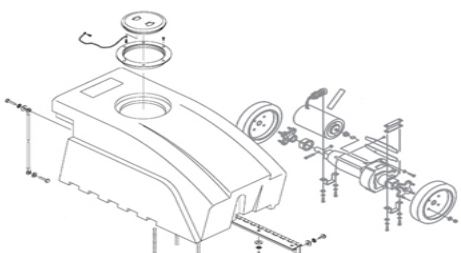

FLOOR-EQUIPMENT-PARTS.COM

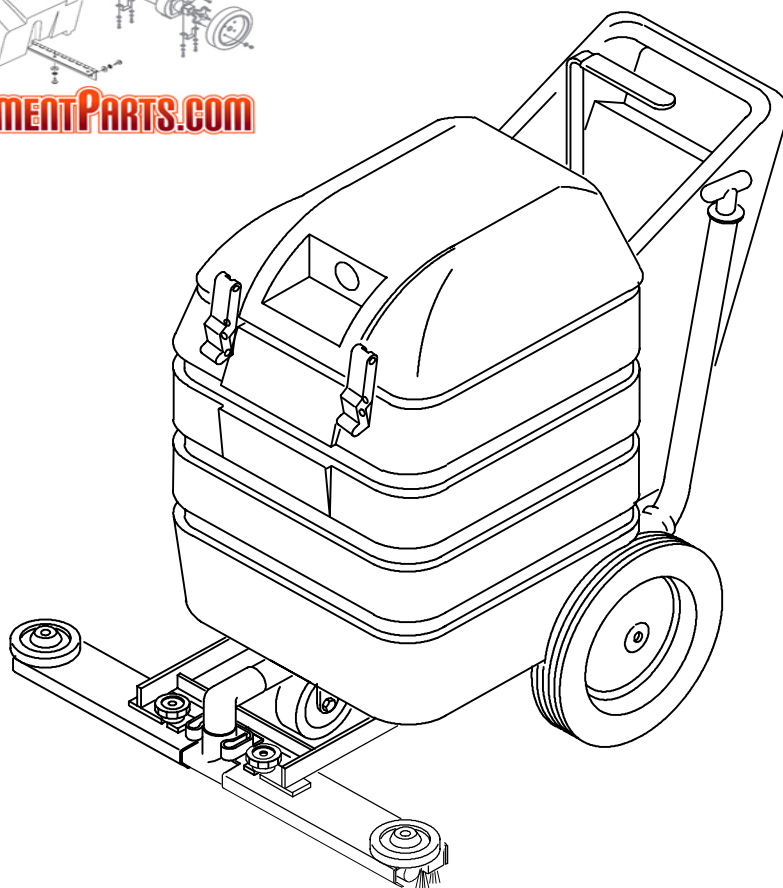

www.nobles.com

608521
Rev. 01 (08-2007)



OPERATION

This manual is furnished with each new model. It provides necessary installation, operation and maintenance instructions and an illustrated parts list. **Read this manual completely and understand the machine before operating or servicing it.**

This machine will provide excellent service. However, the best results will be obtained at minimum costs if:

- The machine is operated with reasonable care.
- The machine is maintained regularly - per the machine maintenance instructions provided.
- The machine is maintained with manufacturer supplied or equivalent parts.

MACHINE DATA

Please fill out at time of installation for future reference.

Model No.- _____

Install. Date - _____

Serial No.- _____

©1999, 2007 Tennant Company Printed in the U.S.A.
Nobles is a registered United States trademark of Tennant Company.

TABLE OF CONTENTS

MACHINE APPLICATION	2
MACHINE COMPONENTS	2
MACHINE INSTALLATION	3
UNCRATING MACHINE	3
ATTACHING HANDLE	3
ATTACHING SOLUTION FLOW LEVER	
LINKAGE	3
INSTALLING DISPENSER ASSEMBLY	3
MACHINE SETUP	4
MACHINE OPERATION	4
DRAINING TANK	5
MACHINE MAINTENANCE	5
TROUBLE SHOOTING	5
SPECIFICATIONS	5
PARTS LIST	6
MAIN HOUSING ASSEMBLY	6
DISPENSER ASSEMBLY	8

MACHINE APPLICATION

This machine is intended for commercial use. It is suited to apply floor stripper solvent on floors in an indoor environment and is not constructed for any other use. Use only recommended stripping solvents.

⚠ WARNING: Flammable materials can cause an explosion or fire. Do not use flammable materials in tank(s).

MACHINE COMPONENTS

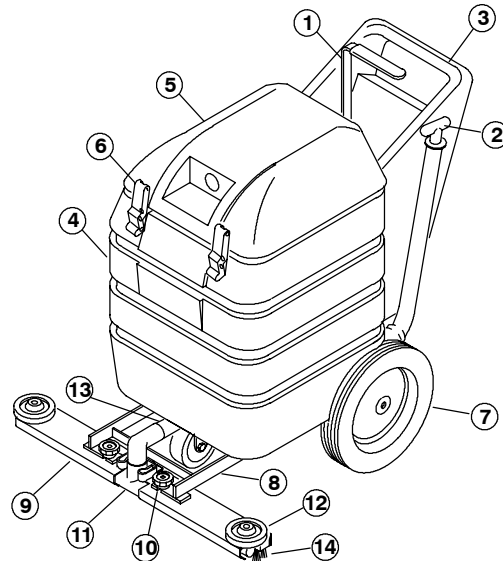

1. Solution Flow Lever
2. Drain Hose Knob
3. Handle
4. 76L (20 Gallon) Solution Tank
5. Solution Tank Cover
6. Cover Latches
7. 250 mm (10 inch) Stair Climbing Wheels
8. Dispenser Frame Weldment
9. Dispenser Assembly
10. Dispenser Assembly Knobs
11. Drip Bar
12. Wall Rollers
13. Clear Solution Hose
14. Brushes

MACHINE INSTALLATION

UNCRATING MACHINE

Carefully check carton for signs of damage. Report damages at once to carrier.

Check carton contents list below to ensure everything is included. Contact your distributor for missing items.

Contents:

- Machine
- Handle
- Hardware package (stored in solution tank)
- Dispenser Frame Weldment w/ Lift Pedal
- Dispenser Assembly w/2 Knobs
- 760 mm (30 in) Drip Bar

ATTACHING HANDLE

1. Attach handle to machine. Hardware package is stored in solution tank.
2. Align handle to mounting holes and fasten with (4) 3/8x1-1/2" hex head screws with flat and lock washers. Use a 9/16" wrench (Figure 1.).

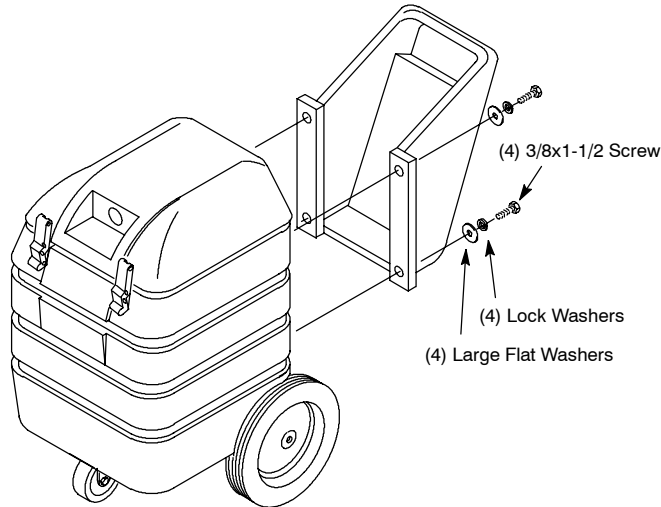

FIG. 1.

ATTACHING SOLUTION FLOW LEVER LINKAGE

1. Connect solution flow lever to solution valve linkage arm.
2. Align solution lever to linkage arm and connect with allen screw, (2) small flat washer and nylon lock nut. Use a 5/32" allen wrench and 7/16" wrench (Figure 2.).

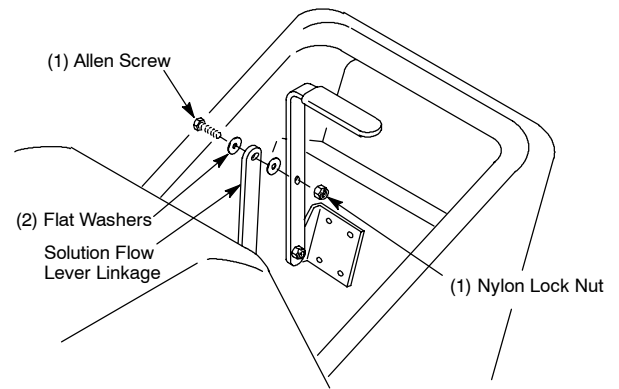

FIG. 2.

INSTALLING DISPENSER ASSEMBLY

1. Place dispenser frame weldment under machine and fasten to mounting bracket that is factory installed. Use two clevis pins as shown, secure with two hair pins (Figure 3.).

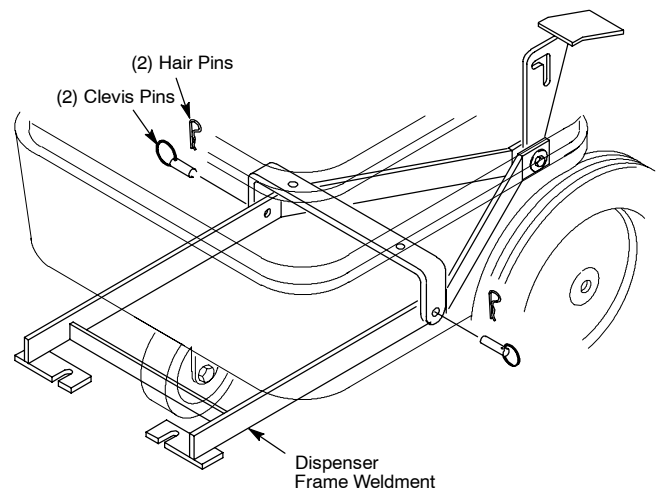

FIG. 3.

2. Position pedal between pedal brackets at rear of machine. Insert clevis pin through brackets and pedal, secure with hair pin (Figure 4.).

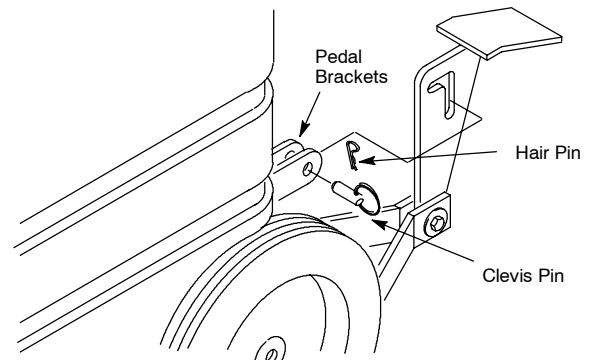

FIG. 4.

OPERATION

- Loosen (2) knobs and attach dispenser assembly to frame weldment, tighten down knobs. Brush side should face towards machine (Figure 5.).

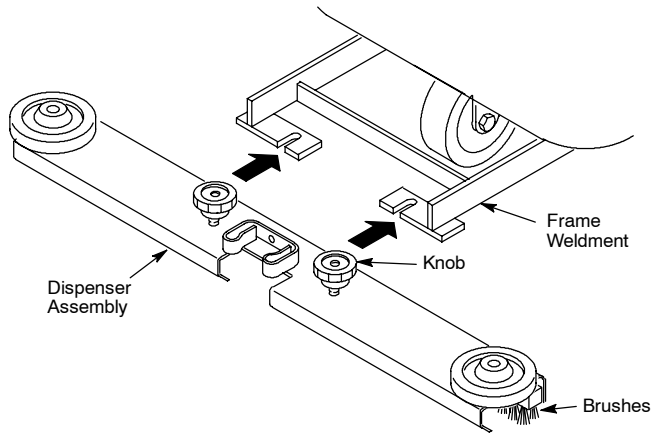

FIG. 5.

- Position drip bar into dispenser assembly and snap bar onto retainer clip. Then connect elbow on clear hose to drip bar (Figure 6.).

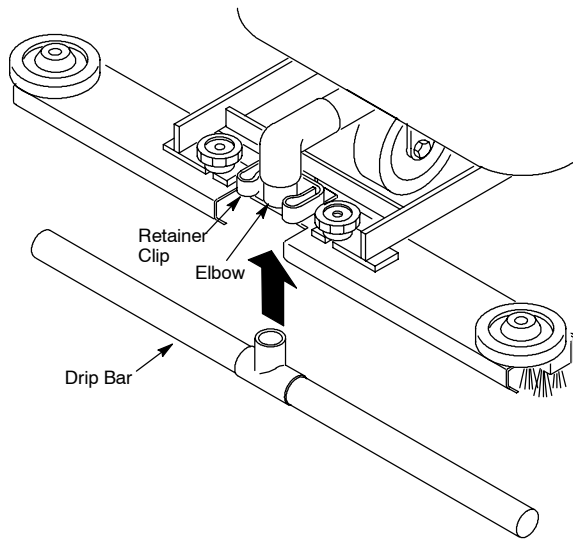

FIG. 6.

- Raise dispenser assembly off floor. Step down on pedal to raise dispenser to transport position (Figure 7.).

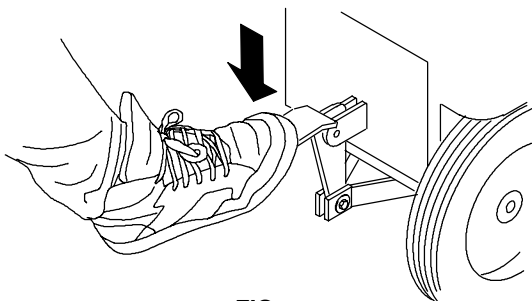

FIG. 7.

MACHINE SETUP

- Push solution flow lever completely forward to shut off solution flow.
- Open solution tank cover and pour up to 76L (20 gal) of recommended stripper solvent into tank.

FOR SAFETY: When using machine, follow mixing and handling instructions on chemical containers.

NOTE: See Flow Rates on page 5.

⚠ WARNING: Flammable materials can cause an explosion or fire. Do not use flammable materials in tank(s).

MACHINE OPERATION

NOTE: This machine is designed to be pushed forward for easy maneuvering and quick applying, however if desired you may pull the machine backwards, but you must rotate the dispenser assembly 180°.

- Lower dispenser assembly to floor. Push pedal forward to release from transport position (Figure 8.).

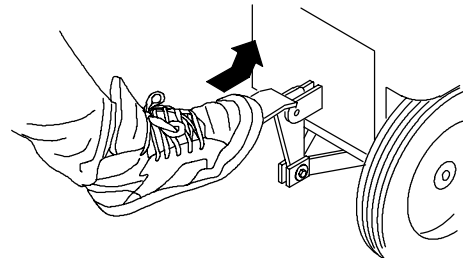

FIG. 8.

NOTE: Use stripper traction shoes when applying stripper on floor.

- To start solution flow, pull Solution Flow Lever completely backwards. You can regulate the amount of flow by pushing lever forward (Figure 9.).

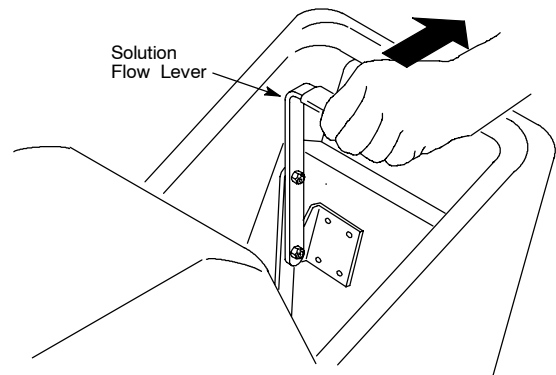

FIG. 9.

3. Begin applying stripper by pushing machine at a moderate walking pace.

FOR SAFETY: When using machine, go slow on inclines and slippery surfaces.

DRAINING TANK

1. Raise dispenser assembly to transport position and push machine to draining area.
2. To drain excess stripper solvent, remove drain hose from holder and twist off drain hose plug.
3. Perform maintenance procedures before storing machine.

MACHINE MAINTENANCE

AFTER EACH USE:

1. Remove and rinse out dispenser drip bar and brushes.
2. Rinse out tank and clear hose thoroughly.
3. Clean machine housing with a nonabrasive, non-solvent cleaner.
4. Periodically lubricate wheels and casters with a water resistant oil.

TROUBLE SHOOTING

PROBLEM	CAUSE	SOLUTION
No solution flow.	Dispenser drip bar is plugged.	Unplug drip bar.
	Solution flow lever not activated.	Activate lever.
	Solution valve is plugged.	Replace or unplug valve.
	Clear hose is plugged.	Remove and flush out.

SPECIFICATIONS

Model	Monsoon™
LENGTH	840 mm (33 in)
WIDTH	480 mm (19 in)
HEIGHT	860 mm (34 in)
WEIGHT	29Kg (64.5 lbs)
DISPENSER ASSEMBLY WIDTH	810 mm (32 in)
TANK CAPACITY	76L (20 Gal)
SOLUTION FLOW RATE	14L (3.6 Gal) per minute (max. flow) 2509 Sq. meter (27,000 Sq. ft) per full tank

PARTS LIST

MAIN HOUSING ASSEMBLY

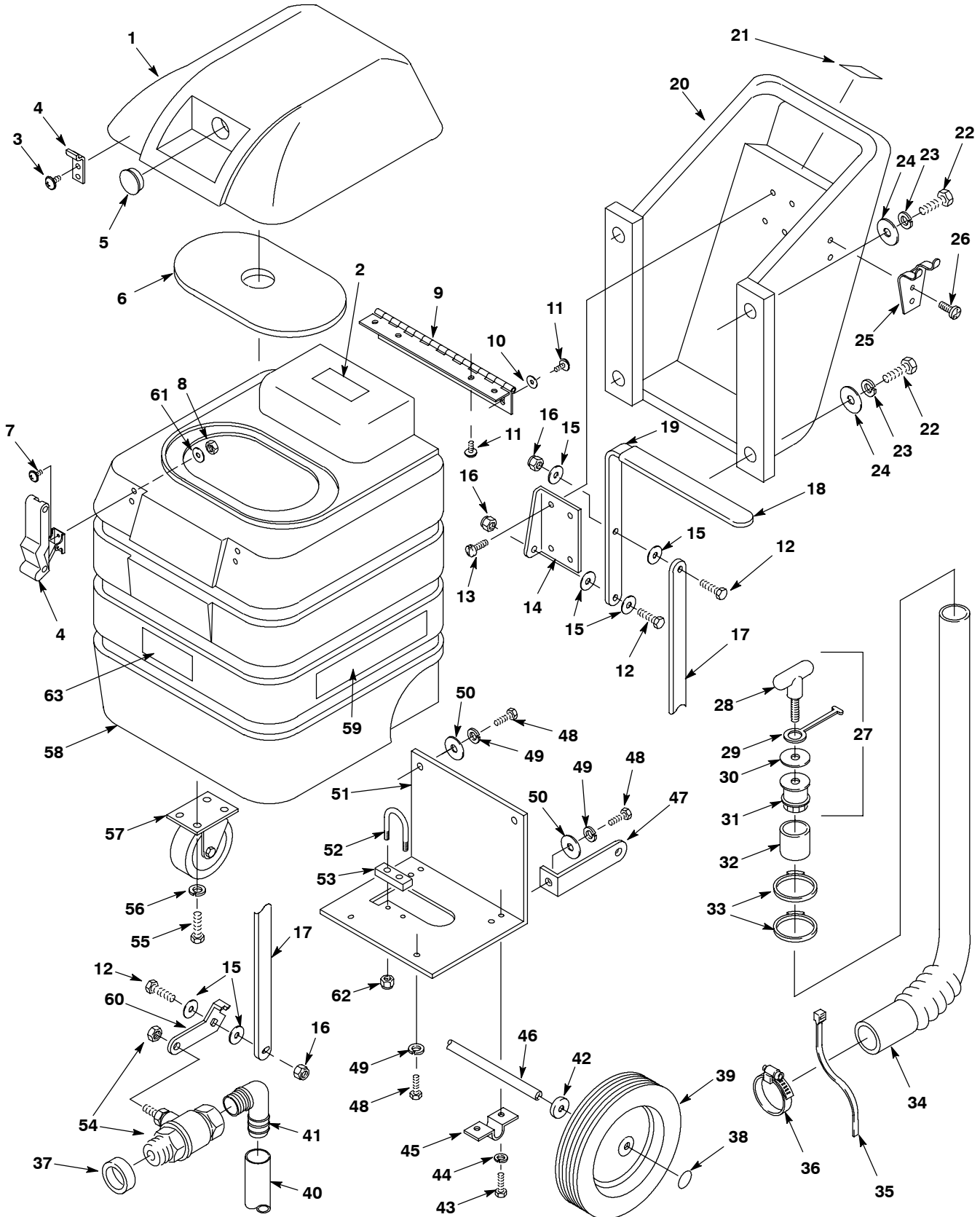

MAIN HOUSING ASSEMBLY

REF	PART #	DESCRIPTION	QTY.
1	608613	COVER, GREEN	1
2	610722	LABEL, HZRD, FLAMMABLE MATL	1
3	609980	SCREW, TRS, #8-32X0.38, PHL	4
4	49800	●LATCH, HOOD RUBBER	2
5	601401	PLUG, DOME	1
6	613233	●GASKET, 16 GAL COVER	1
7	140802	SCREW, 8-32X5/8	4
8	28990	NUT, LOCK 8-32	4
9	230318	HINGE, COVER 16 GAL	1
10	140000	WASHER, FLAT 1/4"	4
11	140195	SCREW, 1/4-20X1/2	8
12	601293	SCREW, 1/4-20X.312	3
13	140825	SCREW, #6X1/2	4
14	601285	BRACKET, PIVOT MOUNT	1
15	140027	WASHER, FLAT 5/16	6
16	41169	NUT, HEX, LOCK, .25-20, NL, SS	3
17	601283	PLATE, LINK	1
18	069764052	CLOSURE, HANDLE	1
19	601284	BRACKET, HANDLE	1
20	608618	HANDLE, GREEN	1
21	1028077	LABEL, READ MANUAL, ISO	1
22	140231	SCREW, 3/8X1-1/2	4
23	140017	WASHER, SPLIT LOCK 3/8"	4
24	140028	WASHER, FLAT 3/8"	4
25	611978	BRACKET, DRAIN HOSE	1
26	140825	SCREW, #6X1/2	2
∇ 27	701061	●ASM, DRAIN HOSE STOPPER	1
▲ 28	230831	KNOB, DRAIN HOSE	1
▲ 29	230882	STRAP, DRAIN STOPPER	1
▲ 30	140056	WASHER, FNDR 3/8ID X 1.50OD	1
▲ 31	140955	PLUG, DRAIN HOSE	1
32	140921	SLEEVE, DRAIN HOSE	1

REF	PART #	DESCRIPTION	QTY.
33	140072	CLAMP	2
34	160457	●HOSE, DRAIN, 25"	1
35	130041	WIRE TIE, NYLON 11-1/2X.190	1
36	11531	CLAMP, HOSE, WORMDRIVE, 1.06-2.00D, .56W	1
37	604604	SPACER, DISPENSER, VALVE	1
38	103019	●CAP, HUB	2
39	103068	●WHEEL, 10" X 1.75 GRAY HUB/TRD	2
40	630018	●HOSE, 1.00D 0.75B 33.0L	1
41	575745	FITTING, ELBOW, .75" HOSE .75" NPT	1
42	140063	WASHER, FLAT, 0.51B 1.25D .31, NYL	2
43	01696	SCREW, .25-20X0.50	4
44	140016	WASHER, LOCK 1/4"	4
45	230746	BRACKET, AXLE OFFSET	2
46	608908	AXLE, .5D X 19.17L	1
47	230496.BK	SUPPORT, DRAIN HOSE	1
48	140885	SCREW, 1/4-20X1/2	4
49	578244000	WASHER, LOCK 1/4"	4
50	140000	WASHER, FLAT 1/4"	3
51	601292	COVER PLATE, TANK	1
52	601295	SCREW, "U" BOLT, 1/4-20X1.50ID	1
53	601282	PLATE, SPACER	1
54	601365	●VALVE BALL, 3/4" MPT X 3/4" FPT	1
55	140226	SCREW, 5/16-18X5/8	4
56	140015	WASHER, SPLIT LOCK 5/16	4
57	103065	●CASTER, SWIVEL 4"	1
58	608348	TANK, 16 GAL, GREEN	1
59	1035609	DECAL, "MONSOON"	2
60	601297	BRACKET, VALVE	1
61	140011	WASHER	4
62	41169	NUT, HEX, LOCK, .25-20, NL, SS	2
63	1034636	DECAL, NOBLES LOGO	1

- ∇ ASSEMBLY
- ▲ INCLUDED IN ASSEMBLY
- RECOMMENDED STOCK ITEM

PARTS LIST

DISPENSER ASSEMBLY

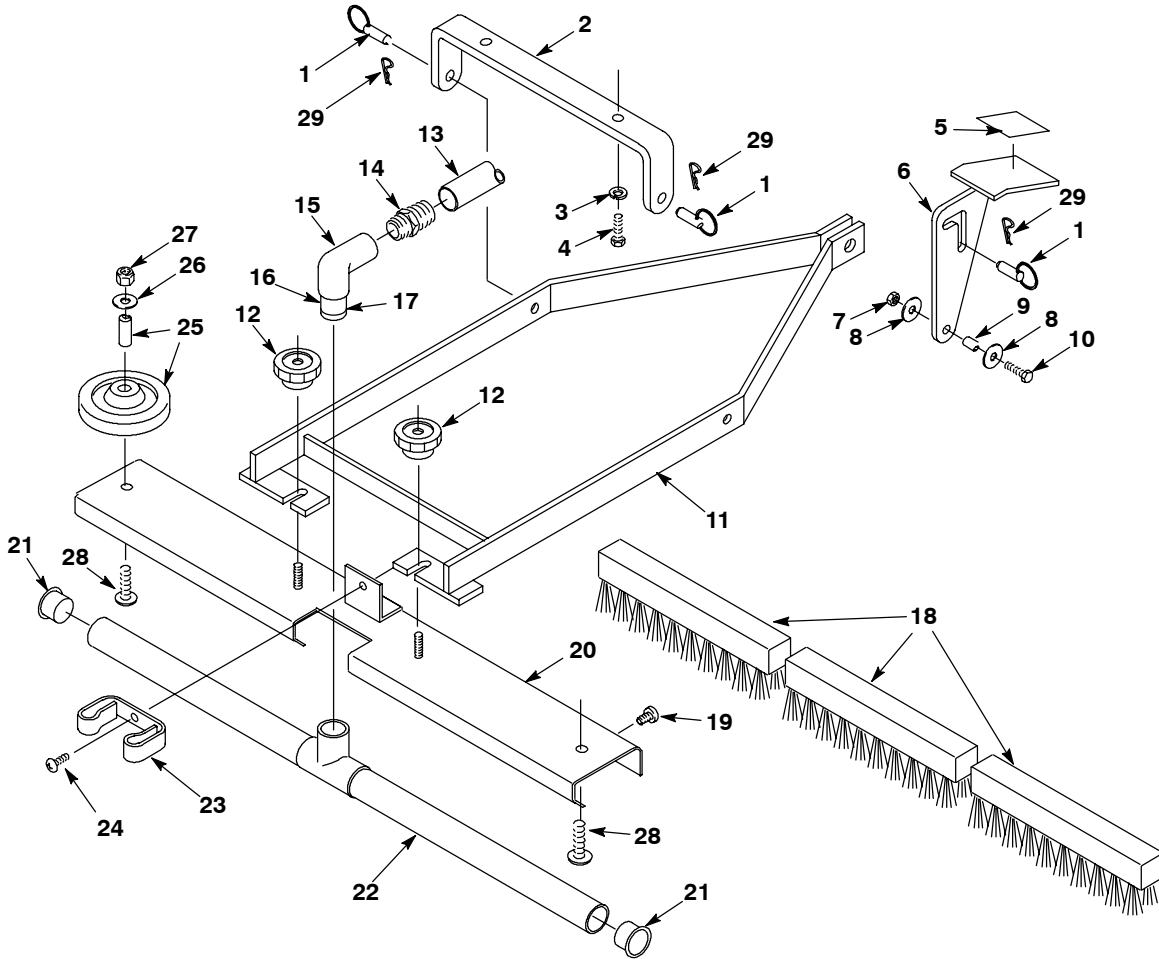

REF	PART #	DESCRIPTION	QTY.
▽	607703	ASM., 30" DISPENSER W/ BRUSH	1
▲	1	630258 PIN, CLEVIS	3
▲	2	230454 BRACKET, SQUEEGEE MOUNT	1
▲	3	140017 WASHER, SPLIT LOCK 3/8"	2
▲	4	02994 SCREW, HEX, .38-16X0.75, SS	2
▲	5	102560 PAD, NON-SLIP	1
▲	6	230456 PEDAL, LIFT	1
▲	7	59156 NUT, HEX, LOCK, .38-16, NL	1
▲	8	140028 WASHER, FLAT 3/8"	2
▲	9	140925 SPACER, CHASSIS 3/16"	1
▲	10	611048 SCREW, HEX, .38-16X1.25, SS	1
▲	11	601286 BRACKET, DISPENSER LIFT	1
▲	12	1011094 ●KNOB	2
▲	13	630018 HOSE, 1.00D 0.75B 33.0L	1
▲	14	612146000 FITTING, STR .75" HOSE, .75" NPT	1

REF	PART #	DESCRIPTION	QTY.
▲	15	601364 FITTING, 90° ELBOW 3/4"	1
▲	16	601360 CONNECTOR	1
▲	17	601361 O-RING	1
▲	18	601303 ●BRUSH, STRIP 10"	3
▲	19	140798 SCREW, 6X7/8	9
▲	20	601298 BRACKET, 30" DISPENSER ASM	1
▲	21	601363 PLUG, TAPERED	2
▲	22	601362 DISPENSER, DRIP BAR ASM 30"	1
▲	23	573073 CLIP, WAND 1" TO 1-1/2" DIA	1
▲	24	140197 SCREW, 10-24X3/8	1
▲	25	1014918AM ●WHEEL, 3.0D 0.88W 0.31B W/BSHG	2
▲	26	140027 WASHER, FLAT 5/16"	2
▲	27	28819 NUT, LOCK 5/16-18	2
▲	28	140799 SCREW	2
▲	29	612254000 PIN, HAIRPIN	3

- ▽ ASSEMBLY
- ▲ INCLUDED IN ASSEMBLY
- RECOMMENDED STOCK ITEM