

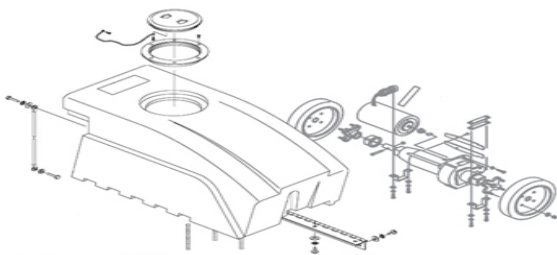

The safe scrubbing alternative®

EZ Rider™ HP

Parts Manual



FLOOREQUIPMENTPARTS.COM

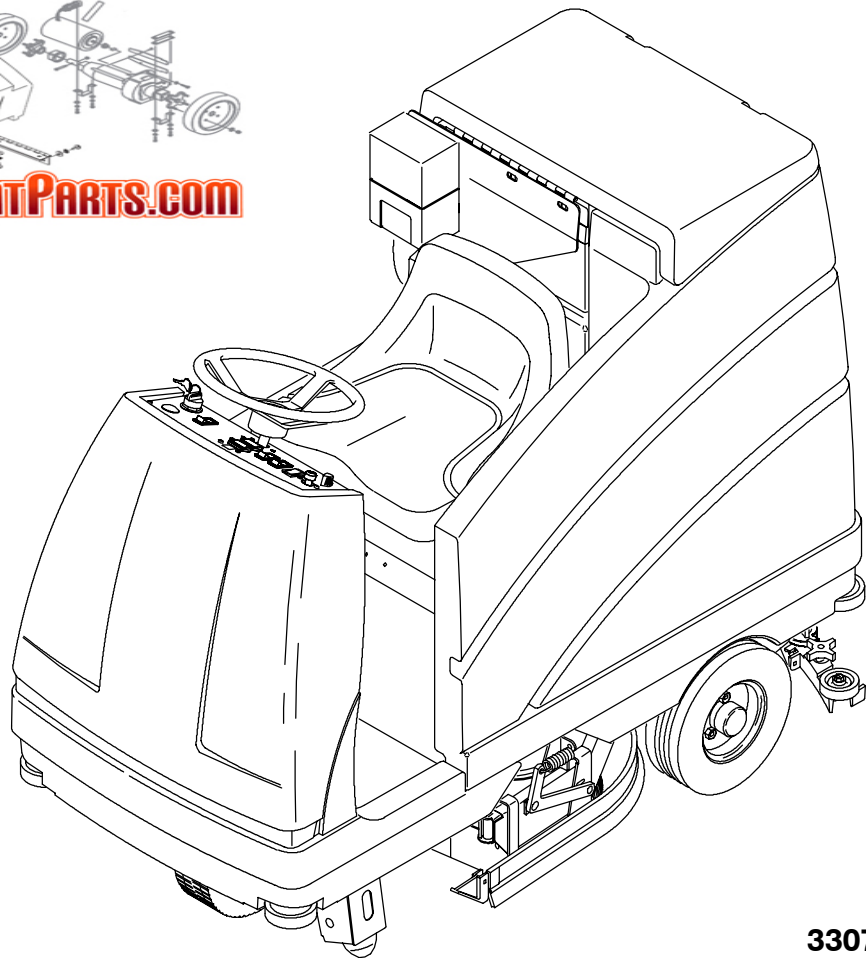

330780
Rev. 03 (02-2006)



When ordering replacement parts, use the illustrated parts list section in this manual. Before ordering parts or supplies, be sure to have your machine model number and serial number available. Parts and supplies may be ordered online, by phone, or mail from any authorized parts and service center, distributor or from any of the manufacturer's subsidiaries.

This machine will provide excellent service. However, the best results will be obtained at minimum costs if:

- The machine is operated with reasonable care.
- The machine is maintained regularly - per the maintenance instructions provided.
- The machine is maintained with manufacturer supplied or equivalent parts.

MACHINE DATA

Please fill out at time of installation for future reference.

Model No.- _____

Install. Date - _____

Serial No.- _____

MACHINE DATA PLATE

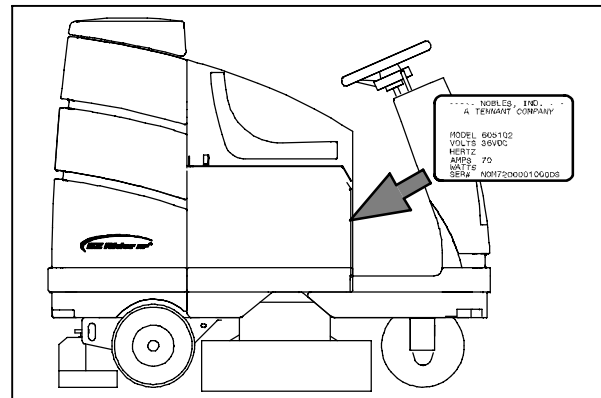

Tennant Company

PO Box 1452

Minneapolis, MN 55440

Phone: (800) 553-8033 or (763) 513-2850

www.nobles.com

The Nobles logo, the FaST Foam Scrubbing Technology logo, the "The safe scrubbing alternative" tag line, the ES logo and Quickmop are registered United States trademarks of Tennant Company.

Specifications and parts are subject to change without notice.

Copyright ©2002, 2004, 2006 Tennant Company

Printed in U.S.A.

SECTION 1

Contents	Page
Fig. 1 - General Recommended Maintenance Items	1-2
Fig. 2 - Replacement Brushes, 700 mm (28 in) .	1-4
Fig. 3 - Replacement Brushes, 800 mm (32 in) .	1-6
Fig. 4 - Main Frame Group	1-8
Fig. 5 - Seat Group	1-10
Fig. 6 - Steering Group	1-12
Fig. 7 - Instrument Panel	1-14
Fig. 8 - Controller Group	1-16
Fig. 9 - Front Drive Wheel Group	1-18
Fig. 10 - Front Brake Linkage Group (00000000-10160409)	1-20
Fig. 11 - Front Brake Linkage Group (10160410-)	1-22
Fig. 12 - Brake Pedal and Directional Pedal Group	1-24
Fig. 13 - Rear Wheel Group	1-26
Fig. 14 - Scrub Head Lift Group	1-28
Fig. 15 - Disk Scrub Head Drive Motor Group, 700 mm (28 in) (00000000-10214060)	1-30
Fig. 16 - Disk Scrub Head Drive Motor Group, 700 mm (28 in) (10214061-)	1-32
Fig. 17 - Disk Scrub Head Squeegee Group, 700 mm (28 in) (00000000-10214060)	1-34
Fig. 18 - Disk Scrub Head Squeegee Group, 700 mm (28 in) (10214061-)	1-36
Fig. 19 - Recovery Tank Group	1-38
Fig. 20 - Vacuum Fan Group	1-40
Fig. 21 - Solution Tank Group	1-42
Fig. 22 - Solution Control Group	1-44
Fig. 23 - Battery Cable Group	1-46
Fig. 24 - Rear Squeegee Lift Group	1-48
Fig. 25 - Rear Squeegee Linkage Group	1-50
Fig. 26 - Rear Squeegee Group, 700 mm (28 in)	1-52
Fig. 27 - Electrical Schematic (00000000-10143032)	1-54
Fig. 28 - Electrical Schematic (10143033-10247589)	1-55
Fig. 29 - Electrical Schematic (10247590-)	1-56
Fig. 30 - Wire Harnesses Group (00000000-10143032)	1-58
Fig. 31 - Wire Harnesses Group (10143033-10247589)	1-62
Fig. 32 - Wire Harnesses Group (10247590-)	1-66
Fig. 33 - Label Group	1-70

Fig. 1 - General Recommended Maintenance Items

Ref.	Nobles- Part No.	Description	Qty.
	390942	Blade, Sqge, Rear, 700mm	1
	390922	Blade, Sqge, Rear, 800mm	1
▽	391384	Kit, Sqge, Oil-Rstn, 700mm	1
▲	391377	Blade, Sqge, Front, 700mm, Oil-Rstn	1
▲	391378	Blade, Sqge, Rear, 700mm, Oil-Rstn	1
▽	391386	Kit, Sqge, Tile, 700mm	1
▲	390943	Blade, Sqge, Front, 700mm	1
▲	390936	Blade, Sqge, Rear, Gum Rbr, 700mm	1
▽	391383	Kit, Sqge, Oil-Rstn, 800mm	1
▲	391379	Blade, Sqge, Front, 800mm, Oil-Rstn	1
▲	391380	Blade, Sqge, Rear, 800mm, Oil-Rstn	1
▽	391385	Kit, Sqge, Tile, 800mm	1
▲	390923	Blade, Sqge, Front, 800mm	1
▲	390934	Blade, Sqge, Rear, Gum Rbr, 800mm	1
	86859	Blade Assy, Sqge, Side	2
	392842	Blade, Sqge, Lh	1
	1001290	Blade, Sqge, Rh	1
	390773	Wheel Assy, Sqge	2
	1010560	Wheel, Bmpr, 80d X 25w, Non-marking	2
	223568	Deflector, Water	2
	390633	Skirt, Front, Scb, Disk, 28 Inch	1
	390634	Skirt, Rear, Scb, Disk, 28 Inch	1
	390650	Skirt, Front, Scb, Disk, 32 Inch	1
	390651	Skirt, Rear, Scb, Disk, 32 Inch	1
	86865	Guide, Side Sqge	1
	390882	Seal, Tank, Recvy	1
	390883	Seal, Tank, Soltn	1
	390946	Hose, Vacuum	1
	391343	Seal, Fan	1
	222201	Belt, 15mm 05p 500l	1
	223569	Gasket, Shield	1
	606370	Gasket Strip	1
▽	374333	Perf Kit, Brush, Disk, 28 In	1
▲	397914	Driver Assy, Pad, 14d	2
▲	222325	Pad, Buff, 14.0d, Red	12
▲	390936	Blade, Rear, Gum Rbr, 700mm	1
▲	390943	Blade, Sqge, Front, 700mm, Linatex	1
▲	1001290	Blade, Sqge, Rh	4
▽	374334	Perf Kit, Brush, Cyc, 28 In	1
▲	222304	Brush, Scb, 28l, 18 Sr, Pyp Grout, Spl	4
▲	390936	Blade, Rear, Gum Rbr, 700mm	4
▲	390943	Blade, Sqge, Front, 700mm, Linatex	4
▲	391334	Blade Assy, Sqge, Side	4
▽	374335	Perf Kit, Brush, Disk, 32 In	1
▲	397916	Driver Assy, Pad, 16d	2
▲	63248-3	Pad, Buff, 16.0d, Red	10
▲	390934	Blade, Sqge, Rear, Gum Rbr, 800mm	2
▲	390923	Blade, Sqge, Front, 800mm, Linatex	1
▽	374336	Perf Kit, Brush, Cyl, 32 In	1
▲	222307	Brush, Scb, 32l, 18 Sr, Pyp Grout, Spl	4
▲	390936	Blade, Rear, Gum Rbr, 700mm	2
▲	390943	Blade, Sqge, Front, 700mm, Linatex	4
▲	86859	Blade Assy, Sqge, Side [Linatex]	2

▽ ASSEMBLY

▲ INCLUDED IN ASSEMBLY

Fig. 2 - Replacement Brushes, 700 mm (28 in)

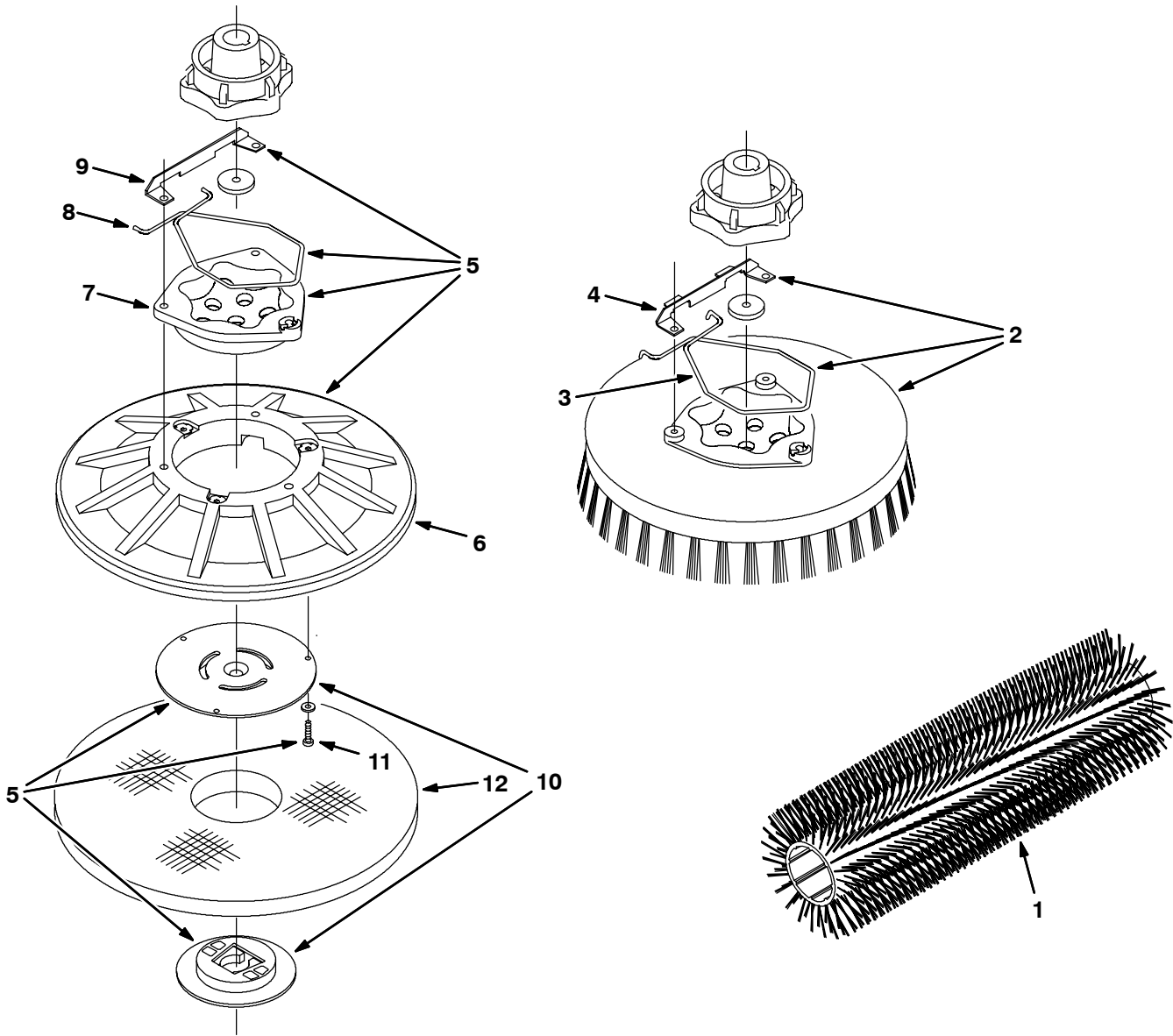

Fig. 2 - Replacement Brushes, 700 mm (28 in)

Ref.	Nobles- Part No.	Description	Qty.	
1	222304	Brush, Scb, 28l, 18 Sr, Pyp Grout, Spl	2	
1	374041	Brush, Scb, 28l, 18 Sr, Pyp, Spl	2	
1	222305	Brush, Scb, 28l, 18 Sr, Nyl, Spl	2	
1	222306	Brush, Scb, 28l, 18 Sr, Abr, Spl	2	
▽	2	222321	Brush Assy, Disk, Scb, 14.0 D, Nyl	2
▲	3	14838	Spring, Wir, 0.16d, Brush Retaining	1
▲	4	24299	Bracket, Retainer, Spring	1
▽	2	222320	Brush Assy, Disk, Scb, 14.0 D, Pyp	2
▲	3	14838	Spring, Wir, 0.16d, Brush Retaining	1
▲	4	24299	Bracket, Retainer, Spring	1
▽	2	222322	Brush Assy, Disk, Scb, 14.0 D, Super Abr	2
▲	3	14838	Spring, Wir, 0.16d, Brush Retaining	1
▲	4	24299	Bracket, Retainer, Spring	1
▽	5	397914	Driver Assy, Pad. 14D	2
▲	6	397974	Disk, Pad Driver, W/ Face, 14d	1
▲	7	15539	Adaptor, Brush	1
▲	8	14838	Spring, Wir, 0.16d, Brush Retaining	1
▲	9	24299	Bracket, Retainer, Spring	1
▲	10	370095	Device, Centering	1
▲	11	09198	Screw, Pan, M04 X 0.7 X 35, Ss	3
	12	222324	Pad, Polish, 14.0d, White	2
	12	222325	Pad, Buff, 14.0d, Red	2
	12	222326	Pad, Scrub, 14.0d, Blue	2
	12	222327	Pad, Strip, 14.0d, Brown	2
	12	370091	Pad, Strip Hd, 14.0d, Black	2

▽ ASSEMBLY

▲ INCLUDED IN ASSEMBLY

Fig. 3 - Replacement Brushes, 800 mm (32 in)

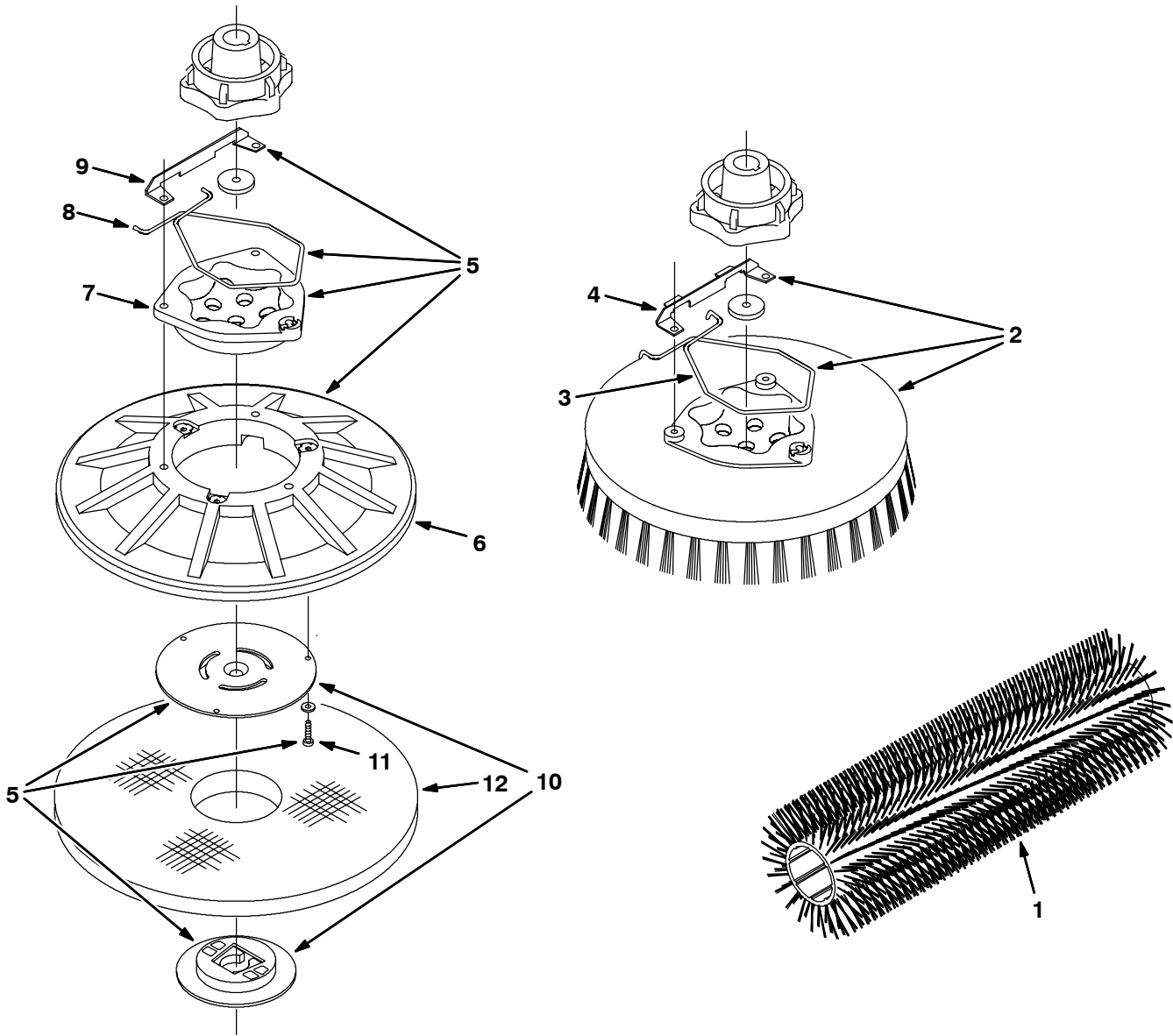

Fig. 3 - Replacement Brushes, 800 mm (32 in)

Ref.	Nobles- Part No.	Description	Qty.	
1	222307	Brush, Scb, 32l, 18 Sr, Pyp Grout, Spl	2	
1	374042	Brush, Scb, 32l, 18 Sr, Pyp, Spl	2	
1	222308	Brush, Scb, 32l, 18 Sr, Nyl, Spl	2	
1	222309	Brush, Scb, 32l, 18 Sr, Abr, Spl	2	
▽	2	05724	Brush Assy, Disk, Scb, 16.0 D, Nyl	2
▲	3	14838	Spring, Wir, 0.16d, Brush Retaining	1
▲	4	24299	Bracket, Retainer, Spring	1
▽	2	30241	Brush Assy, Disk, Scb, 16.0 D, Pyp	2
▲	3	14838	Spring, Wir, 0.16d, Brush Retaining	1
▲	4	24299	Bracket, Retainer, Spring	1
▽	2	05726	Brush Assy, Disk, Scb, 16.0 D, Super Abr	2
▲	3	14838	Spring, Wir, 0.16d, Brush Retaining	1
▲	4	24299	Bracket, Retainer, Spring	1
▽	5	397916	Driver Assy, Pad. 16D	2
▲	6	397976	Disk, Pad Driver, W/ Face, 16d	1
▲	7	15539	Adaptor, Brush	1
▲	8	14838	Spring, Wir, 0.16d, Brush Retaining	1
▲	9	24299	Bracket, Retainer, Spring	1
▲	10	370095	Device, Centering	1
▲	11	09198	Screw, Pan, M04 X 0.7 X 35, Ss	3
	12	63248-1	Pad, Strip, 16.0d, Brown	2
	12	63248-2	Pad, Scrub, 16.0d, Blue	2
	12	63248-3	Pad, Buff, 16.0d, Red	2
	12	63248-4	Pad, Polish, 16.0d, White	2
	12	370092	Pad, Strip Hd, 16.0d, Black	2

▽ ASSEMBLY

▲ INCLUDED IN ASSEMBLY

Fig. 4 - Main Frame Group

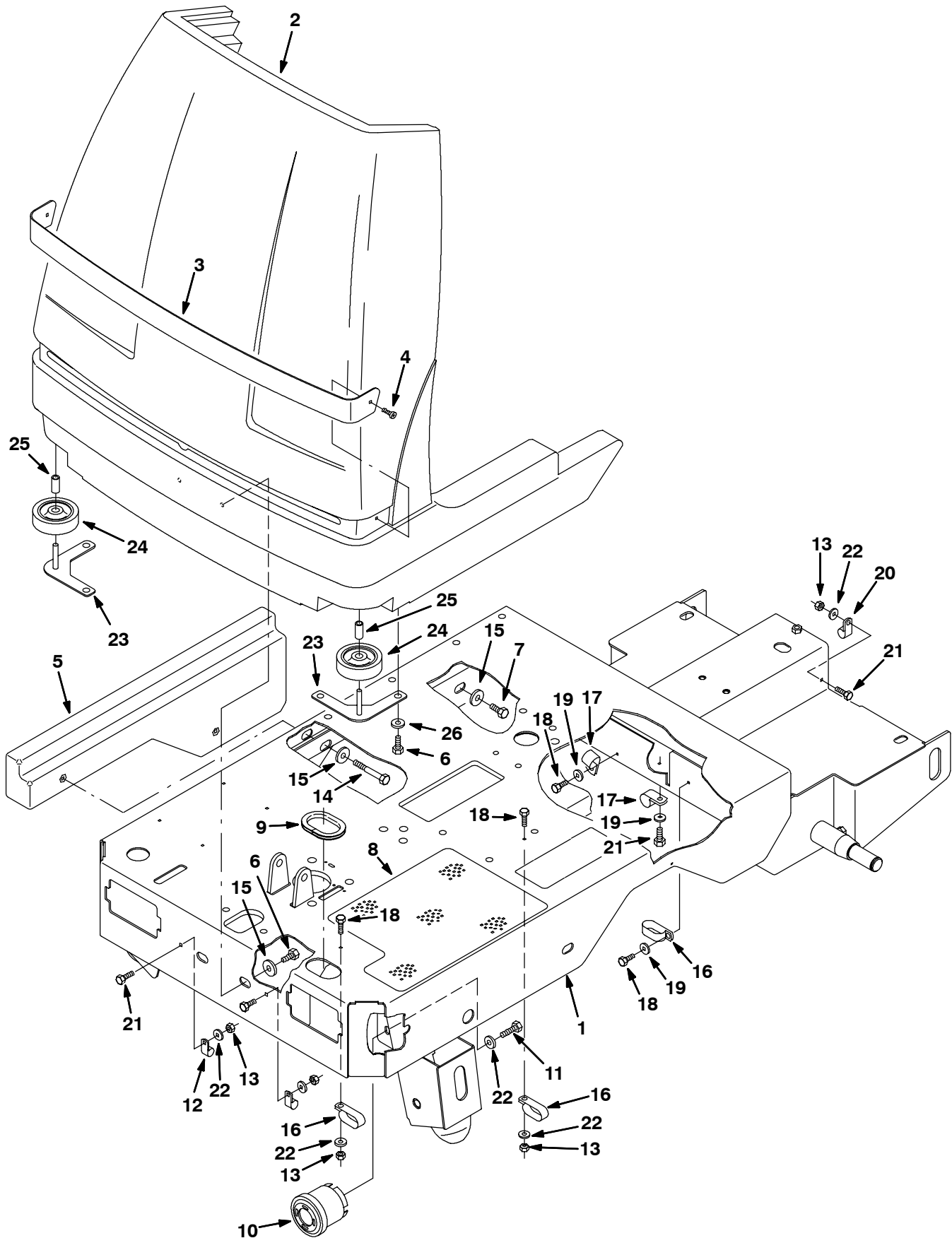

Fig. 4 - Main Frame Group

Ref.	Nobles- Part No.	Description	Qty.
1	390800	Frame Wldt, Micro Scrubber	1
2	390681	Shroud, Front, Trim	1
3	393029	Strip, Cover, Shroud, Front	1
4	360973	Screw, Pan, #12-16 X 0.50, F/ Plstc	2
5	391147	Panel, Tank, Filler, Plstc	1
6	09740	Screw, Hex, M08 X 1.25 X 20, Ss	10
7	16931	Screw, Hex, M08 X 1.25 X 20, 8.8	1
8	391304	Tread, Non-Skid, 14.0 9.6	1
9	390696	Molding, Trim, .08-.11 10.00	1
10	392937	Horn, 12-48 Vdc	1
11	01697	Screw, Hex, .25-20 X 0.62, Ss	1
12	26395-1	Clamp, Cable, Stl, 0.56d X 0.38w, 1h	2
13	08712	Nut, Hex, Lock, M06 X 1.0, NI, Ss	5
14	06957	Screw, Hex, M08 X 1.25 X 60, 8.8	1
15	13248	Washer, 0.40b 1.12d .12, Stl, PI	8
16	09570	Clamp, Cable, Stl, 0.9x1.8 X 0.88w, 1h	3
17	69234	Clamp, Cable, Stl, 1.00d X 0.75w, 1h	2
18	09007	Screw, Hex, M06 X 1.0 X 25, Ss	4
19	32483	Washer, Flt, .25 Sae	3
20	67767	Clamp, Cable, Stl, 0.69d X 0.62w, 1h	1
21	08716	Screw, Hex, M06 X 1.0 X 20, Ss	4
22	01684	Washer, Flt, .25 Ss	6
23	1007845	Plate Wldt, Mtg, Wheel	2
24	81580	Wheel, 4.0d 0.87w 0.44b	2
25	393129	Sleeve, P/M, 0.437d 0.318b 1.15l 430ss	2
26	01685	Washer, Flt, .31 Ss	4

Fig. 5 - Seat Group

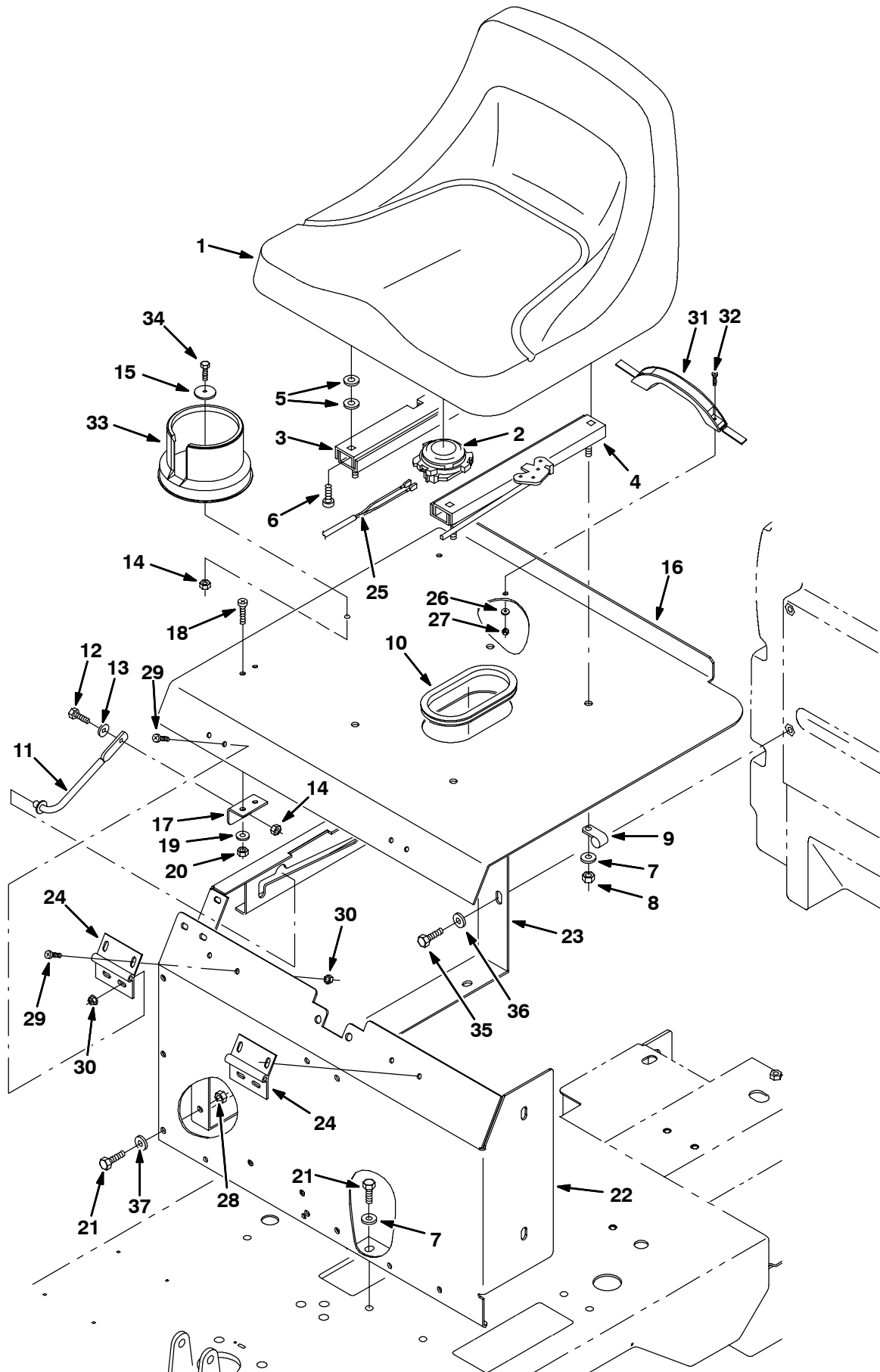

Fig. 5 - Seat Group

Ref.	Nobles- Part No.	Description	Qty.	
1	375411	Seat, Michigan, Model V-1500	1	
2	390769	Switch, Seat, Nc	1	
3	360369	Rail	1	
4	360370	Rail	1	
5	69461	Washer, 0.38b 0.88d .12, Stl, PI	8	
6	25537	Screw, Pan, .31-18 X 0.75, 2	4	
7	32491	Washer, Flt, .31 Std	10	
8	32983	Nut, Hex, Lock, .31-18, NI	4	
9	40678-1	Clamp, Cable, Stl, 0.88d X 0.62w, 1h	1	
10	390694	Molding, Trim, .08-.11 19.00	1	
11	223080	Rod Wldt, Prop	1	
12	06943	Screw, Hex, M06 X 1.0 X 20, 8.8	1	
13	32483	Washer, Flt, .25 Sae	1	
14	08708	Nut, Hex, Lock, M06 X 1.0, NI	2	
15	41178	Washer, Flat, 0.25 Fender	1	
▽	16	393130	Plate, Seat W/ Labels, Blk	1
▲	17	392846	Angle, Rod, Prop	1
▲	18	09164	Screw, Pan, M 6 X 1.0 X 20, 4.8	2
▲	19	32483	Washer, Flat, .25 Sae	2
▲	20	08708	Nut, Hex, Lock, M06 X 1.0, NI	2
	21	16931	Screw, Hex, M08 X 1.25 X 20, 8.8	9
	22	392818	Panel, Front	1
	23	392822	Support Wldt, Seat	1
	24	58484	Hinge, .25pin .12 3.0w 03.0l 4/0.28slot	2
	25	223330	Harness, Switch, Seat	1
	26	19324	Washer, Flat, #10 Sae	2
	27	06549	Nut, Hex, Lock, M05X0.8, NI	2
	28	07791	Nut, Hex, Flng, M08X1.25	3
	29	363503	Screw, Pan, M 6 X 1.0 X 12, Ss	8
	30	07790	Nut, Hex, Flng, M06 X 1.0	8
	31	382264	Handle, Hood	1
	32	06934	Screw, Pan, M 5 X 0.8 X 20, 4.8	2
	33	223599	Cup Holder	1
	34	06944	Screw, Hex, M06 X 1.0 X 25, 8.8	1
	35	12273	Screw, Hex, M08 X 1.25 X 20, Ss, NI	4
	36	13248	Washer, 0.40b 1.12d .12, Stl, PI	4
	37	32490	Washer, Flat, .25 Std	3

▽ ASSEMBLY

▲ INCLUDED IN ASSEMBLY

Fig. 6 - Steering Group

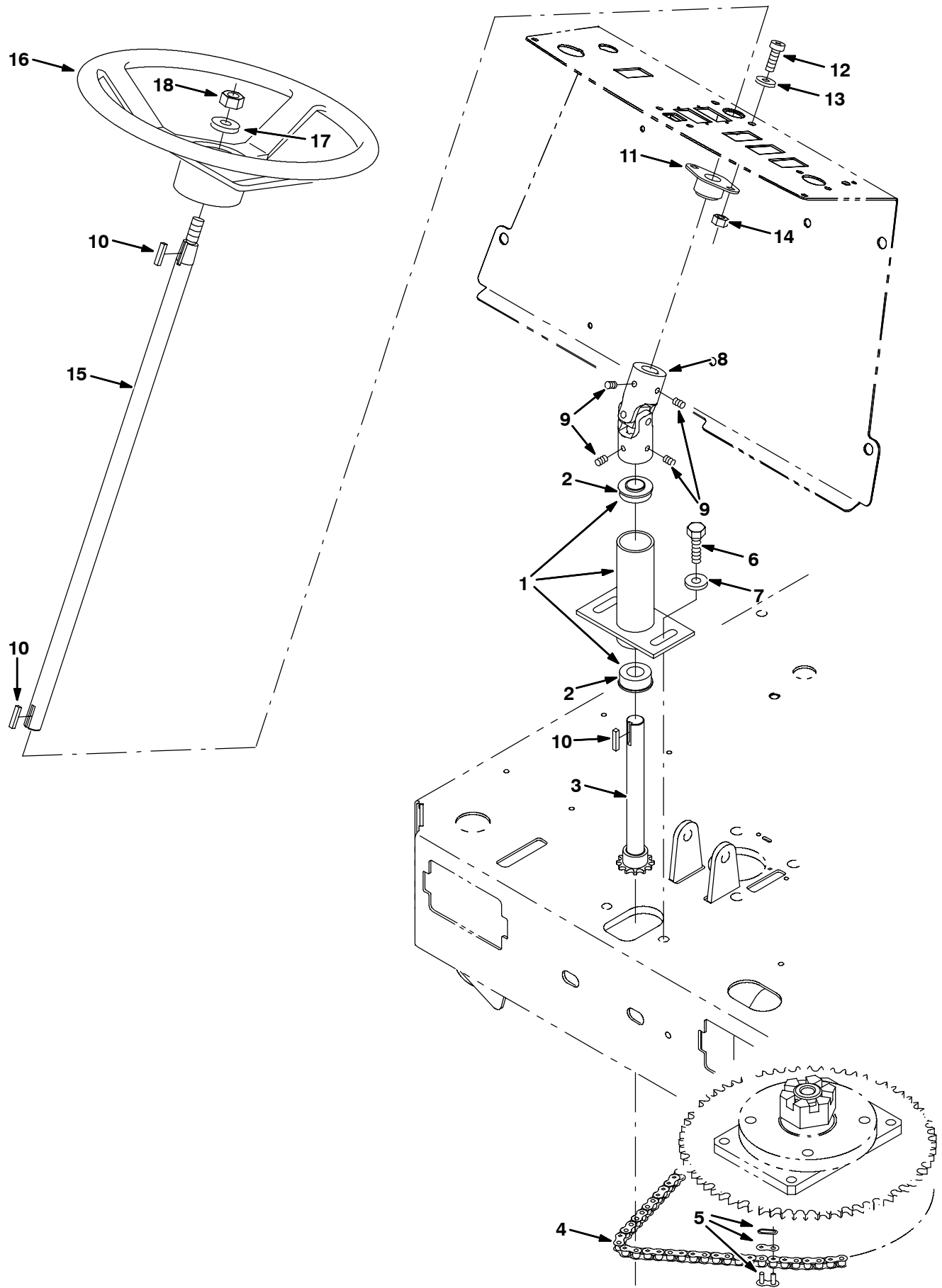

Fig. 6 - Steering Group

	Ref.	Nobles- Part No.	Description	Qty.
▽	1	391381	Housing Assy, Steering [7100/Ez Rider]	1
▲	2	223073	Bearing, Ball, 0.75b 1.38d 0.50w	2
	3	391401	Shaft, W/ Sprocket, Steering	1
	4	390788	Chain, Roller #35, .375 Pitch	1
	5	14799	Link, Chain, Roller, #35	1
	6	39284	Screw, Hex, M10 X 1.5 X 35, 8.8	2
	7	41187	Washer, Belleville, .38	2
	8	223072	Joint U	1
	9	46820	Screw, Set, .31-18 X 0.38, NI	4
	10	00912	Key, Sq, 0.19 X 0.19, 01.00l	3
	11	223065	Bushing Assy, Flng, 2 Hole, 0.75b, Nyl	1
	12	393135	Screw, Btn, M8x 1.25 X 20, Blk	2
	13	32490	Washer, Flat, .25 Std	2
	14	08709	Nut, Hex, Lock, M08 X 1.25,NI	2
	15	223061	Shaft, Steering, Upper, Mach, .75d 24.1l	1
	16	223075	Wheel, Steering, 14.0d, Taper Bore	1
	17	32493	Washer, Flt, .50 Std	1
	18	08711	Nut, Hex, Lock, M12 X 1.75,NI	1

▽ ASSEMBLY

▲ INCLUDED IN ASSEMBLY

Fig. 7 - Instrument Panel

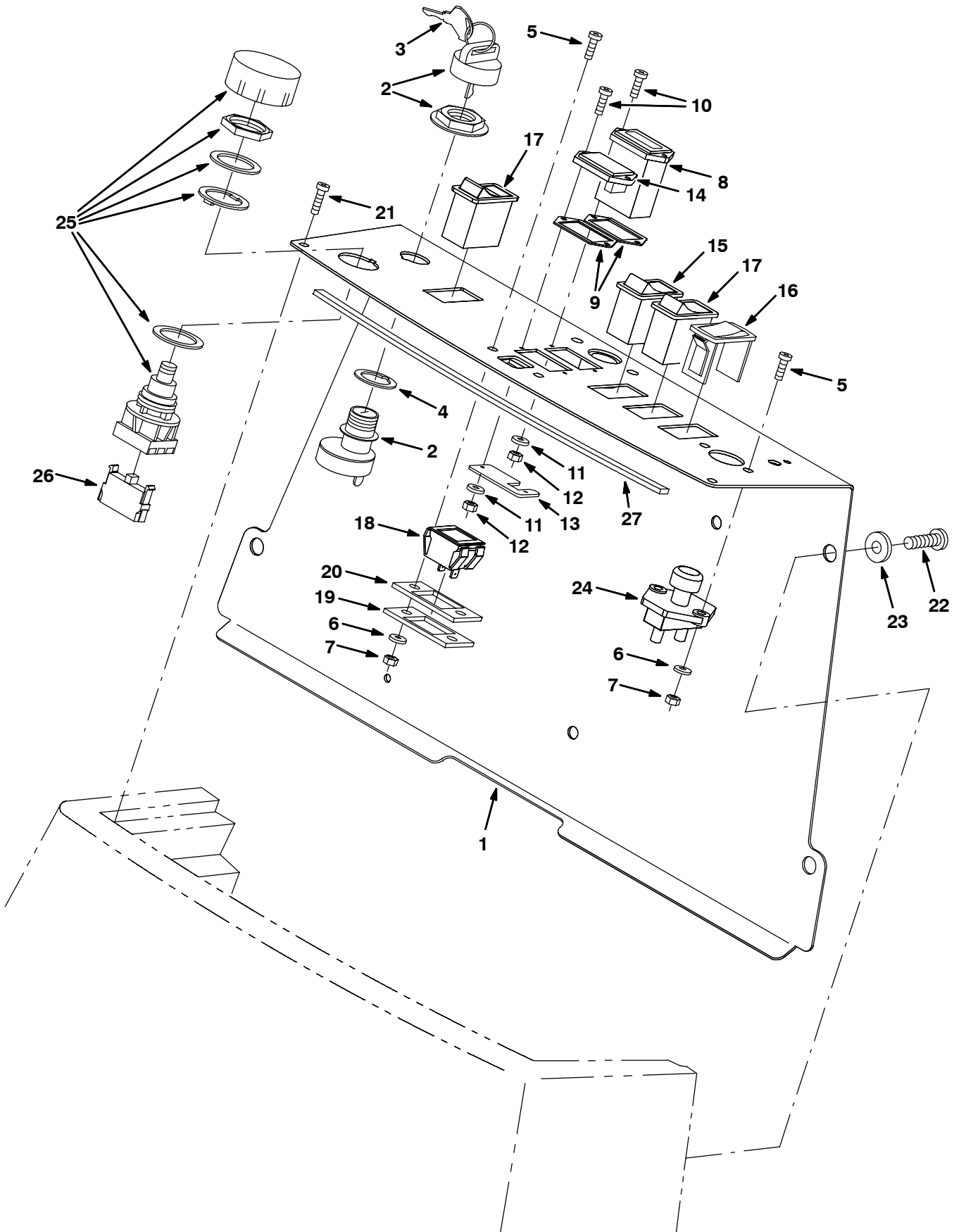

Fig. 7 - Instrument Panel

Ref.	Nobles- Part No.	Description	Qty.	
	1	392827	Panel, Instmt [Ezrider Hp/7080]	1
▽	2	392896	Switch, Key	1
▲	3	392897	Key, Replmt	1
	4	392877	Washer, Switch, Key	1
	5	393134	Screw, Btn, M6 X 1.0 X 20, Blk	4
	6	32483	Washer, Flat, .25 Sae	4
	7	08708	Nut, Hex, Lock, M06 X 1.0, NI	4
	8	377433	Gauge, Hourmeter, 12-80 VDC Analog	1
	9	222683	Gasket, Hourmeter	2
	10	09146	Screw, Pan, M03 X 0.5 X 12, 4.8	4
	11	39658	Washer, Lock, Int, #04	4
	12	01754	Nut, Hex, Std, M03 X 0.5	4
	13	393112	Plate, Sppt, Gauge, Battery	1
	14	392894	Gauge, Battery	1
	15	392171	Switch, Rocker, 36vdc, 05a Dpst On/Off/On	1
	16	398501	Switch, Rocker, Hole Plug	1
	17	397889	Switch, Rocker, Dpst	2
	18	361074	Light, Panl, 36vdc, 1.1 X 1.0	1
	19	392838	Plate, Mtg, Light	1
	20	392839	Seal, Foam	1
	21	360973	Screw, Pan, #12-16 X 0.50, F/Plstc	2
	22	09740	Screw, Pan, M08 X 1.25 X 20, 4.8	4
	23	01685	Washer, Flat, .31 Ss	4
	24	44078	Switch, Push, 12vdc 80a Spst No	1
	25	78553	Switch	1
	26	393170	Contact, Switch	1
	27	606370	Gasket Strip	1

▽ ASSEMBLY

▲ INCLUDED IN ASSEMBLY

Fig. 8 - Controller Group

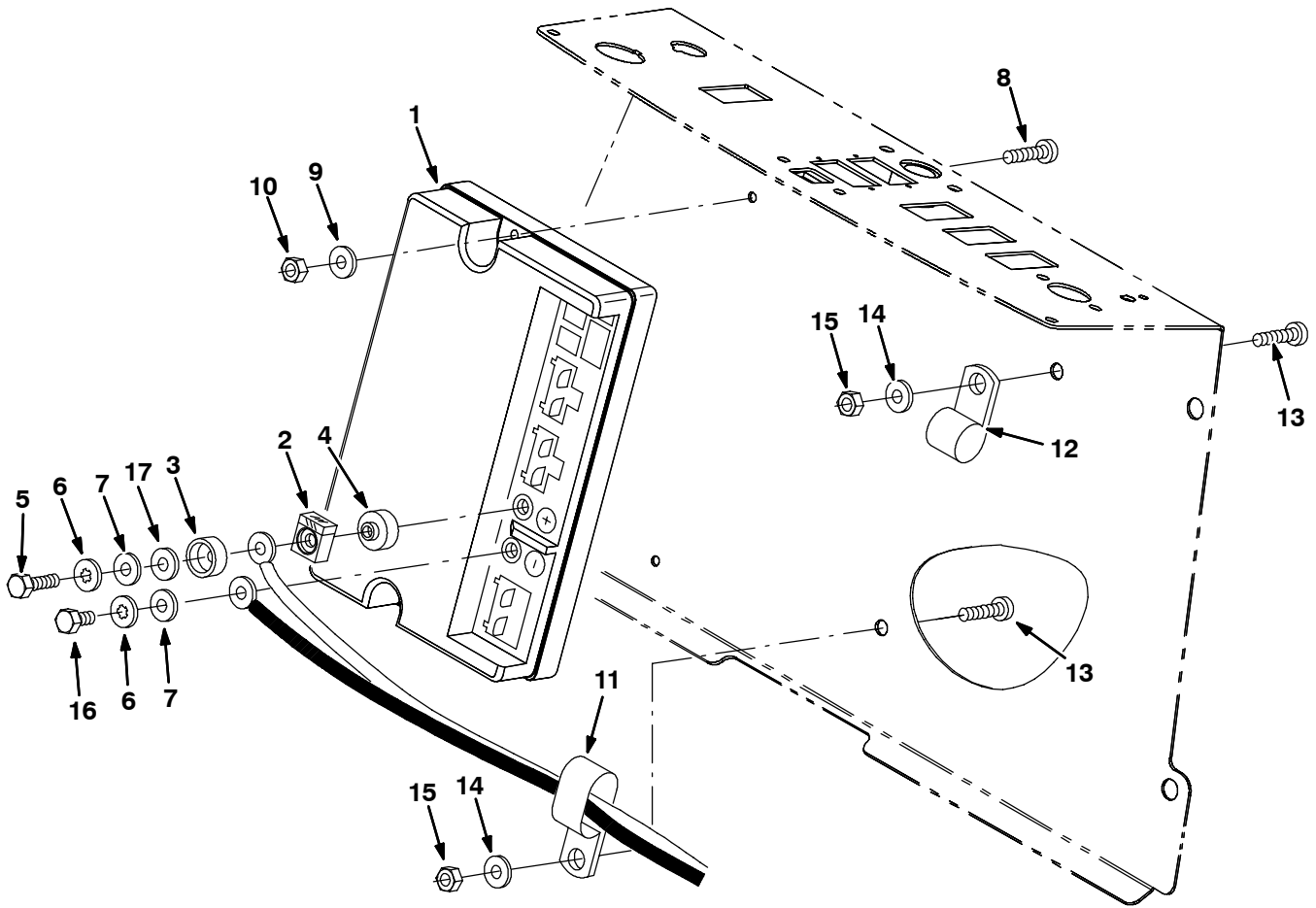

Fig. 8 - Controller Group

Ref.	Nobles- Part No.	Description	Qty.
1	1016832	Controller, Mach	1
2	392895	Fuse, 125 Amp, 58vdc	1
3	1002672	Insulator, Mtg, Fuse	1
4	1005650	Sleeve, Fuse, Controller	1
5	06945	Screw, Hex, M06 X 1.0 X 30, 8.8	1
6	32982	Washer, Lock, Int, .25	2
7	32483	Washer, Flat, .25 Sae	2
8	06937	Screw, Pan, M05 X 0.8 X 35, 4.8	2
9	19324	Washer, Flat, #10 Sae	2
10	06549	Nut, Hex, Lock, M05 X 0.8, NI	2
11	09570	Clamp, Cable, Stl, 0.9x1.8 X 0.88w, 1h	1
12	69234	Clamp, Cable, Stl, 1.00d X 0.75w, 1h	1
13	393135	Screw, Btn, M8x 1.25 X 20, Blk	2
14	32490	Washer, Flat, .25 Std	2
15	08709	Nut, Hex, Lock, M08 X 1.25,NI	2
16	87308	Screw, Hex, M06 X 1.0 X 12, 8.8	1
17	32483	Washer, Flat, .25 Sae (Non-FaST Models Only)	1

Fig. 9 - Front Drive Wheel Group

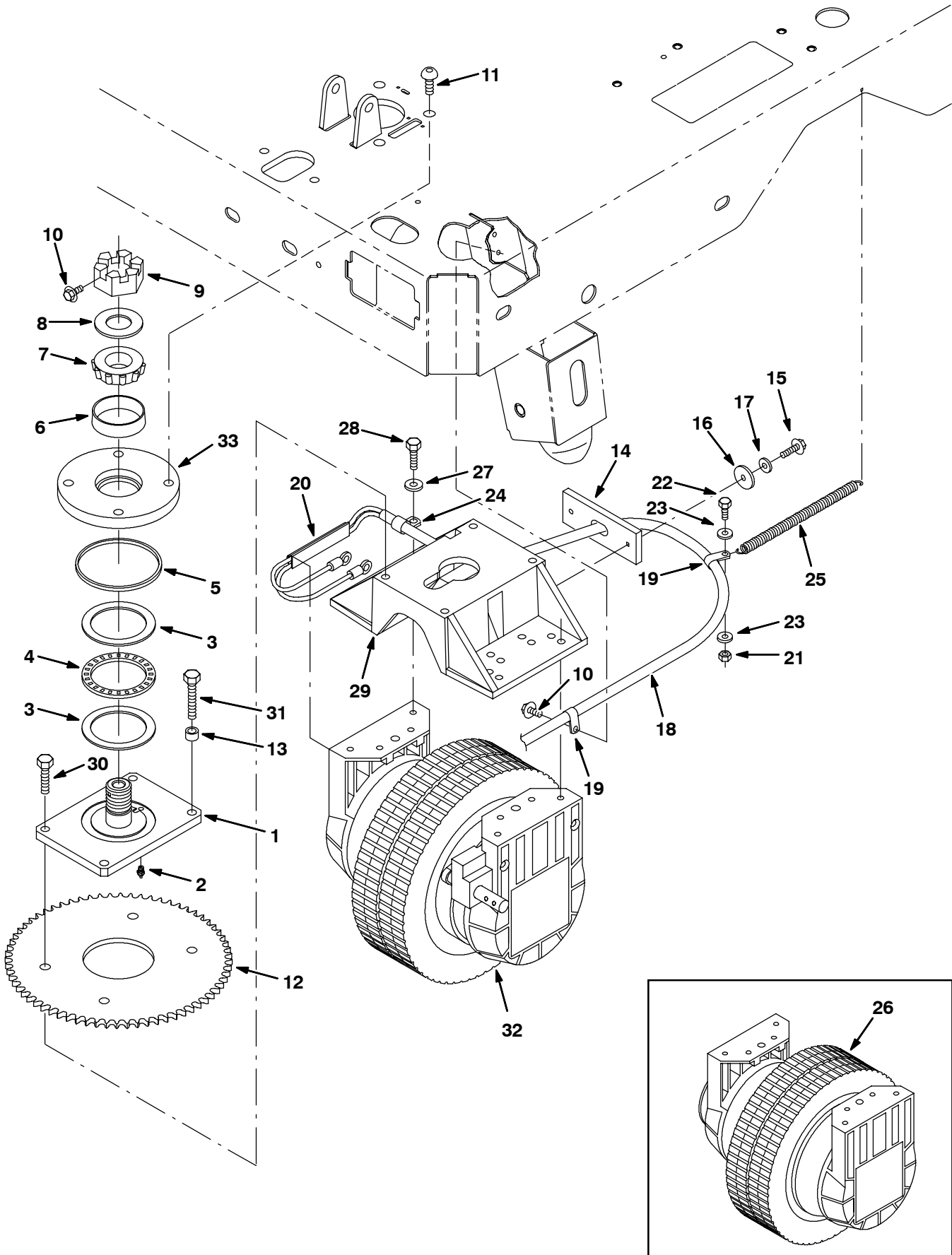

Fig. 9 - Front Drive Wheel Group

Ref.	Nobles- Part No.	Description	Qty.	
	1	390855	Plate Wldt, Swivel	1
	2	07259	Fitting, Grease, Str Pm04 .47l	1
▽		374299	Bearing Kit, Front Drive Wheel, Replmnt	2
▲	3	223161	Washer, Thrust	2
▲	4	223154	Bearing, Thrust, 2.75b 3.63d 0.13w	1
▲	5	223160	Seal, Felt, .19th, 4.3d 04.0h	1
▲	6	24989	Bearing, Cup	1
▲	7	49225	Bearing Assy, Cup/Cone	1
	8	223153	Washer	1
	9	223159	Nut, Hex, Sstd, 1.25-12	1
	10	361339	Screw, Hex, M06 X 1.0 X 16, Fmg	2
	11	83097	Screw, Btn, M12 X 1.75 X 25, 10.9 NI	4
	12	390785	Sprocket, Steering, Drive	1
	13	390879	Spacer, .41b X .63od X .38l	1
	14	1001959	Flap, Strainrelief	1
	15	222159	Screw, Hex, M06 X 1.0 X 25, Fmg	2
	16	32490	Washer, Flat, .25 Std	2
	17	41178	Washer, Flat, 0.25 Fender	2
	18	392892	Harness, Wire, Traction Motor	1
	19	26395-1	Clamp, Cable, Stl, 0.56d X 0.38w, 1h	2
	20	391300	Duct, Pvc, 0.40 X 0.75 0.40l	1
	21	08712	Nut, Hex, Lock, M06 X 1.0, NI, Ss	1
	22	15678	Screw, Hex, M06 X 1.0 X 16, Ss	1
	23	32483	Washer, Flt, .25 Sae	2
	24	67767	Clamp, Cable, Stl, 0.69d X 0.62w, 1h	1
	25	22298	Spring, Extn, 0.50od X 0.05wir, 8.0l	1
	26	390851	① Gearbox, Wheel, Front, 250mm (See Breakdowns)	1
	27	01685	Washer, Flt, .31 Ss	6
	28	222504	Screw, Hex, M08 X 1.25 X 55, Ss	6
	29	390848	Plate, Adapter, Wheel	1
	30	06962	Screw, Hex, M10 X 1.5 X 45, 8.8	3
	31	16930	Screw, Hex, M10 X 1.5 X 50, 8.8	1
	32	1007541	② Gearbox, Wheel, 250mm, 36vdc Band Brake (See Breakdowns)	1
		374346	③ Gearbox, Wheel, 250mm, 36vdc Band Brake (See Breakdowns)	1
	33	223157	Plate, Swivel, Bottom	1

① Serial number (10046634-10160409)

② Serial number (10160410-10262871)

③ Serial number (10262872-)

▽ ASSEMBLY

▲ INCLUDED IN ASSEMBLY

Fig. 10 - Front Brake Linkage Group (00000000-10160409)

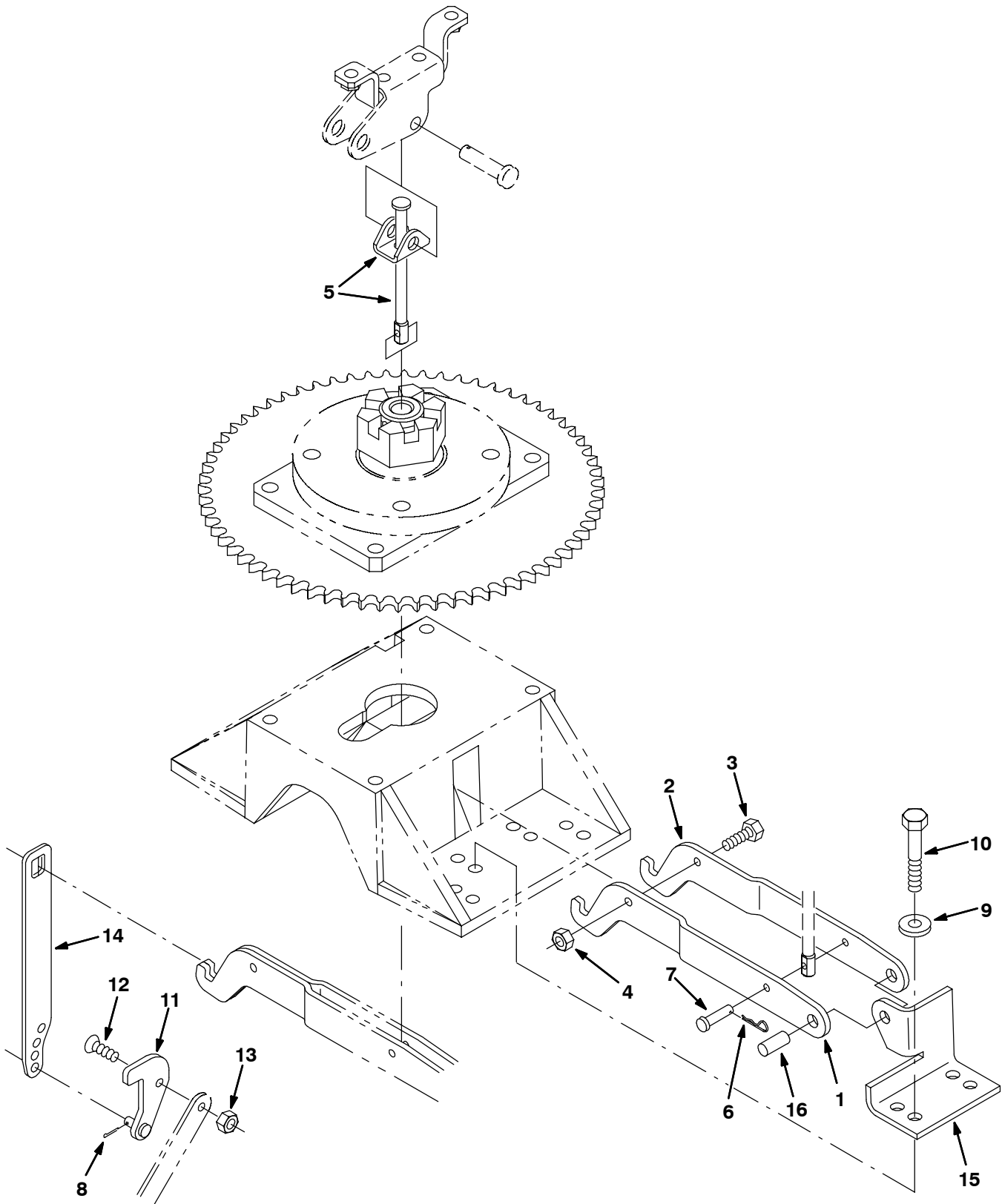

Fig. 10 - Front Brake Linkage Group (00000000-10160409)

Ref.	Nobles- Part No.	Description	Qty.
1	390892	☐ Arm, Link, Brake, Lh	1
2	390893	☐ Arm, Link, Brake, Rh	1
3	08716	☐ Screw, Hex, M06 X 1.0 X 20, Ss	1
4	08712	☐ Nut, Hex, Lock, M06 X 1.0, NI, Ss	1
5	377411	☐ Linkage Kit, Brake, Replmt.	1
6	86866	☐ Pin, Hair, Cotter, 0.38d .072wir	1
7	36191	☐ Pin, Clevis, 0.19 D X 1.00l	1
8	08170	☐ Pin, Cotter, .062 X 0.50	1
9	01685	☐ Washer, Flt, .31 Ss	2
10	06957	☐ Screw, Hex, M08 X 1.25 X 60, Ss	2
11	390895	☐ Arm Wldt, Brake	1
12	09062	☐ Screw, Flat, M06 X 1.0 X 16, 10.9	1
13	08708	☐ Nut, Hex, Lock, M06 X 1.0, NI	1
14	392968	☐ Link, Brake	1
15	390856	☐ Bracket, Brake, Pivot	1
16	390857	☐ Pin, Brake	1

☐ Serial number (10046634-10160409)

STANDARD PARTS

Fig. 11 - Front Brake Linkage Group (10160410-

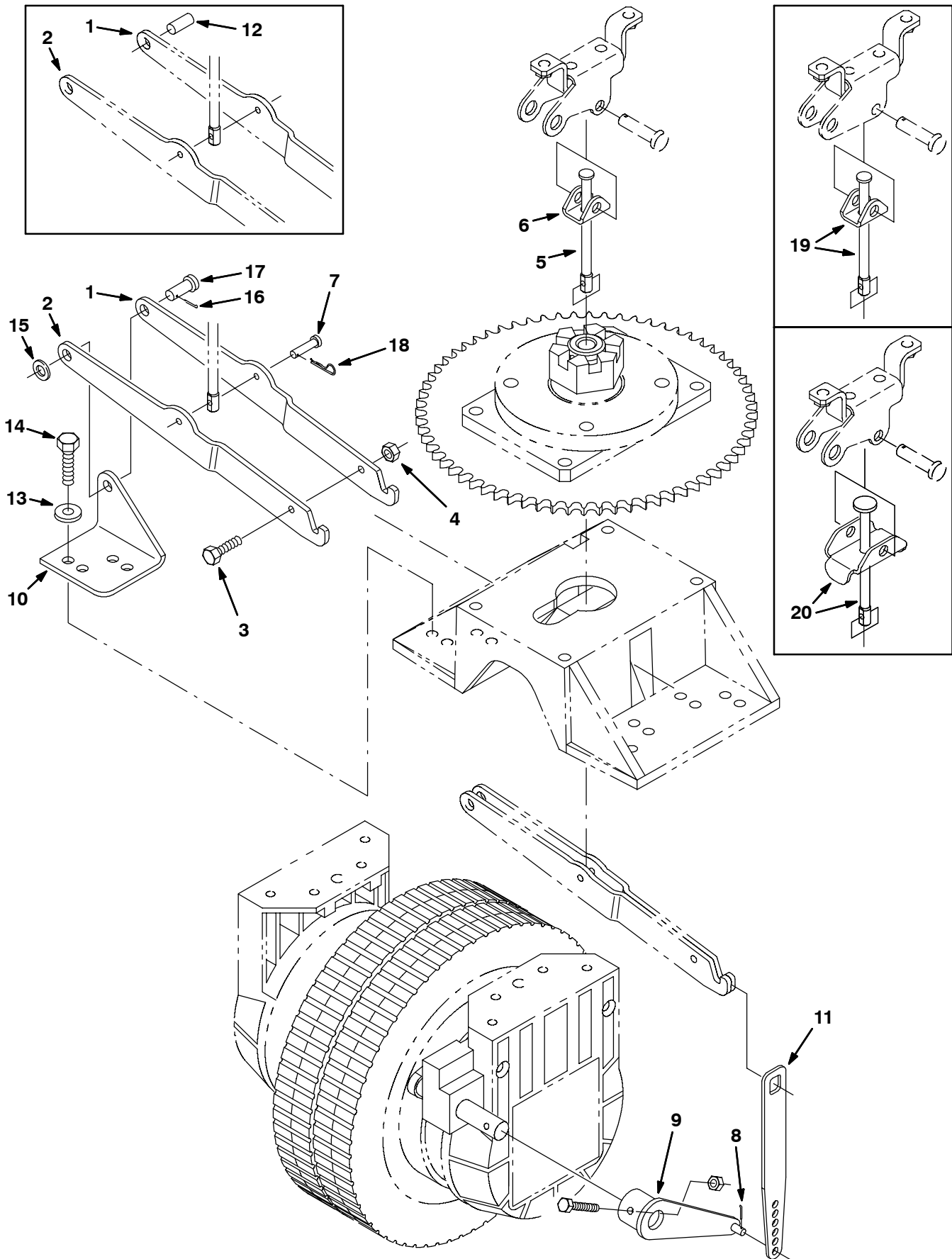

Fig. 11 - Front Brake Linkage Group (10160410-)

Ref.	Nobles- Part No.	Description	Qty.
1	1017440	② Arm, Link, Brake, Lh	1
2	1017439	② Arm, Link, Brake, Rh	1
3	08716	② Screw, Hex, M06 X 1.0 X 20, Ss	1
4	08712	② Nut, Hex, Lock, M06 X 1.0, NI, Ss	1
5	1026028	⑦ Link, Brake	1
6	1026017	⑦ Channel, Brake	1
7	36191	② Pin, Clevis, 0.19 D X 1.00l	1
8	08170	② Pin, Cotter, .062 X 0.50	2
9	1002522	② Arm Wldt, Brake	1
10	1002536	② Bracket, Brake, Pivot	1
11	1002537	② Link, Brake	1
12	86240	③ Pin, Clevis, 0.38 D X 1.13l	1
13	01685	② Washer, Flt, .31 Ss	2
14	06957	② Screw, Hex, M8 X 1.25 X 60, 8.8	2
15	32492	④ Washer	1
16	08182	④ Pin, Cotter, .125 X 1.00	1
17	140608	④ Pin, Clevis, 0.38d X 1.25l	1
18	86866	② Pin, Hair, Cotter, 0.38d .072wir	1
19	377411	⑤ Linkage Kit, Brake, Replmt	1
20	377411	⑥ Linkage Kit, Brake, Replmt	1

② Serial number (10160410-)

③ Serial number (10160410-10235461)

④ Serial number (10235462-)

⑤ Serial number (10160410-10230074)

⑥ Serial number (10230075-10251077)

⑦ Serial number (10251078-)

Fig. 12 - Brake Pedal and Directional Pedal Group

Ref.	Nobles- Part No.	Description	Qty.	
1	1006723	Pedal Wldt, Brake	1	
2	51109	Pad	1	
3	363981	Spring, Extn, 0.50od X 0.04wir, 3.0l	1	
4	374225	Pin, Clevis, 0.50 D X 3.75l	1	
5	32486	Washer, Flt, .50 Sae	2	
6	08182	Pin, Cotter, .125 X 1.00	1	
7	392966	Channel Wldt, Mtg, Spring	1	
8	1019764	③ Bracket, Channel, Mtg, Brake	1	
9	81672	Spring, Cmpr, .37id X Flat Wir 1.0l	2	
10	16213	Bolt, Shld, .31d X 1.00, .25-20	2	
11	75934	Nut, Hex, Lock, .25-20, NI	2	
12	29558	Pin, Clevis, 0.37 D X 1.50l	1	
13	39005	Pin, Cotter, .094 X 0.75	1	
14	12274	Screw, Hex, M06 X 1.0 X 20, NI	2	
15	32483	Washer, Flt, .25 Sae	2	
16	83149	Pedal, Brake, Lock	1	
17	363087	Bushing, Flng, 0.44b 1.25d 0.25l	1	
18	39284	Screw, Hex, M10 X 1.5 X 35, 8.8	1	
19	32492	Washer, Flt, .38 Std	2	
20	41430	Nut, Hex, Lock, M10 X 1.5, NI	1	
21	54745	Spring, Extn, 0.38od X 0.04wir, 2.3l	1	
22	223198	Screw, Hex, M5 X 0.8 X 10, Fmg	2	
23	97031	Spring, Wir, 0.08d, Brake, Parking	1	
24	19066	Washer, Flt, #10	6	
25	09228	Screw, Hex, M04 X 0.7 X 20, 8.8	1	
26	02850	Nut, Hex, Lock, M04 X 0.7, NI	1	
27	19065	Washer, Flat, #08	1	
▽	28	223621	Pedal Assy, Foot	1
▲		9000705	Spring Kit, Pedal, Foot, Replmt	1
▲	29	385728	Sensor, Pedal Position	1
▲	30	385729	Harness, Pedal	1
▲	31	82839	Tread, Non-Skid, 02.2w 11.5l	1
	32	74455	Screw, Hex, M06 X 1.0 X 12, Fmg	4
	33	10632	Grommet, Rbr, 0.89id, F/ 1.2h, .14matl	1
	34	377411	① Linkage Kit, Brake, Replmt	1
	35	377411	② Linkage Kit, Brake, Replmt	1

① Serial number (00000000-10230074)

② Serial number (10230075-10251077)

③ Serial number (10251078-)

▽ ASSEMBLY

▲ INCLUDED IN ASSEMBLY

Fig. 13 - Rear Wheel Group

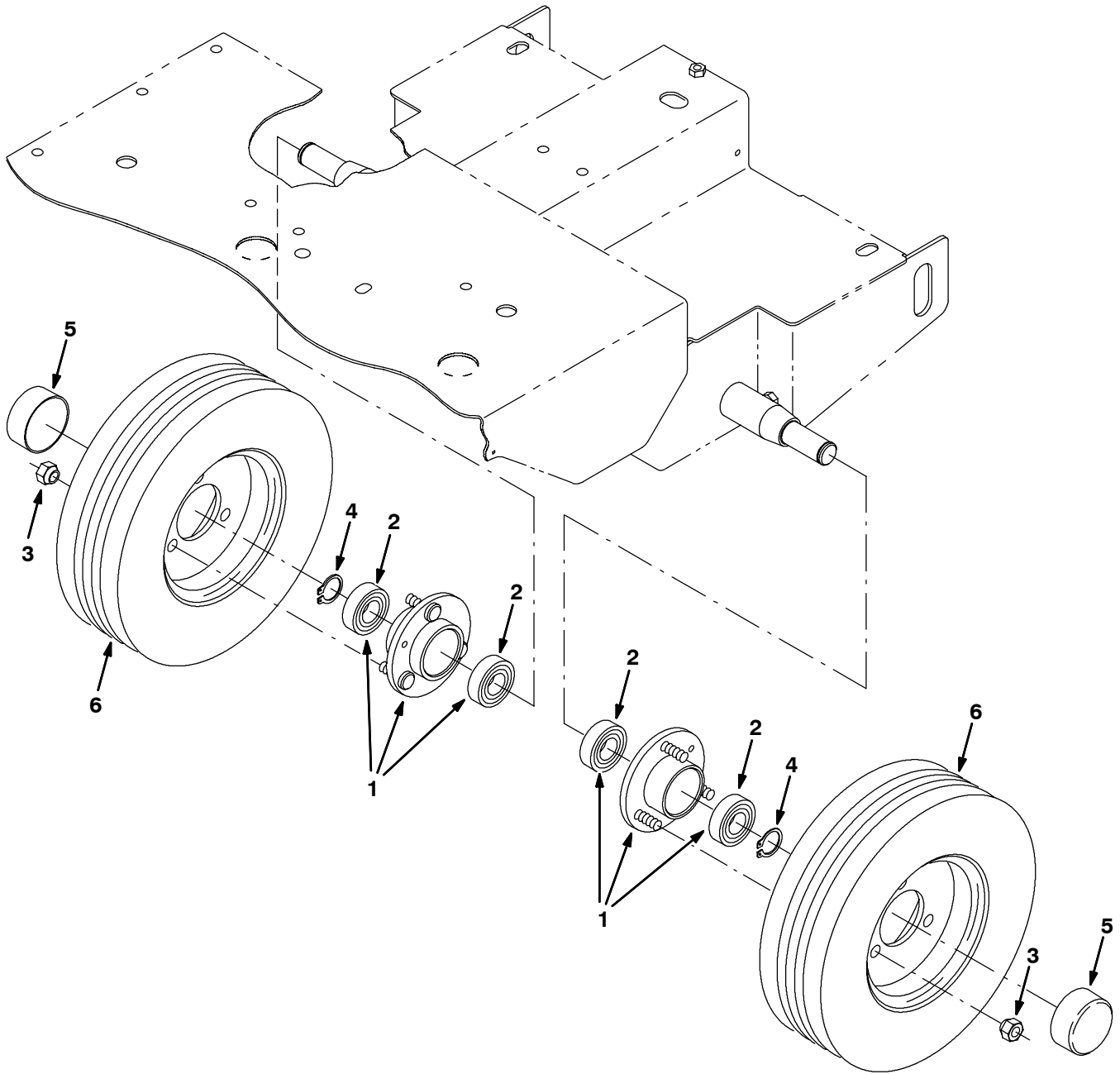

Fig. 13 - Rear Wheel Group

	Ref.	Nobles- Part No.	Description	Qty.
▽	1	391382	Housing Assy, Wheel [7100/Ez Rider]	2
▲	2	13534	Bearing, Ball, 0.98b 2.05d 0.59w	2
	3	11109	Nut, Wheel, .44-20 X 60 Angle	6
	4	09005	Ring, Retaining, Ext, 1.00d, Basic	2
	5	390905	Cap, Axle, Vyl, 02.38d	2
	6	369345	Tire Assy, Solid, 12.3x3.5 3.5bc/3bolt	2

▽ ASSEMBLY

▲ INCLUDED IN ASSEMBLY

Fig. 14 - Scrub Head Lift Group

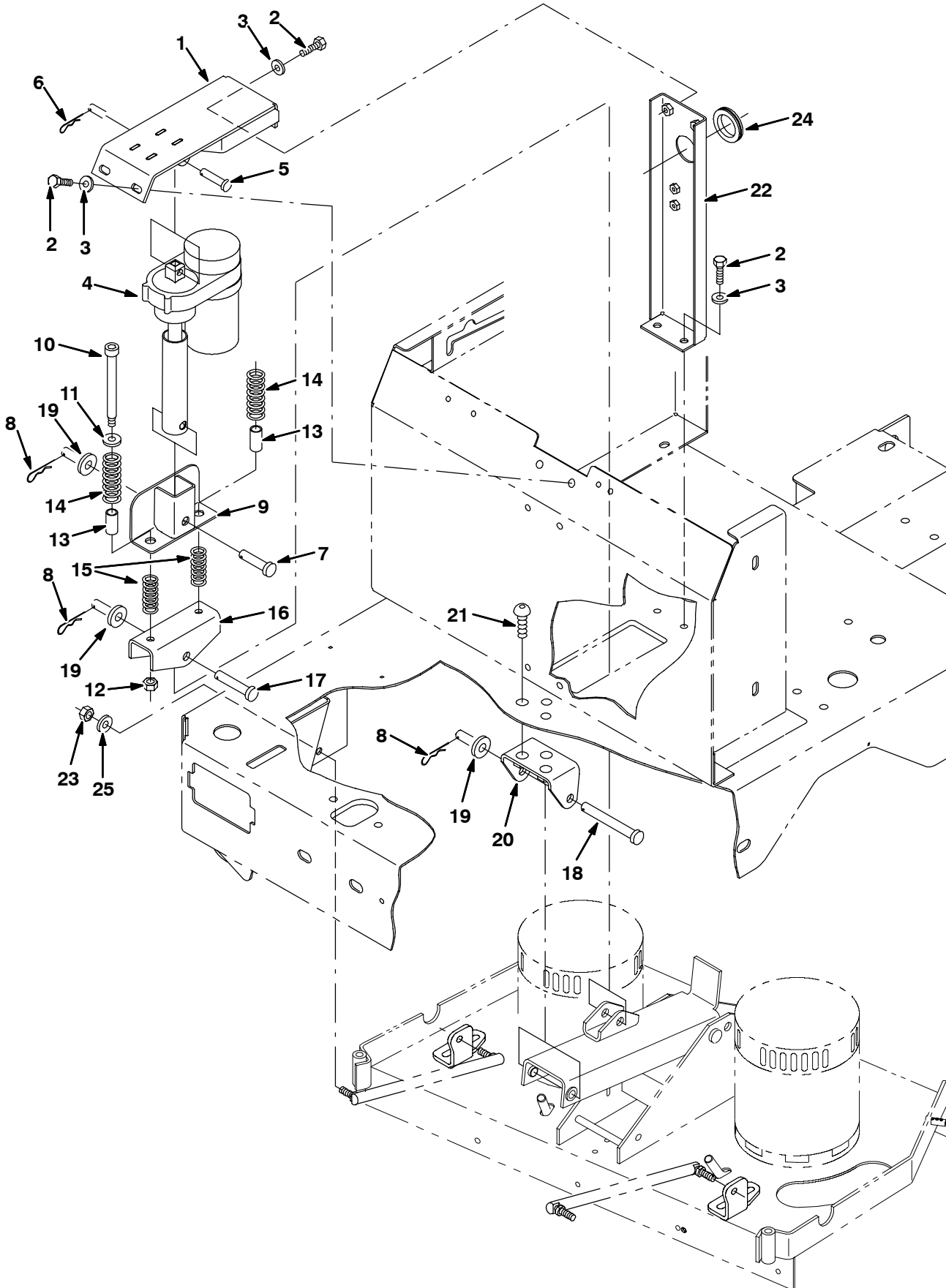

Fig. 14 - Scrub Head Lift Group

Ref.	Nobles- Part No.	Description	Qty.
1	393023	Channel Wldt, Actuator, Mtg	1
2	39277	Screw, Hex, M08 X 1.25 X 25, 8.8	6
3	32490	Washer, Flat, .25 Std	6
4	393151	Kit, Replmt, Actuator	1
5	17461	Pin, Clevis, 0.37 D X 1.75l	1
6	86866	Pin, Hair Cotter, 0.38 D .072 Wir	1
7	51534	Pin, Clevis, 0.50 D X 2.00l	1
8	02942	Pin, Hair Cotter, 0.62 D .120 Wir	3
9	392887	Bracket Wldt, Guide, Actuator	1
10	45960	Bolt, Shld, .50d X 4.25, .38-16	2
11	32486	Washer, Flt, .50 Sae	4
12	36643	Nut, Hex, Lock, .38-16, NI, Thin	2
13	50682	Sleeve, .50id X .62od X 1.31l	2
14	223518	Spring, Cmpr, 0.98od .14wir 2.5l	2
15	223517	Spring, Cmpr, 0.84od .11wir 2.0l	2
16	390665	Channel, Input, Tool, Lift	1
17	11211	Pin, Clevis, 0.50 D X 2.25l	1
18	222196	Pin, Clevis, 0.50 D X 4.00l	1
19	32486	Washer, Flat, .50 Sae	3
20	392967	Channel Wldt, Mtg, Tool, Lift	1
21	83097	Screw, Btn, M12 X 1.75 X 25, 10.9 NI	3
22	392816	Channel Wldt, Sppt	1
23	50269	① Nut, Hex, Lock, .38-24, NI, Ss	2
23	08714	② Nut, Hex, Lock, M10 x 1.5, NI, Ss	2
24	04051	Grommet, Rbr, 1.31id, F/ 1.6h, .12matl	1
25	01686	Washer, Flat, 0.44b 1.00 .08, Ss	2

① Serial number (0000000-xxxxxxx)

② Serial number (xxxxxxx-)

STANDARD PARTS

Fig. 15 - Disk Scrub Head Drive Motor Group, 700 mm (28 in)
(0000000-10214060)

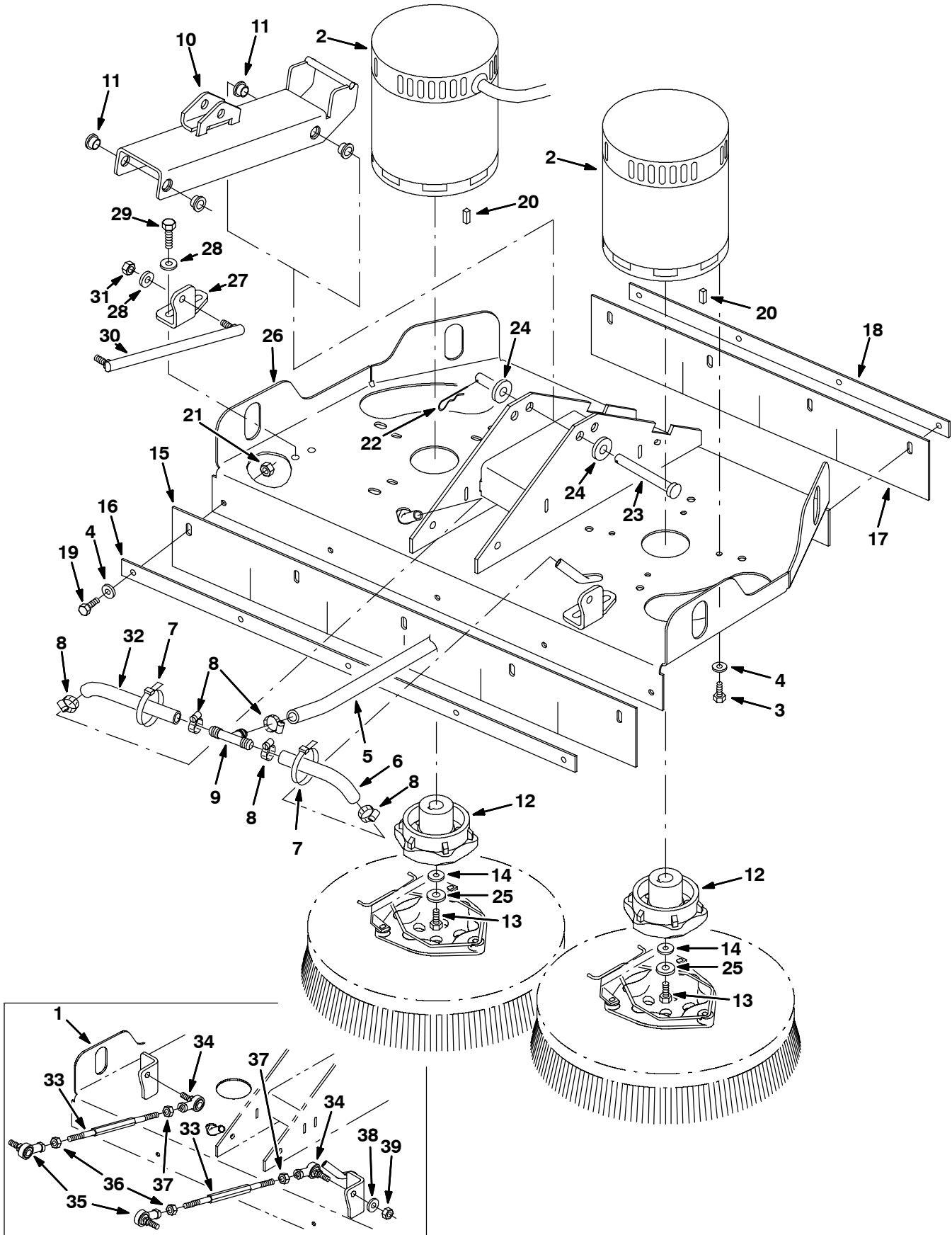

**Fig. 15 - Disk Scrub Head Drive Motor Group, 700 mm (28 in)
(00000000-10214060)**

NOTE: Disk Scrub Head Kit, Nobles Part Number 393001, includes Fig. 15 and Fig. 17.

Ref.	Nobles- Part No.	Description	Qty.
	1	393164 [1] Kit, Ci, Scrubhead, 700mm	1
▽	2	390849 Motor, Ele, 36vdc, 0.50hp, 0320rpm	2
▲		611287000 Brush Assy, Motor	1
	3	24672 Screw, Hex, .25-20 X 0.75, Ss	8
	4	01684 Washer, Flt, 25 Ss	17
	5	390933 Hose, Pvc, Brd, 0.50id (376716)	25.00'
	6	1011403 Hose, Afmkt Pvc, Brd 0.50id X 1 Ft (376716)	0.550'
	7	44961 Tie, Cable, Nyl, 14.5L .30W 4.0 Max D	2
	8	607776 Clamp Hose .73-.77 2 Wire Blk	5
	9	63245-1 Fitting, Plstc, Tee, Bm08/Bm08/Bm08	1
	10	392904 Channel Wldt, Lift Tool	1
	11	15648 Bushing, Flng, 0.50b 0.59d 0.38l	4
	12	377374 Hub, Drive, Brush, Disk, 0.75B 6T	2
	13	02991 Screw, Hex, .31-18 X 0.75, Ss	2
	14	41186 Washer, Belleville, .31	2
	15	390633 Skirt, Front, Scb, Disk, 28 Inch	1
	16	390635 Strip, Retainer, Skirt, Front, 28 Inch	1
	17	390634 Skirt, Rear, Scb, Disk, 28 Inch	1
	18	390636 Strip, Retainer, Skirt, Rear, 28 Inch	1
	19	08716 Screw, Hex, M06 X 1.0 X 20, Ss	9
	20	00926 Key, Sq, 0.25 X 0.25, 00.75l	2
	21	08712 Nut, Hex, Lock, M06 X 1.0, NI, Ss	9
	22	44906 Pin, Hair Cotter, 0.69 D .092 Wir	1
	23	222196 Pin, Clevis, 0.50 D X 4.00l	1
	24	32486 Washer, Flt, .50 Sae	2
	25	01686 Washer, Flat, 0.44b 1.00 .08, Ss	2
	26	1015950 [2] Head Wldt, Scb, Disk, 700mm	1
	27	1006123 [2] Bracket, Link, Head, Disk	2
	28	01686 [2] Washer, Flat, 0.44b 1.00 .08, Ss	6
	29	10959 [2] Screw, Hex, M10 X 1.5 X 20, SS, NL	4
	30	392882 [2] Link, Balljoint, M10 X 1.5, 11.0L	2
	31	08714 [2] Nut, Hex, Lock, M10 X 1.5, NL, SS	2
	32	1011403 Hose, Afmkt Pvc, Brd 0.50id X 1 Ft (376716)	0.550'
	33	390666 [1] Rod, Thrd, 2 End, .38-24 09.0l Lh/Rh	2
	34	86780 [1] Rod-End, .38-24lh Fem 0.38-24stud	2
	35	86781 [1] Rod-End, .38-24rh Fem 0.38-24stud	2
	36	20171 [1] Nut, Hex, Jam, .38-24	2
	37	82889 [1] Nut, Hex, Jam, .38-24, Lh	2
	38	01686 [1] Washer, Flat, 0.44b 1.00 .08, Ss	4
	39	50269 [1] Nut, Hex, Lock, .38-24, NI, Ss	4

[1] Serial number (00000000-10188432)

[2] Serial number (10188433-10214060)

▽ ASSEMBLY

▲ INCLUDED IN ASSEMBLY

STANDARD PARTS

Fig. 16 - Disk Scrub Head Drive Motor Group, 700 mm (28 in)
(10214061-)

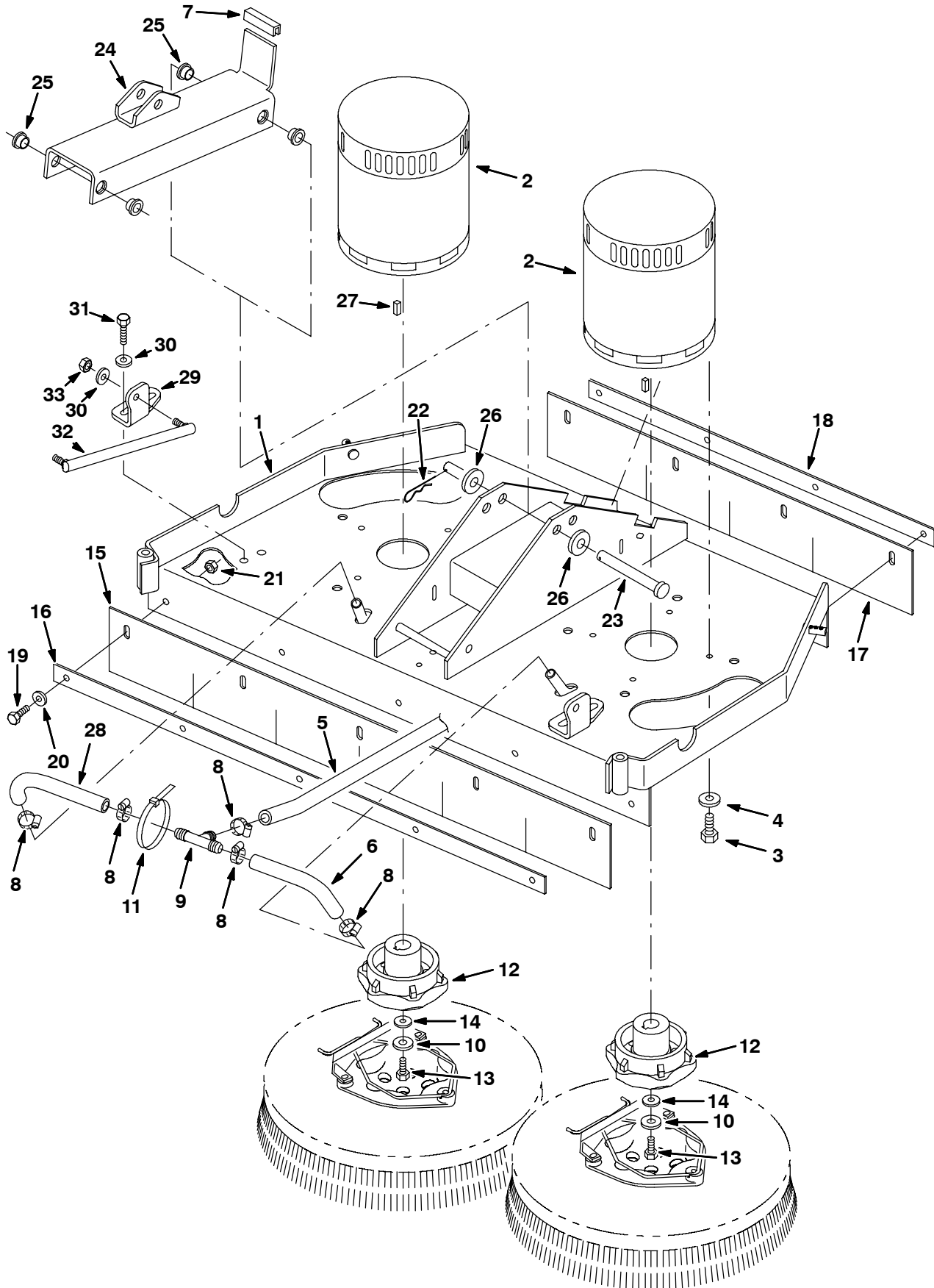

**Fig. 16 - Disk Scrub Head Drive Motor Group, 700 mm (28 in)
(10214061-)**

NOTE: Disk Scrub Head Kit, Nobles Part Number 391029, includes Fig. 16 and Fig. 18

Ref.	Nobles- Part No.	Description	Qty.	
	1	391370	Head Wldt, Scb, Disk, 28 Inch	1
▽	2	390849	Motor, Ele, 36vdc, 0.50hp, 0320rpm	2
▲		611287000	Brush Assy, Motor	1
	3	24672	Screw, Hex, .25-20 X 0.75, Ss	8
	4	01684	Washer, Flt, 0.25 Ss	8
	5	390933	Hose, Pvc, Brd, 0.50id (376716)	25.00'
	6	1011403	Hose, Afmkt Pvc, Brd 0.50id X 1 Ft (376716)	0.550'
	7	223645	Molding, Trim, Rbr, .13 03.0	1
	8	54333	Clamp, Hose, Wormdrive, 0.31-0.88d	5
	9	63245-1	Fitting, Plstc, Tee, Bm08/Bm08/Bm08	1
	10	01686	Washer, Flat, 0.44b 1.00 .08, Ss	2
	11	44961	Tie, Cable, Nyl, 14.5l .30w 4.0 Max D	1
	12	377364	Hub, Drive, Brush, Disk, 0.75b 6t	2
	13	02991	Screw, Hex, .31-18 X 0.75, Ss	2
	14	41186	Washer, Belleville, .31	2
	15	390633	Skirt, Front, Scb, Disk, 28 Inch	1
	16	390635	Strip, Retainer, Skirt, Front, 28 Inch	1
	17	390634	Skirt, Rear, Scb, Disk, 28 Inch	1
	18	390636	Strip, Retainer, Skirt, Rear, 28 Inch	1
	19	08716	Screw, Hex, M06 X 1.0 X 20, Ss	9
	20	01684	Washer, Flt, .25 Ss	9
	21	08712	Nut, Hex, Lock, M06 X 1.0, NI, Ss	9
	22	02942	Pin, Hair Cotter, 0.62 D .120 Wir	1
	23	222196	Pin, Clevis, 0.50 D X 4.00l	1
	24	390741	Channel Wldt, Lift Tool	1
	25	15648	Bushing, Flng, 0.50b 0.59d 0.38l	4
	26	32486	Washer, Flt, .50 Sae	2
	27	00926	Key, Sq, 0.25 X 0.25, 0.75l	2
	28	1011403	Hose, Afmkt Pvc, Brd 0.50id X 1 Ft (376716)	0.550'
	29	1006123	Bracket, Link, Head, Disk	2
	30	01686	Washer, Flat, 0.44b 1.00 .08, Ss	6
	31	10959	Screw, Hex, M10 X 1.5 X 20, SS, NL	4
	32	392882	Link, Balljoint, M10 X 1.5, 11.0L	2
	33	08714	Nut, Hex, Lock, M10 X 1.5, NL, SS	2

▽ ASSEMBLY

▲ INCLUDED IN ASSEMBLY

**Fig. 17 - Disk Scrub Head Squeegee Group, 700 mm (28 in)
(0000000-10214060)**

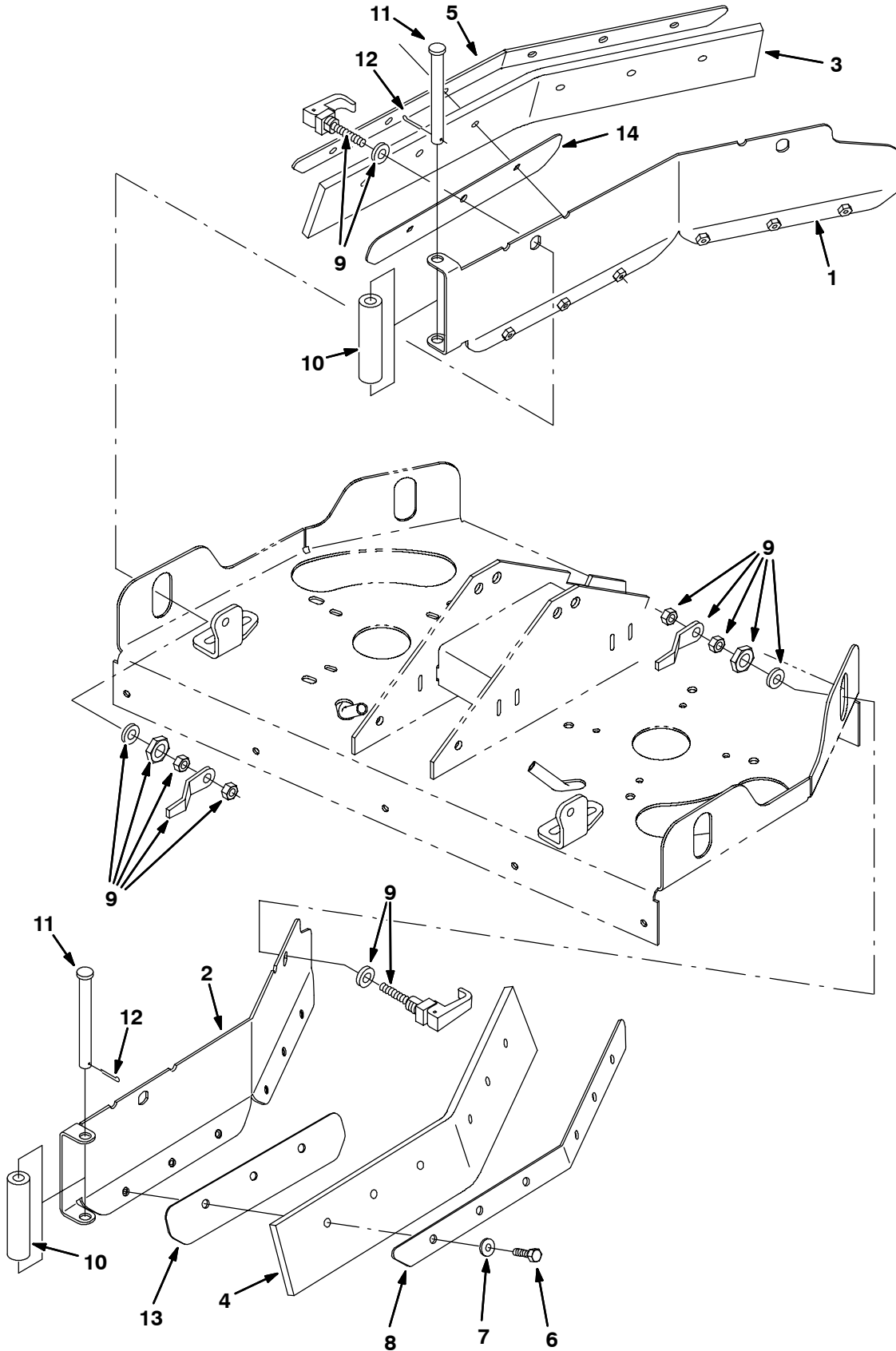

**Fig. 17 - Disk Scrub Head Squeegee Group, 700 mm (28 in)
(00000000-10214060)**

NOTE: Disk Scrub Head Kit, Nobles Part Number 393001, includes Fig. 15 and Fig. 17.

Ref.	Nobles- Part No.	Description	Qty.
1	1001268	Angle, Rh	1
2	392841	Angle, Lh	1
3	1001290	Blade, Sqge, Rh	1
4	392842	Blade, Sqge, Lh	1
5	392823	Retainer, Rh	1
6	392840	Retainer, Lh	1
7	09007	Screw, Hex, M06 X 1.0 X 25, Ss	12
8	01684	Washer, Flat, .25 Ss	12
9	65695	Latch	4
10	222055	Roller, Linkage, Head	2
11	222197	Pin, Clevis, 0.50 D X 4.75l	2
12	08175	Pin, Cotter, .125 X 1.25	2
13	1008969	Plate, Backup, Sqge, Lh	1
14	1008981	Plate, Backup, Sqge, Rh	1

STANDARD PARTS

Fig. 18 - Disk Scrub Head Squeegee Group, 700 mm (28 in)
(10214061-)

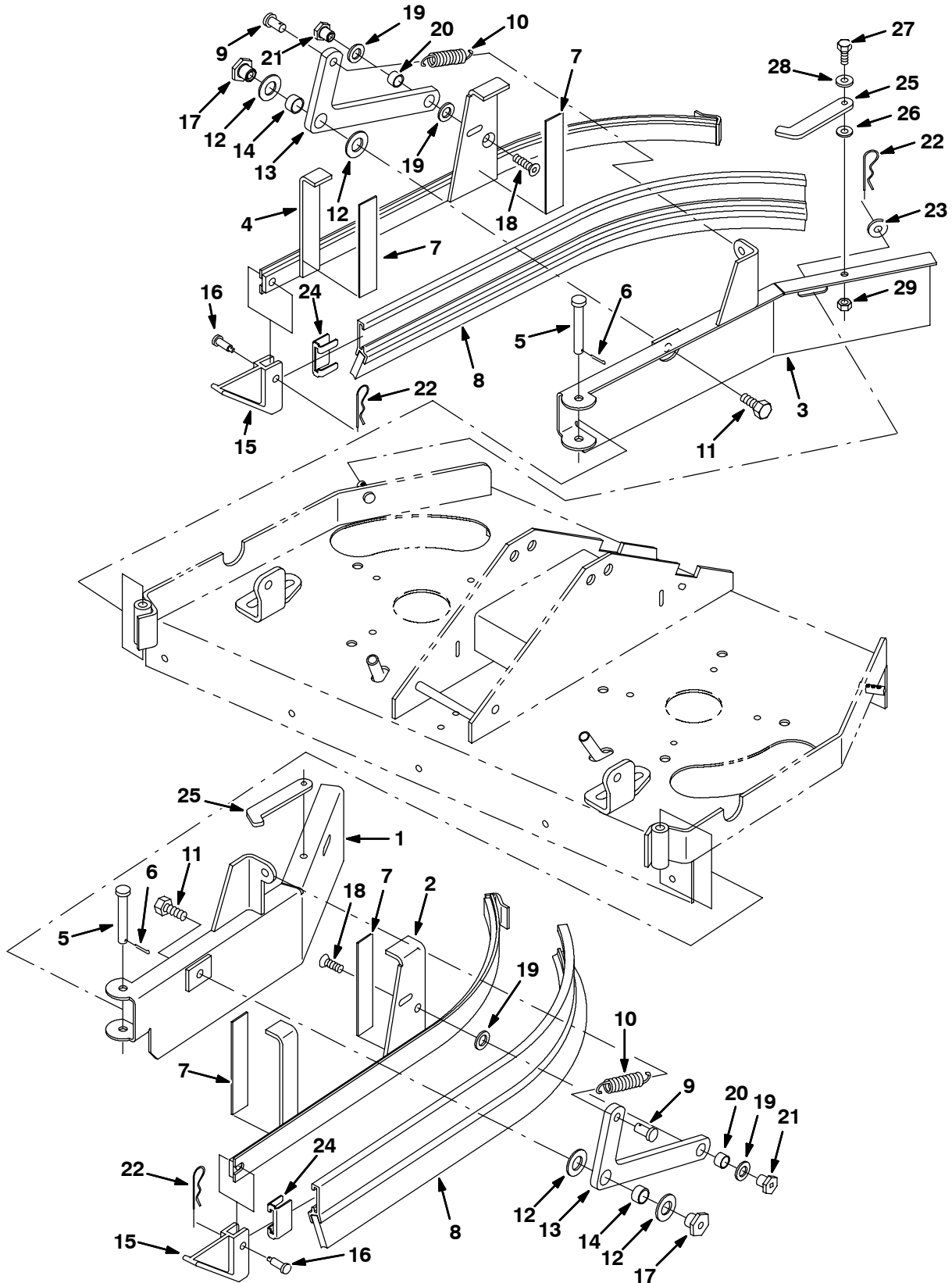

Fig. 18 - Disk Scrub Head Squeegee Group, 700 mm (28 in)
(10214061-)

NOTE: Disk Scrub Head Kit, Nobles Part Number 391029, includes Fig. 16 and Fig. 18.

Ref.	Nobles- Part No.	Description	Qty.
1	390702	Door Wldt, Mtg, Lh, 28 Inch Disk	1
2	390707	Bladeholder Wldt, Sqge, Disk, Lh	1
3	390710	Door Wldt, Mtg, Rh, 28 Inch Disk	1
4	390720	Bladeholder Wldt, Sqge, Disk, Rh	1
5	391179	Pin, Clevis, 0.37 D X 2.62l	2
6	08182	Pin, Cotter, .125 X 1.00	2
7	390988	Tape, [Protective], .0080th, 1.0w, 5.0l	4
8	86859	Squeegee Assy, Side [Linatex]	2
9	39019	Pin, Clevis, 0.37 D X 0.75l	2
10	15047	Spring, Extn, 0.62od X 0.08wir, 3.0l	2
11	09291	Screw, Hex, M10 X 1.5 X 20, Ss	2
12	64425	Washer, Thrust, 0.61b 1.25d .06, Fgl	4
13	25709	Bellcrank, Lift, Sqge	2
14	71607	Bushing, Sleeve, 0.63b 0.72d 0.38l	2
15	86865	Guide, Side Sqge	2
16	69582	Pin, Clevis, 0.31 D X 1.00l	2
17	391345	Nut, T, M 10 X1.5 0.623od .516lg	2
18	79246	Screw, Flat, M08-1.25x 20, Ss	2
19	86860	Bearing, Thrust	4
20	64173	Bushing, Sleeve, 0.50b 0.59d 0.38l, Stl	2
21	391346	Nut, T, M8x1.25 X0.498od, 0.516lg	2
22	44906	Pin, Hair Cotter, 0.69 D .092 Wir	4
23	01686	Washer, Flat, 0.44b 1.00 .08, Ss	2
24	86759	Retainer, Sqge	2
25	390997	Lever, Lock, Side Sqge	2
26	16236	Washer, 0.26b 0.72d .06, Nyl	2
27	08716	Screw, Hex, M06 X 1.0 X 20, Ss	2
28	01684	Washer, Flat, .25 Ss	2
29	08712	Nut, Hex, Lock, M06 X 1.0, NI, Ss	2

Fig. 19 - Recovery Tank Group

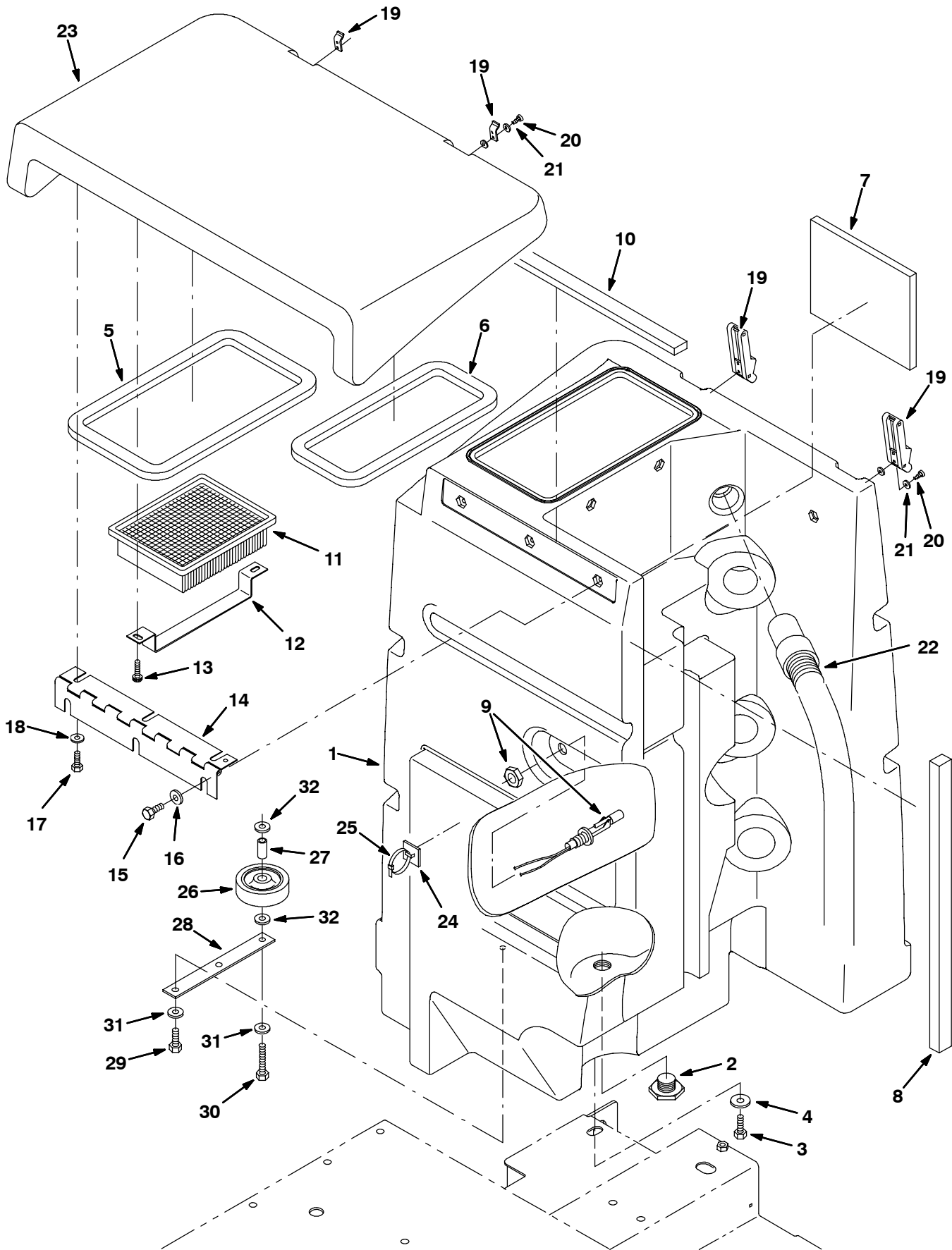

Fig. 19 - Recovery Tank Group

	Ref.	Nobles- Part No.	Description	Qty.
	1	392951	Tank, Recvy, W/ Es, Afmkt [Ezrider Hp]	1
▽		392952	Tank, Recvy, W/O Es, Afmkt [Ezrider Hp]	1
▲	2	75611	Fitting, Plstc, Plug, Pm12	1
	3	12273	Screw, Hex, M08 X 1.25 X 20, Ss, NI	3
	4	13248	Washer, 0.40b 1.12d .12, Stl, PI	3
	5	390882	Seal, Tank, Recvy	1
	6	390883	Seal, Tank, Soltn	1
	7	391338	Insulation, Acstc	1
	8	391341	Insulation, Acstc	1
	9	222822	Sensor, Level, Liquid [Magnetic]	1
	10	391372	Insulation, Acstc	1
	11	386326	Filter, Fan	1
	12	393133	Bracket, Filter	1
	13	603012	Knob, Rnd, . D . L	2
	14	391351	Hinge, .25pin .08 3.5w 13.0l 4/.25slot	1
	15	09740	Screw, Hex, M08 X 1.25 X 20, Ss	3
	16	01685	Washer, Flat, .31 Ss	3
	17	15678	Screw, Hex, M06 X 1.0 X 16, Ss	3
	18	01684	Washer, Flat, .25 Ss	3
	19	49800	Latch	2
	20	391403	Screw, Pan, M04x0.7 X 8, Ss	8
	21	41578	Washer, Flat, #06 Ss	8
	22	390946	Hose, Vacuum	1
	23	391146	Cover, Tank, Trim [Nobles]	1
	24	55248	Mount, Cable Tie	1
	25	49266	Tie, Cable, Nyl 07.3L .19W 1.8 Max D	1
	26	81580	Wheel, 4.0d 0.87w 0.44b	1
	27	393129	Sleeve, P/M, 0.437d 0.318b 1.15l 430ss	1
	28	390822	Strip	1
	29	09740	Screw, Hex, M08 X 1.25 X 20, Ss	2
	30	49694	Screw, Hex, M08 X 1.25 X 50, Ss	1
	31	01685	Washer, Flt, .31 Ss	6
	32	32490	Washer, Flat, .25 Std	2

▽ ASSEMBLY

▲ INCLUDED IN ASSEMBLY

Fig. 20 - Vacuum Fan Group

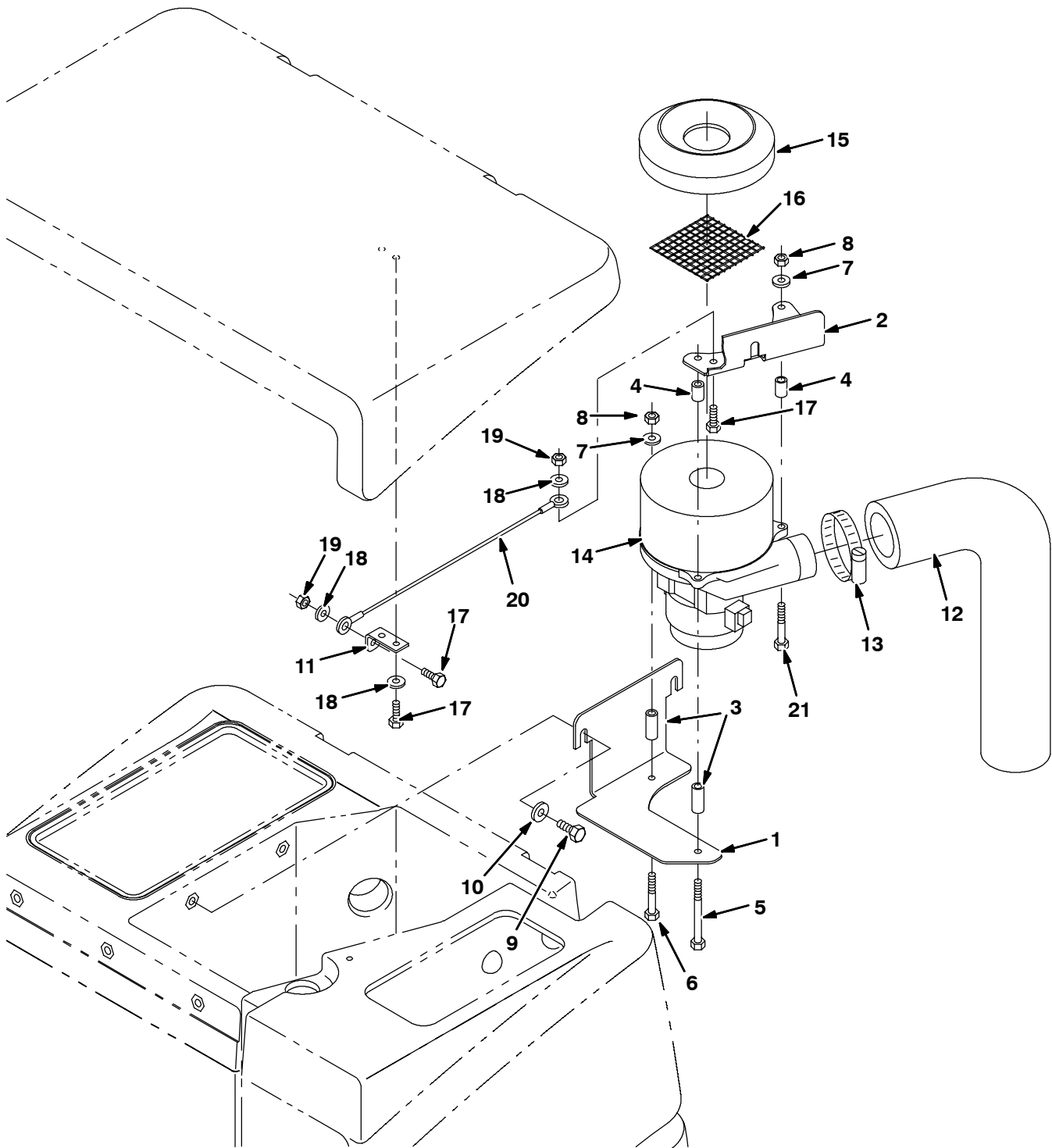

Fig. 20 - Vacuum Fan Group

Ref.	Nobles- Part No.	Description	Qty.	
1	393027	Bracket, Fan	1	
2	393028	Bracket, Fan	1	
3	222497	Sleeve	2	
4	360930	Sleeve	2	
5	391434	Screw, Hex, M06 X 1.0 X 80, Ss	1	
6	58979	Screw, Hex, M06 X 1.0 X 55, Ss	1	
7	01684	Washer, Flt, .25 Ss	3	
8	08712	Nut, Hex, Lock, M06 X 1.0, NI, Ss	3	
9	09740	Screw, Hex, M08 X 1.25 X 20, Ss	3	
10	01685	Washer, Flt, .31 Ss	3	
11	391309	Bracket, Cable	1	
12	390677	Muffler, Vacuum Fan	1	
13	22297	Clamp, Hose, Wormdrive, 1.56-2.50d	1	
▽	14	391296	Fan Assy, Vacuum (See Breakdowns)	1
▲	15	391343	Seal, Fan	1
▲	16	391350	Screen, Fan Inlet	1
	17	08716	Screw, Hex, M06 X 1.0 X 20, Ss	4
	18	01684	Washer, Flt, .25 Ss	4
	19	08712	Nut, Hex, Lock, M06 X 1.0, NI, Ss	2
	20	391368	Cable	1
	21	33930	Screw, Hex, M06 X 1.0 X 40, Ss	1

▽ ASSEMBLY

▲ INCLUDED IN ASSEMBLY

Fig. 21 - Solution Tank Group

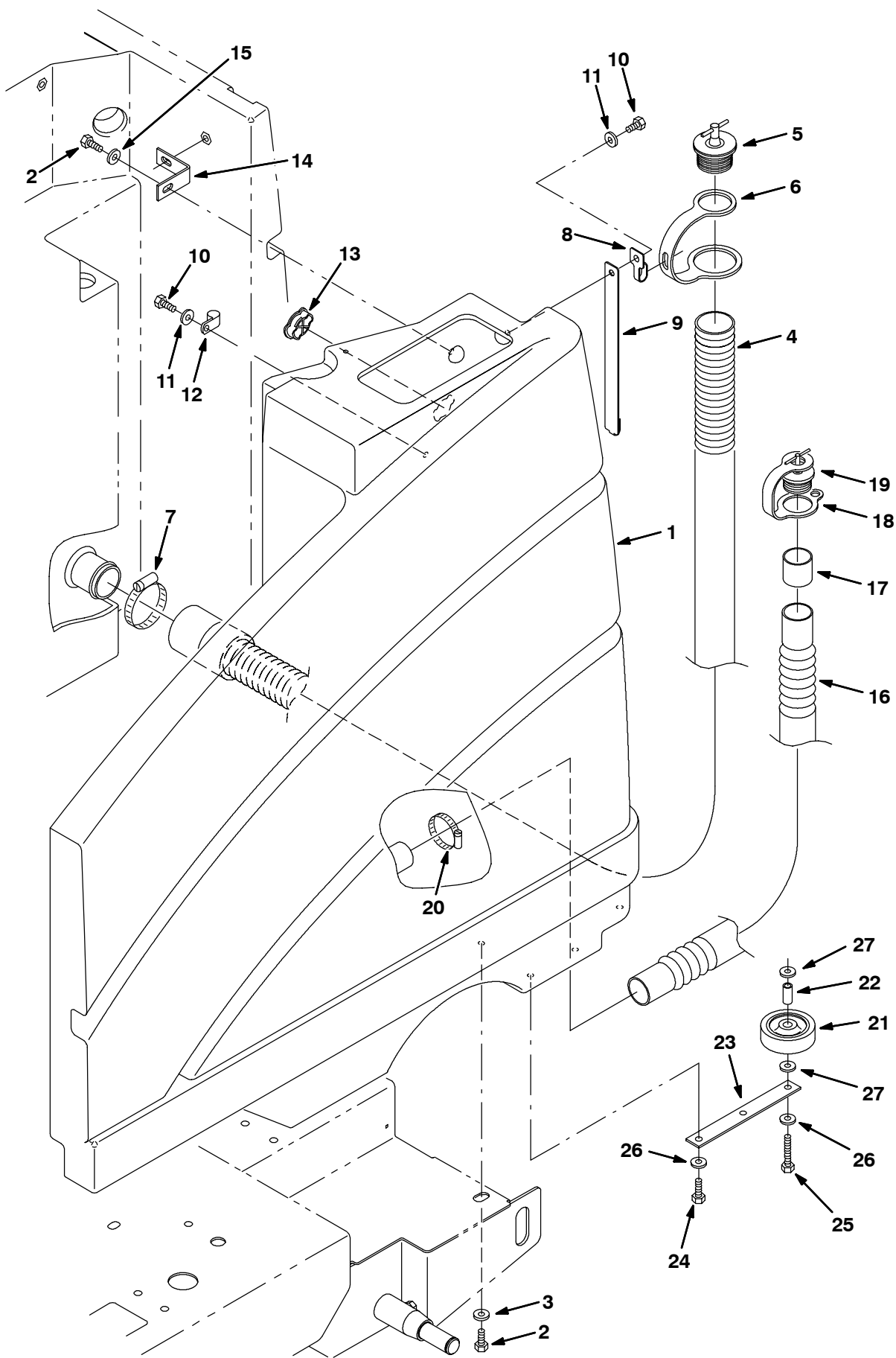

Fig. 21 - Solution Tank Group

Ref.	Nobles- Part No.	Description	Qty.
1	392901	Tank, Soltn, Trim [Ezrider Hp]	1
2	12273	Screw, Hex, M08 X 1.25 X 20, Ss, NI	5
3	13248	Washer, 0.40b 1.12d .12, Stl, PI	3
4	391317	Hose, Drain	1
5	391318	Plug, Expansion, 2.00 Dia	1
6	391319	Strap, Hose, Drain	1
7	17188	Clamp, Hose, Wormdrive, 1.62-3.50d	1
8	222793	Clip, Hanger, Hose	1
9	392878	Clip, Hose, Hanger	1
10	09740	Screw, Hex, M08 X 1.25 X 20, Ss	2
11	01685	Washer, Flat, .31 Ss	2
12	67767	Clamp, Cable, Stl, 0.69d X 0.62w, 1h	1
13	390994	Plug, Tank, Solution	1
14	392963	Angle, Bracket, Tank	1
15	01685	Washer, Flat, .31 Ss	2
16	630068	Hose, Drain, 1.50id X 32.0l Scrubber	1
17	630394	Sleeve, Hose, Drain, 1.5id Copp	1
18	578441	Strap Drain Hose 170/443/E17	1
19	621324	Plug Expansion 1-1/2"Dia	1
20	140308	Clamp, Hose 1-5/16 To 2-1/4 Ss	1
21	81580	Wheel, 4.0d 0.87w 0.44b	1
22	393129	Sleeve, P/M, 0.437d 0.318b 1.15l 430ss	1
23	390822	Strip	1
24	09740	Screw, Hex, M08 X 1.25 X 20, Ss	3
25	49694	Screw, Hex, M08 X 1.25 X 50, Ss	1
26	01685	Washer, Flt, .31 Ss	8
27	32490	Washer, Flat, .25 Std	2

Fig. 22 - Solution Control Group

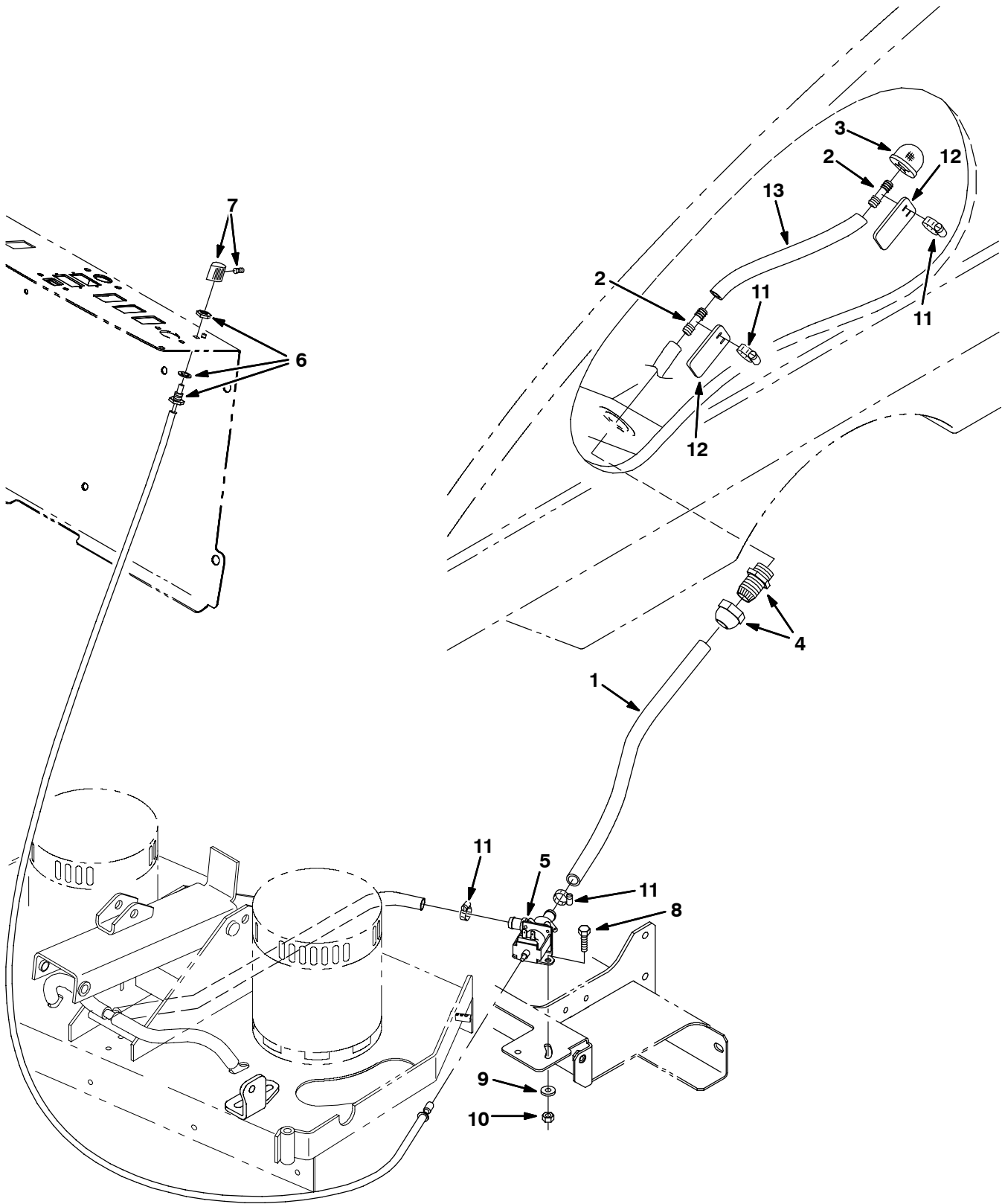

Fig. 22 - Solution Control Group

Ref.	Nobles- Part No.	Description	Qty.
1	392874	Hose, Pvc, Brd, 0.50id, 0.73od, 21.0l (376716)	21.00'
2	364631	Fitting, Plstc, Str, Bm08/Bm08	2
3	222742	Screen, Drain	1
4	222374	Fitting, Plstc, Str, Spcl, 12pm/10cf	1
5	626100	Valve, Solution	1
	614265	Kit, Water, Valve, Rebuild	1
6	392955	Cable, Water Flow, [Ezrider Hp]	1
7	626121	Knob, Rnd, 0.71d 0.75l 0.25b Plstc	1
8	08716	Screw, Hex, M06 X 1.0 X 20, Ss	2
9	01684	Washer, Flat, .25 Ss	2
10	08712	Nut, Hex, Lock, M06 X 1.0, NI, Ss	2
11	54333	Clamp, Hose, Wormdrive, 0.31-0.88d	4
12	1005770	Weight, Soltn Hose	2
13	393150	Hose, Pvc, Brd, 0.50ld, 0.73Od, 15.0L (376716)	15.00'

Fig. 23 - Battery Cable Group

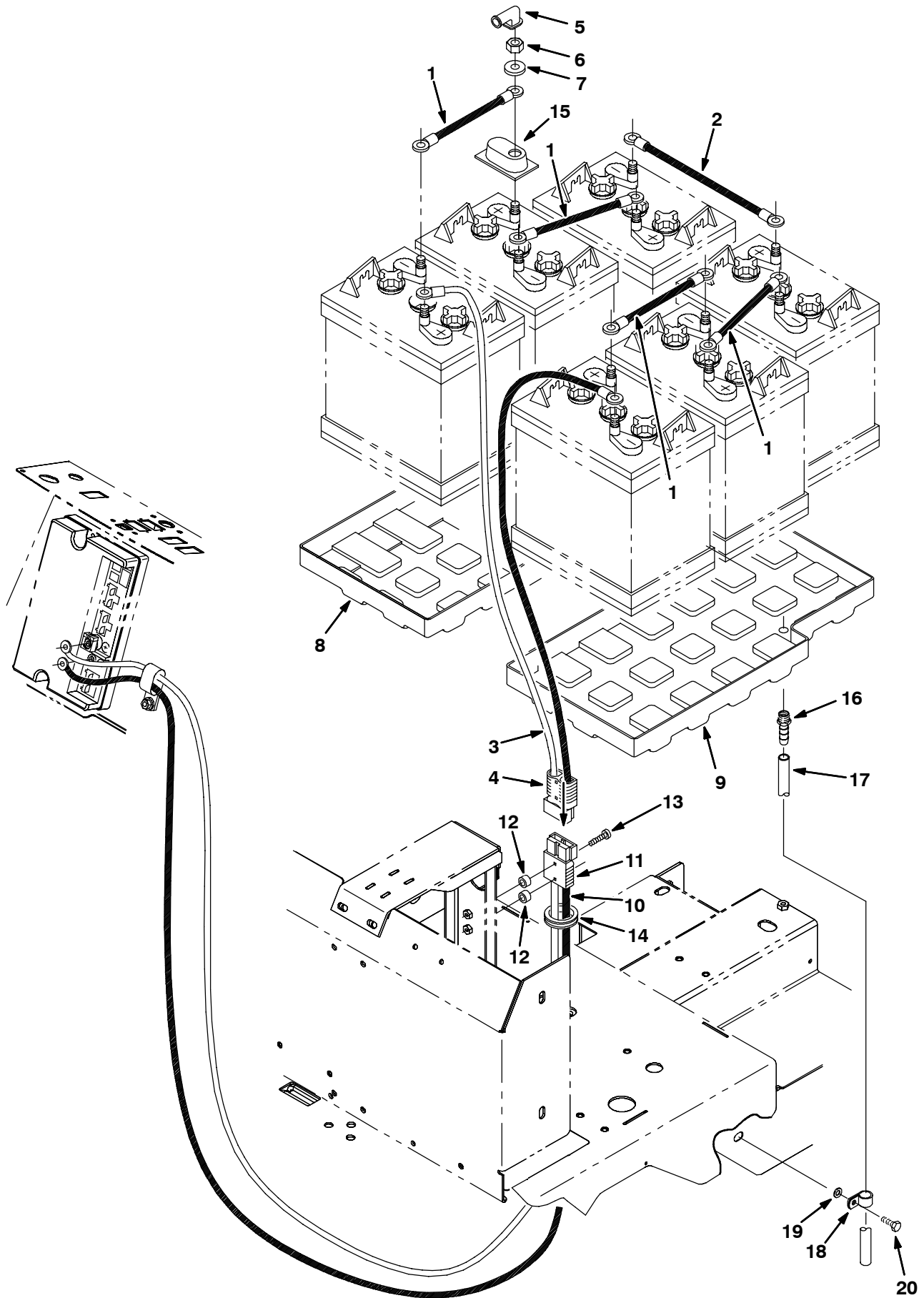

Fig. 23 - Battery Cable Group

Ref.	Nobles- Part No.	Description	Qty.	
	1	223355	Wire, 04ga 08.0l Blk .34ring /.34ring	4
	2	223356	Wire, 04ga 12.0l Blk .34ring /.34ring	1
▽	3	223361	Cable Assy, Battery, 04ga 2, 175a	1
▲	4	22892	Connector, Anderson, 175a, Gray	1
	5	02076	Boot, 90deg .50d .57d X .84	12
	6	87435	Nut, Hex, Flexlock, .31-18	12
	7	01685	Washer, Flt, .31 Ss	12
	8	393117	Tray, Battery, Rh	1
	9	393118	Tray, Battery, Lh	1
▽	10	393125	Cable, Battery	1
▲	11	22892	Connector, Anderson, 175a, Gray	1
	12	390879	Spacer, .41b X .63od X .38l	2
	13	09258	Screw, Pan, M06 X 1.0 X 40, 4.8	2
	14	04051	Grommet, Rbr, 1.31id, F/ 1.6h, .12matl	1
	15	45962	Cap, Plstc, .04 1.38 X 2.30 0.5l	12
▽		377393	1 Drain Kit	1
▲	16	150516	Fitting, Brs, Str, BM06/PM04	1
▲	17	1014929	Hose, Afrmkt, Pvc, Clr, 0.38ld 1Ft (C080172)	1
▲	18	67767	Clamp, Cable, Stl, 0.69d X 0.62w, 1h	1
	19	01685	Washer, Flt, .31 Ss	1
	20	09010	Screw, Hex, M08 X 1.25 X 25, Ss	1

1 Serial number (00000000-10180867)

▽ ASSEMBLY

▲ INCLUDED IN ASSEMBLY

Fig. 24 - Rear Squeegee Lift Group

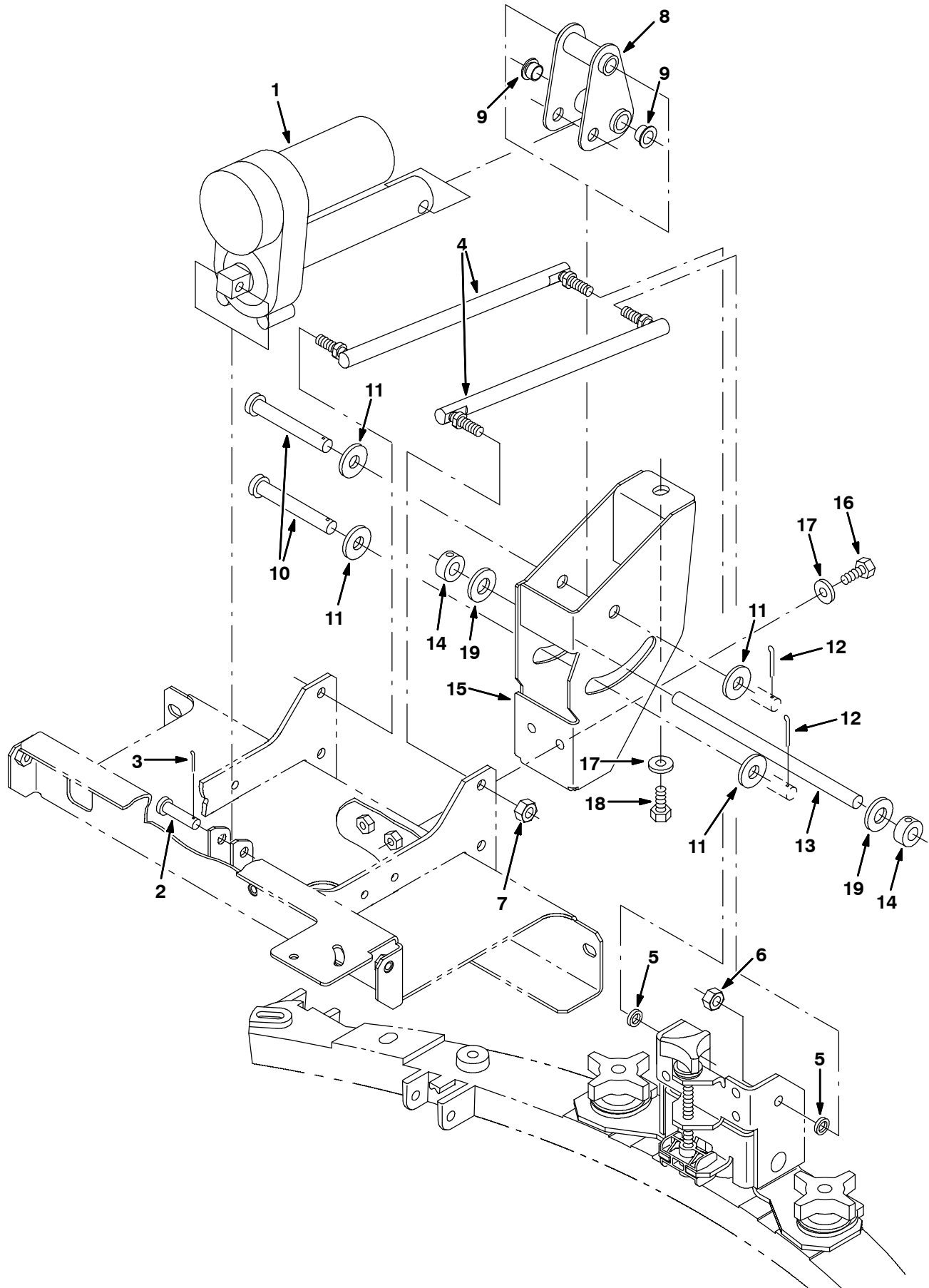

Fig. 24 - Rear Squeegee Lift Group

Ref.	Nobles- Part No.	Description	Qty.
1	390989	Actuator, 36vdc, 02.0stroke 300lb	1
2	29558	Pin, Clevis, 0.37 D X 1.50l	1
3	39005	Pin, Cotter, .094 X 0.75	1
4	392881	Link, Balljoint, .38-24, 10.5l	2
5	390880	Spacer, .41b .63d .13l, Ss 430pm	2
6	02185	Nut, Hex, Lock, .38-24, NI, Thin	2
7	50269	Nut, Hex, Lock, .38-24, NI, Ss	2
8	390965	Pivot Wldt, Actuator	1
9	15648	Bushing, Flng, 0.50b 0.59d 0.38l	2
10	06474A	Pin, Clevis, 0.50 D X 3.50l	2
11	41619	Washer, Flt, .50 Ss	4
12	08182	Pin, Cotter, .125 X 1.00	2
13	390970	Rod, Lift, Sqge	1
14	75371	Collar, Locking	2
15	1008388	Guide Wldt, Linkage, Sqge	1
16	12273	Screw, Hex, M08 X 1.25 X 20, Ss, NI	2
17	01685	Washer, Flt, .31 Ss	3
18	09740	Screw, Hex, M08 X 1.25 X 20, Ss	1
19	608562	Washer, Flat, 0.51b 0.94d .06, Nyl	2

Fig. 25 - Rear Squeegee Linkage Group

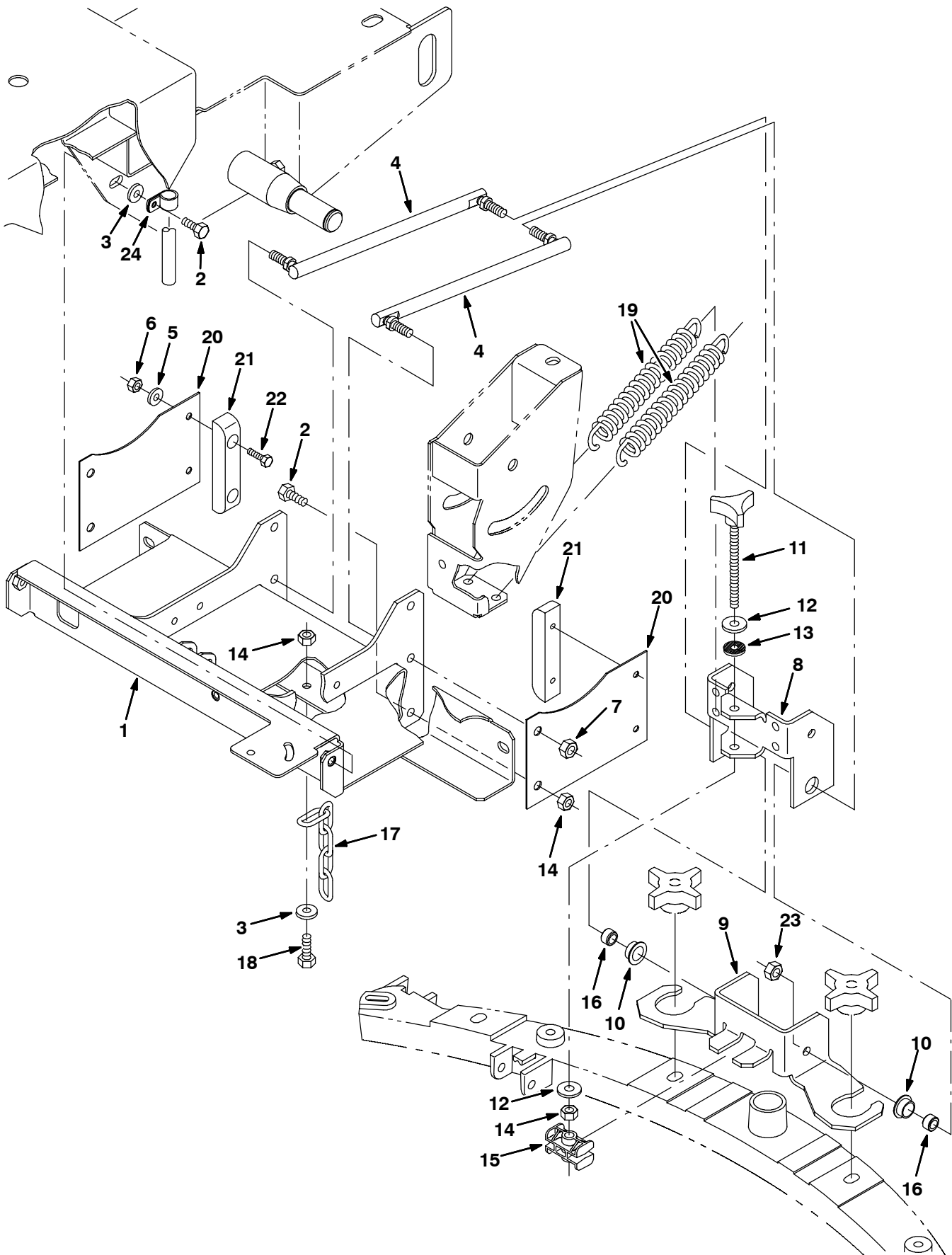

Fig. 25 - Rear Squeegee Linkage Group

Ref.	Nobles- Part No.	Description	Qty.
1	1016045	Frame Wldt, Linkage, Sqge	1
2	09740	Screw, Hex, M08 X 1.25 X 20, Ss	6
3	01685	Washer, Flt, .31 Ss	3
4	392881	Link, Balljoint, .38-24, 10.5l	2
5	01684	Washer, Flt, .25 Ss	4
6	08712	Nut, Hex, Lock, M06 X 1.0, NI, Ss	4
7	50269	Nut, Hex, Lock, .38-24, NI, Ss	2
8	392902	Channel, Sqge, Upper	1
9	392934	Channel, Sqge, Lower	1
10	25735	Bushing, Flng, 0.63b 0.75d 0.38l	2
11	71090	Knob	1
12	01686	Washer, Flat, 0.44b 1.00 .08, Ss	2
13	63416	Washer, 0.31b 0.88d .12, Rbr	1
14	08713	Nut, Hex, Lock, M08 X 1.25, NI, Ss	4
15	222233	Block, Sqge, Adj	1
16	390879	Spacer, .41b X .63od X .38l	2
17	40758	Chain, Coil, Str, #210, .06.9l 05 Link	1
18	09010	Screw, Hex, M08 X 1.25 X 25, Ss	1
19	222236	Spring, Extn, 1.00od X 0.12wir, 5.0l	2
20	390975	Spring, Centering	2
21	71211	Block, Centering	2
22	09007	Screw, Hex, M06 X 1.0 X 25, Ss	4
23	02185	Nut, Hex, Lock, .38-24, NI, Thin	2
24	67767	Clamp, Cable, Stl, 0.69d X 0.62w, 1h	1

Fig. 26 - Rear Squeegee Group, 700 mm (28 in)

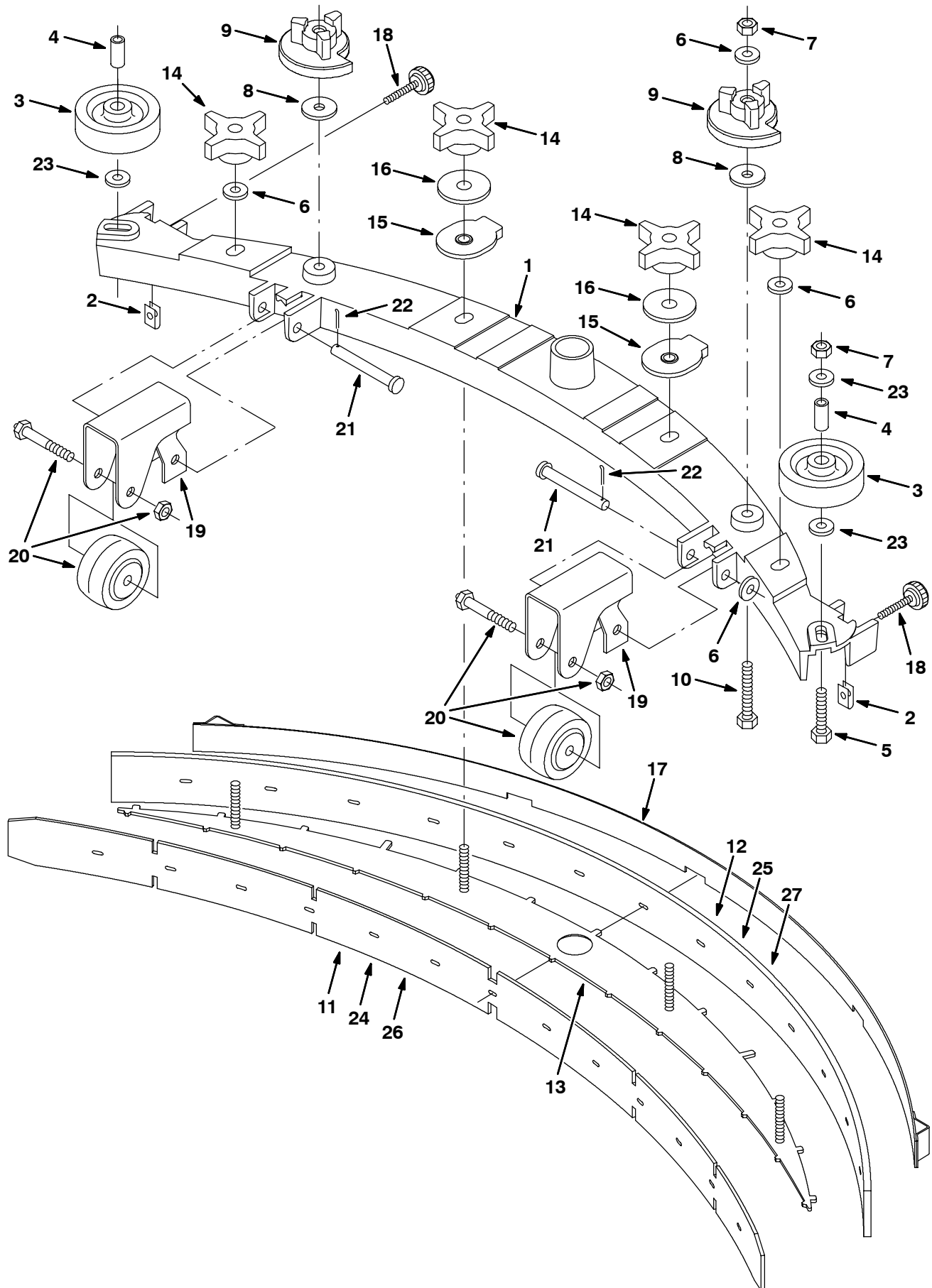

Fig. 26 - Rear Squeegee Group, 700 mm (28 in)

Ref.	Nobles- Part No.	Description	Qty.
▽	392980	Kit, Ci, Sqge Assy, Rear, 700mm[Ez/7080]	1
▲	1 390670	Frame, Casting, Sqge, 700mm	1
▲	2 82138	Nut, Speed, Retainer, .25-20	2
▲	3 1010560	Wheel, Bmpr, 80d X 25w, Non-marking	2
▲	4 222460	Sleeve, P/M, 0.496d 0.318b 0.50l 430ss	2
▲	5 09011	Screw, Hex, M08 X 1.25 X 30, Ss	2
▲	6 01685	Washer, Flt, .31 Ss	6
▲	7 08713	Nut, Hex, Lock, M08 X 1.25, NI, Ss	4
▲	8 222268	Washer, 0.38b 1.25d .12, Neo	2
▲	9 222244	Cam, Adj, Sqge	2
▲	10 09767	Screw, Hex, M08 X 1.25 X 70, Ss	2
▲▽	391386	Kit, Sqge, Tile, 700mm	1
▲▲	11 390943	Blade, Sqge, Front, 700mm, Linatex, Red	1
▲▲	12 390936	Blade, Sqge, Rear, Gum Rbr, 700mm	1
▲	13 390940	Plate, Retainer, Blade, 700mm	1
▲	14 370100	Knob, 4-Prong W/.31-18, Insert	4
▲	15 390982	Ring, Mtg, Sqge	2
▲	16 04414	Washer, 0.53b 1.88d .12, Stl, PI	2
▲	17 390944	Retainer Wldt, Sqge, 700mm	1
▲	18 222794	Knob	2
▲	19 1005469	Bracket, Wheel, Sqge, Rear	2
▲	20 390773	Wheel Assy, Sqge	2
▲	21 23191	Pin, Clevis, 0.37 D X 3.00l	2
▲	22 39005	Pin, Cotter, .094 X 0.75	2
▲	23 140027	Washer, Flat, 0.35b 0.75d .04 Ss	4
▽	391384	Kit, Sqge, Oil-Rstn, 700mm	1
▲	24 391377	Blade, Sqge, Front, Oil-Rstn, 700mm	1
▲	25 391378	Blade, Sqge, Rear, Oil-Rstn, 700mm	1
▽	392988	Kit, Ci, Sqge, Linatex, 700mm[Ez/7080]	1
▲	26 390943	Blade, Sqge, Front, 700mm	1
▲	27 390942	Blade, Sqge, Rear, 700mm	1

▽ ASSEMBLY

▲ INCLUDED IN ASSEMBLY

Fig. 28 - Electrical Schematic (10143033-10247589)

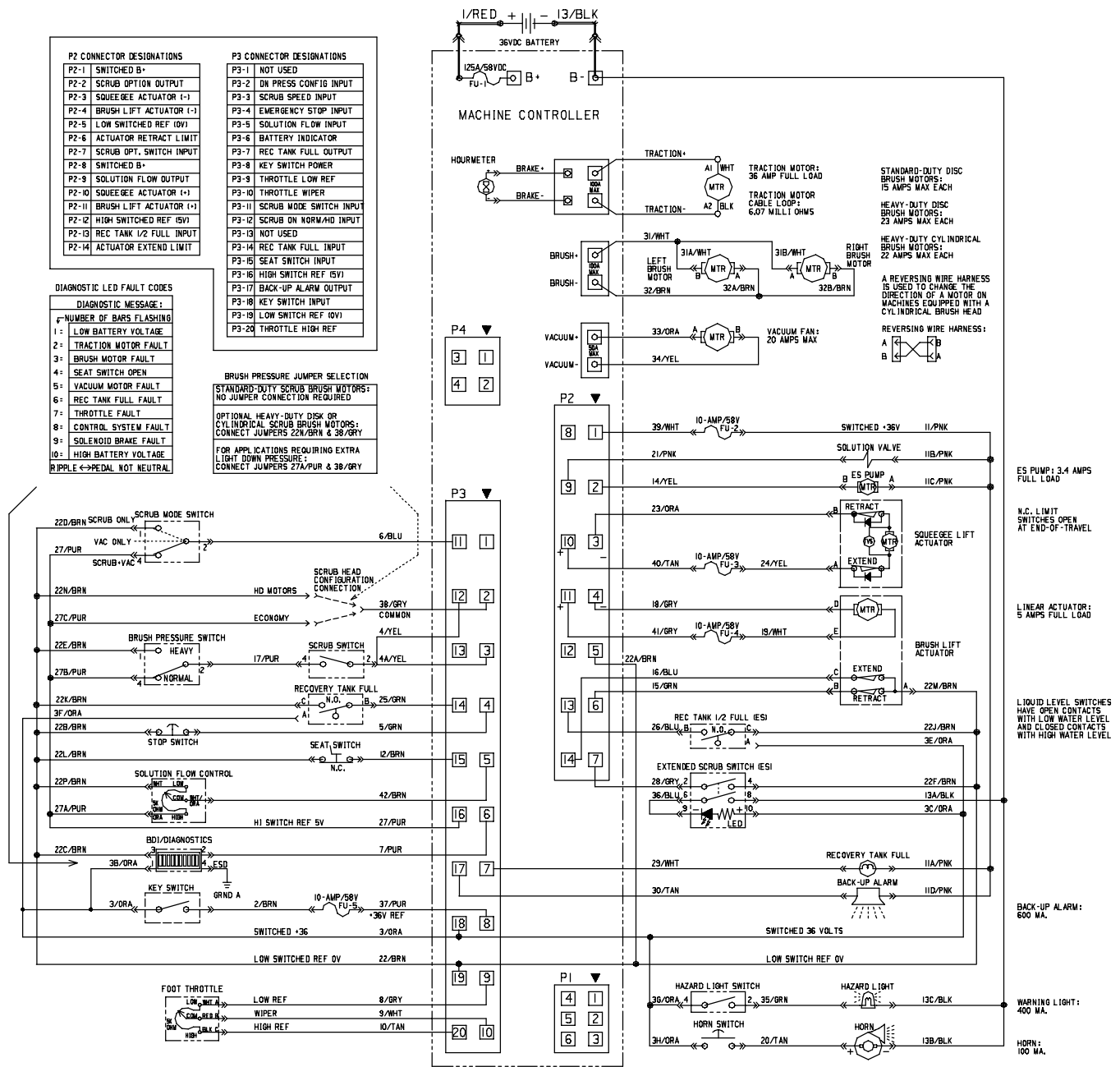

392890, 353803 - EZ, 7080

Fig. 29 - Electrical Schematic (10247590-)

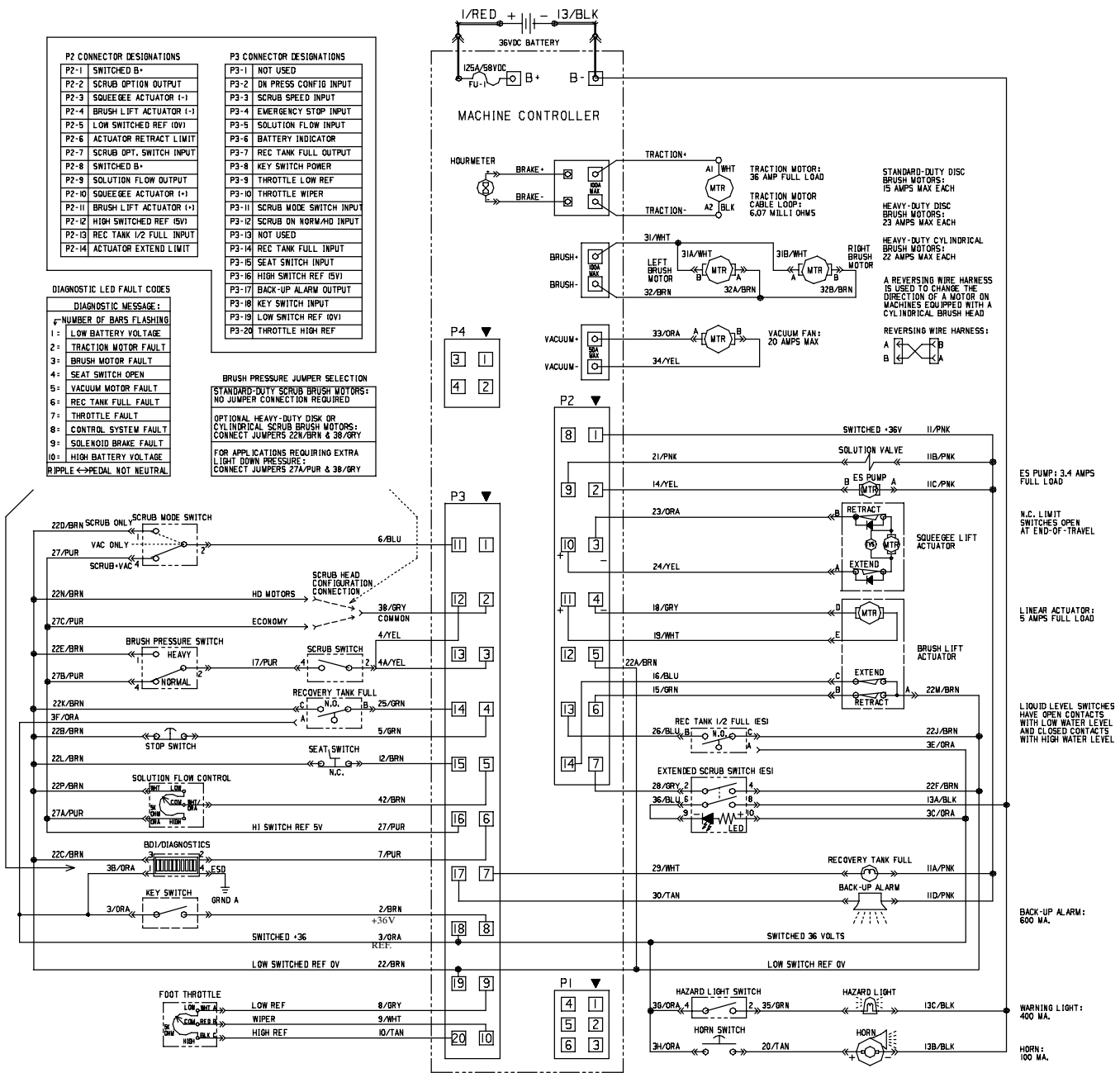

392890, 353803 - EZ, 7080

STANDARD PARTS

Fig. 30 - Wire Harness Group (0000000-10143032)

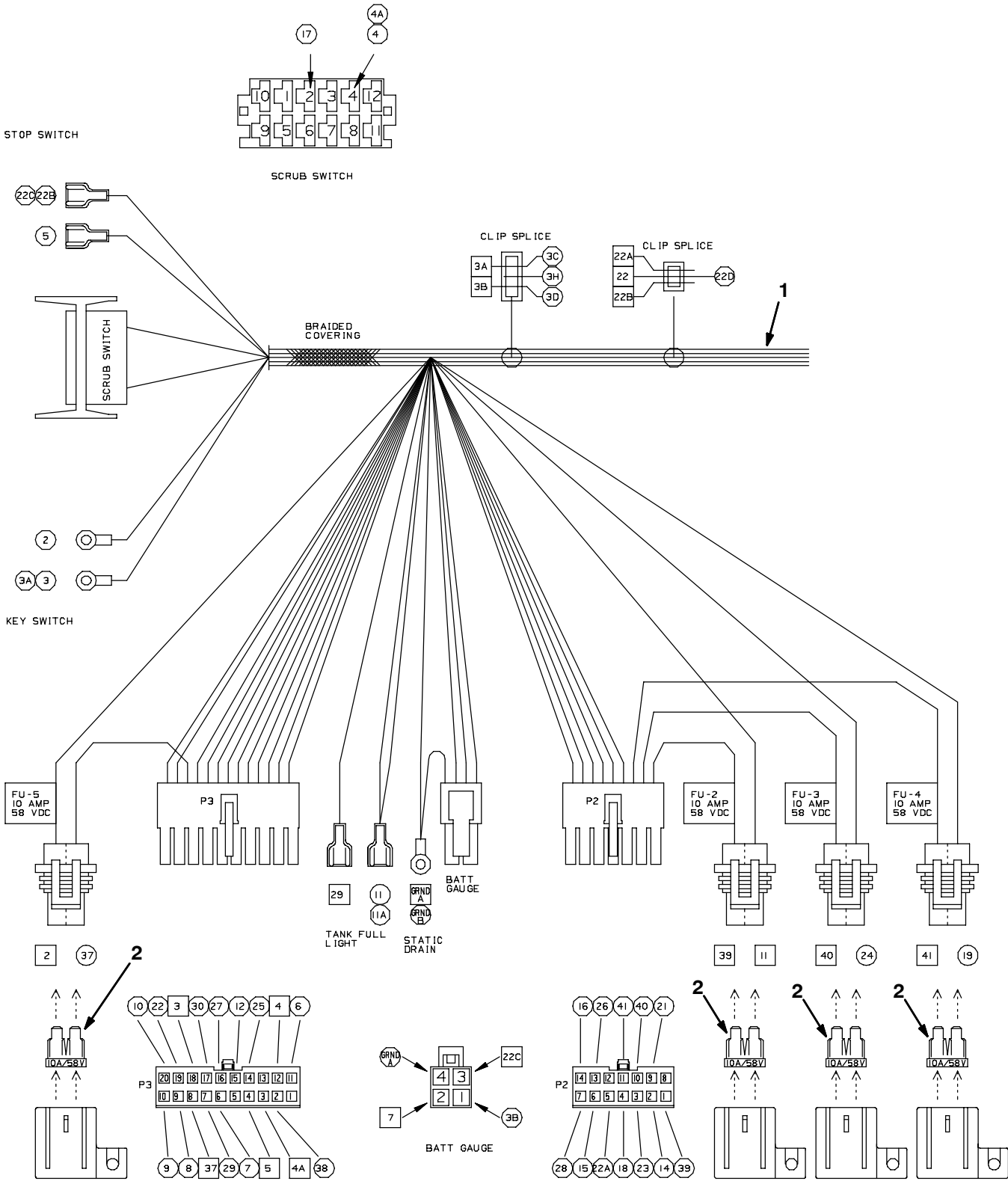
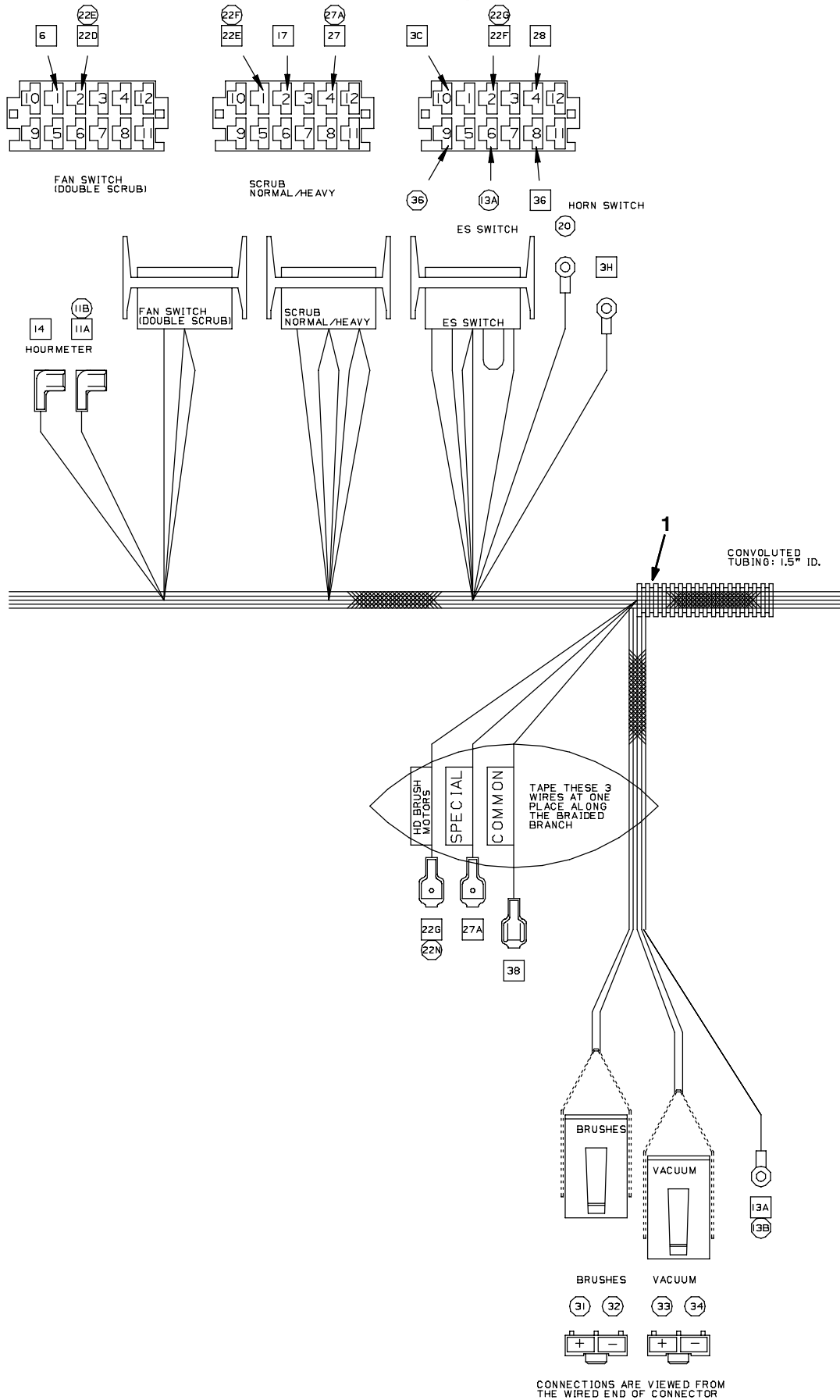

Fig. 30 - Wire Harnesses Group (0000000-10143032)



CONNECTIONS ARE VIEWED FROM THE WIRED END OF CONNECTOR

STANDARD PARTS

Fig. 30 - Wire Harness Group (0000000-10143032)

RECOVERY TANK
1/2 FULL
3E 26 22J

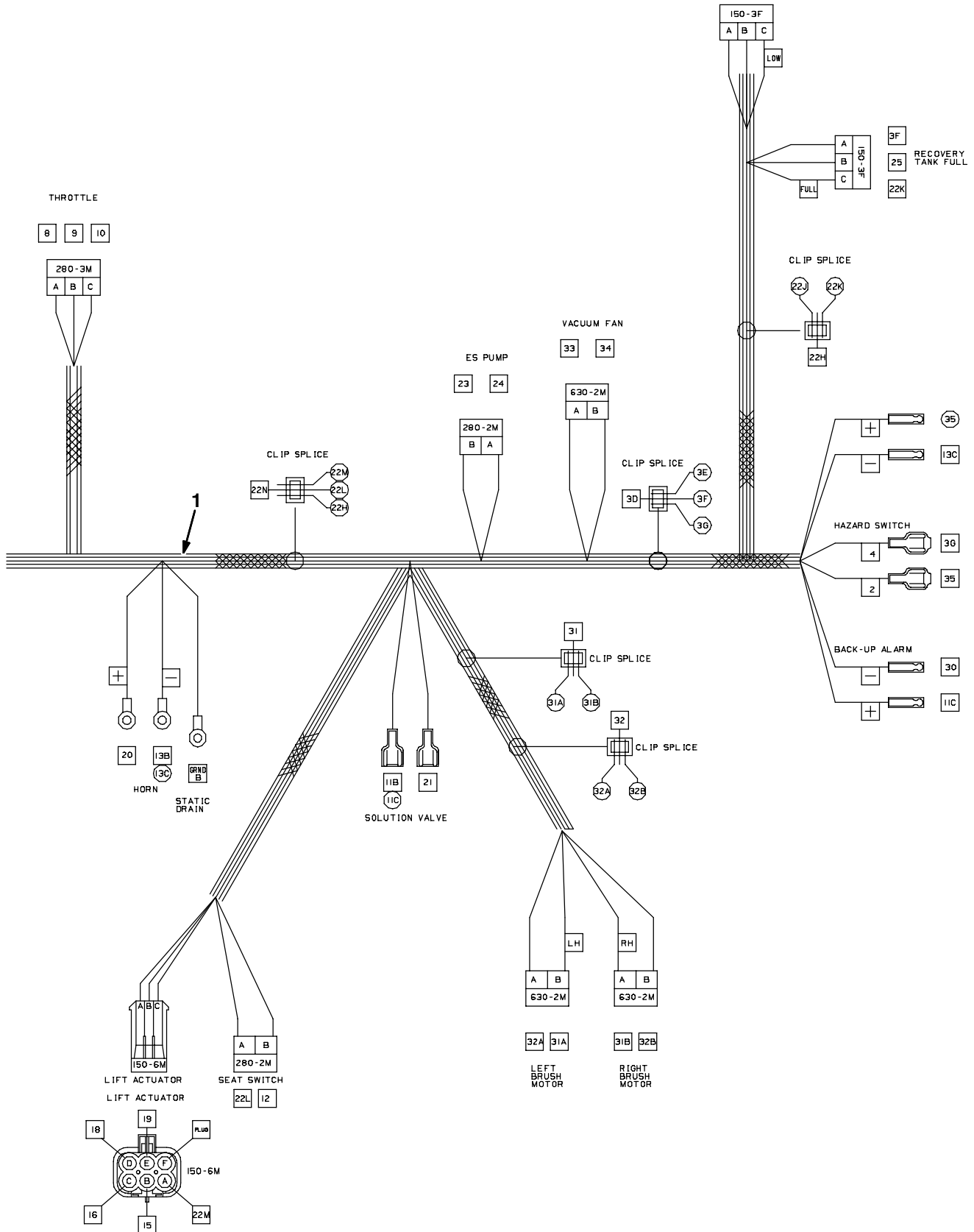

353804

Fig. 30 - Wire Harnesses Group (0000000-10143032)

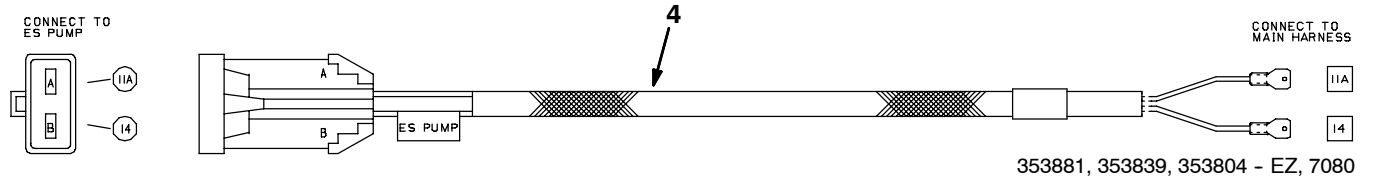
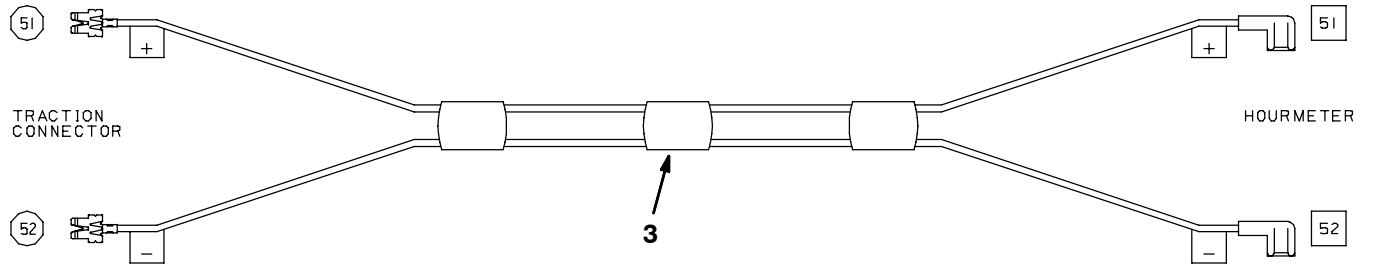

Ref.	Nobles- Part No.	Description	Qty.
1	392891	[1] Harness, Wire [Ez Rider Hp]	1
2	393149	[1] Fuse, Blade, 10a, 58vdc	4
3	393160	[1] Harness, Wire, Hourmeter, Jumper	1
4	393159	[1] Harness, Wire, Es Pump	1

[1] Serial number (0000000-10143032)

STANDARD PARTS

Fig. 31 - Wire Harness Group (10143033-10247589)

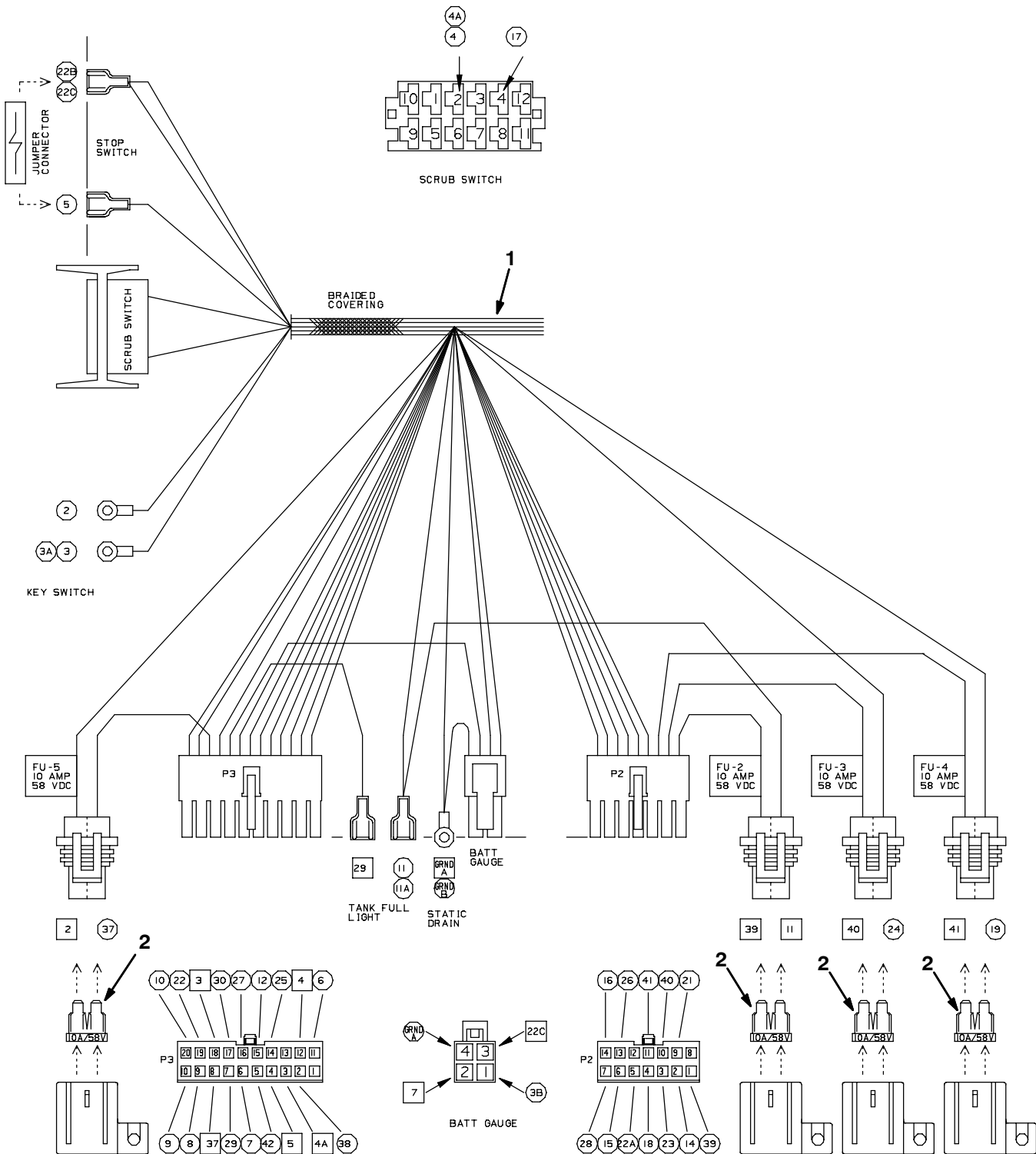

Fig. 31 - Wire Harnesses Group (10143033-10247589)

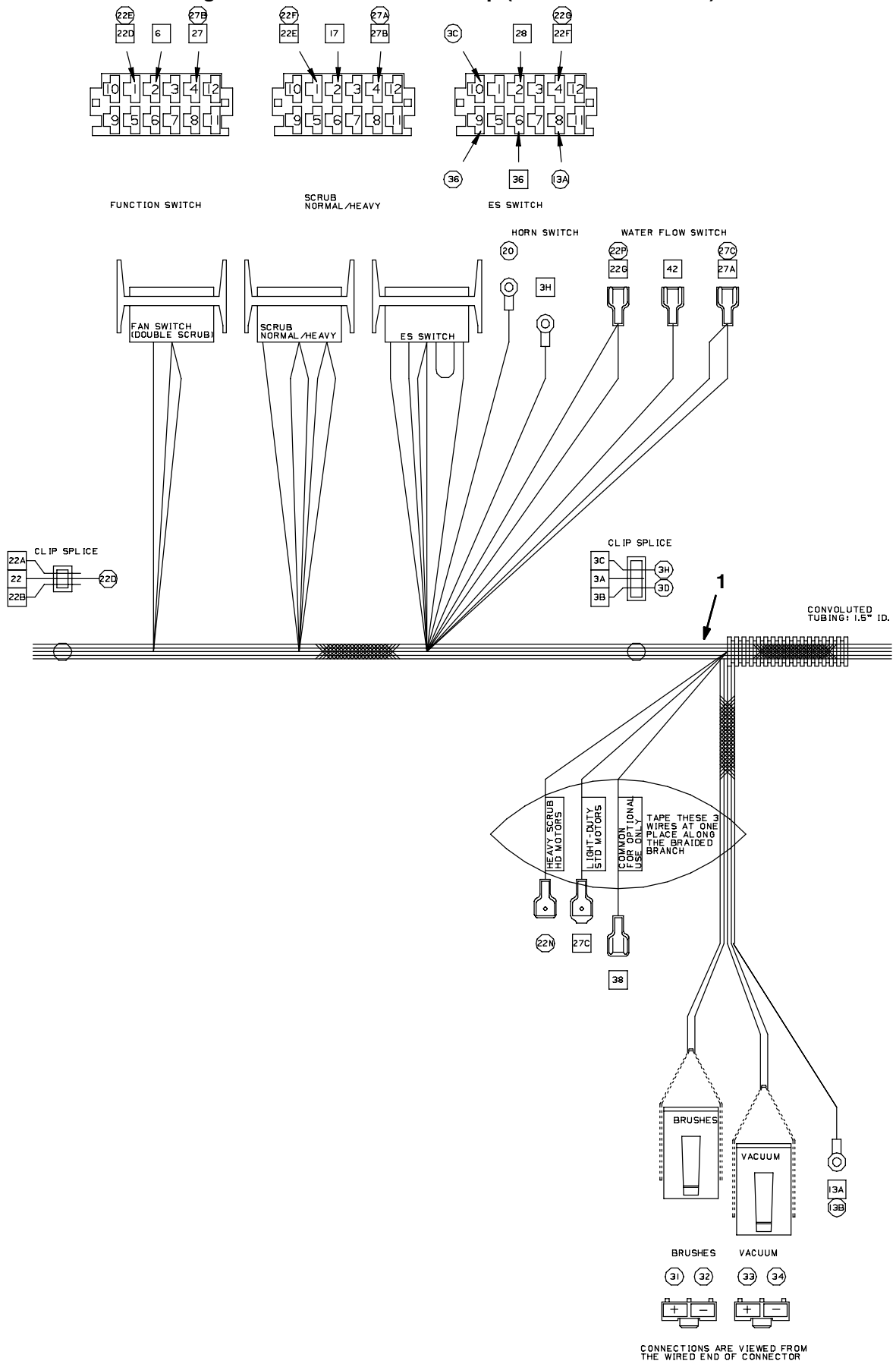
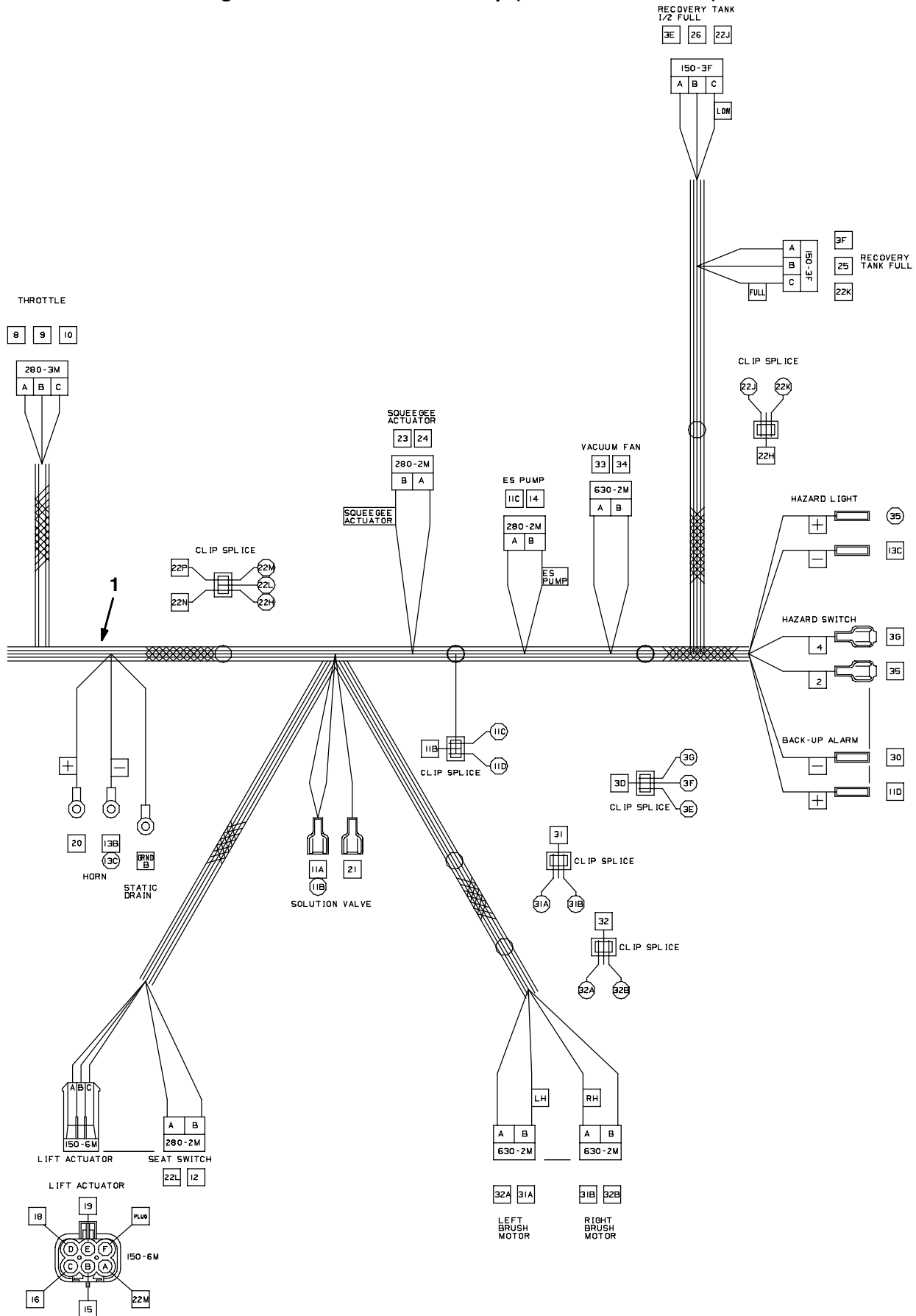
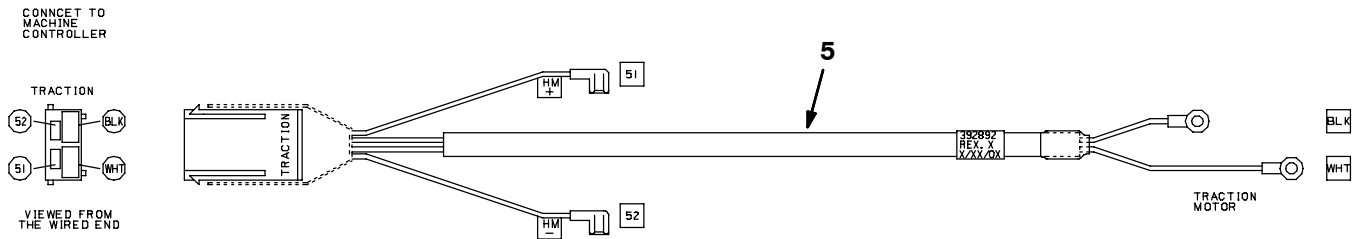
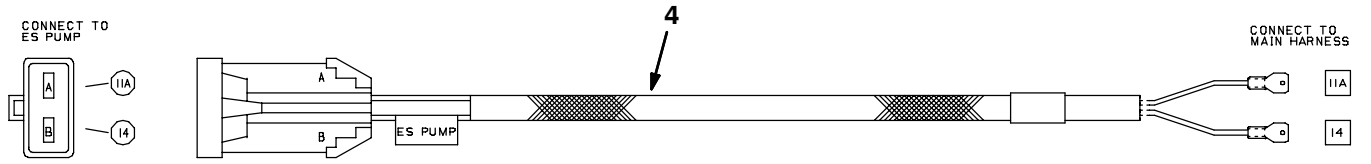
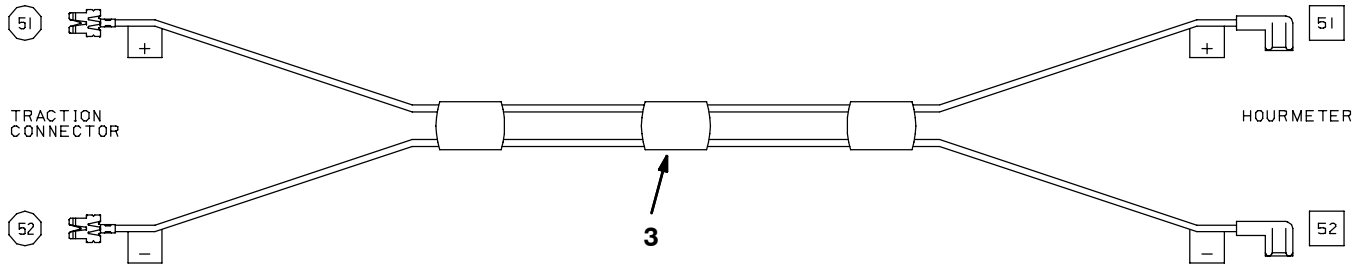

Fig. 31 - Wire Harness Group (10143033-10247589)



353804

Fig. 31 - Wire Harnesses Group (10143033-10247589)



354197, 353881, 353839, 353804 - EZ, 7080

Ref.	Nobles-Part No.	Description	Qty.
1	393162	[2] Harness, Main, [Ezrider Hp]	1
2	393149	[2] Fuse, Blade, 10a, 58vdc	4
3	393160	[2] Harness, Wire, Hourmeter, Jumper	1
4	393159	[2] Harness, Wire, Es Pump	1
5	393161	[2] Harness, Traction, [Ezrider Hp]	1

[2] Serial number (10143033-10247589)

Fig. 32 - Wire Harness Group (10247590-)

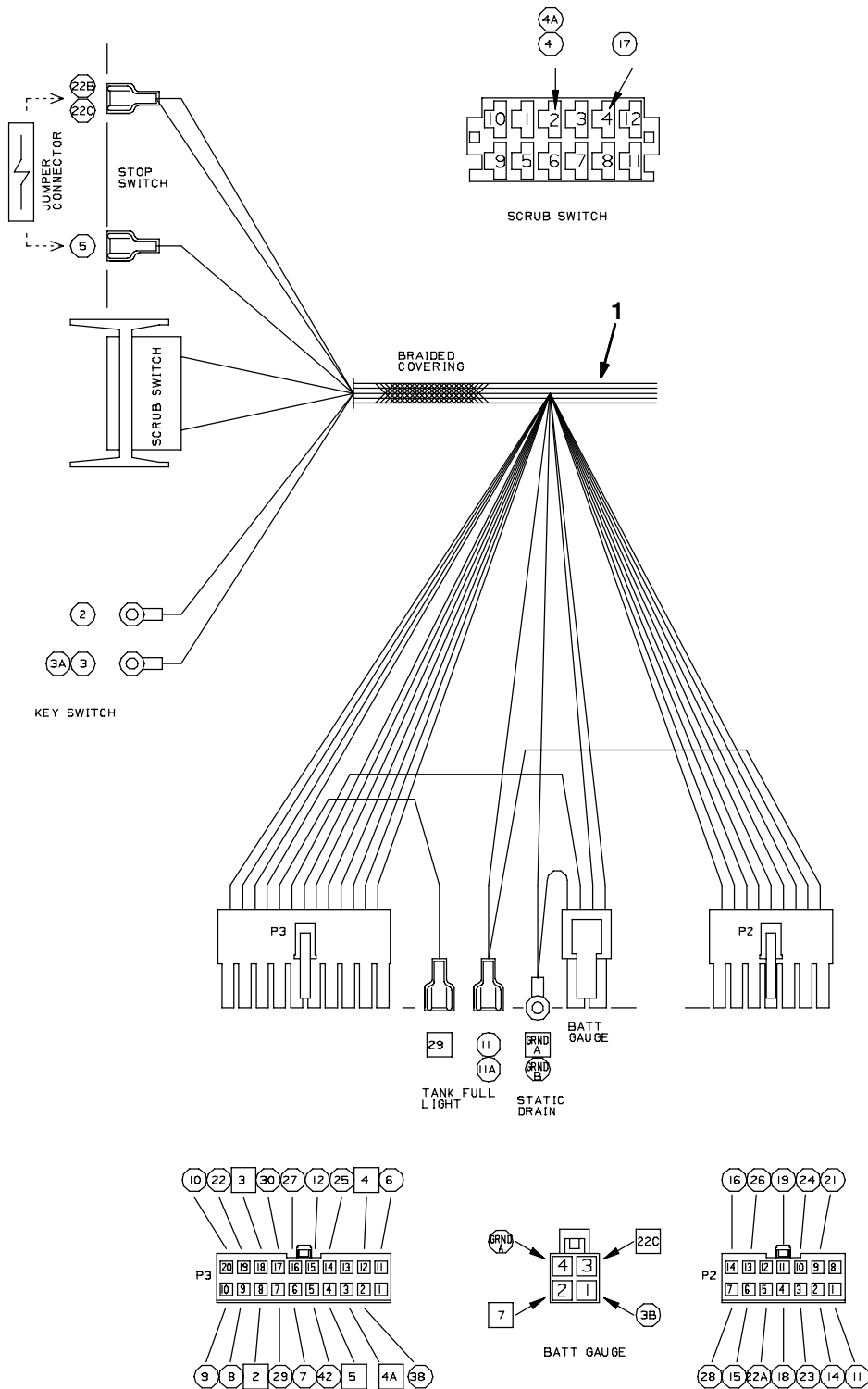

Fig. 32 - Wire Harnesses Group (10247590-)

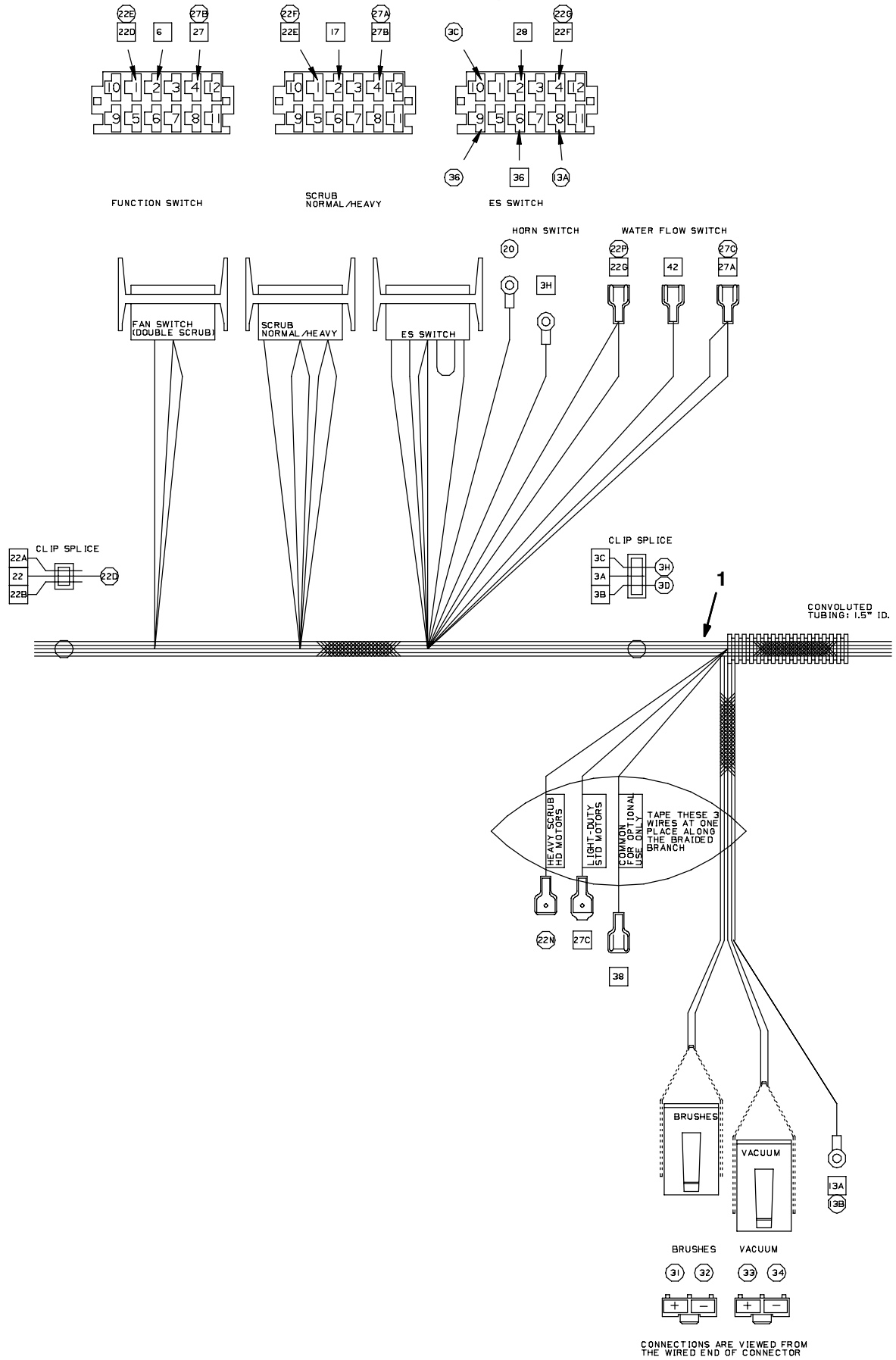
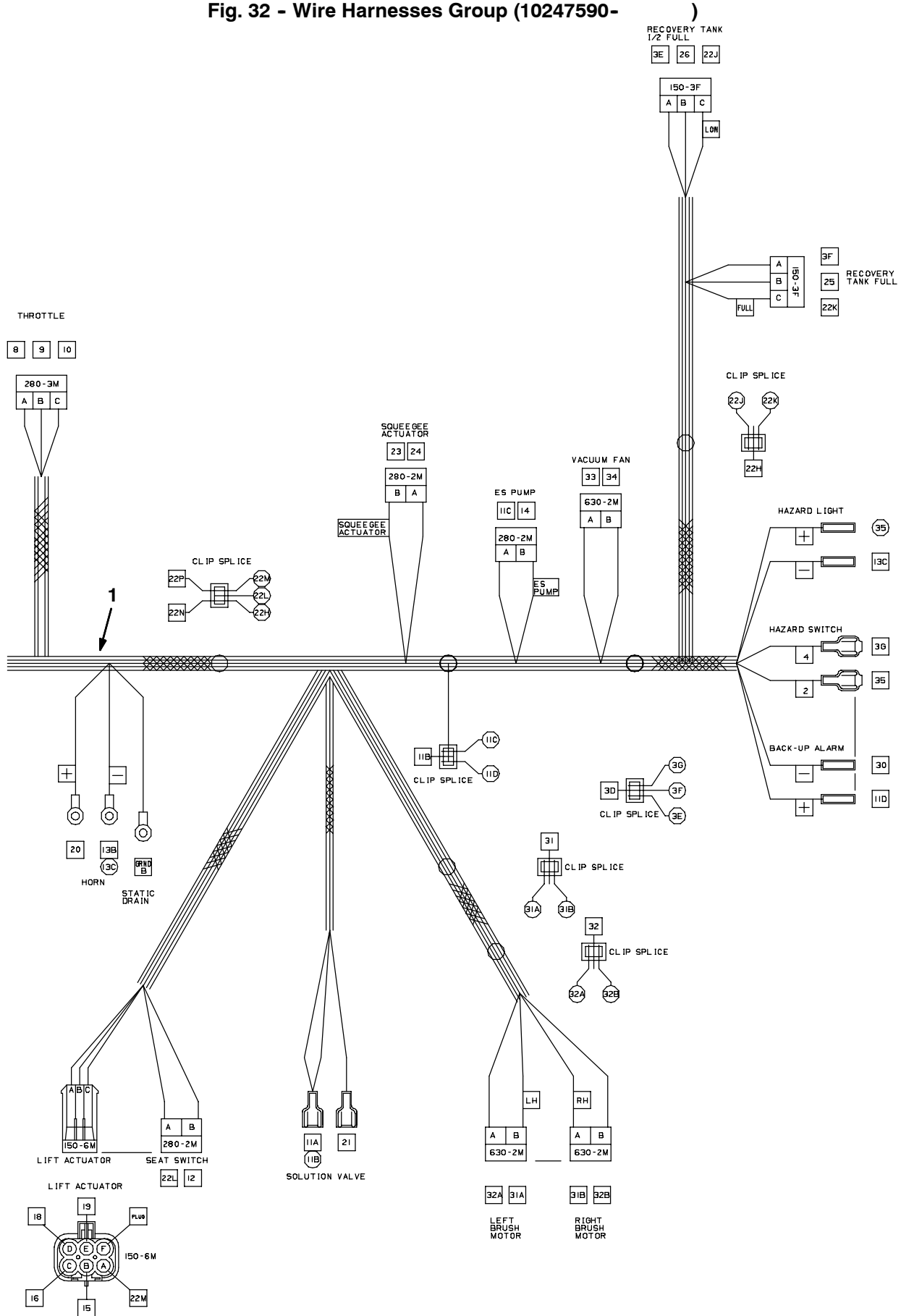
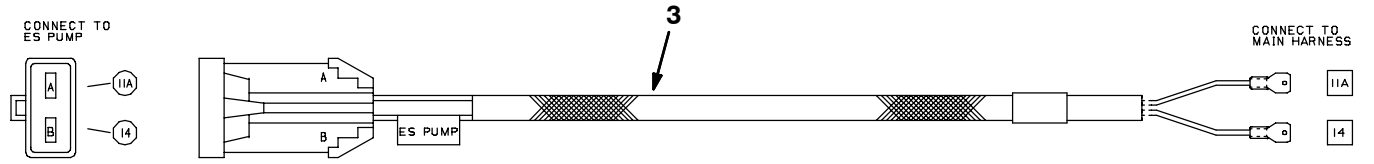
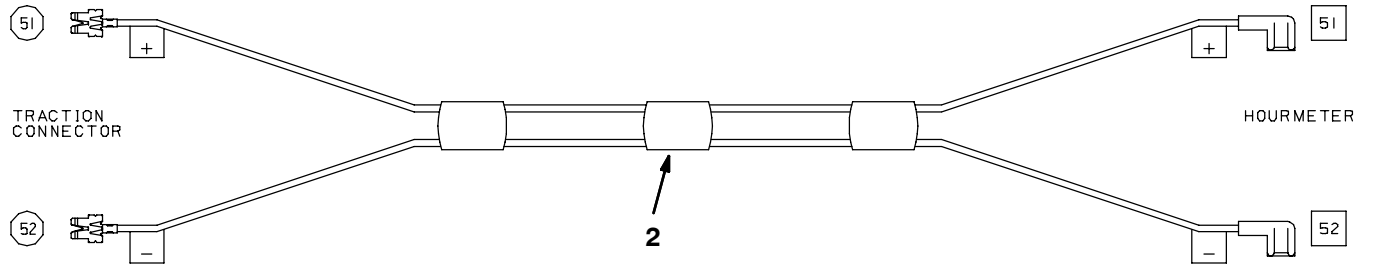

Fig. 32 - Wire Harness Group (10247590-)



353804

Fig. 32 - Wire Harnesses Group (10247590-)



354197, 353881, 353839, 353804 - EZ, 7080

Ref.	Nobles-Part No.	Description	Qty.
1	393162	③ Harness, Main, [Ezrider Hp]	1
2	393160	③ Harness, Wire, Hourmeter, Jumper	1
3	393159	③ Harness, Wire, Es Pump	1
4	393161	③ Harness, Traction, [Ezrider Hp]	1

③ Serial number (10247590-)

Fig. 33 - Label Group

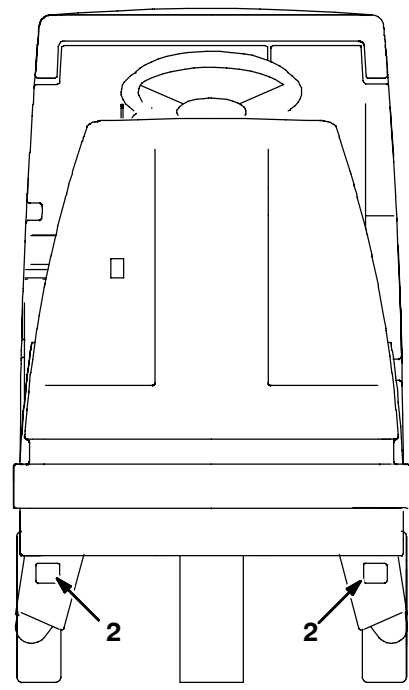
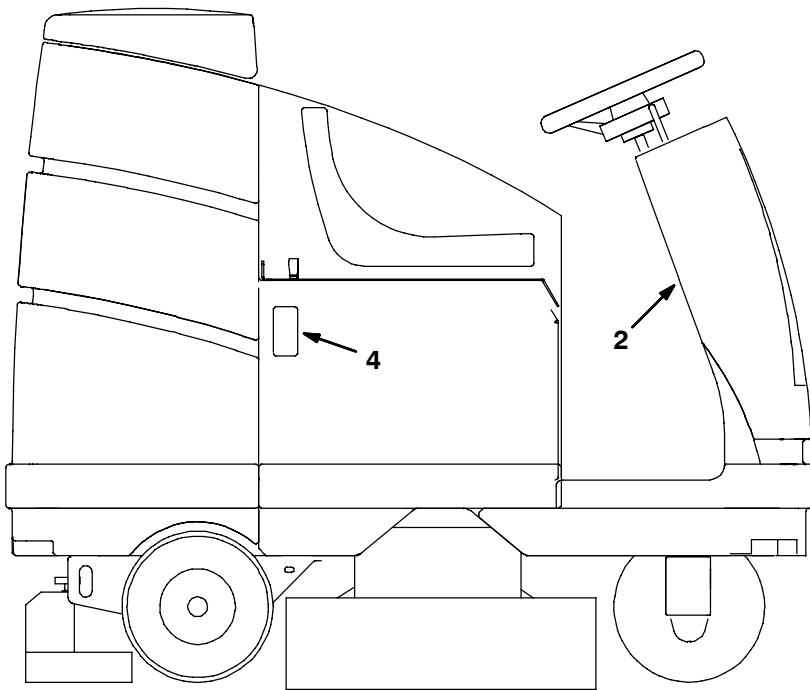
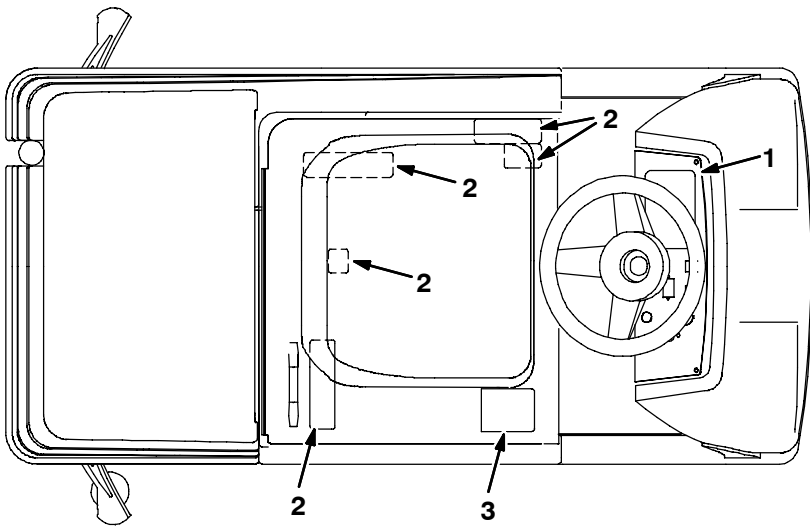

EZ, 7080

Ref.	Nobles-Part No.	Description	Qty.
1	392917	Label, Instmt [Ezrider Hp]	1
2	391297	Label Set, Info/hzrd	1
3	393143	Label, Std Opertnl	1
4	1015012	Label [Nfsi Certification]	1

SECTION 2

Contents	Page	Contents	Page
Fig. 1 - Quick Mop Kit	2-2	Fig. 20 - Cylindrical Scrub Head Drive Motor Group, 700 mm (28 in)	2-38
Fig. 2 - ES (Extended Scrub) Kit	2-4	Fig. 21 - Cylindrical Scrub Head Frame Group, 700 mm (28 in)	2-40
Fig. 3 - FaST Air Pump and Detergent Group	2-6	Fig. 22 - Cylindrical Scrub Head Squeegee Group, 700 mm (28 in)	2-42
Fig. 4 - FaST Solution Pump Group	2-8	Fig. 23 - Cylindrical Scrub Head Drive Motor Group, 800 mm (32 in)	2-44
Fig. 5 - FaST Foam Filter Group, Disk Scrub Head	2-10	Fig. 24 - Cylindrical Scrub Head Frame Group, 800 mm (32 in)	2-46
Fig. 6 - FaST Foam Filter Group, Cylindrical Scrub Head, 700 mm (28 in)	2-12	Fig. 25 - Cylindrical Scrub Head Squeegee Group, 800 mm (32 in)	2-48
Fig. 7 - FaST Foam Filter Group, Cylindrical Scrub Head, 800 mm (32 in)	2-14	Fig. 26 - Rear Squeegee Group, 800 mm (32 in)	2-50
Fig. 8 - FaST Instrument Panel Group	2-16	Fig. 27 - Revolving Light Kit	2-52
Fig. 9 - FaST Wire Harness Group	2-18	Fig. 28 - Flashing Light Kit	2-54
Fig. 10 - FaST Electrical Schematic	2-20	Fig. 29 - Backup Alarm Kit	2-56
Fig. 11 - FaST Label Group	2-21	Fig. 30 - Backup Alarm Kit W/O Bracket	2-58
Fig. 12 - Heavy Duty Disk Scrub Head Drive Motor Group, 700 mm (28 in) (00000000-10214060)	2-22	Fig. 31 - Battery Kit, Wet, 244AH	2-60
Fig. 13 - Heavy Duty Disk Scrub Head Drive Motor Group, 700 mm (28 in) (10214061-)	2-24	Fig. 32 - Battery Group, Maintenance Free, 180AH	2-61
Fig. 14 - Heavy Duty Disk Scrub Head Squeegee Group, 700 mm (28 in) (00000000-10214060)	2-26	Fig. 33 - Battery Charger Group	2-62
Fig. 15 - Heavy Duty Disk Scrub Head Squeegee Group, 700 mm (28 in) (10214061-)	2-28	Fig. 34 - Solid Non-Marking Tire Assembly, Rear	2-63
Fig. 16 - Disk Scrub Head Drive Motor Group, 800 mm (32 in) (00000000-10214060)	2-30	Fig. 35 - Documentation Group	2-64
Fig. 17 - Disk Scrub Head Drive Motor Group, 800 mm (32 in) (10214061-)	2-32		
Fig. 18 - Disk Scrub Head Squeegee Group, 800 mm (32 in) (00000000-10214060)	2-34		
Fig. 19 - Disk Scrub Head Squeegee Group, 800 mm (32 in) (10214061-)	2-36		

Fig. 1 - Quick Mop Kit

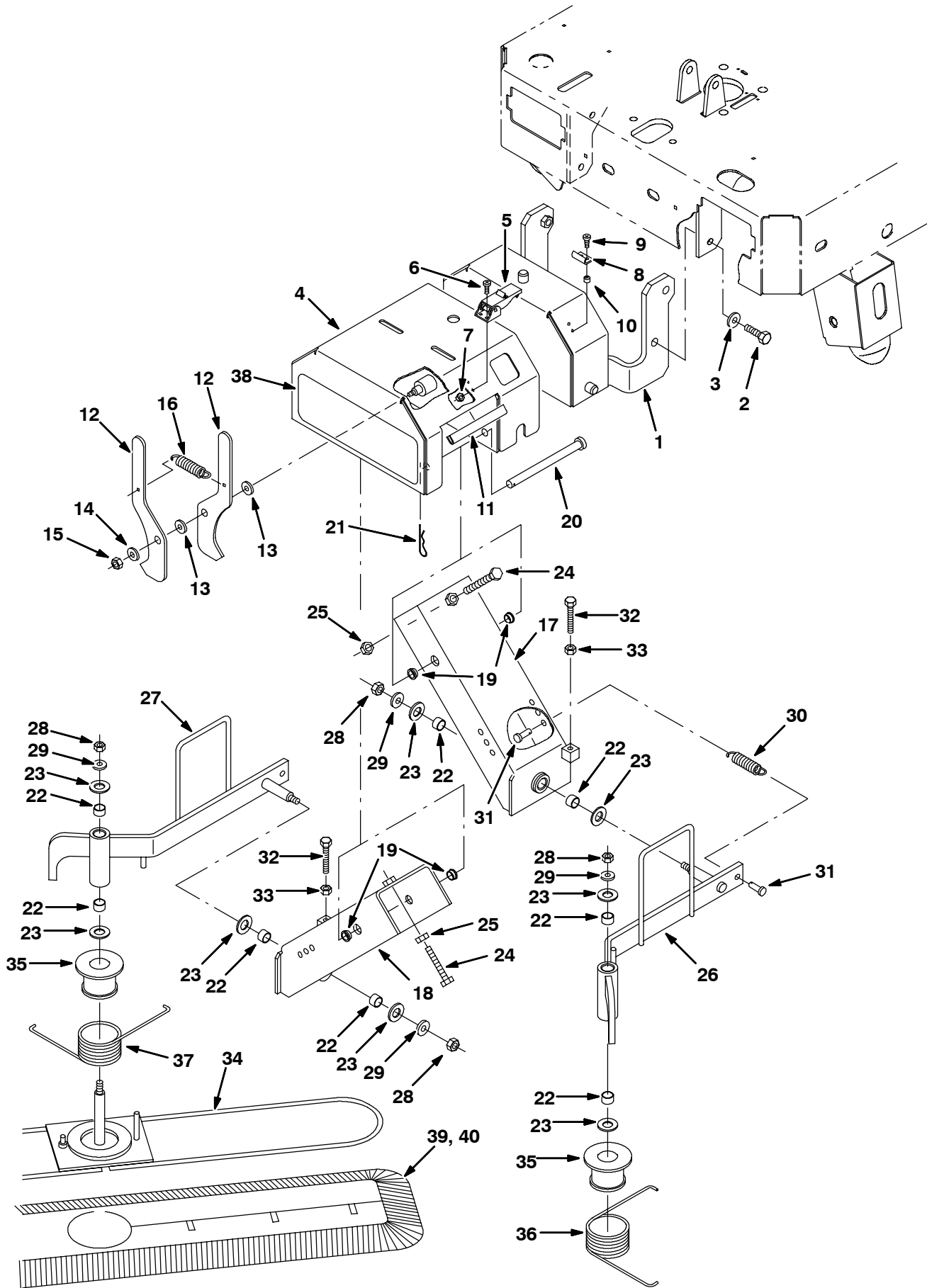

Fig. 1 - Quick Mop Kit

	Ref.	Nobles- Part No.	Description	Qty.
▽		391051	Kit, Ci, V-Mop	1
▲	1	391257	Bumper Wldt, V-Mop	1
▲	2	77347	Screw, Hex, M10 X 1.5 X 35, Ss	4
▲	3	01686	Washer, Flat, 0.44b 1.00 .08, Ss	4
▲	4	384287	Housing Wldt, Quick-Mop	1
▲	5	384418	Latch, Door	2
▲	6	49697	Screw, Pan, M04 X 0.7 X 10, Ss	4
▲	7	02850	Nut, Hex, Lock, M04 X 0.7, NI	4
▲	8	384419	Bracket, Keeper	2
▲	9	12323	Screw, Pan, M04 X 0.7 X 20, Ss	4
▲	10	65441	Spacer	4
▲	11	391287	Molding, Trim, Pvc, .08-.11 04.75l	2
▲	12	81542	Plate, Latch	2
▲	13	86860	Bearing, Thrust	2
▲	14	32491	Washer, Flt, .31 Std	1
▲	15	08709	Nut, Hex, Lock, M08 X 1.25,NI	1
▲	16	87816	Spring, Extn, 0.75od X 0.09wir, 2.5l	1
▲	17	81541	Channel Wldt, Lift, Lh	1
▲	18	81540	Channel Wldt, Lift, Rh	1
▲	19	15648	Bushing, Flng, 0.50b 0.59d 0.38l	4
▲	20	51225-1	Pin, Clevis, 0.50 D X 6.00l	2
▲	21	02942	Pin, Hair Cotter, 0.62 D .120 Wir	2
▲	22	07449	Bushing, Sleeve, 0.62b 0.72d 0.50l, Fgl	8
▲	23	64425	Washer, Thrust, 0.61b 1.25d .06, Fgl	8
▲	24	76438	Screw, Hex, M10 X 1.5 X 90, FI	2
▲	25	39312	Nut, Hex, Std, M10 X 1.5	2
▲	26	81539	Arm Wldt, Lift, Mop, Lh	1
▲	27	81538	Arm Wldt, Lift, Mop, Rh	1
▲	28	41430	Nut, Hex, Lock, M10 X 1.5, NI	4
▲	29	32492	Washer, Flt, .38 Std	4
▲	30	15047	Spring, Extn, 0.62od X 0.08wir, 3.0l	2
▲	31	39019	Pin, Clevis, 0.37 D X 0.75l	4
▲	32	363976	Screw, Hex, M08 X 1.25 X 60, FI	2
▲	33	39311	Nut, Hex, Std, M08 X 1.25	2
▲	34	81537	Frame Wldt, Mop, V	2
▲	35	83332	Spacer, Spring	2
▲	36	80317	Spring, Tors, 2.36id .18wir 07.5coil	1
▲	37	80318	Spring, Tors, 2.36id .18wir 07.5coil	1
▲	38	384265	Label, [Quick Mop]	1
▲	39	83347	Mop, Dust	2
	40	83348	Mop, Dust, Industrial	1

▽ ASSEMBLY

▲ INCLUDED IN ASSEMBLY

Fig. 2 - ES (Extended Scrub) Kit

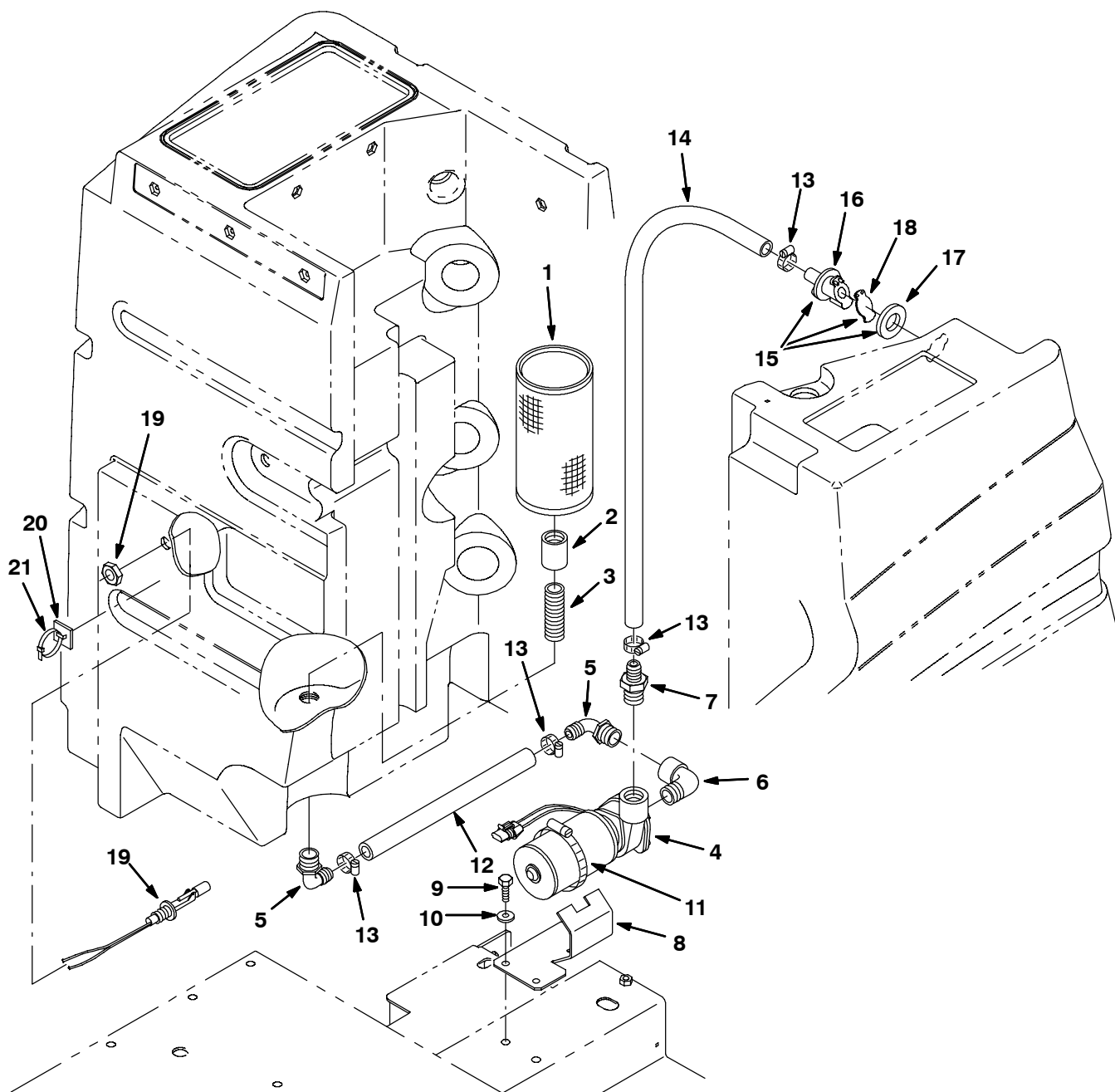

Fig. 2 - ES (Extended Scrub) Kit

	Ref.	Nobles- Part No.	Description	Qty.
▽		392946	Kit, Di, Es [Ezrider Hp/7080]	1
▲	1	10573	Strainer, Soltn, 20mesh Cyl 4.0d 8.0l	1
▲	2	05134	Fitting, Plstc, Str, Pf12/Pf12	1
▲	3	385665	Fitting, Plstc, Str, Pm12/Pm12 03.0l	1
▲	4	369865	Pump, Solution, Impeller, 36vdc	1
▲	5	73468	Fitting, Plstc, E90, Bm10/Pm12	2
▲	6	69785	Fitting, Plstc, E90, Pm12/Pf12	1
▲	7	365095	Fitting, Plstc, Str, Bm10/Pm12	1
▲	8	391115	Bracket, Pump, Es	1
▲	9	49826	Screw, Hex, M08 X 1.25 X 16, Ss, NI	2
▲	10	01685	Washer, Flat, .31 Ss	2
▲	11	17188	Clamp, Hose, Wormdrive, 1.62-3.50d	1
▲	12	393100	Hose, PVC, Brd, 0.62id 0.96od 6.50L (C460117)	6.500'
▲	13	63810	Clamp, Hose, Wormdrive, 0.56-1.06d	4
▲	14	393102	Hose, PVC, Brd, 0.62id 0.96od 6.50L (C460117)	6.500'
▲▽	15	78842	Kit, Valve, Check	1
▲▲	16	78840	Valve, Check	1
▲▲	17	73342	Gasket, Check, Valve	1
▲▲	18	78841	Flapper, Valve	1
▲	19	222822	Sensor, Level, Liquid [Magnetic]	1
▲	20	55248	Mount, Cable Tie	1
▲	21	49266	Tie, Cable, Nyl, 07.3L .19W 1.8 Max D	1

▽ ASSEMBLY

▲ INCLUDED IN ASSEMBLY

Fig. 3 - FaST Air Pump and Detergent Group

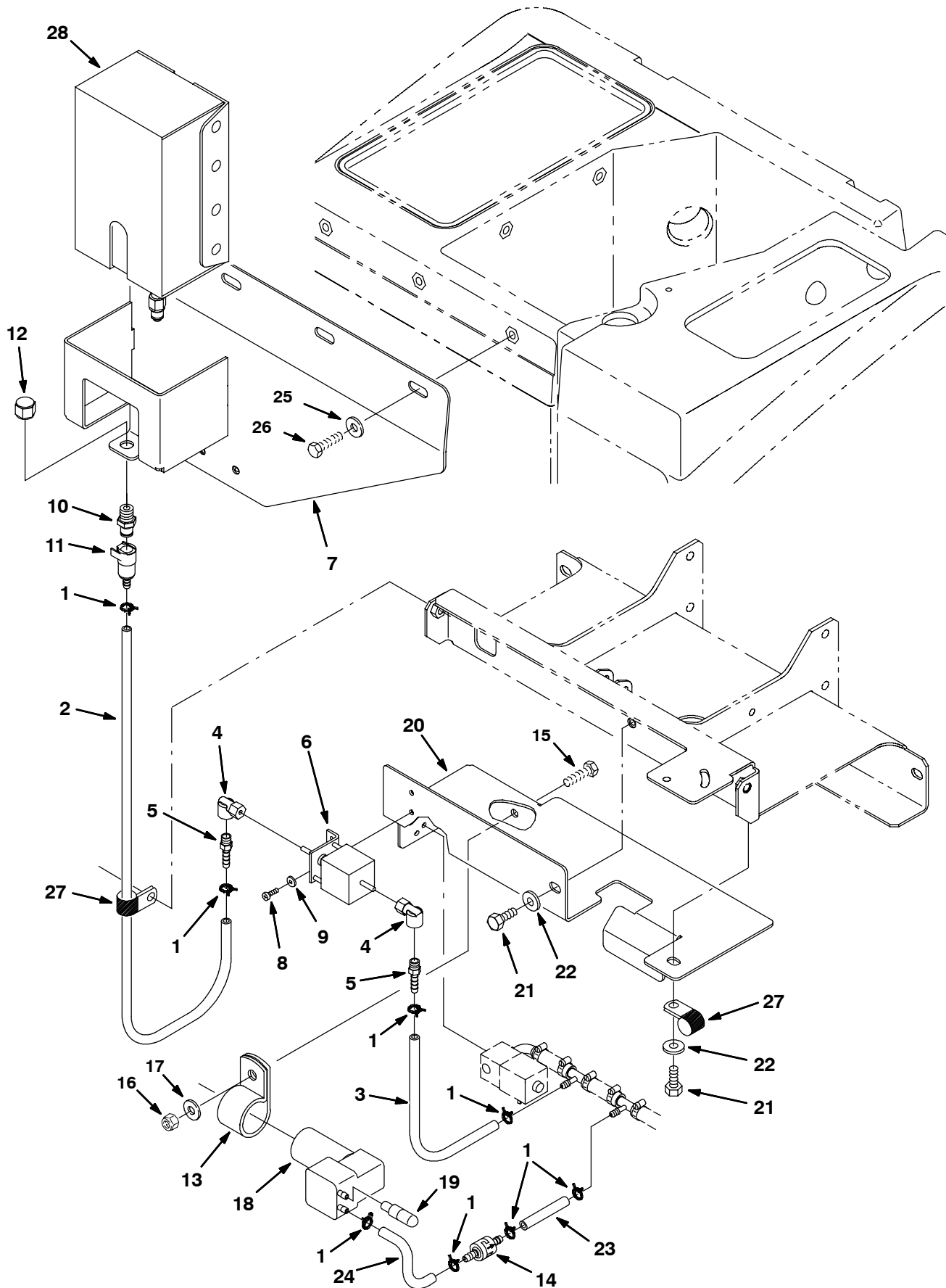

Fig. 3 - FaST Air Pump and Detergent Group

Ref.	Nobles-Part No.	Description	Qty.	
1	613735	☐ Clamp, Hose .40 - .42 2 Wire	8	
2	1006415	☐ Hose, Afmkt, Pvc, Clr 0.25id 3ft (C460126)	3.000'	
3	613727	☐ Hose, .25id X 12" Pvc (C460126)	0.540'	
4	1014082	☐ Fitting, Brs, E90, Cf03/Pf02	2	
5	150525	☐ Fitting, Brs, Str, Pm02/Bm04	2	
6	1013789	☐ Pump, Detgt [560s]	1	
7	1012831	☐ Bracket Wldt, Box Detgt	1	
8	06927	☐ Screw, Pan, M4 X 0.7 X 16, 4.8	2	
9	19064	☐ Washer, Flat, #06	2	
10	1006206	☐ Fitting, Plstc, Str, Pm04, Cplg, Male	1	
11	1006204	☐ Coupling, Fem, W/Valve, .25 Brb	1	
12	1005435	☐ Fitting, Plstc, Cap, Pf04	1	
13	53466	☐ Clamp, Cable, Stl, 1.50d X 1.00w, 1h	1	
14	1013902	☐ Valve, Check, 2 Gpm 2 Psi Bm04/Bm04	1	
15	09010	☐ Screw, Hex, M8 X 1.25 X 25, Ss	1	
16	08713	☐ Nut, Hex, Lock, M 8 X 1.25, NI, Ss	1	
17	01685	☐ Washer, Flat, 0.31 Ss	1	
▽	18	1008211	☐ Pump, Air, Ele, 36vdc	1
▲		391449	☐ Kit, Repair, Diaphragm, Air Compressor	1
	19	1005255	☐ Filter Assy, Air, Molded Ure	1
	20	1015365	☐ Bracket	1
	21	09740	☐ Screw, Hex, M8 X 1.25 X 20, Ss	3
	22	01685	☐ Washer, Flat, 0.31 Ss	3
	23	613727	☐ Hose, .25id X 12" Pvc (C460126)	0.440'
	24	613727	☐ Hose, .25id X 12" Pvc (C460126)	0.104'
	25	01685	☐ Washer, Flt, .31 Ss	3
	26	15675	☐ Screw, Hex, M08 X 1.25 X 20, Ss	3
	27	82829	☐ Clamp, Cable, Stl, 0.63d X 0.75w, 1h	2
	28	1017019	☐ Detergent Pkg, 2 Liter, Sgl. (MP)	1
		1017025	☐ Detergent Pkg, 2 Liter, Sgl. (MPD)	1

☐ Serial number (10179742-)

▽ ASSEMBLY

▲ INCLUDED IN ASSEMBLY

Fig. 4 - FaST Solution Pump Group

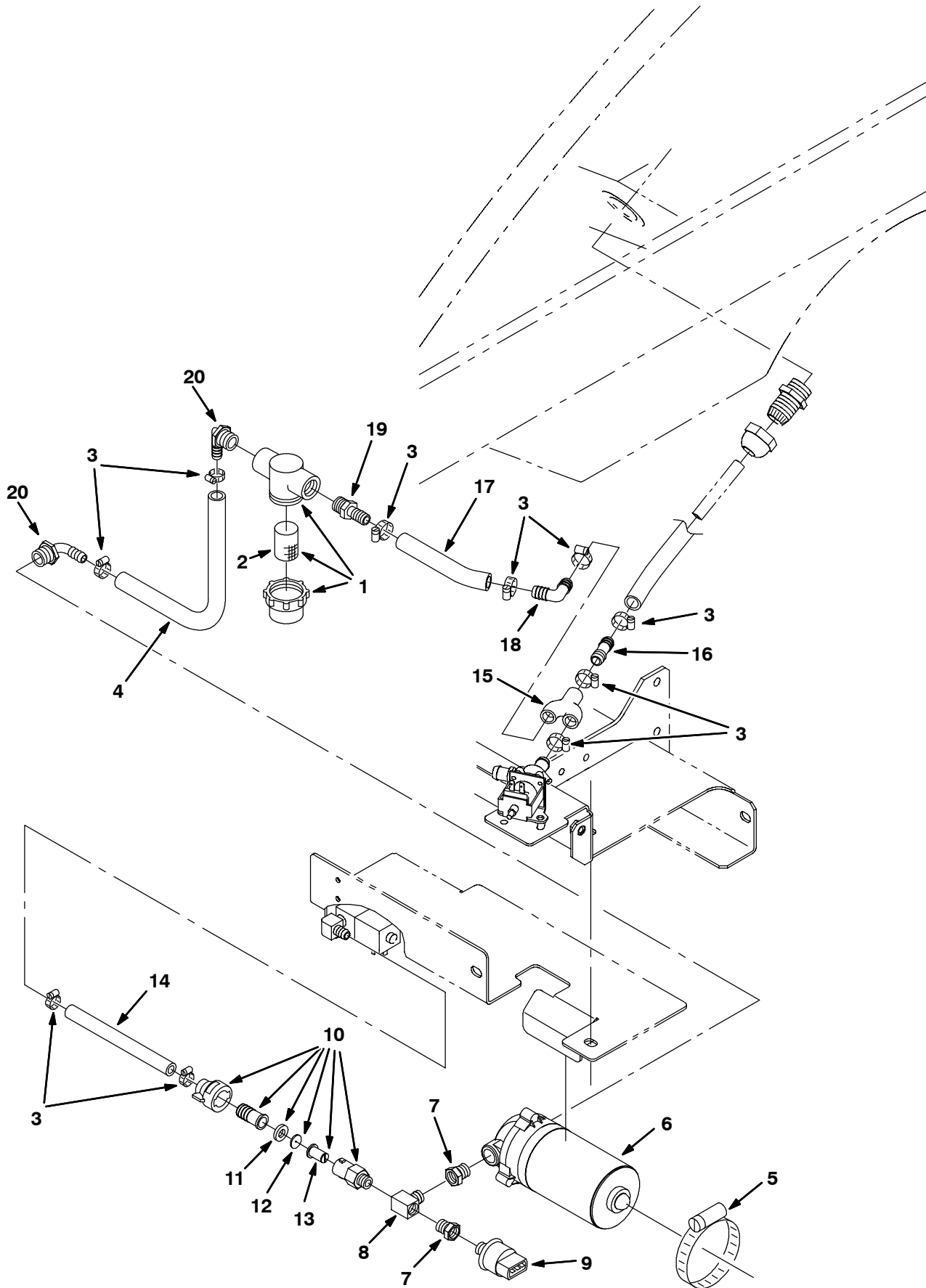

Fig. 4 - FaST Solution Pump Group

	Ref.	Nobles- Part No.		Description	Qty.
∇	1	1005302	①	Filter, Inline, Pf06/Pf06, 80 Mesh	1
▲	2	1005304	①	Screen, Fltr, 80 Mesh	1
	3	54333	①	Clamp, Hose, Wormdrive, 0.31-0.88d	10
	4	1011521	①	Hose, Afmkt Pvc, Brd 0.50id X 2 Ft (376716)	1.750'
	5	17188	①	Clamp, Hose, Wormdrive, 1.62-3.50d	1
	6	1005866	①	Pump, Soltn, Ele, 36vdc	1
	7	150100	①	Fitting, Brs, Str, Pm04/Pf02	2
	8	53268	①	Fitting, Brs, Tee, Pf04/Pm04/Pf04	1
	9	1014436	①	Switch, Press, 10psi, Spst	1
∇	10	1014675	①	Fitting Assy, Cap, 0.045b, Pm04/Bm08	1
▲	11	1005508	①	Washer, Flat, .34b .75d .12, Viton	1
▲	12	1014011	①	Plate, Orifice, 0.045id	1
▲	13	1006447	①	Screen, 50 Mesh, Ss	1
	14	1011403	①	Hose, Afmkt Pvc, Brd 0.50id X 1 Ft (376716)	0.590'
	15	1013935	①	Fitting, Vyl, Y, Formed, 0.5id	1
	16	364631	①	Fitting, Plstc, Str, Bm08/Bm08	1
	17	1011403	①	Hose, Afmkt Pvc, Brd 0.50id X 1 Ft (376716)	0.500'
	18	63987-1	①	Fitting, Plstc, E90, Bm08/Bm08	1
	19	64743	①	Fitting, Plstc, Str, Bm08/Pm06	1
	20	64778	①	Fitting, Plstc, E90, Bm08/Pm06	2

① Serial number (10179742-)

∇ ASSEMBLY

▲ INCLUDED IN ASSEMBLY

Fig. 5 - FaST Foam Filter Group, Disk Scrub Head

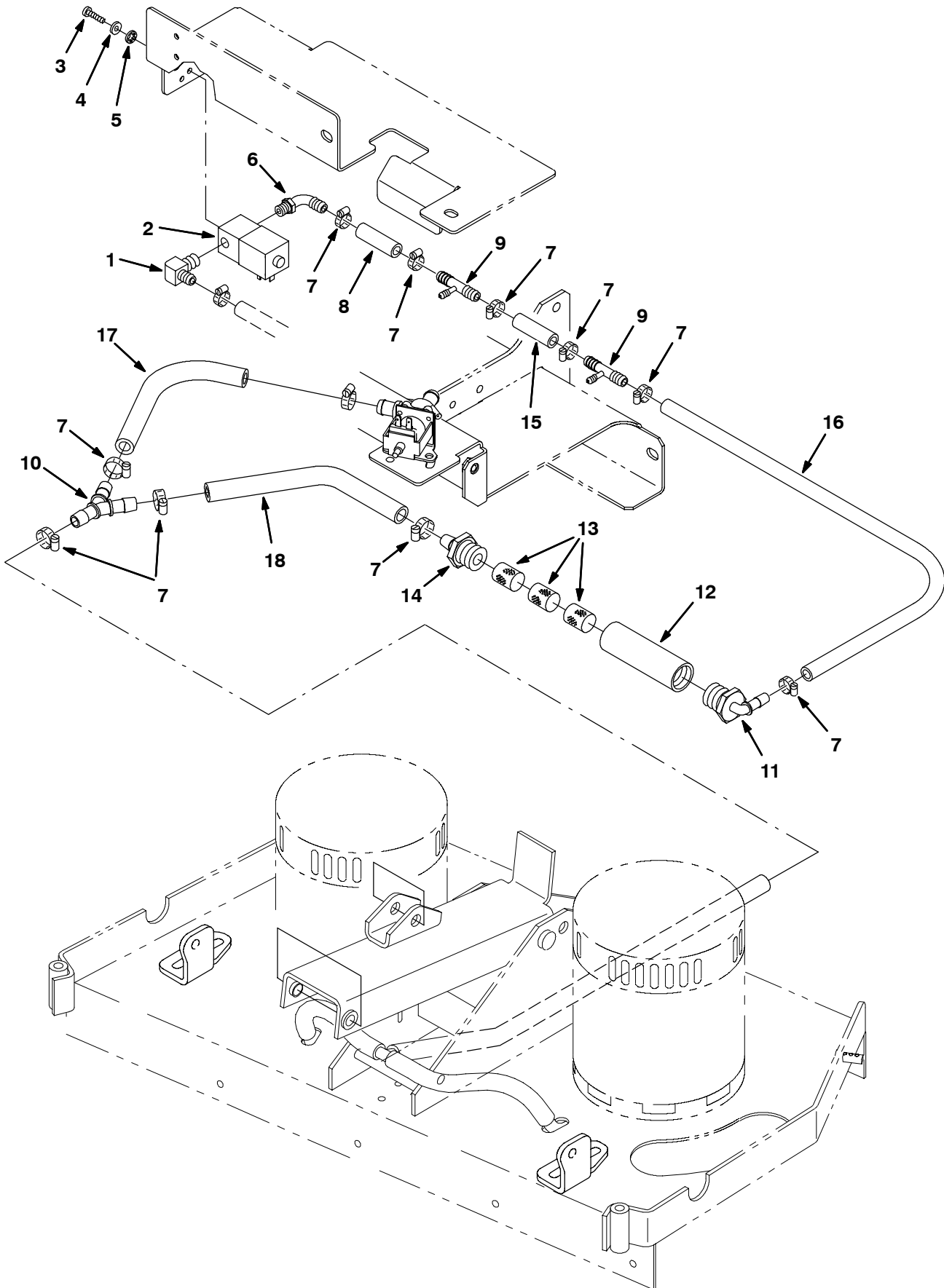

Fig. 5 - FaST Foam Filter Group, Disk Scrub Head

Ref.	Nobles- Part No.	Description	Qty.
1	1010836	① Fitting, Brs, E90, Pm04/Bm08	1
2	1009603	① Valve, Water, Sol , 36vdc 02pf	1
3	06932	① Screw, Pan, M5 X 0.8 X 10, 4.8	2
4	19324	① Washer, Flat, #10 Sae	2
5	32980	① Washer, Lock, Int, #10	2
6	1010713	① Fitting, Plstc, E90, Bm08/Pm04	1
7	54333	① Clamp, Hose, Wormdrive, 0.31-0.88d	10
8	1011403	① Hose, Afmkt Pvc, Brd 0.50id X 1 Ft (376716)	0.250'
9	1010684	① Fitting, Plstc, Tee, Bm08/Bm04/Bm08	2
10	1010668	① Fitting, Plstc, Y, Bm08/Bm08/Bm08 Nyl	1
11	1005552	① Fitting, Plstc, E90, Bm08/Pm12, Nyl	1
12	1005086	① Tube, Pvc, Shc80, Clear, 4.0l	1
13	1002789	① Filter, Foam	3
14	79273-1	① Fitting, Plstc, Str, Bm08/Pm12	1
15	1011403	① Hose, Afmkt Pvc, Brd 0.50id X 1 Ft (376716)	0.500'
16	1011521	① Hose, Afmkt Pvc, Brd 0.50id X 2 Ft (376716)	1.420'
17	1015033	① Hose, Afmkt Pvc, Brd 0.62id X 1 Ft (C460117)	1.000'
18	1015033	① Hose, Afmkt Pvc, Brd 0.62id X 1 Ft (C460117)	0.250'

① Serial number (10179742-)

Fig. 6 - FaST Foam Filter Group, Cylindrical Scrub Head, 700 mm (28 in)

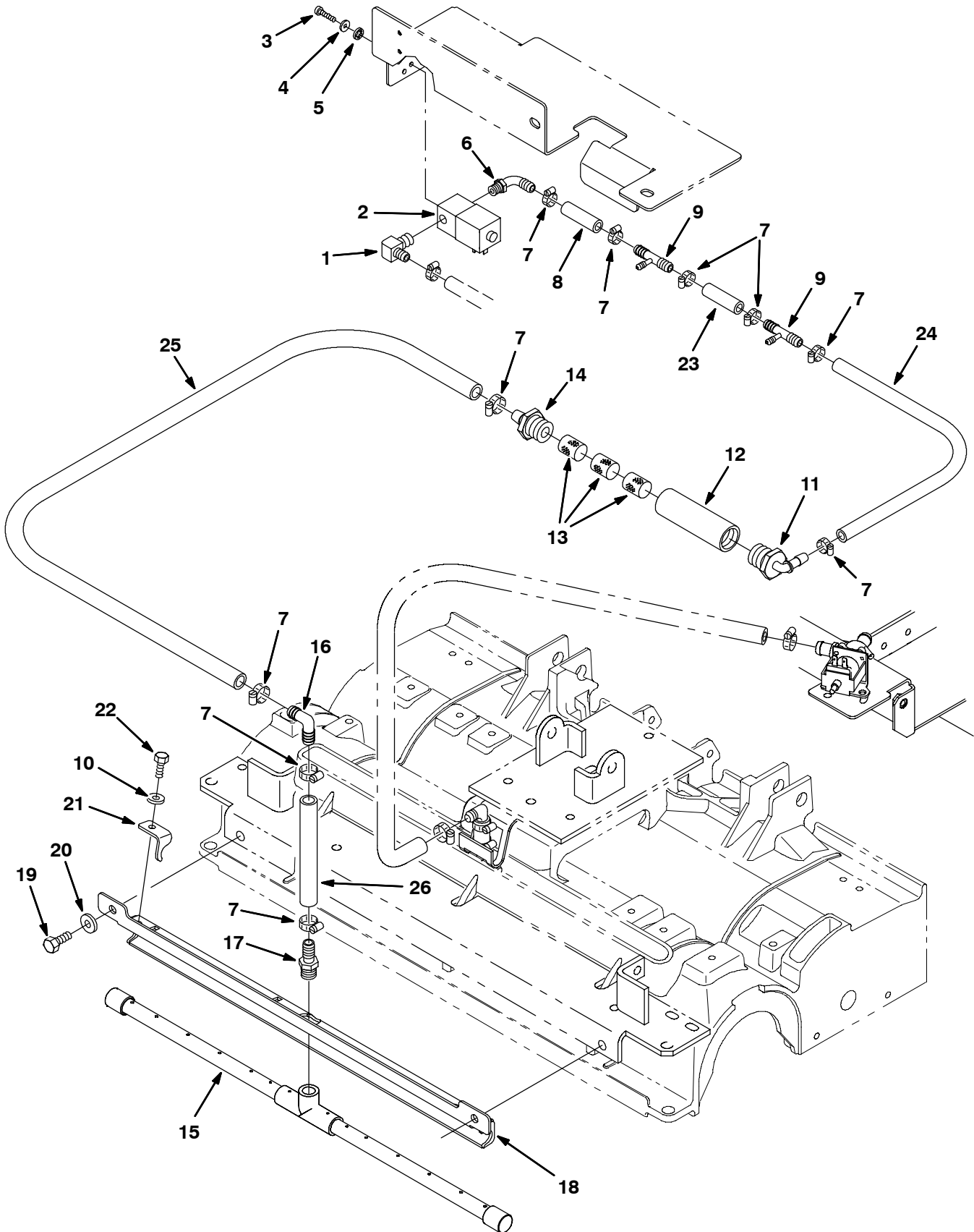

Fig. 6 - FaST Foam Filter Group, Cylindrical Scrub Head, 700 mm (28 in)

Ref.	Nobles- Part No.	Description	Qty.
1	1010836	① Fitting, Brs, E90, Pm04/Bm08	1
2	1009603	① Valve, Water, Sol , 36vdc 02pf	1
3	06932	① Screw, Pan, M5 X 0.8 X 10, 4.8	2
4	19324	① Washer, Flat, #10 Sae	2
5	32980	① Washer, Lock, Int, #10	2
6	1010713	① Fitting, Plstc, E90, Bm08/Pm04	1
7	54333	① Clamp, Hose, Wormdrive, 0.31-0.88d	10
8	1011403	① Hose, Afmkt Pvc, Brd 0.50id X 1 Ft (376716)	0.250'
9	1010684	① Fitting, Plstc, Tee, Bm08/Bm04/Bm08	2
10	01684	① Washer, Flat, 0.25 Ss	3
11	1005552	① Fitting, Plstc, E90, Bm08/Pm12, Nyl	1
12	1005086	① Tube, Pvc, Shc80, Clear, 4.0l	1
13	1002789	① Filter, Foam	3
14	79273-1	① Fitting, Plstc, Str, Bm08/Pm12	1
15	1014791	① Tube Assy, Bar, Spray 700mm [7100]	1
16	63987-1	① Fitting, Plstc, E90, Bm08/Bm08	1
17	64743	① Fitting, Plstc, Str, Bm08/Pm06	1
18	1014993	① Bracket Wldt, Bar, Spray, 700mm [7100]	1
19	12273	① Screw, Hex, M8 X 1.25 X 20, Ss, NI	2
20	01685	① Washer, Flat, 0.31 Ss	2
21	1014673	① Bracket, Bar, Spray	3
22	11635	① Screw, Hex, M6 X 1.0 X 12, Ss, NI	3
23	1011403	① Hose, Afmkt Pvc, Brd 0.50id X 1 Ft (376716)	0.500'
24	1011521	① Hose, Afmkt Pvc, Brd 0.50id X 2 Ft (376716)	1.420'
25	1011521	① Hose, Afmkt Pvc, Brd 0.50id X 2 Ft (376716)	1.080'
26	1011403	① Hose, Afmkt Pvc, Brd 0.50id X 1 Ft (376716)	0.460'

① Serial number (10179742-)

Fig. 7 - FaST Foam Filter Group, Cylindrical Scrub Head, 800 mm (32 in)

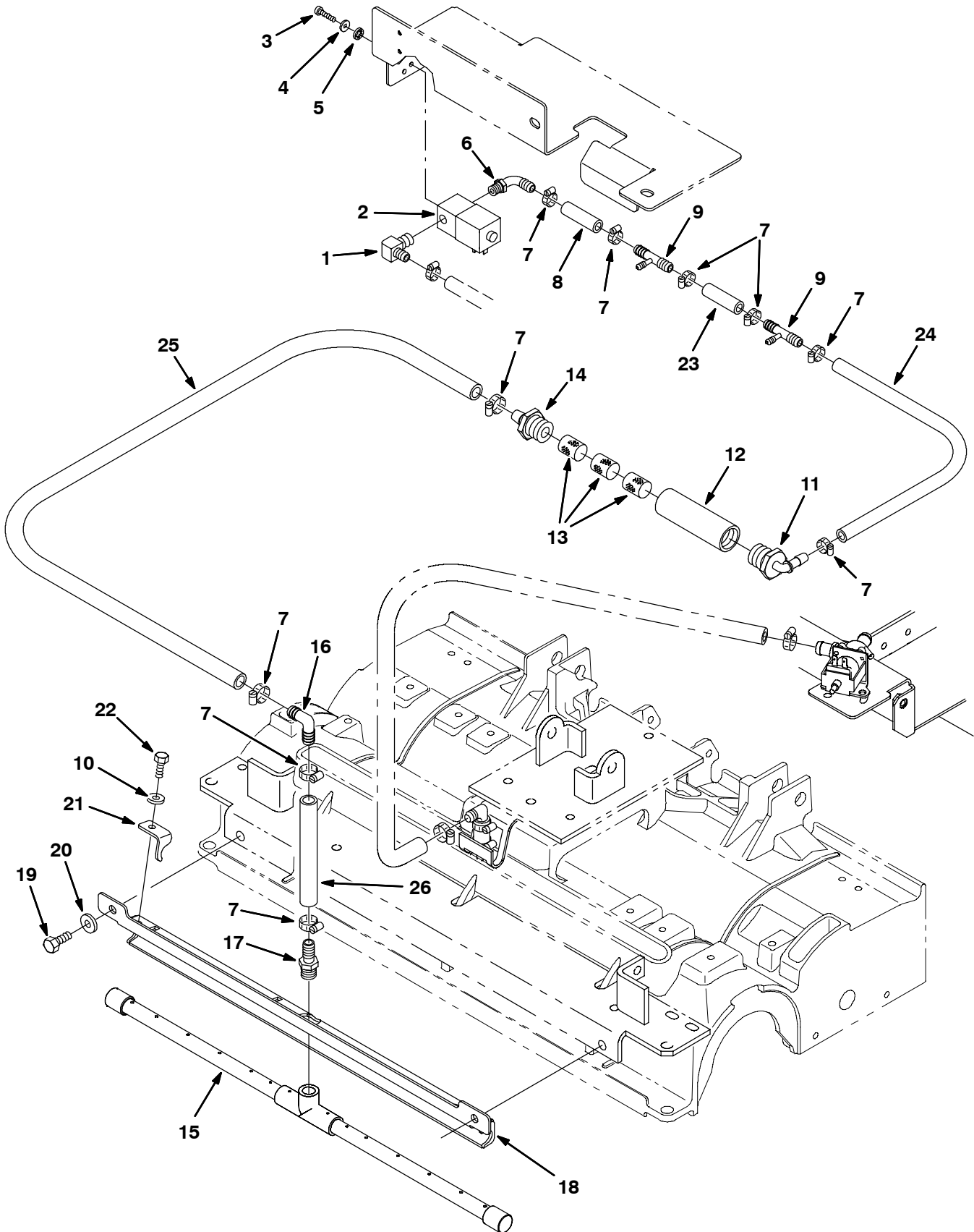

Fig. 7 - FaST Foam Filter Group, Cylindrical Scrub Head, 800 mm (32 in)

Ref.	Nobles- Part No.	Description	Qty.
1	1010836	① Fitting, Brs, E90, Pm04/Bm08	1
2	1009603	① Valve, Water, Sol , 36vdc 02pf	1
3	06932	① Screw, Pan, M5 X 0.8 X 10, 4.8	2
4	19324	① Washer, Flat, #10 Sae	2
5	32980	① Washer, Lock, Int, #10	2
6	1010713	① Fitting, Plstc, E90, Bm08/Pm04	1
7	54333	① Clamp, Hose, Wormdrive, 0.31-0.88d	10
8	1011403	① Hose, Afmkt Pvc, Brd 0.50id X 1 Ft (376716)	0.250'
9	1010684	① Fitting, Plstc, Tee, Bm08/Bm04/Bm08	2
10	01684	① Washer, Flat, 0.25 Ss	3
11	1005552	① Fitting, Plstc, E90, Bm08/Pm12, Nyl	1
12	1005086	① Tube, Pvc, Shc80, Clear, 4.0l	1
13	1002789	① Filter, Foam	3
14	79273-1	① Fitting, Plstc, Str, Bm08/Pm12	1
15	1013079	① Tube Assy, Spray, Cyl 800mm [7100]	1
16	63987-1	① Fitting, Plstc, E90, Bm08/Bm08	1
17	64743	① Fitting, Plstc, Str, Bm08/Pm06	1
18	1014957	① Bracket Wldt, Bar, Spray, 800mm [7100]	1
19	12273	① Screw, Hex, M8 X 1.25 X 20, Ss, NI	2
20	01685	① Washer, Flat, 0.31 Ss	2
21	1014673	① Bracket, Bar, Spray	3
22	11635	① Screw, Hex, M6 X 1.0 X 12, Ss, NI	3
23	1011403	① Hose, Afmkt Pvc, Brd 0.50id X 1 Ft (376716)	0.500'
24	1011521	① Hose, Afmkt Pvc, Brd 0.50id X 2 Ft (376716)	1.420'
25	1011521	① Hose, Afmkt Pvc, Brd 0.50id X 2 Ft (376716)	1.080'
26	1011403	① Hose, Afmkt Pvc, Brd 0.50id X 1 Ft (376716)	0.460'

① Serial number (10179742-)

Fig. 8 - FaST Instrument Panel Group

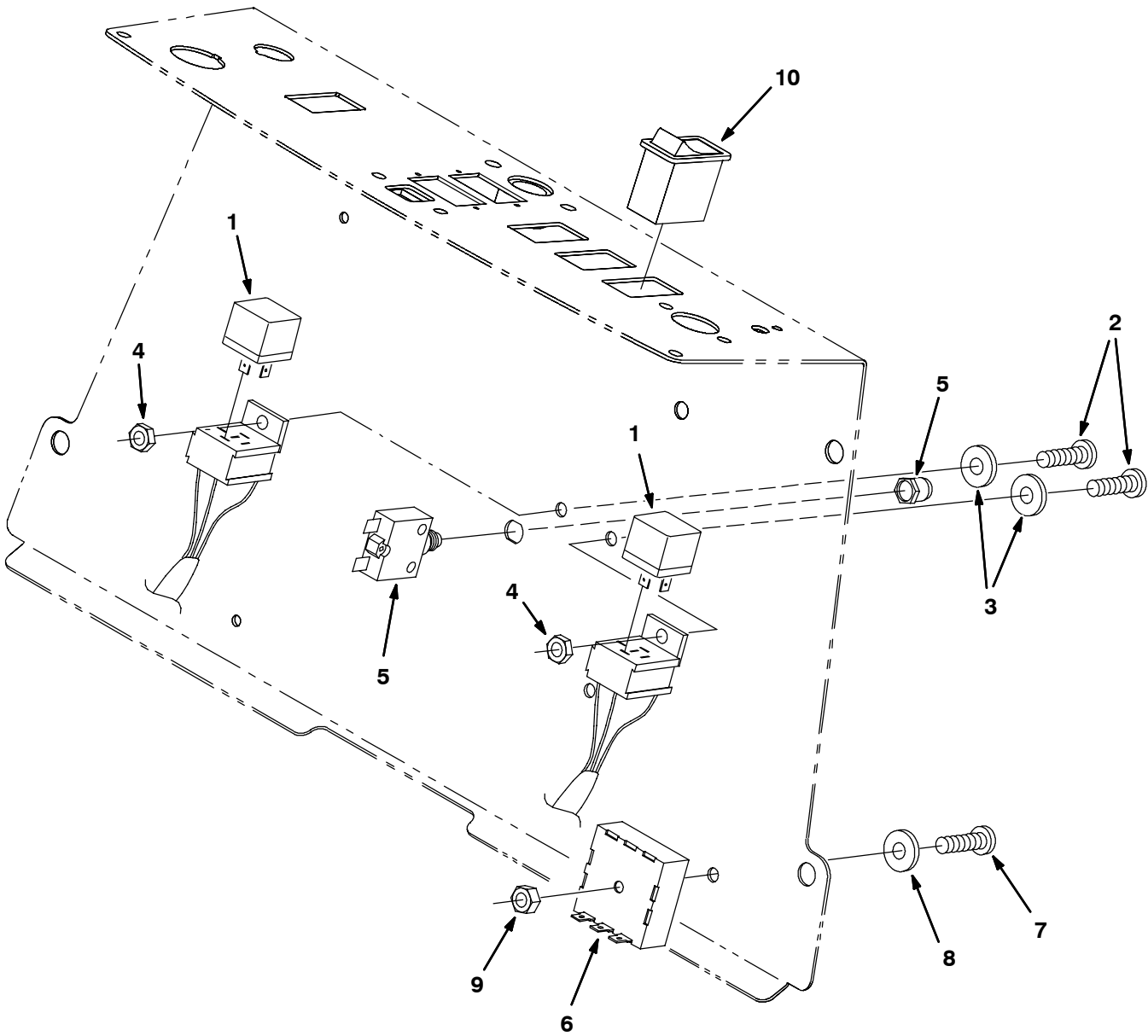
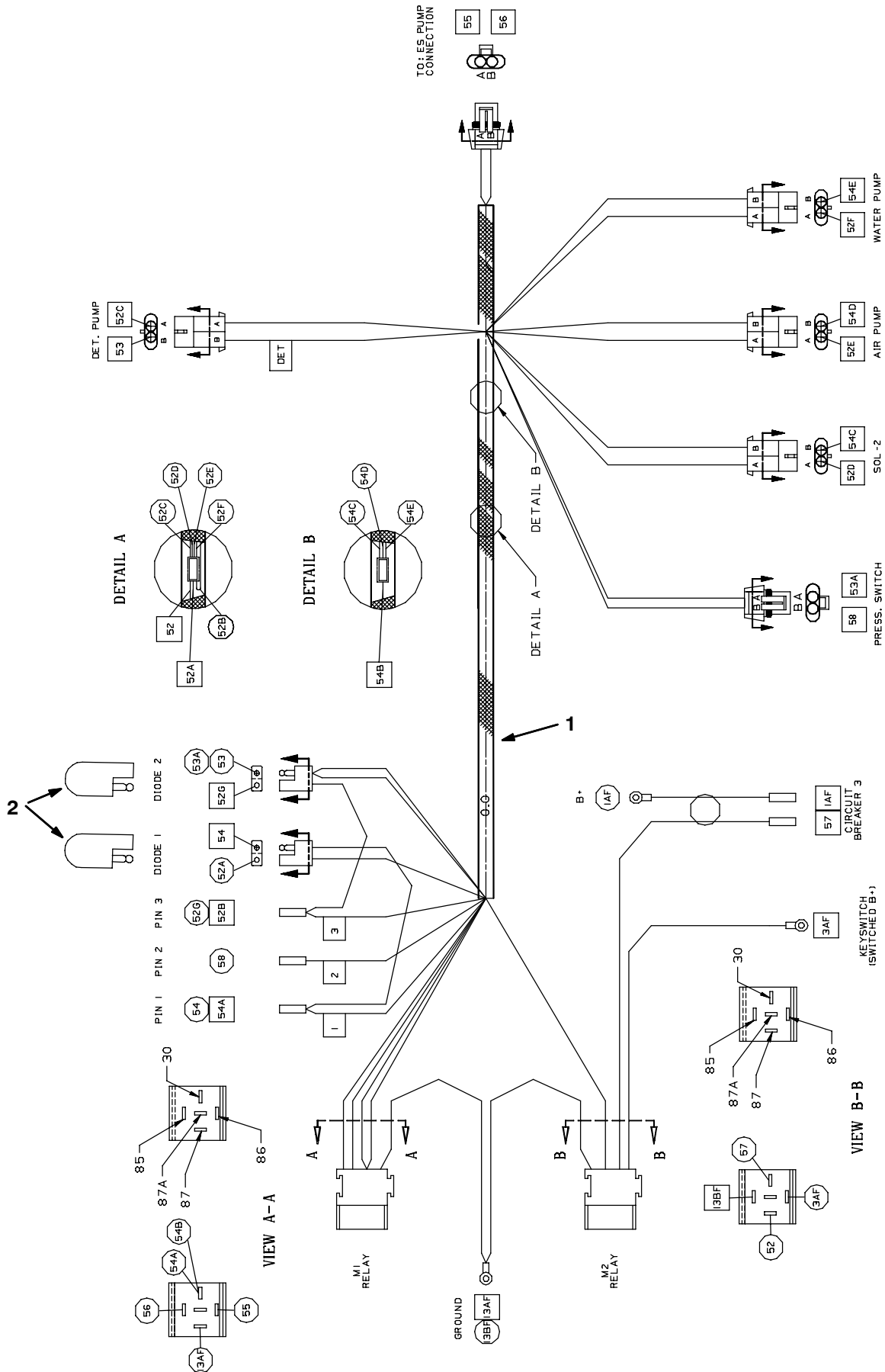

Fig. 8 - FaST Instrument Panel Group

Ref.	Nobles- Part No.		Description	Qty.
1	398526	①	Relay, 36vdc, 05a, Spdt N/O [Greenwich]	1
2	06932	①	Screw, Pan, M5 X 0.8 X 10, 4.8	2
3	19066	①	Washer, Flt, #10	2
4	06549	①	Nut, Hex, Lock, M 5 X 0.8, NI	2
5	383721	①	Circuitbreaker, 10.0a	1
6	1005199	①	Module, Timer, Detgt, 36vdc	1
7	33944	①	Screw, Pan, M6 X 1.0 X 35, 4.8	1
8	32490	①	Washer, Flat, 0.25 Std	1
9	08708	①	Nut, Hex, Lock, M 6 X 1.0, NI	1
10	397889	①	Switch, Rocker, 36vdc 05a Dpst On/N/On	1

① Serial number (10179742-)

Fig. 9 - FaST Wire Harness Group



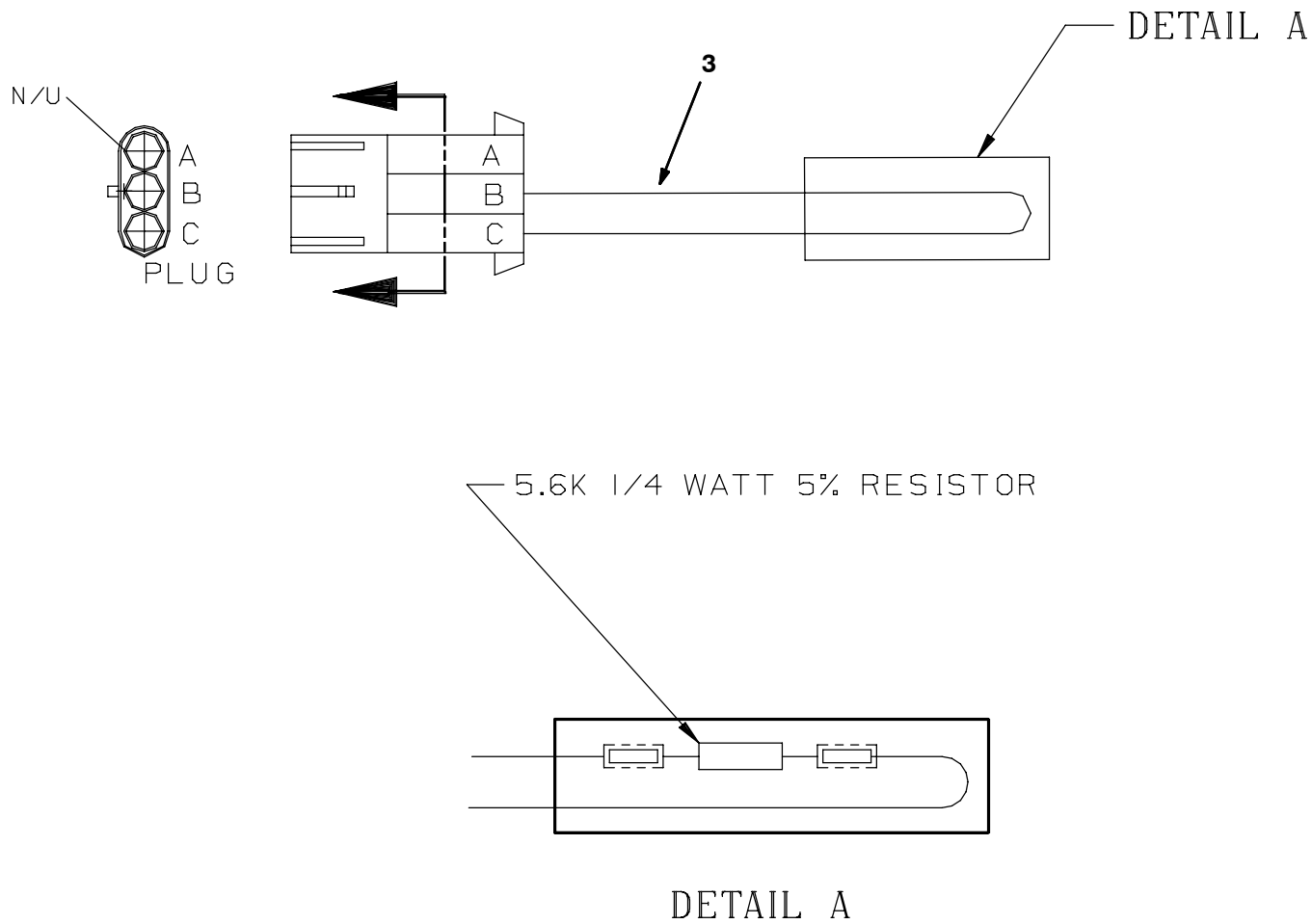

Fig. 9 - FaST Wire Harness Group

354245, 354247

Ref.	Nobles- Part No.	Description	Qty.
1	391911	1 Harness [Ez Rider Hp Fast]	1
2	222290	1 Diode, Ele, Plug	2
3	391899	1 Harness [Fast Ezriderhp]	1

1 Serial number (10179742-)

Fig. 10 - FaST Electrical Schematic

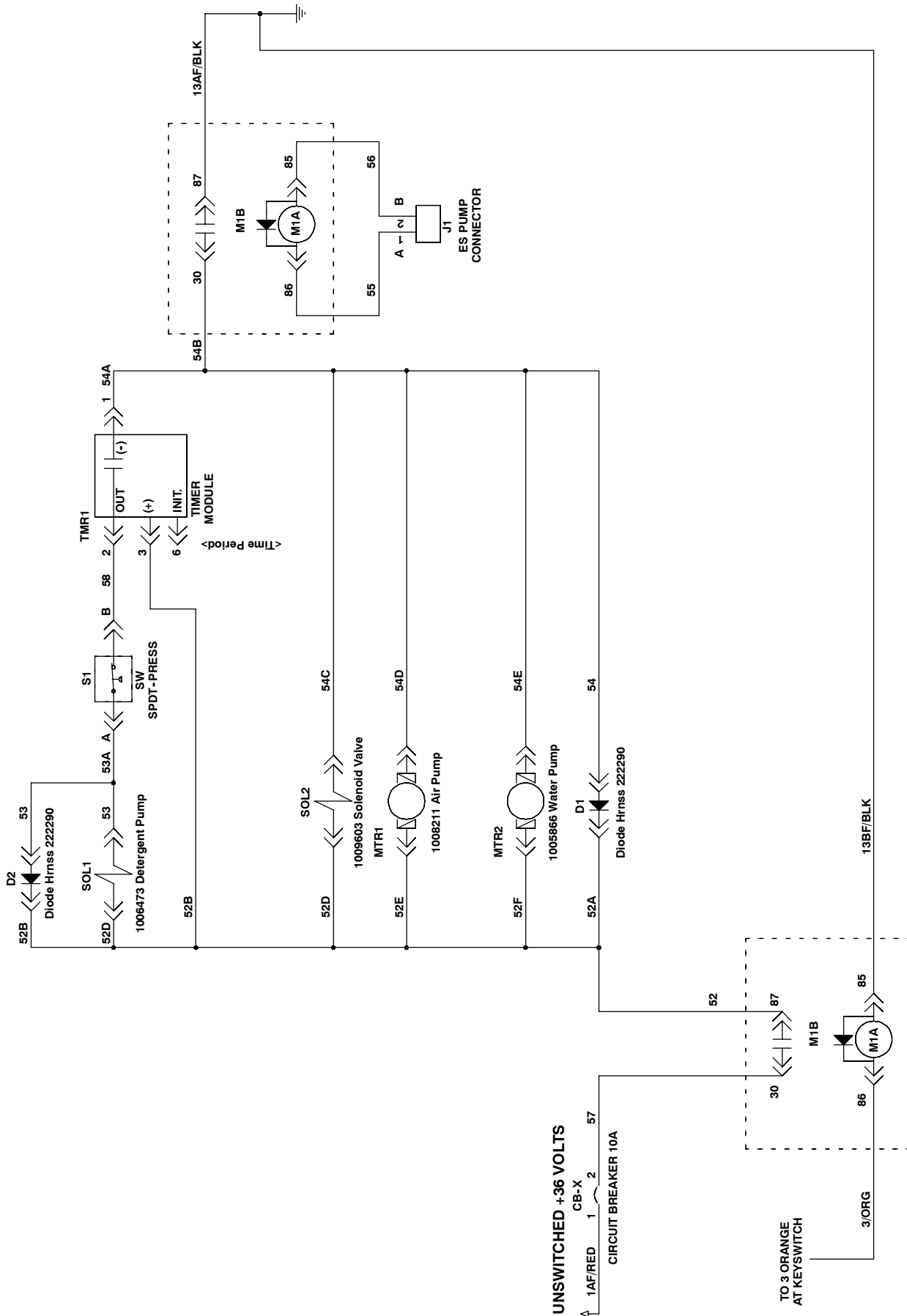
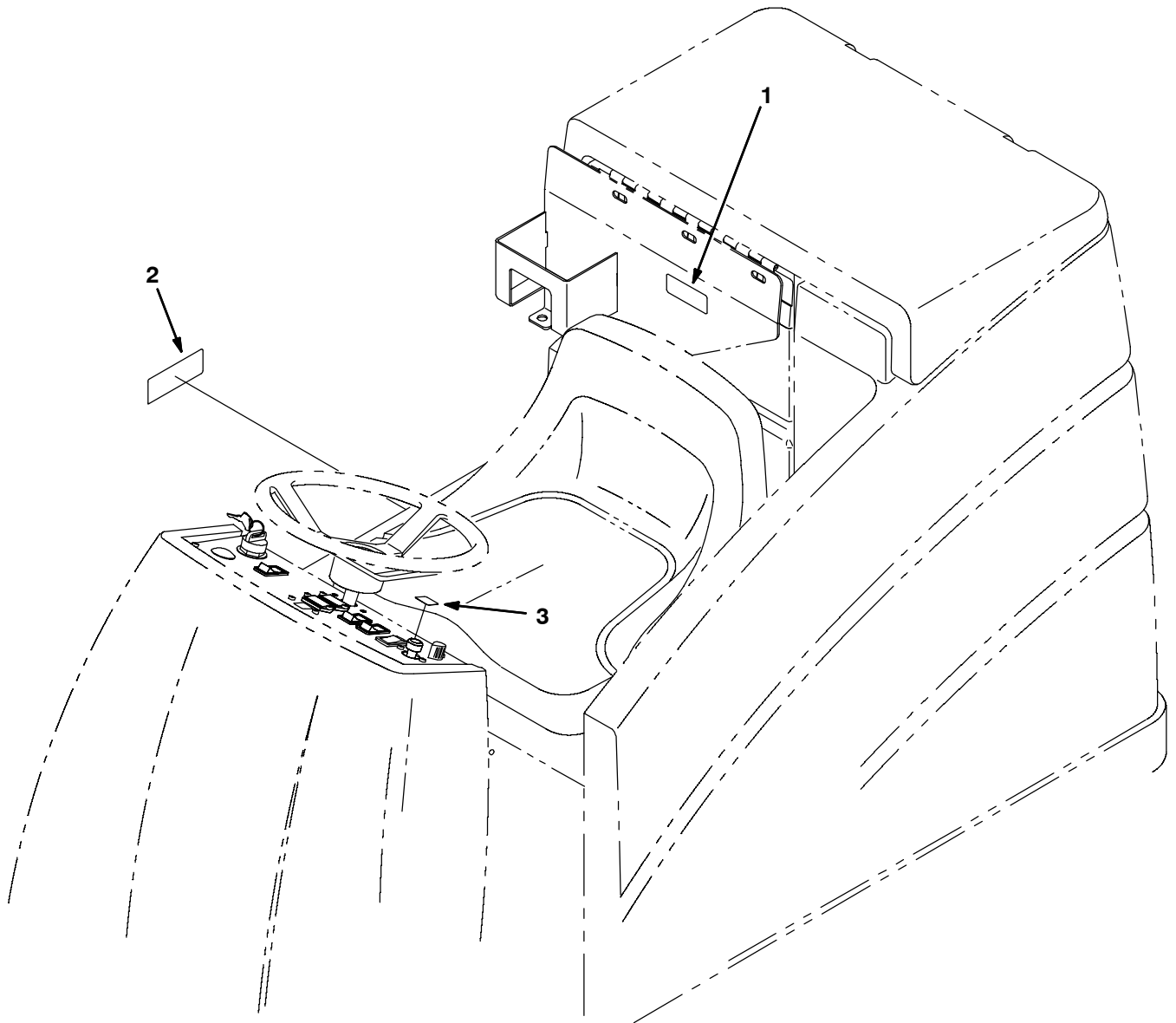

Fig. 11 - FaST Label Group



354185

Ref.	Nobles- Part No.	Description	Qty.
1	391451	Label, Attention Fast Users	1
2	1005416	Label, Fast	1
3	1014140	Label, Model, [Ezrider Hp Fast]	1

1 Serial number (10179742-)

OPTIONS

Fig. 12 - Heavy Duty Disk Scrub Head Drive Motor Group, 700 mm (28 in)
(0000000-10214060)

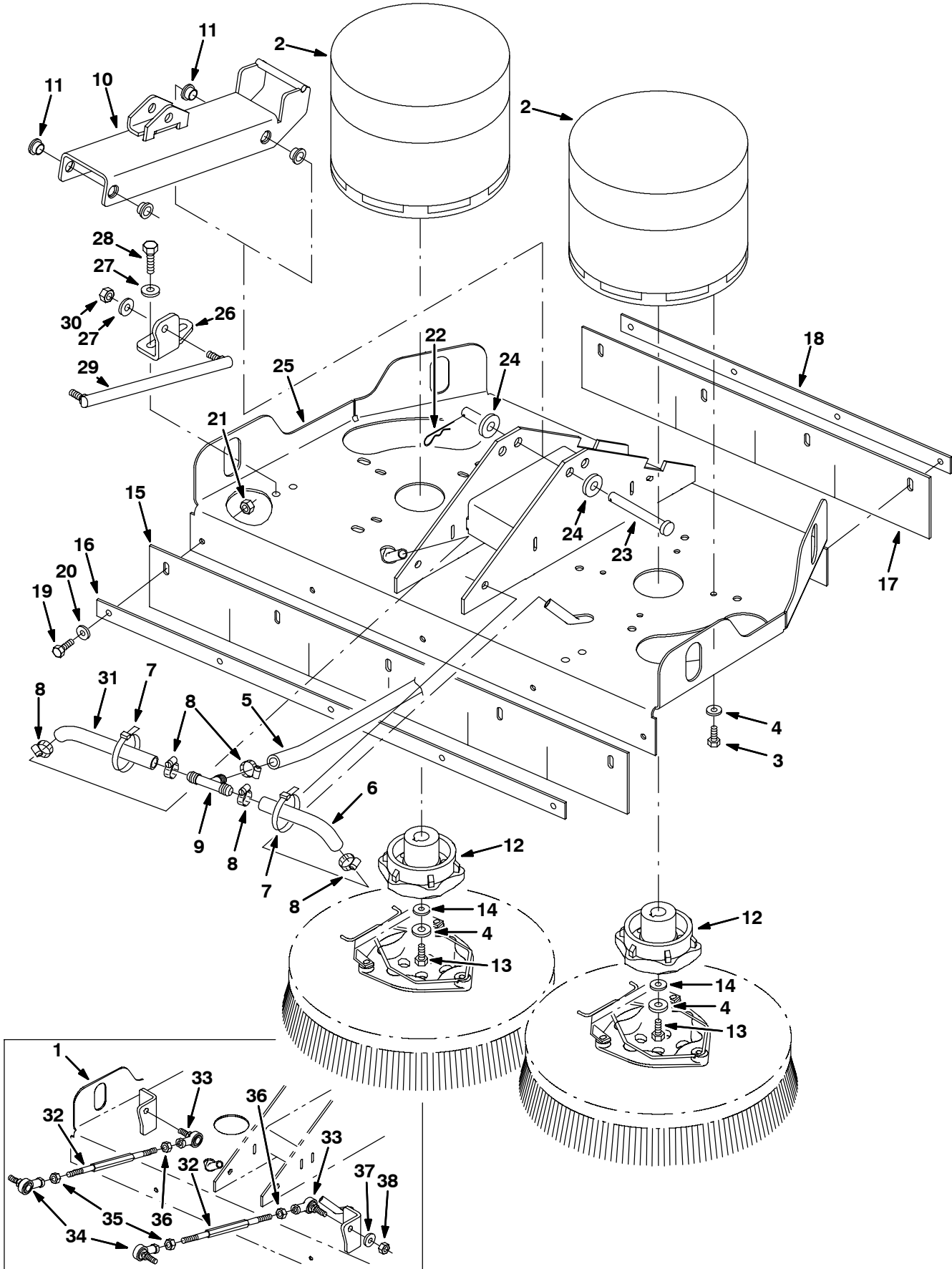

**Fig. 12 - Heavy Duty Disk Scrub Head Drive Motor Group, 700 mm (28 in)
(00000000-10214060)**

NOTE: Disk Scrub Head Kit, Nobles Part Number 392975, includes Fig. 12, and Fig. 14.

Ref.	Nobles- Part No.	Description	Qty.
1	393164	① Kit, Ci, Scrubhead, 700mm	1
2	223358	Motor, Ele, 36vdc, 0.80hp, 0320rpm (See Breakdowns)	2
3	02994	Screw, Hex, .38-16 X 0.75, Ss	8
4	01686	Washer, Flat, 0.44b 1.00 .08, Ss	10
5	390933	Hose, Pvc, Brd, 0.50id (376716)	25.00'
6	1011403	Hose, Afmkt Pvc, Brd 0.50id X 1 Ft (376716)	0.550'
7	44961	Tie, Cable, Nyl, 14.5L .30W 4.0 Max D	2
8	54333	Clamp, Hose, Wormdrive, 0.31-0.88d	5
9	63245-1	Fitting, Plstc, Tee, Bm08/Bm08/Bm08	1
10	392904	Channel Wldt, Tool, Lift, Disk [Ezrider]	1
11	15648	Bushing, Flng, 0.50b 0.59d 0.38l	4
12	377374	Hub, Drive, Brush, Disk, 0.75B 6T	2
13	02991	Screw, Hex, .31-18 X 0.75, Ss	2
14	41186	Washer, Belleville, .31	2
15	390633	Skirt, Front, Scb, Disk, 28 Inch	1
16	390635	Strip, Retainer, Skirt, Front, 28 Inch	1
17	390634	Skirt, Rear, Scb, Disk, 28 Inch	1
18	390636	Strip, Retainer, Skirt, Rear, 28 Inch	1
19	08716	Screw, Hex, M06 X 1.0 X 20, Ss	9
20	01684	Washer, Flat, .25 Ss	9
21	08712	Nut, Hex, Lock, M06 X 1.0, NI, Ss	9
22	44906	Pin, Hair Cotter, 0.69 D .092 Wir	1
23	222196	Pin, Clevis, 0.50 D X 4.00l	1
24	32486	Washer, Flt, .50 Sae	2
25	1015950	② Head Wldt, Scb, Disk, 700mm	1
26	1006123	② Bracket, Link, Head, Disk	2
27	01686	② Washer, Flat, 0.44b 1.00 .08, Ss	6
28	10959	② Screw, Hex, M10 X 1.5 X 20, SS, NL	4
29	392882	② Link, Balljoint, M10 X 1.5, 11.0L	2
30	08714	② Nut, Hex, Lock, M10 X 1.5, NL, SS	2
31	1011403	Hose, Afmkt Pvc, Brd 0.50id X 1 Ft (376716)	0.550'
32	390666	① Rod, Thrd, 2 End, .38-24 09.0l Lh/Rh	2
33	86780	① Rod-End, .38-24lh Fem 0.38-24stud	2
34	86781	① Rod-End, .38-24rh Fem 0.38-24stud	2
35	01686	① Washer, Flat, 0.44b 1.00 .08, Ss	4
36	20171	① Nut, Hex, Jam, .38-24	2
37	82889	① Nut, Hex, Jam, .38-24, Lh	2
38	50269	① Nut, Hex, Lock, .38-24, NI, Ss	4

① Serial number (00000000-10188432)

② Serial number (10188433-10214060)

**Fig. 13 - Heavy Duty Disk Scrub Head Drive Motor Group, 700 mm (28 in)
(10214061-)**

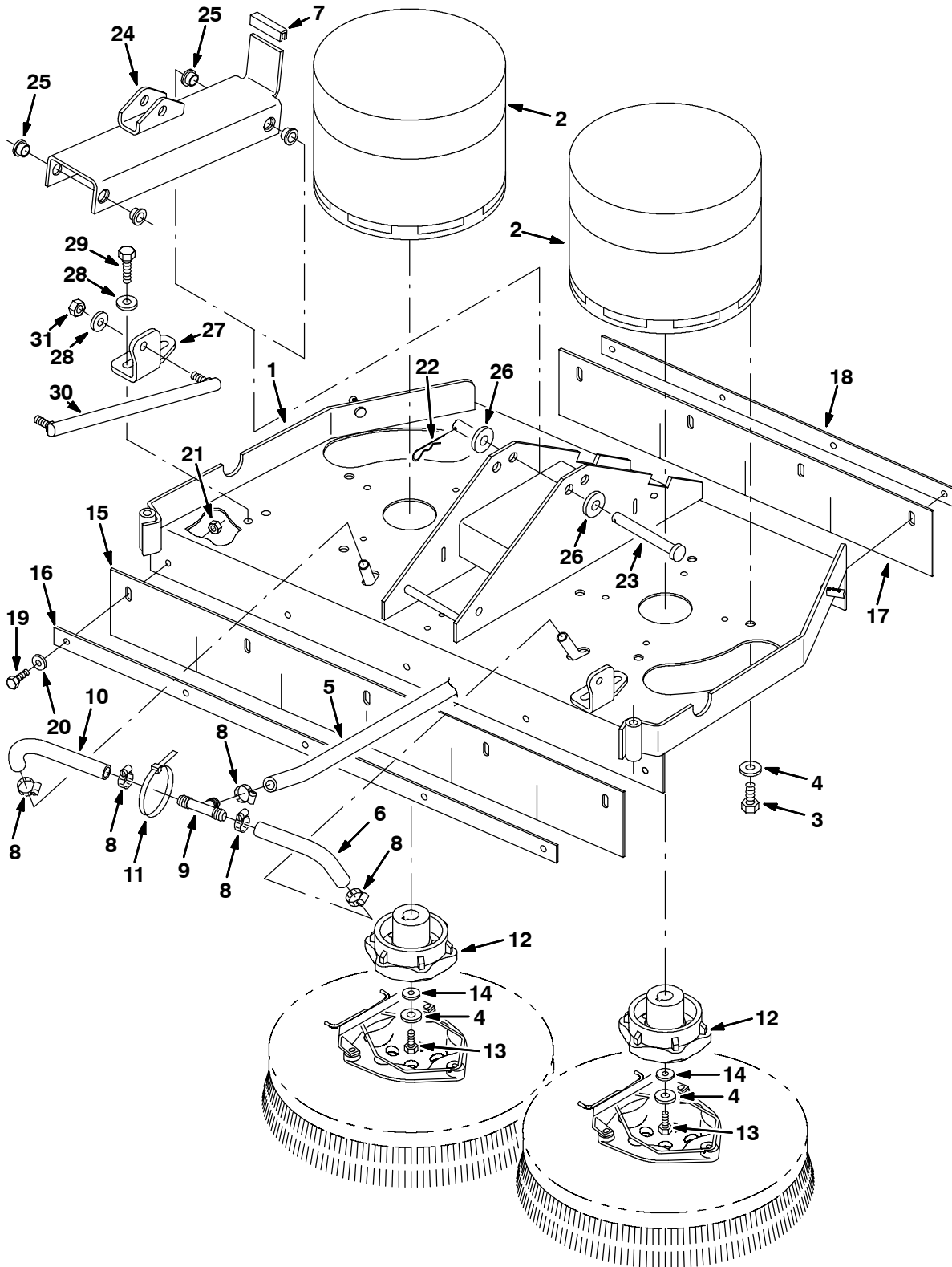
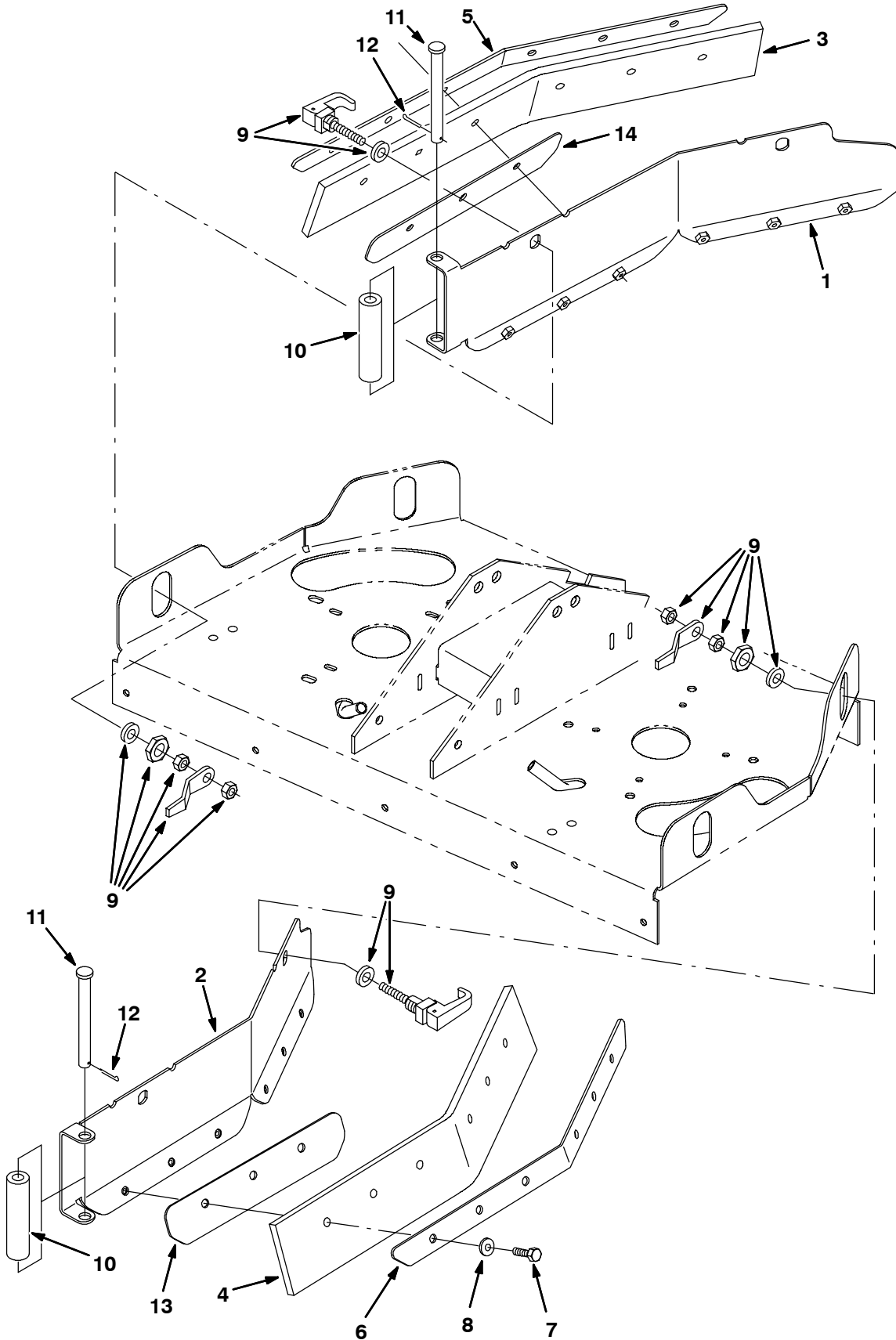

**Fig. 13 - Heavy Duty Disk Scrub Head Drive Motor Group, 700 mm (28 in)
(10214061-)**

NOTE: Disk Scrub Head Kit, Nobles Part Number 391031, includes Fig. 13, and Fig. 15.

Ref.	Nobles- Part No.	Description	Qty.
1	391370	Head Wldt, Scb, Disk, 28 Inch	1
2	223358	Motor, Ele, 36vdc, 0.80hp, 0320rpm (See Breakdowns)	2
3	02994	Screw, Hex, .38-16 X 0.75, Ss	8
4	01686	Washer, Flat, 0.44b 1.00 .08, Ss	10
5	390933	Hose, Pvc, Brd, 0.50id (376716)	25.00'
6	1011403	Hose, Afmkt Pvc, Brd 0.50id X 1 Ft (376716)	0.550'
7	223645	Molding, Trim, Rbr, .13 03.0	1
8	54333	Clamp, Hose, Wormdrive, 0.31-0.88d	5
9	63245-1	Fitting, Plstc, Tee, Bm08/Bm08/Bm08	1
10	1011403	Hose, Afmkt Pvc, Brd 0.50id X 1 Ft (376716)	0.550'
11	44961	Tie, Cable, Nyl, 14.5l .30w 4.0 Max D	1
12	377364	Hub, Drive, Brush, Disk, 0.75b 6t	2
13	02991	Screw, Hex, .31-18 X 0.75, Ss	2
14	41186	Washer, Belleville, .31	2
15	390633	Skirt, Front, Scb, Disk, 28 Inch	1
16	390635	Strip, Retainer, Skirt, Front, 28 Inch	1
17	390634	Skirt, Rear, Scb, Disk, 28 Inch	1
18	390636	Strip, Retainer, Skirt, Rear, 28 Inch	1
19	08716	Screw, Hex, M06 X 1.0 X 20, Ss	9
20	01684	Washer, Flt, .25 Ss	9
21	08712	Nut, Hex, Lock, M06 X 1.0, NI, Ss	9
22	02942	Pin, Hair Cotter, 0.62 D .120 Wir	1
23	222196	Pin, Clevis, 0.50 D X 4.00l	1
24	390741	Channel Wldt, Lift Tool	1
25	15648	Bushing, Flng, 0.50b 0.59d 0.38l	4
26	32486	Washer, Flt, .50 Sae	2
27	1006123	Bracket, Link, Head, Disk	2
28	01686	Washer, Flat, 0.44b 1.00 .08, Ss	6
29	10959	Screw, Hex, M10 X 1.5 X 20, SS, NL	4
30	392882	Link, Balljoint, M10 X 1.5, 11.0L	2
31	08714	Nut, Hex, Lock, M10 X 1.5, NL, SS	2

Fig. 14 - Heavy Duty Disk Scrub Head Squeegee Group, 700 mm (28 in)
(0000000-10214060)

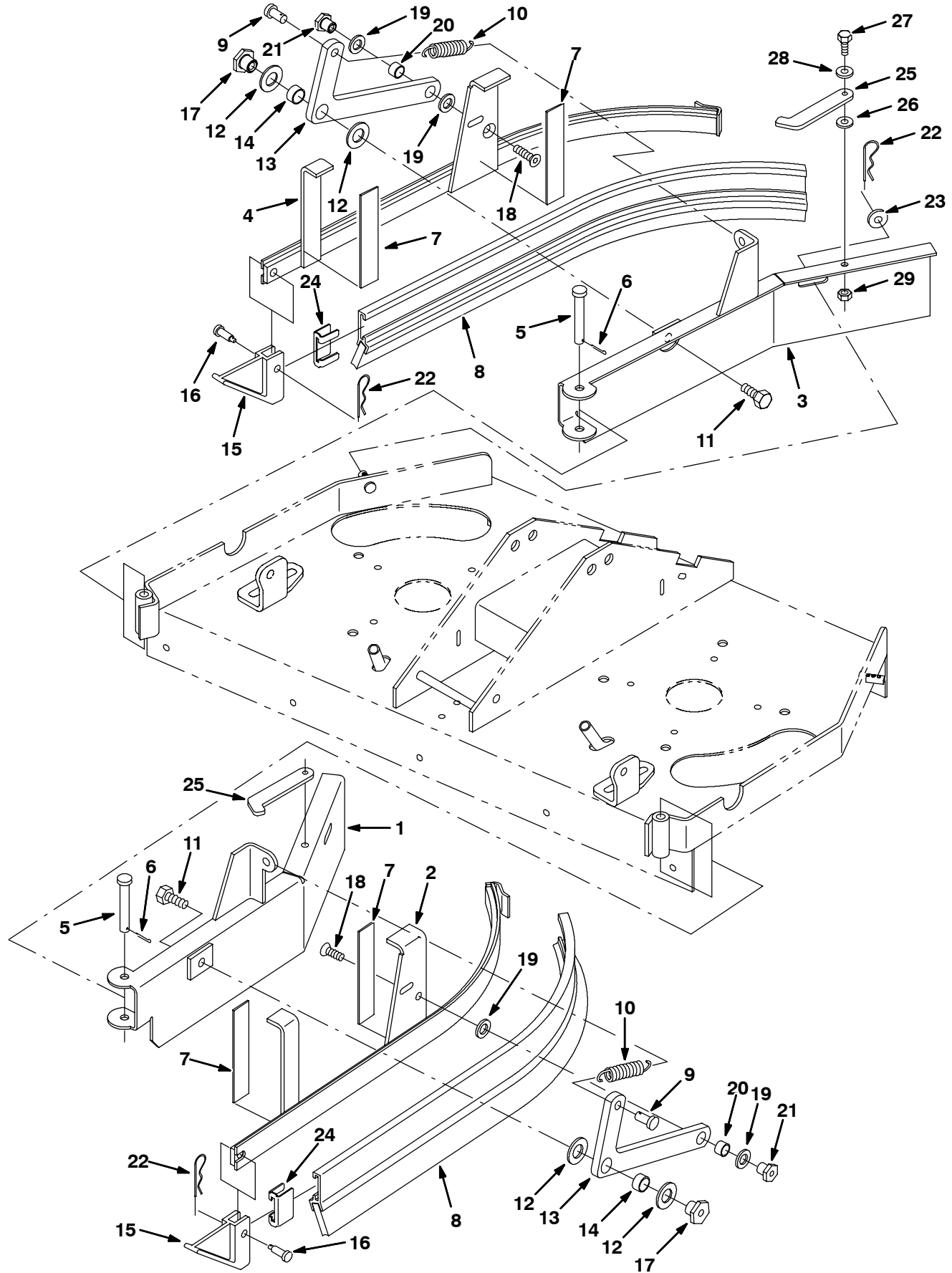

**Fig. 14 - Heavy Duty Disk Scrub Head Squeegee Group, 700 mm (28 in)
(00000000-10214060)**

NOTE: Disk Scrub Head Kit, Nobles Part Number 392975, includes Fig. 12, and Fig. 14.

Ref.	Nobles- Part No.	Description	Qty.
1	1001268	Angle, Rh	1
2	392841	Angle, Lh	1
3	1001290	Blade, Sqge, Rh	1
4	392842	Blade, Sqge, Lh	1
5	392823	Retainer, Rh	1
6	392840	Retainer, Lh	1
7	09007	Screw, Hex, M06 X 1.0 X 25, Ss	12
8	01684	Washer, Flat, .25 Ss	12
9	65695	Latch	4
10	222055	Roller, Linkage, Head	2
11	222197	Pin, Clevis, 0.50 D X 4.75l	2
12	08175	Pin, Cotter, .125 X 1.25	2
13	1008969	Plate, Backup, Sqge, Lh	1
14	1008981	Plate, Backup, Sqge, Rh	1

Fig. 15 - Heavy Duty Disk Scrub Head Squeegee Group, 700 mm (28 in)
(10214061-)

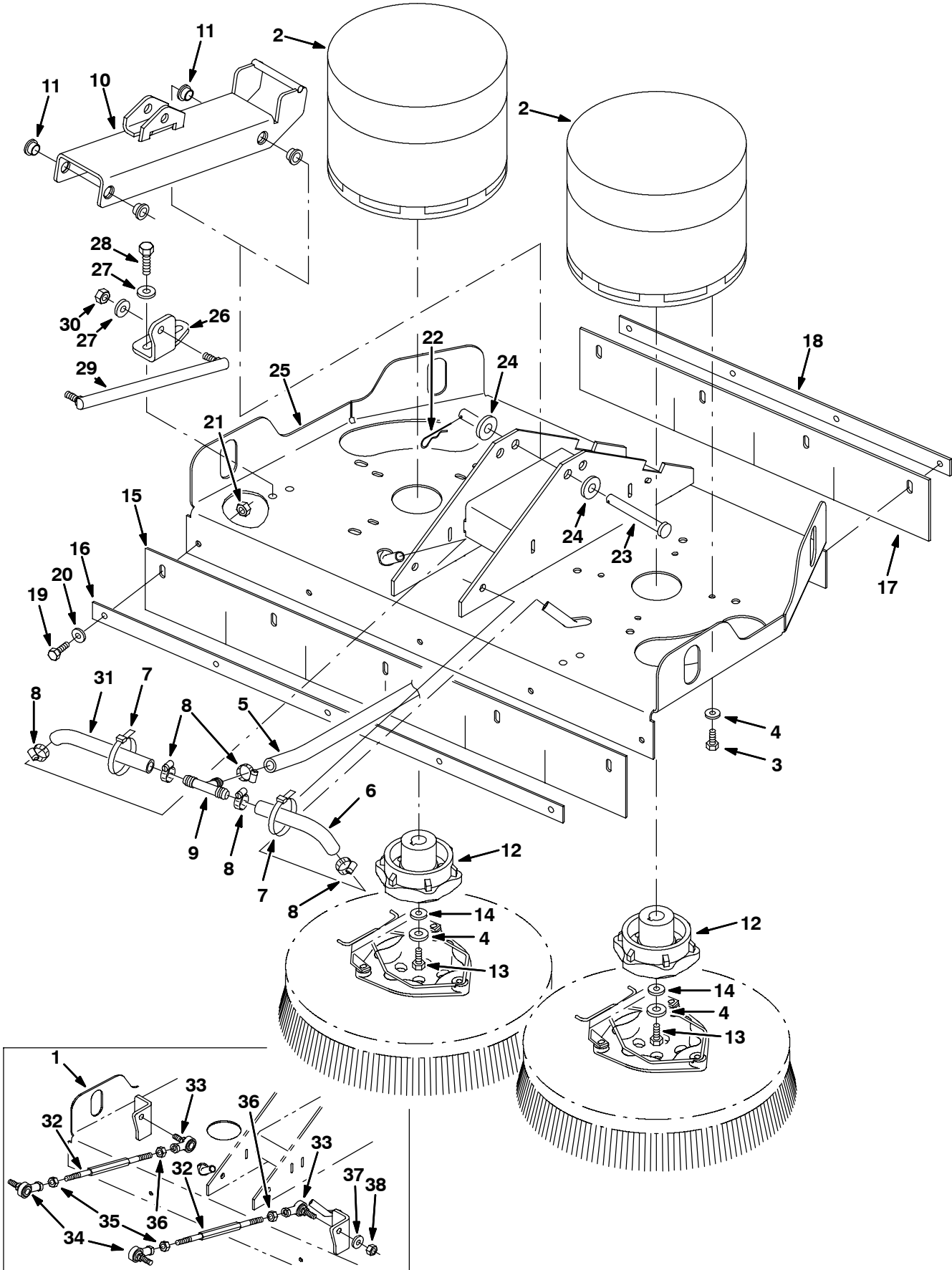

**Fig. 15 - Heavy Duty Disk Scrub Head Squeegee Group, 700 mm (28 in)
(10214061-)**

NOTE: Disk Scrub Head Kit, Nobles Part Number 391031, includes Fig. 13, and Fig. 15.

Ref.	Nobles- Part No.	Description	Qty.
1	390702	Door Wldt, Mtg, Lh, 28 Inch Disk	1
2	390707	Bladeholder Wldt, Sqge, Disk, Lh	1
3	390710	Door Wldt, Mtg, Rh, 28 Inch Disk	1
4	390720	Bladeholder Wldt, Sqge, Disk, Rh	1
5	391179	Pin, Clevis, 0.37 D X 2.62l	2
6	08182	Pin, Cotter, .125 X 1.00	2
7	390988	Tape, [Protective], .0080th, 1.0w, 5.0l	4
8	86859	Squeegee Assy, Side [Linatex]	2
9	39019	Pin, Clevis, 0.37 D X 0.75l	2
10	15047	Spring, Extn, 0.62od X 0.08wir, 3.0l	2
11	09291	Screw, Hex, M10 X 1.5 X 20, Ss	2
12	64425	Washer, Thrust, 0.61b 1.25d .06, Fgl	4
13	25709	Bellcrank, Lift, Sqge	2
14	71607	Bushing, Sleeve, 0.63b 0.72d 0.38l	2
15	86865	Guide, Side Sqge	2
16	69582	Pin, Clevis, 0.31 D X 1.00l	2
17	391345	Nut, T, M 10 X1.5 0.623od .516lg	2
18	79246	Screw, Flat, M08-1.25x 20, Ss	2
19	86860	Bearing, Thrust	4
20	64173	Bushing, Sleeve, 0.50b 0.59d 0.38l, Stl	2
21	391346	Nut, T, M8x1.25 X0.498od, 0.516lg	2
22	44906	Pin, Hair Cotter, 0.69 D .092 Wir	4
23	01686	Washer, Flat, 0.44b 1.00 .08, Ss	2
24	86759	Retainer, Sqge	2
25	390997	Lever, Lock, Side Sqge	2
26	16236	Washer, Flat, 0.26b 0.72d .06, Nyl	2
27	08716	Screw, Hex, M06 X 1.0 X 20, Ss	2
28	01684	Washer, Flat, .25 Ss	2
29	08712	Nut, Hex, Lock, M06 X 1.0, NI, Ss	2

**Fig. 16 - Disk Scrub Head Drive Motor Group, 800 mm (32 in)
(0000000-10214060)**



**Fig. 16 - Disk Scrub Head Drive Motor Group, 800 mm (32 in)
(00000000-10214060)**

NOTE: Disk Scrub Head Kit, Nobles Part Number 392995, includes Fig. 16, and Fig. 18.

Ref.	Nobles- Part No.	Description	Qty.
1	393165	① Kit, Ci, Scrubhead, 800mm	1
2	223358	Motor, Ele, 36vdc, 0.80hp, 0320rpm (See Breakdowns)	2
3	02994	Screw, Hex, .38-16 X 0.75, Ss	8
4	01686	Washer, Flat, 0.44b 1.00 .08, Ss	10
5	390933	Hose, Pvc, Brd, 0.50id (376716)	25.00'
6	1011403	Hose, Afmkt Pvc, Brd 0.50id X 1 Ft (376716)	0.550'
7	44961	Tie, Cable, Nyl, 14.5L .30W 4.0 Max D	2
8	54333	Clamp, Hose, Wormdrive, 0.31-0.88d	5
9	63245-1	Fitting, Plstc, Tee, Bm08/Bm08/Bm08	1
10	392904	Channel Wldt, Tool, Lift, Disk [Ezrider]	1
11	15648	Bushing, Flng, 0.50b 0.59d 0.38l	4
12	377374	Hub, Drive, Brush, Disk, 0.75B 6T	2
13	02991	Screw, Hex, .31-18 X 0.75, Ss	2
14	41186	Washer, Belleville, .31	2
15	390650	Skirt, Front, Scb, Disk, 32 Inch	1
16	390652	Strip, Retainer, Skirt, Front, 32 Inch	1
17	390651	Skirt, Rear, Scb, Disk, 32 Inch	1
18	390653	Strip, Retainer, Skirt, Rear, 32 Inch	1
19	08716	Screw, Hex, M06 X 1.0 X 20, Ss	9
20	01684	Washer, Flat, .25 Ss	9
21	08712	Nut, Hex, Lock, M06 X 1.0, NI, Ss	9
22	44906	Pin, Hair Cotter, 0.69 D .092 Wir	1
23	222196	Pin, Clevis, 0.50 D X 4.00l	1
24	32486	Washer, Flt, .50 Sae	2
25	1015951	② Head Wldt, Scb, Disk, 800mm	1
26	1006123	② Bracket, Link, Head, Disk	2
27	01686	② Washer, Flat, 0.44b 1.00 .08, Ss	6
28	10959	② Screw, Hex, M10 X 1.5 X 20, SS, NL	4
29	392882	② Link, Balljoint, M10 X 1.5, 11.0L	2
30	08714	② Nut, Hex, Lock, M10 X 1.5, NL, SS	2
31	1011403	Hose, Afmkt Pvc, Brd 0.50id X 1 Ft (376716)	0.550'
32	390666	① Rod, Thrd, 2 End, .38-24 09.0l Lh/Rh	2
33	86780	① Rod-End, .38-24lh Fem 0.38-24stud	2
34	86781	① Rod-End, .38-24rh Fem 0.38-24stud	2
35	01686	① Washer, Flat, 0.44b 1.00 .08, Ss	4
36	20171	① Nut, Hex, Jam, .38-24	2
37	82889	① Nut, Hex, Jam, .38-24, Lh	2
38	50269	① Nut, Hex, Lock, .38-24, NI, Ss	4

① Serial number (00000000-10188432)

② Serial number (10188433-10214060)

**Fig. 17 - Disk Scrub Head Drive Motor Group, 800 mm (32 in)
(10214061-)**

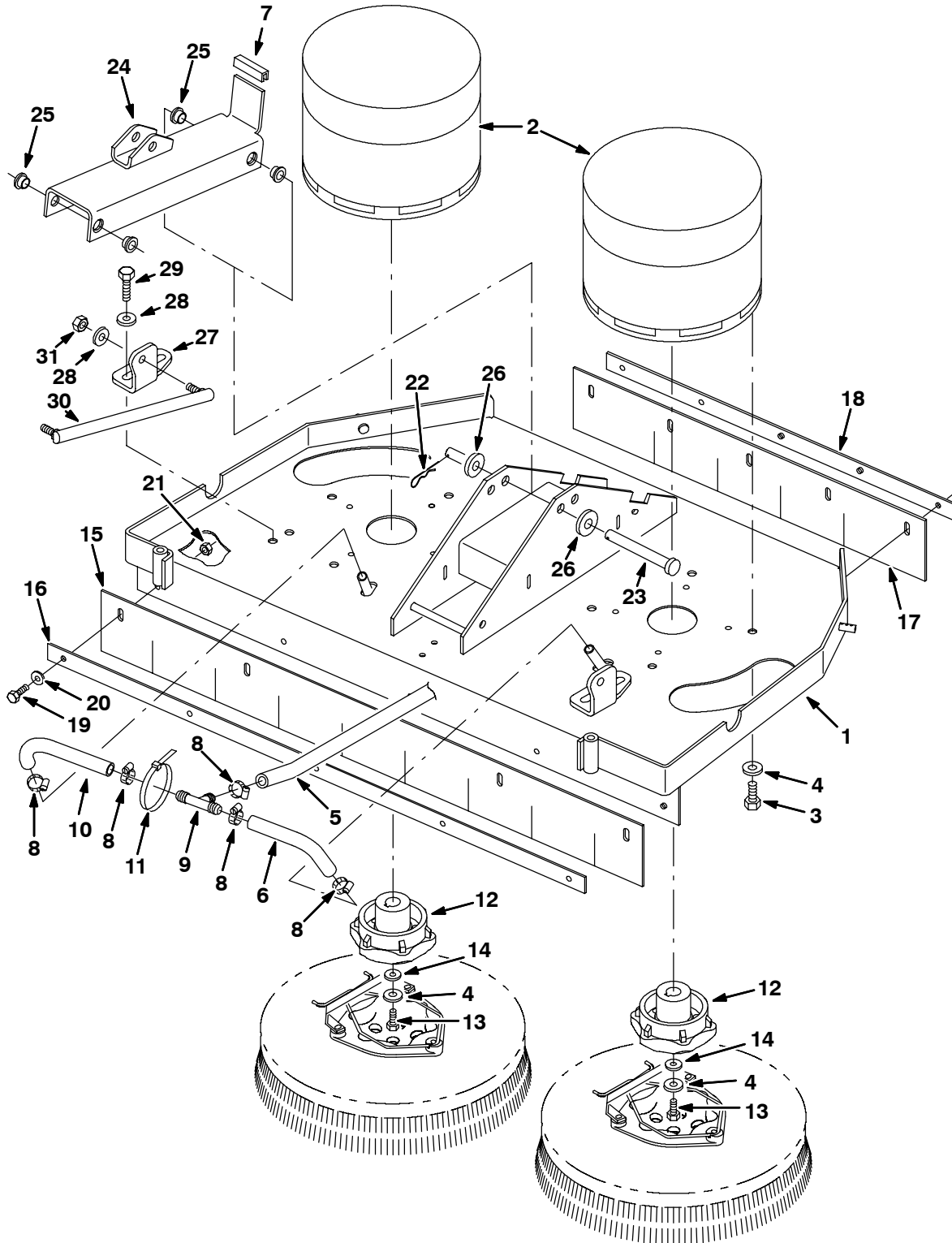
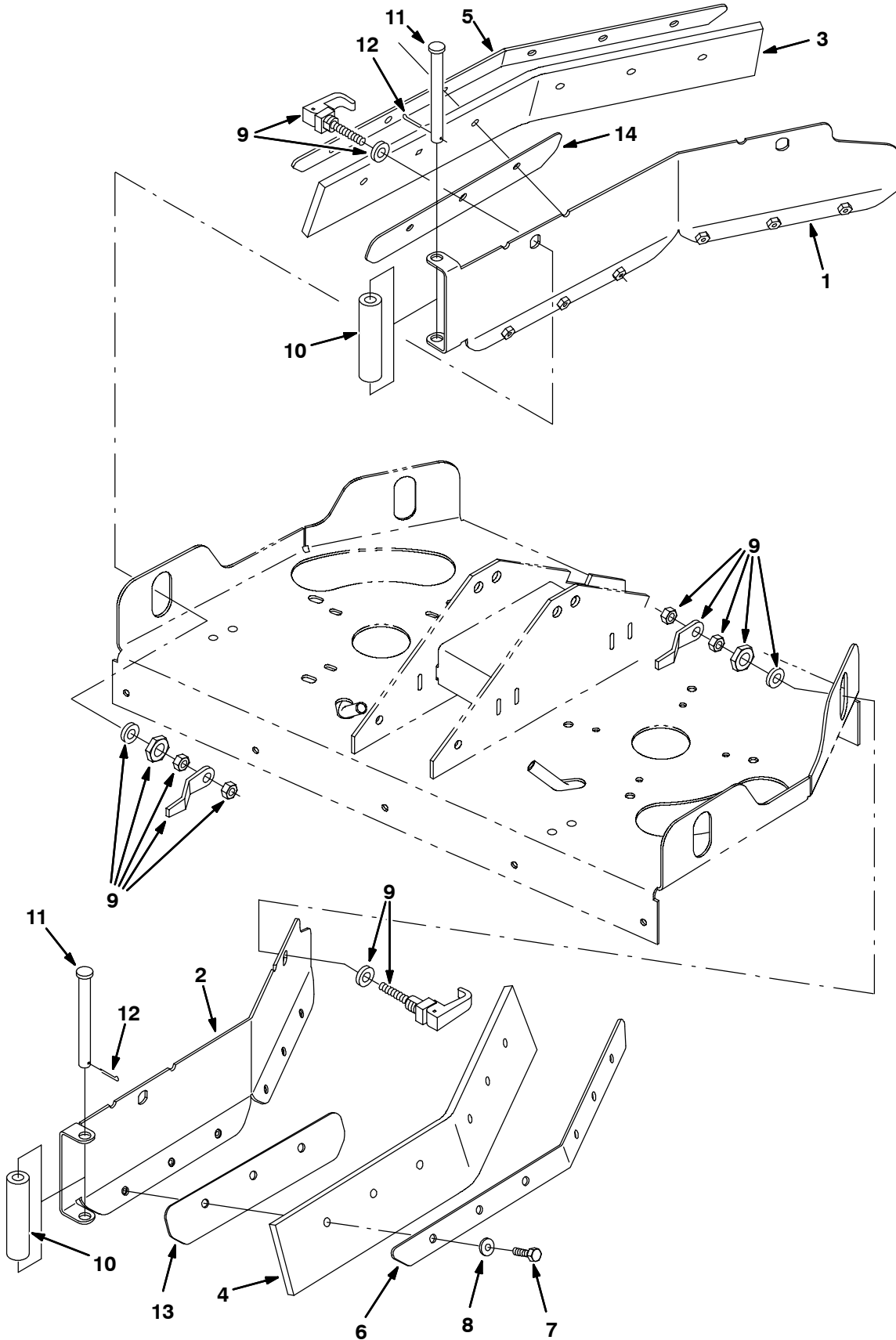

**Fig. 17 - Disk Scrub Head Drive Motor Group, 800 mm (32 in)
(10214061-)**

NOTE: Disk Scrub Head Kit, Nobles Part Number 391037, includes Fig. 17, and Fig. 19.

Ref.	Nobles- Part No.	Description	Qty.
1	390730	Head Wldt, Disk, 32 Inch Scb	1
2	223358	Motor, Ele, 36vdc, 0.80hp, 0320rpm (See Breakdowns)	2
3	02994	Screw, Hex, .38-16 X 0.75, Ss	8
4	01686	Washer, Flat, 0.44b 1.00 .08, Ss	8
5	390933	Hose, Pvc, Brd, 0.50id (376716)	25.00'
6	1011403	Hose, Afmkt Pvc, Brd 0.50id X 1 Ft (376716)	0.550'
7	1011403	Hose, Afmkt Pvc, Brd 0.50id X 1 Ft (376716)	0.550'
8	54333	Clamp, Hose, Wormdrive, 0.31-0.88d	5
9	63245-1	Fitting, Plstc, Tee, Bm08/Bm08/Bm08	1
10	222836	Shunt	1
11	44961	Tie, Cable, Nyl, 14.5l .30w 4.0 Max D	1
12	377364	Hub, Drive, Brush, Disk, 0.75b 6t	2
13	02991	Screw, Hex, .31-18 X 0.75, Ss	2
14	41186	Washer, Belleville, .31	2
15	390650	Skirt, Front, Scb, Disk, 32 Inch	1
16	390652	Strip, Retainer, Skirt, Front, 32 Inch	1
17	390651	Skirt, Rear, Scb, Disk, 32 Inch	1
18	390653	Strip, Retainer, Skirt, Rear, 32 Inch	1
19	08716	Screw, Hex, M06 X 1.0 X 20, Ss	9
20	01684	Washer, Flt, .25 Ss	9
21	08712	Nut, Hex, Lock, M06 X 1.0, NI, Ss	9
22	02942	Pin, Hair Cotter, 0.62 D .120 Wir	1
23	222196	Pin, Clevis, 0.50 D X 4.00l	1
24	390741	Channel Wldt, Lift Tool	1
25	15648	Bushing, Flng, 0.50b 0.59d 0.38l	4
26	32486	Washer, Flt, .50 Sae	2
27	1006123	Bracket, Link, Head, Disk	2
28	01686	Washer, Flat, 0.44b 1.00 .08, Ss	6
29	10959	Screw, Hex, M10 X 1.5 X 20, SS, NL	4
30	392882	Link, Balljoint, M10 X 1.5, 11.0L	2
31	08714	Nut, Hex, Lock, M10 X 1.5, NL, SS	2

Fig. 18 - Disk Scrub Head Squeegee Group, 800 mm (32 in)
(0000000-10214060)

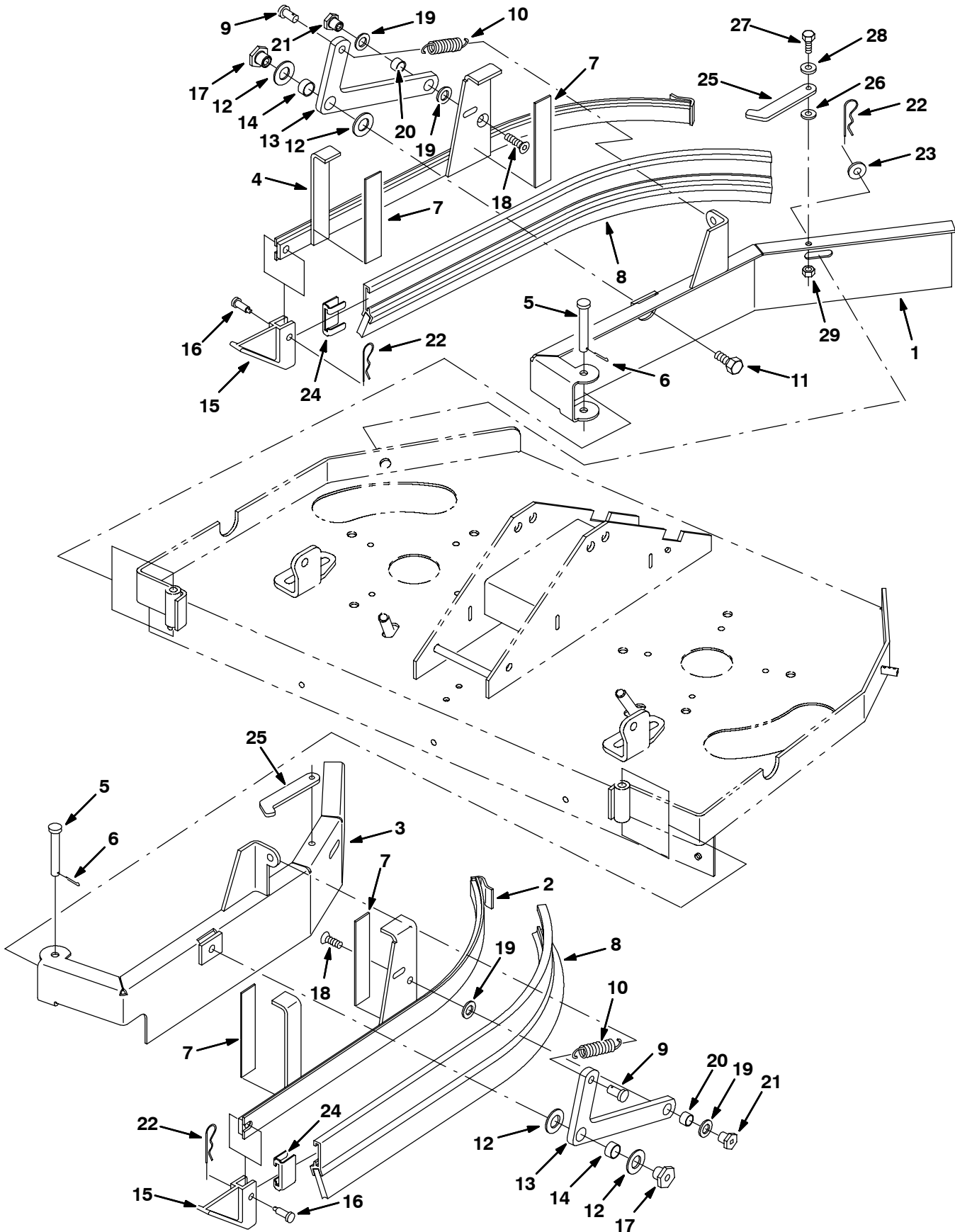

**Fig. 18 - Disk Scrub Head Squeegee Group, 800 mm (32 in)
(00000000-10214060)**

NOTE: Disk Scrub Head Kit, Nobles Part Number 392995, includes Fig. 16, and Fig. 18.

Ref.	Nobles- Part No.	Description	Qty.
1	1001268	Angle, Rh	1
2	392841	Angle, Lh	1
3	1001290	Blade, Sqge, Rh	1
4	392842	Blade, Sqge, Lh	1
5	392823	Retainer, Rh	1
6	392840	Retainer, Lh	1
7	09007	Screw, Hex, M06 X 1.0 X 25, Ss	12
8	01684	Washer, Flat, .25 Ss	12
9	65695	Latch	4
10	222055	Roller, Linkage, Head	2
11	222197	Pin, Clevis, 0.50 D X 4.75l	2
12	08175	Pin, Cotter, .125 X 1.25	2
13	1008969	Plate, Backup, Sqge, Lh	1
14	1008981	Plate, Backup, Sqge, Rh	1

**Fig. 19 - Disk Scrub Head Squeegee Group, 800 mm (32 in)
(10214061-)**



**Fig. 19 - Disk Scrub Head Squeegee Group, 800 mm (32 in)
(10214061-)**

NOTE: Disk Scrub Head Kit, Nobles Part Number 391037, includes Fig. 17, and Fig. 19.

Ref.	Nobles- Part No.	Description	Qty.
1	390734	Door Wldt, Sqge, Side, Rh, 800mm Disk	1
2	390707	Bladeholder Wldt, Sqge, Disk, Lh	1
3	390736	Door Wldt, Sqge, Side, Lh, 800mm Disk	1
4	390720	Bladeholder Wldt, Sqge, Disk, Rh	1
5	391179	Pin, Clevis, 0.37 D X 2.62l	2
6	08182	Pin, Cotter, .125 X 1.00	2
7	390988	Tape, [Protective], .0080th, 1.0w, 5.0l	4
8	86859	Squeegee Assy, Side [Linatex]	2
9	39019	Pin, Clevis, 0.37 D X 0.75l	2
10	15047	Spring, Extn, 0.62od X 0.08wir, 3.0l	2
11	09291	Screw, Hex, M10 X 1.5 X 20, Ss	2
12	64425	Washer, Thrust, 0.61b 1.25d .06, Fgl	4
13	25709	Bellcrank, Lift, Sqge	2
14	71607	Bushing, Sleeve, 0.63b 0.72d 0.38l	2
15	86865	Guide, Side Sqge	2
16	69582	Pin, Clevis, 0.31 D X 1.00l	2
17	391345	Nut, T, M 10 X1.5 0.623od .516lg	2
18	79246	Screw, Flat, M08-1.25x 20, Ss	2
19	86860	Bearing, Thrust	4
20	64173	Bushing, Sleeve, 0.50b 0.59d 0.38l, Stl	2
21	391346	Nut, T, M8x1.25 X0.498od, 0.516lg	2
22	44906	Pin, Hair Cotter, 0.69 D .092 Wir	4
23	01686	Washer, Flat, 0.44b 1.00 .08, Ss	2
24	86759	Retainer, Sqge	2
25	390997	Lever, Lock, Side Sqge	2
26	16236	Washer, Flat, 0.26b 0.72d .06, Nyl	2
27	08716	Screw, Hex, M06 X 1.0 X 20, Ss	2
28	01684	Washer, Flat, .25 Ss	2
29	08712	Nut, Hex, Lock, M06 X 1.0, NI, Ss	2

Fig. 20 - Cylindrical Scrub Head Drive Motor Group, 700 mm (28 in)

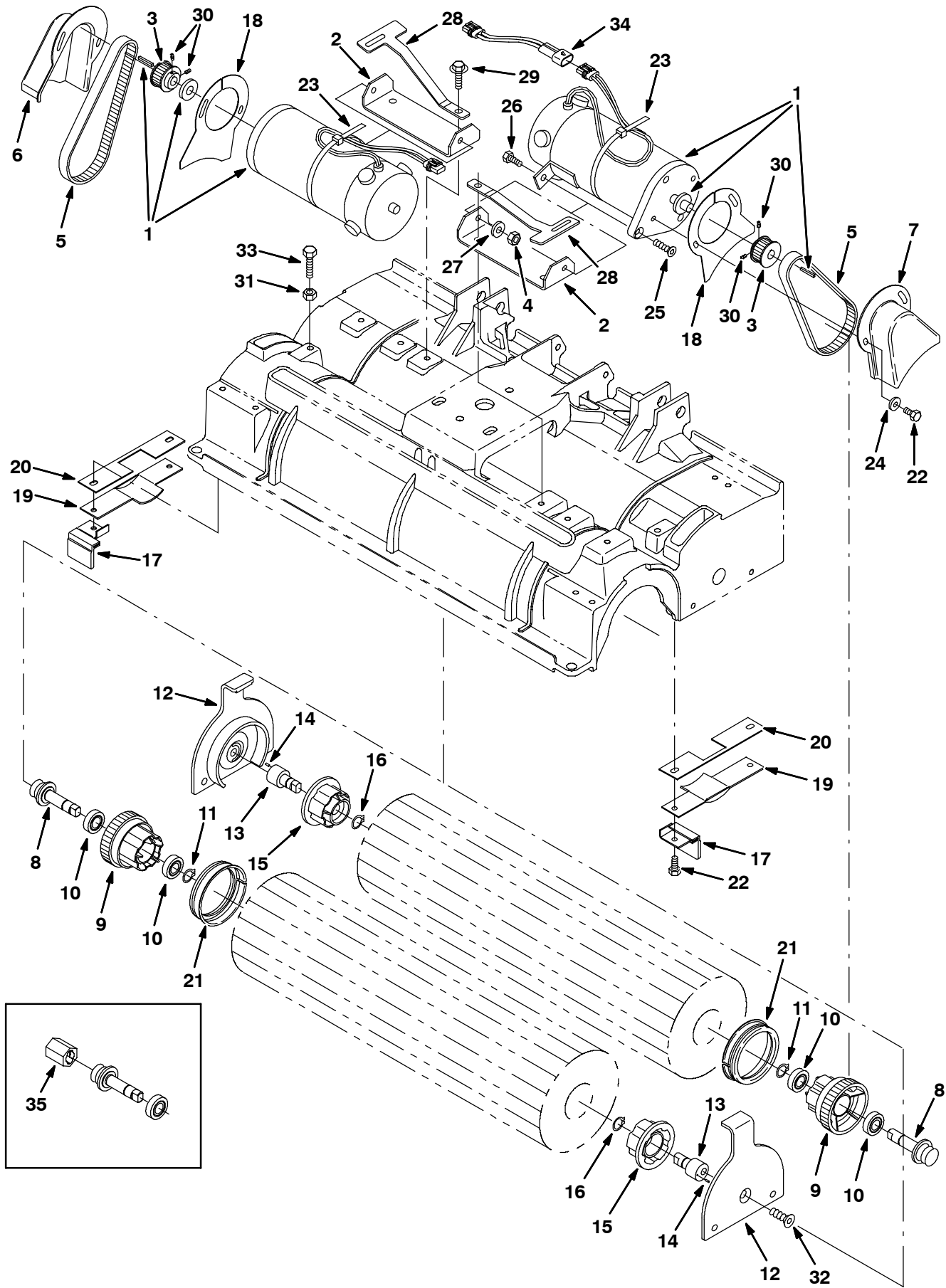

Fig. 20 - Cylindrical Scrub Head Drive Motor Group, 700 mm (28 in)

NOTE: Cylindrical Scrub Head Kit, Nobles Part Number 392992, includes Fig. 20, Fig. 21, and Fig. 22.

Ref.	Nobles- Part No.	Description	Qty.
1	374175	Motor Assy, Ele, 36Vdc, 0.75Hp (See Breakdowns)	2
2	223564	Bracket, Mtg, Motor	2
3	375195	Sprocket, Timing, 22tooth, 0.50b, [Gt/2]	2
4	08713	Nut, Hex, Lock, M08 X 1.25,NI, Ss	4
5	377505	Belt, Replmt, Brush Drive, F/222201	2
6	223560	Guard, Belt, Rh	1
7	223561	Guard, Belt, Lh	1
▽	222751	Plug Assy, Drive, Brush	2
▲	8 222176	Shaft, Drive Plug	1
▲	9 377333	Plug, Drive, Brush	1
▲	10 41360	Bearing, Ball, 0.59b 1.26d 0.35w	2
▲	11 01516	Ring, Retaining, Ext, 0.59d, Basic	1
	12 369460	Door, Brush	2
▽	222752	Plug Assy, Idler, Brush	2
▲	13 222177	Shaft, Idler Plug	1
▲	14 222184	Pin, Roll, .090 D 0.25l, .094/.097	1
▲	15 379202	Plug, Idler, Brush	1
▲	16 01516	Ring, Retaining, Ext, 0.59d, Basic	1
	17 223568	Deflector, Water	2
	18 223563	Guard, Belt, Drive, Scrbr Head, Lh	2
	19 223566	Bracket, Shield	2
	20 223569	Gasket, Shield	2
	21 222820	Seal, Ring	2
	22 15678	Screw, Hex, M06 X 1.0 X 16, Ss	8
	23 44961	Tie, Cable, Nyl, 14.5l .30w 4.0 Max D	2
	24 01684	Washer, Flt, .25 Ss	4
	25 79506	Screw, Flat, M08-1.25x 30, Ss	2
	26 09740	Screw, Hex, M08 X 1.25 X 20, Ss	2
	27 01685	Washer, Flt, .31 Ss	2
	28 222209	Spring, Flt, Door, Scrbr Head	2
	29 76099	Screw, Hex, M08 X 1.25 X 25, Fmg	4
	30 222818	Screw, Set, #08-32 X 0.25, NI	4
	31 08713	Nut, Hex, Lock, M08 X 1.25,NI, Ss	2
	32 390996	Screw, Flat, M10 X 1.5 X 20, Ss, NI	2
	33 09023	Screw, Hex, M08 X 1.25 X 35, Ss FI	2
	34 363468	Wire Assy, Jumper Reverse	1
	35 1010506	Tool, Removal, Shaft, F/222176	1

▽ ASSEMBLY

▲ INCLUDED IN ASSEMBLY

Fig. 21 - Cylindrical Scrub Head Frame Group, 700 mm (28 in)

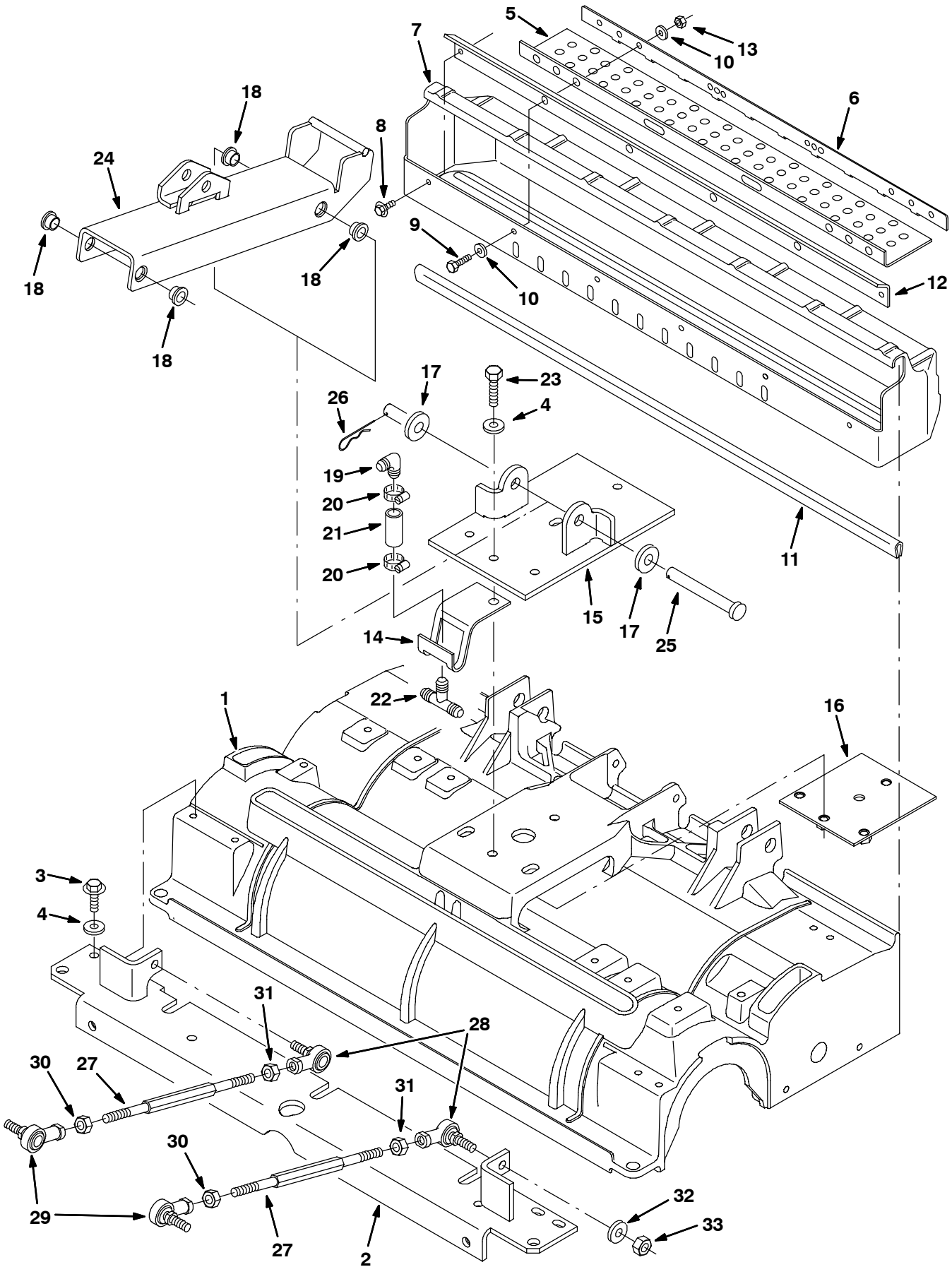

Fig. 21 - Cylindrical Scrub Head Frame Group, 700 mm (28 in)

NOTE: Cylindrical Scrub Head Kit, Nobles Part Number 392992, includes Fig. 20, Fig. 21, and Fig. 22.

Ref.	Nobles- Part No.	Description	Qty.
1	1022254	Housing, Cyl, Mach 700mm	1
2	390641	Angle Wldt, Tool, Lift, Cyl, 28 Inch	1
3	76099	Screw, Hex, M08 X 1.25 X 25, Fmg	4
4	01685	Washer, Flt, .31 Ss	8
▽	222824	Kit, Tray, Debris, 28 In	1
▲	5	222669 Skirt	1
▲	6	222670 Strip, Debris Tray	1
▲	7	222167 Tray	1
▲	8	74455 Screw, Hex, M06 X 1.0 X 12, Fmg	2
▲	9	09007 Screw, Hex, M06 X 1.0 X 25, Ss	4
▲	10	01684 Washer, Flt, .25 Ss	8
▲	11	374006 Channel, .18 0.50 0.03 29.0l	1
▲	12	222203 Lip, Debris Tray, 28in	1
▲	13	08712 Nut, Hex, Lock, M06 X 1.0, NI, Ss	4
▲	14	222523 Bracket, Guide, Hose	1
15	393016	Plate Wldt, Tool, Lift, Cyl	1
16	223412	Plate, Mounting, Tool Lift, Sc	1
17	32486	Washer, Flt, .50 Sae	2
18	15648	Bushing, Flng, 0.50b 0.59d 0.38l	4
19	63987-1	Fitting, Plstc, E90, Bm08/Bm08	1
20	54333	Clamp, Hose, Wormdrive, 0.31-0.88d	2
21	71793	Hose, Pvc, Clr, 0.50id 0.69od 01.50l	1
22	63245-1	Fitting, Plstc, Tee, Bm08/Bm08/Bm08	1
23	09011	Screw, Hex, M08 X 1.25 X 30, Ss	4
24	392933	Channel Wldt, Tool, Lift, Cyl [Ezrider]	1
25	59668	Pin, Clevis, 0.50 D X 4.50l	1
26	21120	Pin, Hair Cotter, 0.43 D .079 Wir	1
27	390666	Rod, Thrd, 2 End, .38-24 09.0l Lh/Rh	2
28	86780	Rod-End, .38-24lh Fem 0.38-24stud	2
29	86781	Rod-End, .38-24rh Fem 0.38-24stud	2
30	20171	Nut, Hex, Jam, .38-24	2
31	82889	Nut, Hex, Jam, .38-24, Lh	2
32	01686	Washer, Flat, 0.44b 1.00 .08, Ss	2
33	50269	Nut, Hex, Lock, .38-24, NI, Ss	2

▽ ASSEMBLY

▲ INCLUDED IN ASSEMBLY

Fig. 22 - Cylindrical Scrub Head Squeegee Group, 700 mm (28 in)

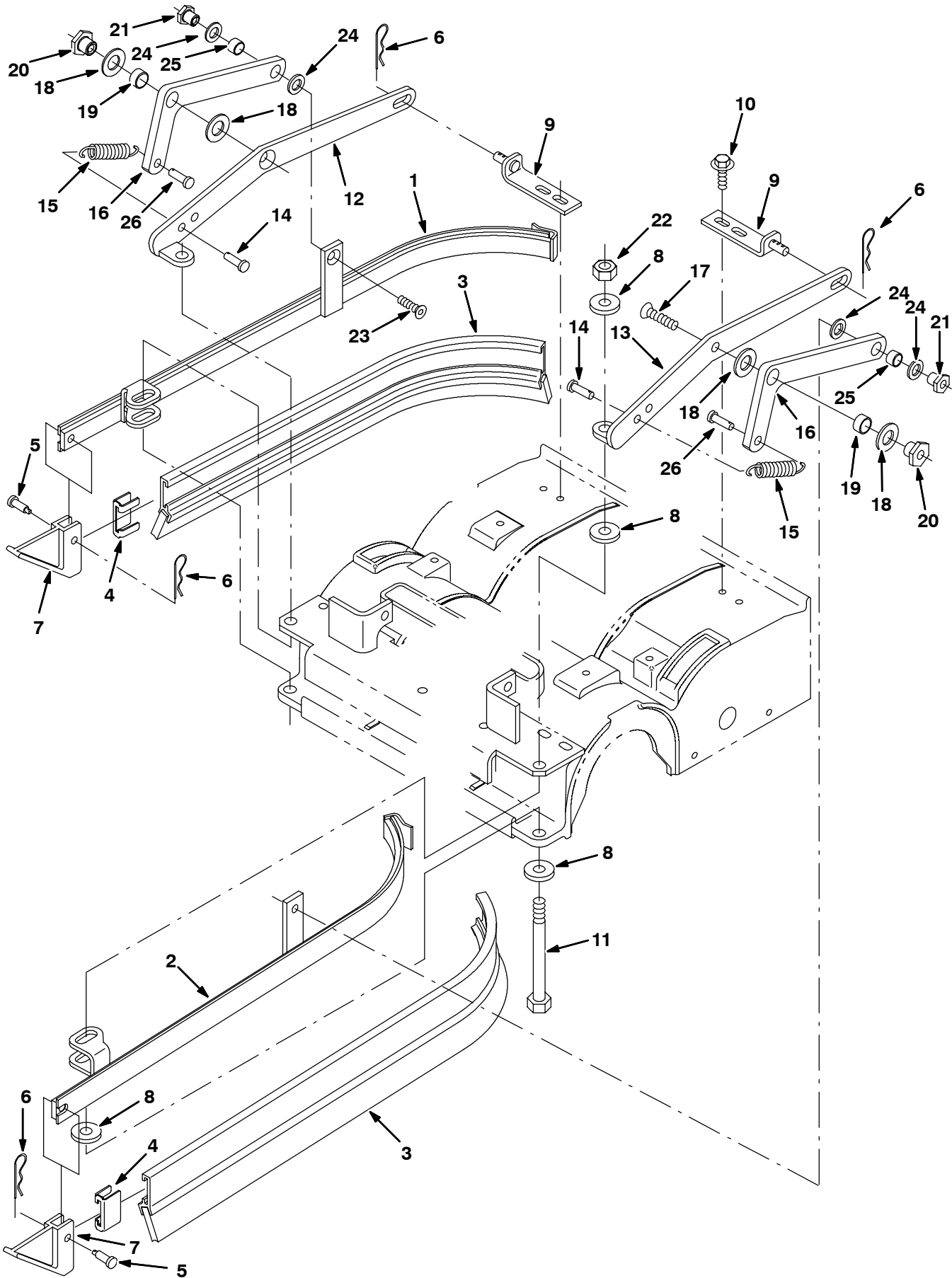

Fig. 22 - Cylindrical Scrub Head Squeegee Group, 700 mm (28 in)

NOTE: Cylindrical Scrub Head Kit, Nobles Part Number 392992, includes Fig. 20, Fig. 21, and Fig. 22.

Ref.	Nobles- Part No.	Description	Qty.
1	391327	Frame Wldt, Sqge, Side, Rh	1
2	391328	Frame Wldt, Sqge, Side, Lh	1
3	391334	Squeegee Assy, Side	2
4	86759	Retainer, Sqge	2
5	69582	Pin, Clevis, 0.31 D X 1.00l	2
6	44906	Pin, Hair Cotter, 0.69 D .092 Wir	4
7	86865	Guide, Side Sqge	2
8	33925	Washer, Flat, M12, 13x24x2.5ss	8
9	391176	Angle Wldt, Stop, Side Sqge, Cyl, Head	2
10	76099	Screw, Hex, M08 X 1.25 X 25, Fmg	4
11	19588	Screw, Hex, .50-13 X 5.00, 5	2
12	393017	Arm, Mtg, Link, Rh Sqge, Cyl Head	1
13	393018	Arm, Mtg, Link, Lh Sqge, Cyl Head	1
14	69582	Pin, Clevis, 0.31 D X 1.00l	2
15	15047	Spring, Extn, 0.62od X 0.08wir, 3.0l	2
16	25709	Bellcrank, Lift, Sqge	2
17	380587	Screw, Flat, M10 X 1.5 X 20, Ss	2
18	64425	Washer, Thrust, 0.61b 1.25d .06, Fgl	4
19	71607	Bushing, Sleeve, 0.63b 0.72d 0.38l	2
20	391345	Nut, T, M 10 X1.5 0.623od .516lg	2
21	391346	Nut, T, M8x1.25 X0.498od, 0.516lg	2
22	02931	Nut, Hex, Lock, .50-13, NI, Ss	2
23	79246	Screw, Flat, M08-1.25x 20, Ss	2
24	86860	Bearing, Thrust	4
25	64173	Bushing, Sleeve, 0.50b 0.59d 0.38l, Stl	2
26	39019	Pin, Clevis, 0.37 D X 0.75l	2

OPTIONS

Fig. 23 - Cylindrical Scrub Head Drive Motor Group, 800 mm (32 in)

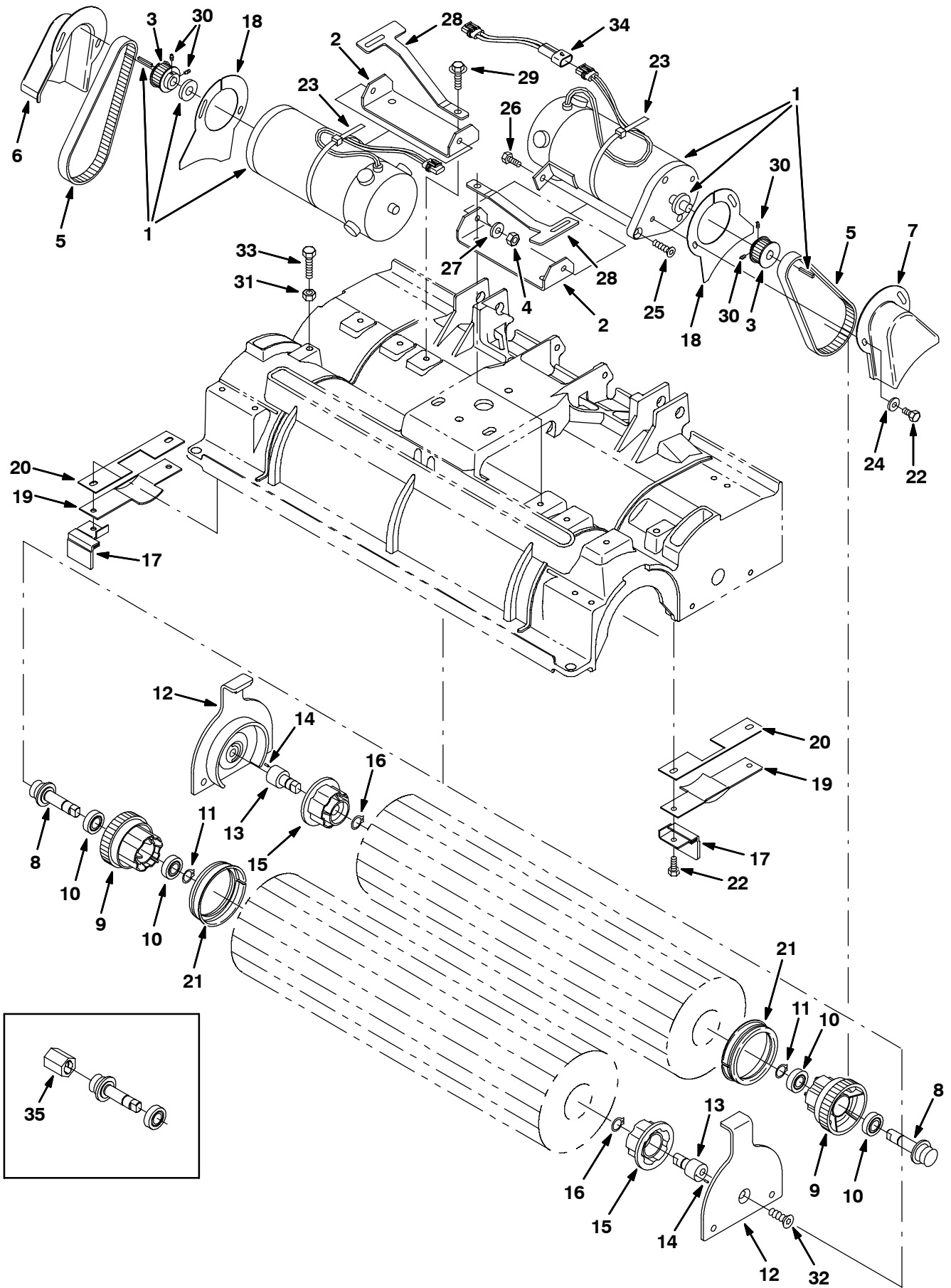

Fig. 23 - Cylindrical Scrub Head Drive Motor Group, 800 mm (32 in)

NOTE: Cylindrical Scrub Head Kit, Nobles Part Number 393003, includes Fig. 23, Fig. 24, and Fig. 25.

Ref.	Nobles- Part No.	Description	Qty.
1	374175	Motor Assy, Ele, 36Vdc, 0.75Hp (See Breakdowns)	2
2	223564	Bracket, Mtg, Motor	2
3	375195	Sprocket, Timing, 22tooth, 0.50b, [Gt/2]	2
4	08713	Nut, Hex, Lock, M08 X 1.25,NI, Ss	4
5	377505	Belt, Replmt, Brush Drive, F/222201	2
6	223560	Guard, Belt, Rh	1
7	223561	Guard, Belt, Lh	1
▽	222751	Plug Assy, Drive, Brush	2
▲	8 222176	Shaft, Drive Plug	1
▲	9 377333	Plug, Drive, Brush	1
▲	10 41360	Bearing, Ball, 0.59b 1.26d 0.35w	2
▲	11 01516	Ring, Retaining, Ext, 0.59d, Basic	1
	12 369460	Door, Brush	2
▽	222752	Plug Assy, Idler, Brush	2
▲	13 222177	Shaft, Idler Plug	1
▲	14 222184	Pin, Roll, .090 D 0.25l, .094/.097	1
▲	15 379202	Plug, Idler, Brush	1
▲	16 01516	Ring, Retaining, Ext, 0.59d, Basic	1
	17 223568	Deflector, Water	2
	18 223563	Guard, Belt, Drive, Scrbr Head, Lh	2
	19 223566	Bracket, Shield	2
	20 223569	Gasket, Shield	2
	21 222820	Seal, Ring	2
	22 15678	Screw, Hex, M06 X 1.0 X 16, Ss	8
	23 44961	Tie, Cable, Nyl, 14.5l .30w 4.0 Max D	2
	24 01684	Washer, Flt, .25 Ss	4
	25 79506	Screw, Flat, M08-1.25 X 30, Ss	2
	26 09740	Screw, Hex, M08 X 1.25 X 20, Ss	2
	27 01685	Washer, Flt, .31 Ss	2
	28 222209	Spring, Flt, Door, Scrbr Head	2
	29 76099	Screw, Hex, M08 X 1.25 X 25, Fmg	4
	30 222818	Screw, Set, #08-32 X 0.25, NI	4
	31 08713	Nut, Hex, Lock, M08 X 1.25,NI, Ss	2
	32 390996	Screw, Flat, M10 X 1.5 X 20, Ss, NI	2
	33 09023	Screw, Hex, M08 X 1.25 X 35, Ss FI	2
	34 363468	Wire Assy, Jumper Reverse	1
	35 1010506	Tool, Removal, Shaft, F/222176	1

▽ ASSEMBLY

▲ INCLUDED IN ASSEMBLY

Fig. 24 - Cylindrical Scrub Head Frame Group, 800 mm (32 in)

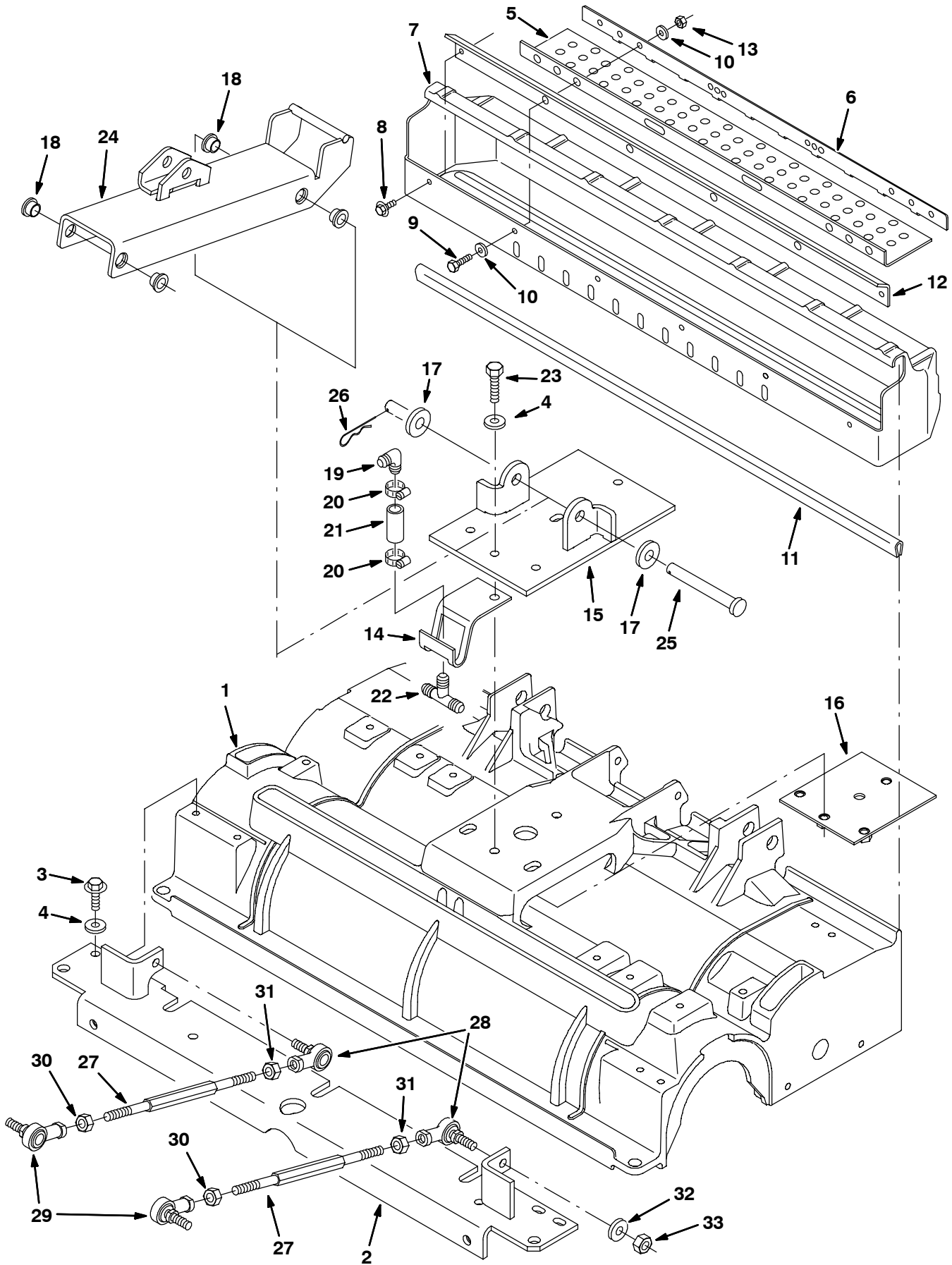

Fig. 24 - Cylindrical Scrub Head Frame Group, 800 mm (32 in)

NOTE: Cylindrical Scrub Head Kit, Nobles Part Number 393003, includes Fig. 23, Fig. 24, and Fig. 25.

Ref.	Nobles- Part No.	Description	Qty.
1	1022253	Housing, Cyl, Mach 800mm	1
2	390667	Angle Wldt, Tool, Lift, Cyl, 32 Inch	1
3	76099	Screw, Hex, M08 X 1.25 X 25, Fmg	4
4	01685	Washer, Flt, .31 Ss	3
▽	222825	Kit, Tray, Debris, 32 In	1
▲	5 222669	Skirt	1
▲	6 222670	Strip, Debris Tray	1
▲	7 391330	Tray, Debris, 32 Inch	1
▲	8 74455	Screw, Hex, M06 X 1.0 X 12, Fmg	2
▲	9 09007	Screw, Hex, M06 X 1.0 X 25, Ss	4
▲	10 01684	Washer, Flt, .25 Ss	8
▲	11 374007	Channel, .18 0.50 0.03 33.0l	1
▲	12 222204	Lip, Debris Tray, 32 In	1
▲	13 08712	Nut, Hex, Lock, M06 X 1.0, NI, Ss	4
▲	14 222523	Bracket, Guide, Hose	1
15	393016	Plate Wldt, Tool, Lift, Cyl	1
16	223412	Plate, Mounting, Tool Lift, Sc	1
17	32486	Washer, Flt, .50 Sae	2
18	15648	Bushing, Flng, 0.50b 0.59d 0.38l	4
19	63987-1	Fitting, Plstc, E90, Bm08/Bm08	1
20	54333	Clamp, Hose, Wormdrive, 0.31-0.88d	2
21	71793	Hose, Pvc, Clr, 0.50id 0.69od 01.50l	1
22	63245-1	Fitting, Plstc, Tee, Bm08/Bm08/Bm08	1
23	09011	Screw, Hex, M08 X 1.25 X 30, Ss	4
24	392933	Channel Wldt, Tool, Lift, Cyl [Ezrider]	1
25	59668	Pin, Clevis, 0.50 D X 4.50l	1
26	21120	Pin, Hair Cotter, 0.43 D .079 Wir	1
27	390666	Rod, Thrd, 2 End, .38-24 09.0l Lh/Rh	2
28	86780	Rod-End, .38-24lh Fem 0.38-24stud	2
29	86781	Rod-End, .38-24rh Fem 0.38-24stud	2
30	20171	Nut, Hex, Jam, .38-24	2
31	82889	Nut, Hex, Jam, .38-24, Lh	2
32	01686	Washer, Flat, 0.44b 1.00 .08, Ss	2
33	50269	Nut, Hex, Lock, .38-24, NI, Ss	2

▽ ASSEMBLY

▲ INCLUDED IN ASSEMBLY

Fig. 25 - Cylindrical Scrub Head Squeegee Group, 800 mm (32 in)

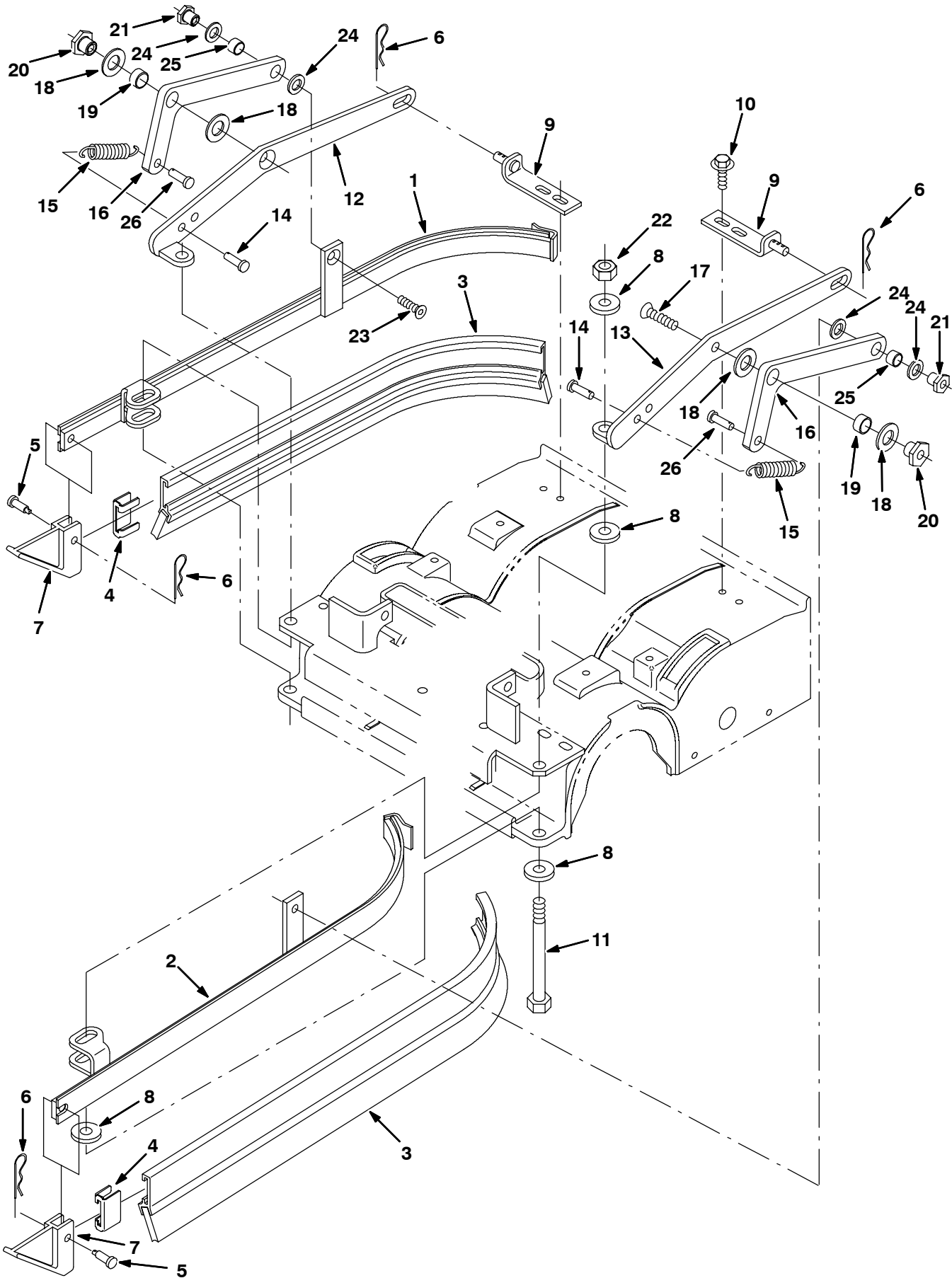

Fig. 25 - Cylindrical Scrub Head Squeegee Group, 800 mm (32 in)

NOTE: Cylindrical Scrub Head Kit, Nobles Part Number 393003, includes Fig. 23, Fig. 24, and Fig. 25.

Ref.	Nobles- Part No.	Description	Qty.
1	223413	Frame, Side Squeegee Rh	1
2	223304	Frame Wldt, Sqge, Lh, Cyl	1
3	86859	Blade Assy, Sqge, Side [Linatex]	2
4	86759	Retainer, Sqge	2
5	69582	Pin, Clevis, 0.31 D X 1.00l	2
6	44906	Pin, Hair Cotter, 0.69 D .092 Wir	4
7	86865	Guide, Side Sqge	2
8	33925	Washer, Flat, M12, 13x24x2.5ss	8
9	391176	Angle Wldt, Stop, Side Sqge, Cyl, Head	2
10	76099	Screw, Hex, M08 X 1.25 X 25, Fmg	4
11	19588	Screw, Hex, .50-13 X 5.00, 5	2
12	393017	Arm, Mtg, Link, Rh Sqge, Cyl Head	1
13	393018	Arm, Mtg, Link, Lh Sqge, Cyl Head	1
14	69582	Pin, Clevis, 0.31 D X 1.00l	2
15	15047	Spring, Extn, 0.62od X 0.08wir, 3.0l	2
16	25709	Bellcrank, Lift, Sqge	2
17	380587	Screw, Flat, M10 X 1.5 X 20, Ss	2
18	64425	Washer, Thrust, 0.61b 1.25d .06, Fgl	4
19	71607	Bushing, Sleeve, 0.63b 0.72d 0.38l	2
20	391345	Nut, T, M 10 X1.5 0.623od .516lg	2
21	391346	Nut, T, M8x1.25 X0.498od, 0.516lg	2
22	02931	Nut, Hex, Lock, .50-13, NI, Ss	2
23	79246	Screw, Flat, M08-1.25x 20, Ss	2
24	86860	Bearing, Thrust	4
25	64173	Bushing, Sleeve, 0.50b 0.59d 0.38l, Stl	2
26	39019	Pin, Clevis, 0.37 D X 0.75l	2

Fig. 26 - Rear Squeegee Group, 800 mm (32 in)

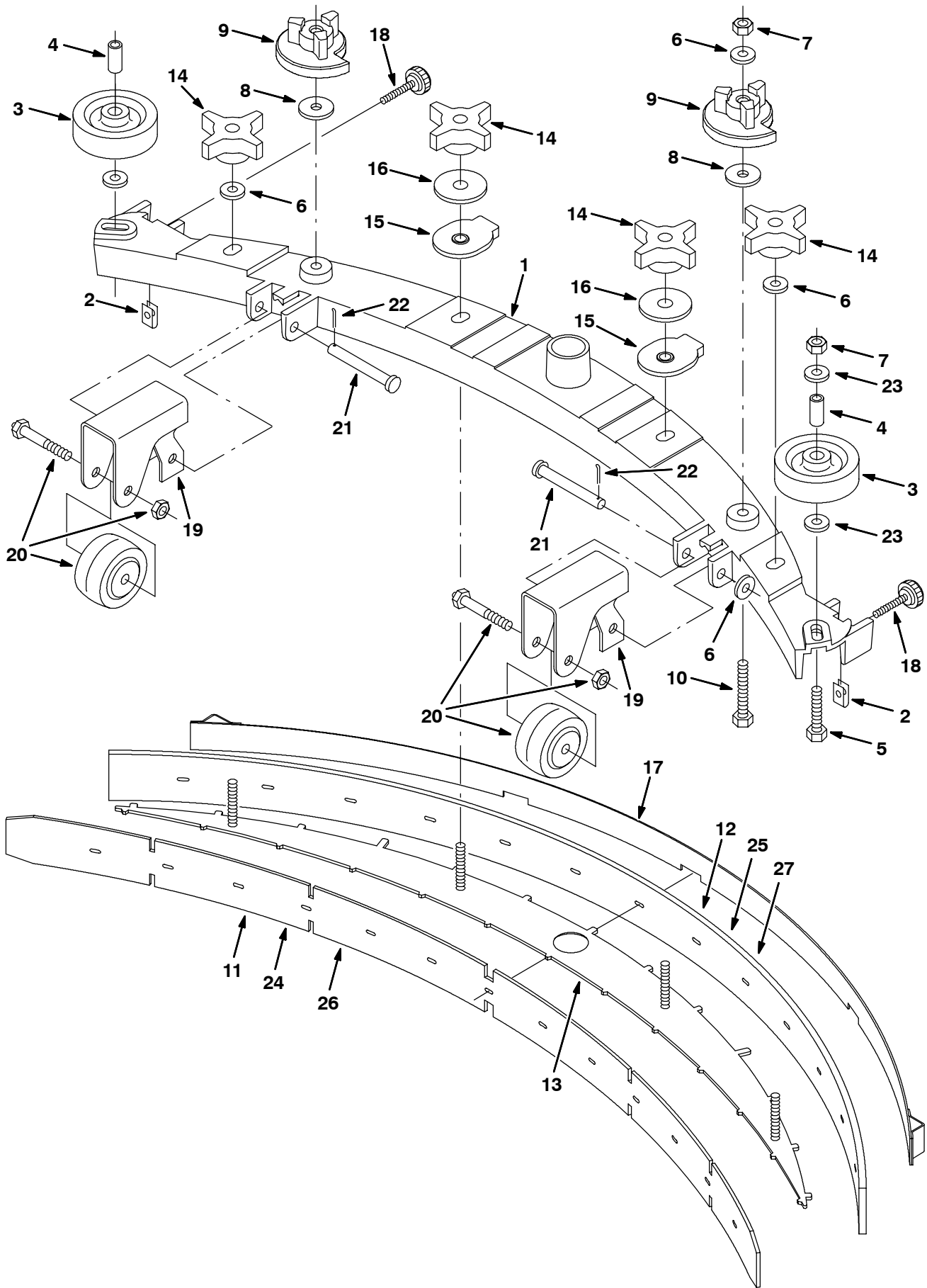

Fig. 26 - Rear Squeegee Group, 800 mm (32 in)

Ref.	Nobles-Part No.	Description	Qty.
▽	392981	Kit, Ci, Sqge Assy, Rear, 800mm[Ez/7080]	1
▲	1 390671	Frame, Casting, Sqge, 800mm	1
▲	2 82138	Nut, Speed, Clip, .25-20 [.025-.150]	2
▲	3 1010560	Wheel, Bmpr, 80d X 25w, Non-marking	2
▲	4 222460	Sleeve, P/M, 0.496d 0.318b 0.50l 430ss	2
▲	5 09011	Screw, Hex, M08 X 1.25 X 30, Ss	2
▲	6 01685	Washer, Flat, .31 Ss	6
▲	7 08713	Nut, Hex, Lock, M08 X 1.25, NI, Ss	4
▲	8 222268	Washer, 0.38b 1.25d .12, Neo	2
▲	9 222244	Cam, Adj, Sqge	2
▲	10 09767	Screw, Hex, M08 X 1.25 X 70, Ss	2
▲▽	391385	Kit, Sqge, Tile, 800mm [7100]	1
▲▲	11 390923	Blade, Sqge, Front, 800mm Linatex Red	1
▲▲	12 390934	Blade, Sqge, Rear, Gum Rbr, 800mm	1
▲	13 390920	Plate, Retainer, Blade, 800mm	1
▲	14 370100	Knob, Star, 2.8 4ear 1.1l .31-18 Plstc	4
▲	15 390982	Ring, Mtg, Sqge	2
▲	16 04414	Washer, 0.53b 1.88d .12, Stl, Pl	2
▲	17 390924	Retainer Wldt, Blade, Sqge, 1.2w 41.0l	1
▲	18 222794	Knob Assy, Rnd, 1.00d 0.50l .25-20 1.5l	2
▲	19 1005469	Bracket, Wheel, Sqge, Rear	2
▲	20 390773	Wheel Assy, Sqge	2
▲	21 23191	Pin, Clevis, 0.37 D X 3.00l	2
▲	22 39005	Pin, Cotter, .094 X 0.75	2
▲	23 140027	Washer, Flat, 0.35b 0.75d .04 Ss	4
▽	391383	Kit, Sqge, Oil-Rstn, 800mm [7100]	1
▲	24 391379	Blade, Sqge, Front, 800mm, Oil-Rstn	1
▲	25 391380	Blade, Sqge, Rear, 800mm, Oil-Rstn	1
▽	392989	Kit, Ci, Sqge, Linatex, 800mm[Ez/7080]	1
▲	26 390923	Blade, Sqge, Front, 800mm Linatex, Red	1
▲	27 390922	Blade, Sqge, Rear, 800mm Linatex, Red	1

▽ ASSEMBLY

▲ INCLUDED IN ASSEMBLY

Fig. 27 - Revolving Light Kit

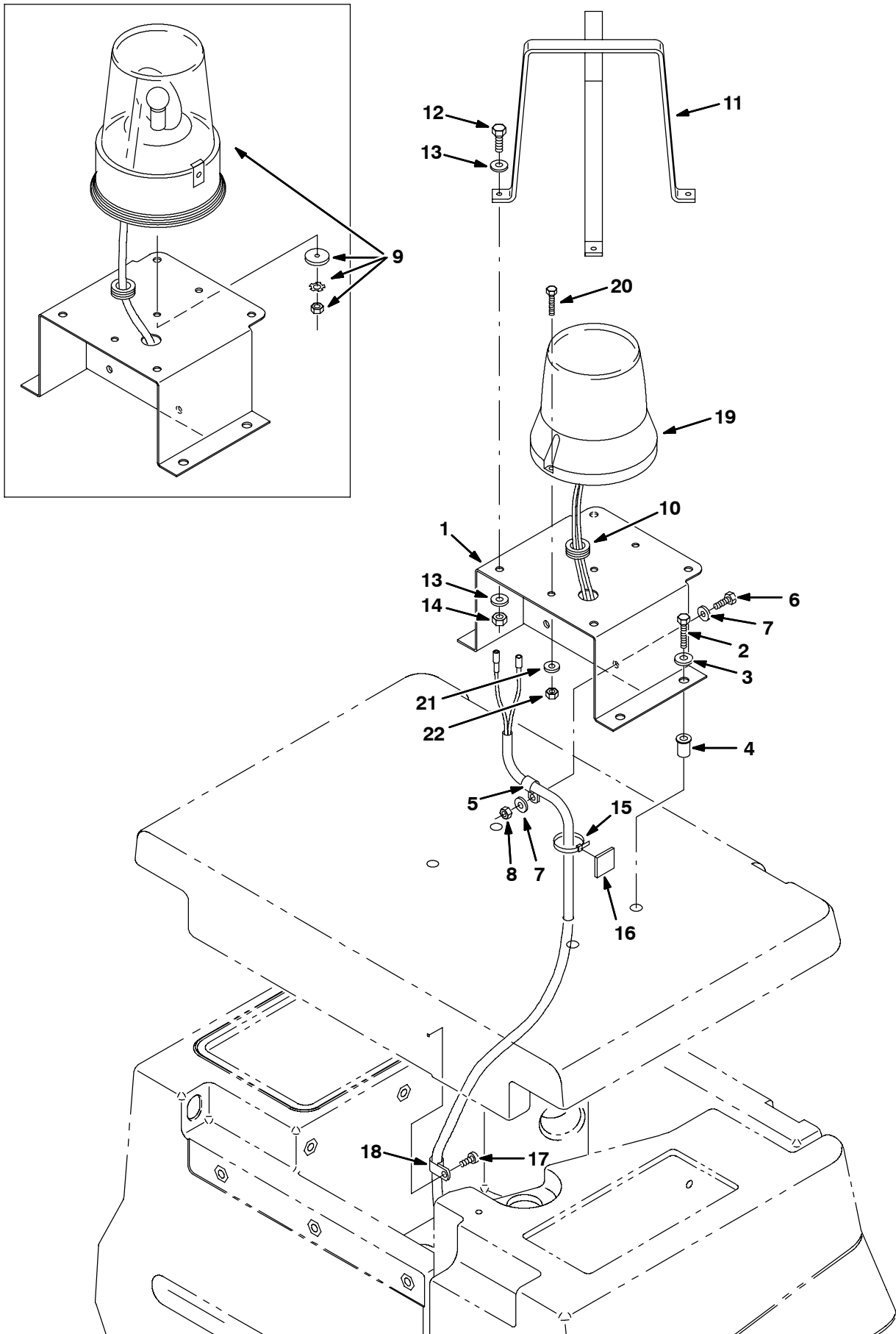

Fig. 27 - Revolving Light Kit

Ref.	Nobles- Part No.	Description	Qty.
▽	393048	Kit, Ci, Light, Revl [Ezhp/7080]	1
▲	1 392962	Bracket Wldt, Light	1
▲	2 16951	Screw, Hex, .25-20 X 1.25, Sems	4
▲	3 32491	Washer, Flt, .31 Std	4
▲	4 397644	Nut, Isolator, .25-20 Wall Thk .187-.343	4
▲	5 26395-1	Clamp, Cable, Stl, 0.56d X 0.38w, 1h	1
▲	6 06943	Screw, Hex, M06 X 1.0 X 20, 8.8	1
▲	7 32483	Washer, Flt, .25 Sae	2
▲	8 08708	Nut, Hex, Lock, M06 X 1.0, NI	1
▲▽	9 390916	① Lamp Assy, Revl	1
▲▲	45283	① Lamp, 40vdc, 0.9a	1
▲▲	44681-1	① Lens, Amber, Light, Revl	1
▲	10 10632-2	Grommet, Rbr, 0.62id, F/ 0.9h, .12matl	1
▲	11 45272	Guard Wldt, Light, Revl/Flsh	1
▲	12 06943	Screw, Hex, M06 X 1.0 X 20, 8.8	4
▲	13 32483	Washer, Flt, .25 Sae	8
▲	14 08708	Nut, Hex, Lock, M06 X 1.0, NI	4
▲	15 49263	Tie, Cable, Nyl, 11.4l .19w 3.0 Max D	2
▲	16 55248	Mount, Cable Tie	1
▲	17 360973	Screw, Pan, #12-16 X 0.50, F/ Plstc	1
▲	18 26395-2	Clamp, Cable, Stl, 0.38d X 0.38w, 1h	1
▲▽	19 1017248	② Light, Flsh, Amb, 12-48 Vdcl	1
▲▲	9000845	② Lamp, Bulb, Lamp, Flsh	1
▲▲	9000879	② Lens, Lamp, Amb, Strobe/Flasher	1
▲	20 09244	② Screw, Hex, M5 X 0.8 X 16, 8.8	2
▲	21 19066	② Washer, Flat, #10	2
▲	22 06549	② Nut, Hex, Lock, M5 X 0.8, NI	2
	44681	① Lens, Red, Light, Revl	1
	44681-2	① Lens, Blue, Light, Revl	1
	1027798	② Lens, Red, Option, F/Revl/Flsh Light	1
	1027800	② Lens, Blue, Option, F/Revl/Flsh Light	1

① Serial number (0000000-10221852)

② Serial number (10221853-)

▽ ASSEMBLY

▲ INCLUDED IN ASSEMBLY

Fig. 28 - Flashing Light Kit

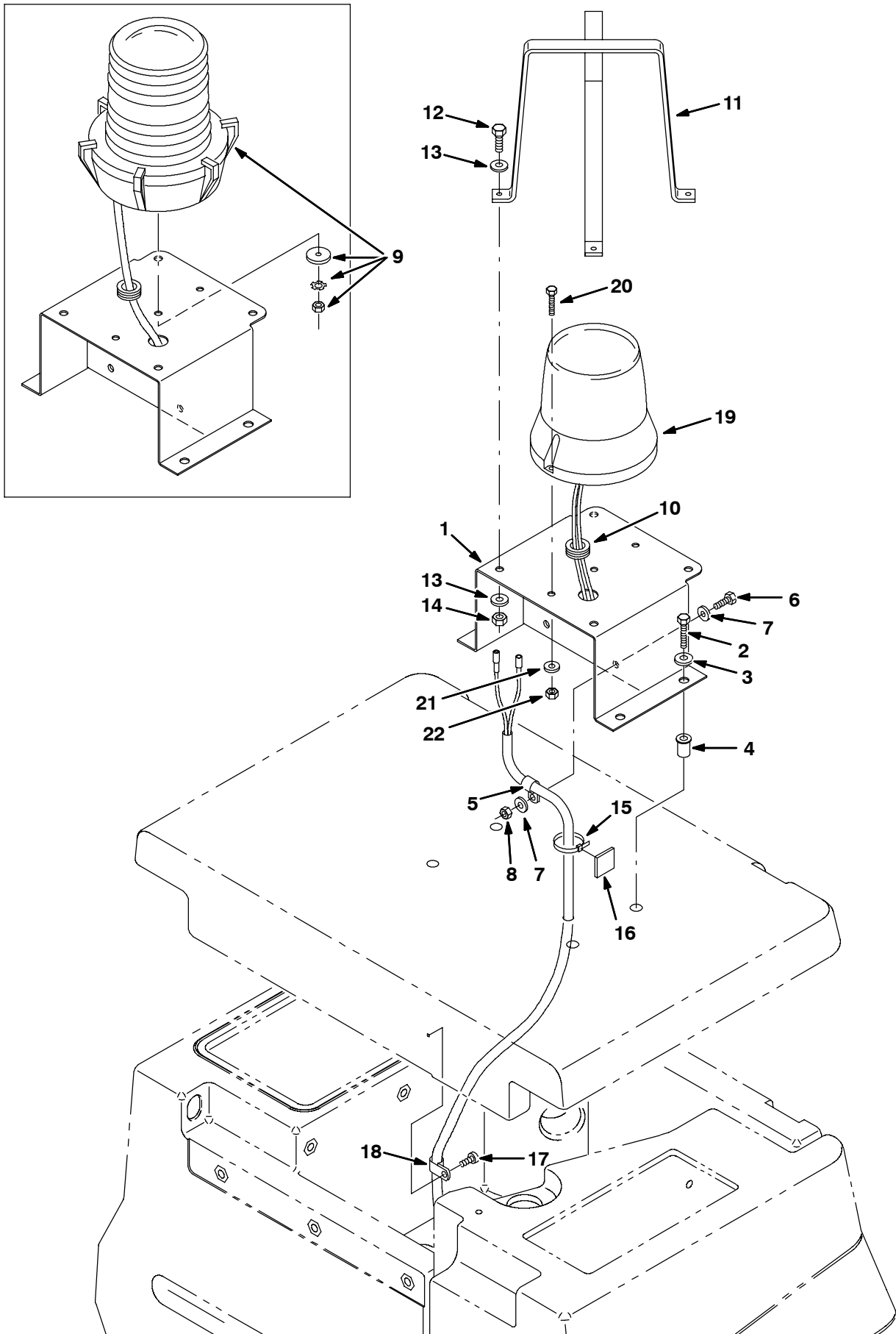

Fig. 28 - Flashing Light Kit

Ref.	Nobles- Part No.	Description	Qty.
▽	393049	Kit, Ci, Light, Flsh [Ezhp/7080]	1
▲	1 392962	Bracket Wldt, Light	1
▲	2 16951	Screw, Hex, .25-20 X 1.25, Sems	4
▲	3 32491	Washer, Flt, .31 Std	4
▲	4 397644	Nut, Isolator, .25-20 Wall Thk .187-.343	4
▲	5 26395-1	Clamp, Cable, Stl, 0.56d X 0.38w, 1h	1
▲	6 06943	Screw, Hex, M06 X 1.0 X 20, 8.8	1
▲	7 32483	Washer, Flt, .25 Sae	2
▲	8 08708	Nut, Hex, Lock, M06 X 1.0, NI	1
▲▽	9 390915	① Lamp Assy, Flsh	1
▲▲	45283	① Lamp, 40vdc, 0.9a	1
▲▲	58520	① Lens, Amber, Light, Flsh	1
▲	10 10632-2	Grommet, Rbr, 0.62id, F/ 0.9h, .12matl	1
▲	11 45272	Guard Wldt, Light, Revl/Flsh	1
▲	12 06943	Screw, Hex, M06 X 1.0 X 20, 8.8	4
▲	13 32483	Washer, Flt, .25 Sae	8
▲	14 08708	Nut, Hex, Lock, M06 X 1.0, NI	4
▲	15 49263	Tie, Cable, Nyl, 11.4l .19w 3.0 Max D	2
▲	16 55248	Mount, Cable Tie	1
▲	17 360973	Screw, Pan, #12-16 X 0.50, F/ Plstc	1
▲	18 26395-2	Clamp, Cable, Stl, 0.38d X 0.38w, 1h	1
▲▽	19 1017250	② Lamp, Strobe, Amb, 12-80 Vdc	1
▲▲	9000846	② Lamp, Bulb, Lamp, Strobe	1
▲▲	9000879	② Lens, Lamp, Amb, Strobe/Flasher	1
▲	20 09244	② Screw, Hex, M5 X 0.8 X 16, 8.8	2
▲	21 19066	② Washer, Flat, #10	2
▲	22 06549	② Nut, Hex, Lock, M5 X 0.8, NI	2
	58518	① Lens, Red, Light, Flsh	1
	58519	① Lens, Blue, Light, Flsh	1
	1027798	② Lens, Red, Option, F/Revl/Flsh Light	1
	1027800	② Lens, Blue, Option, F/Revl/Flsh Light	1

① Serial number (0000000-10221852)

② Serial number (10221853-)

▽ ASSEMBLY

▲ INCLUDED IN ASSEMBLY

Fig. 29 - Backup Alarm Kit

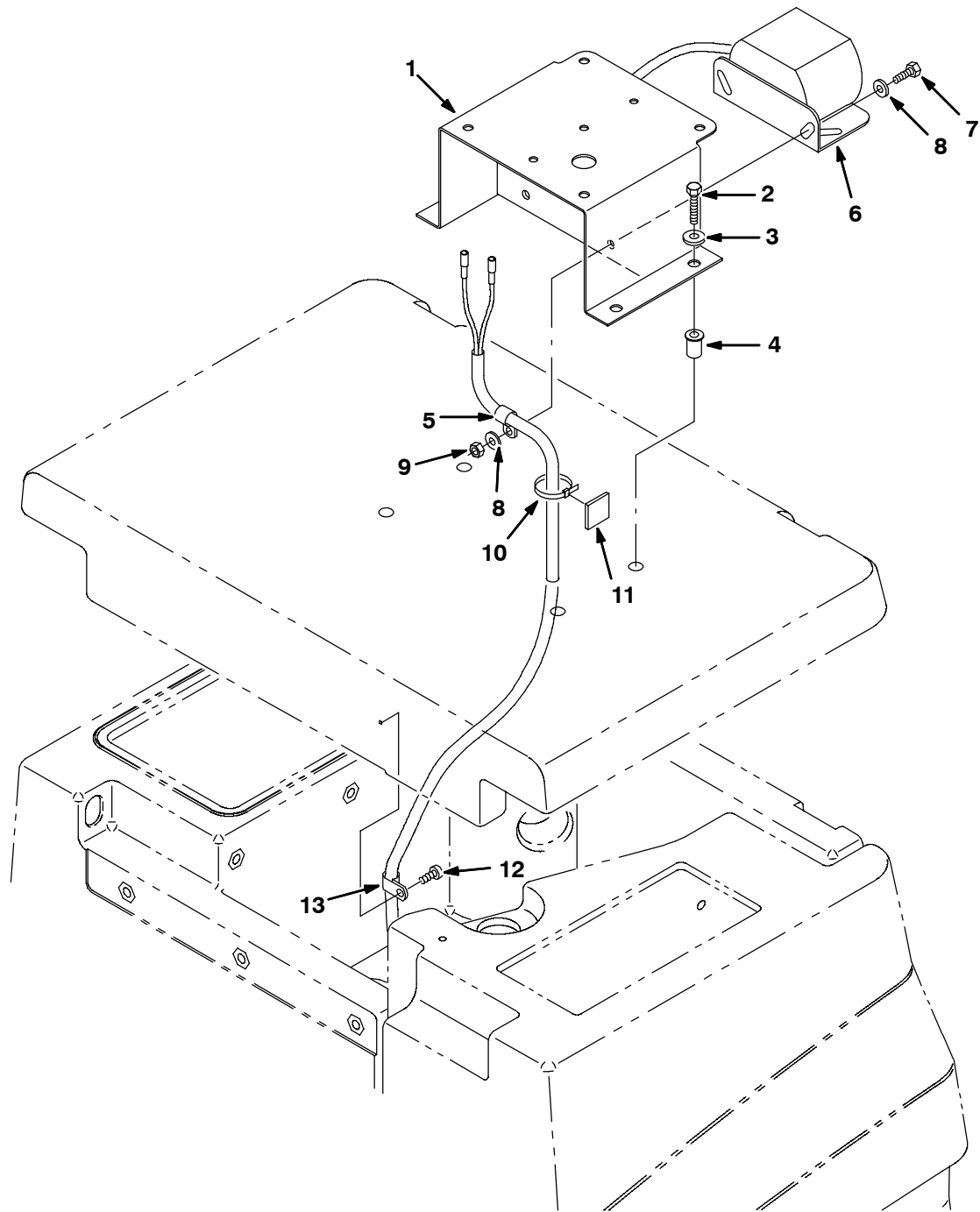

Fig. 29 - Backup Alarm Kit

	Ref.	Nobles- Part No.	Description	Qty.
▽		393042	Kit, Ci, Alarm, Backup, W/ Bracket	1
▲	1	392962	Bracket Wldt, Light	1
▲	2	16951	Screw, Hex, .25-20 X 1.25, Sems	4
▲	3	32491	Washer, Flt, .31 Std	4
▲	4	397644	Nut, Isolator, .25-20 Wall Thk .187-.343	4
▲	5	26395-1	Clamp, Cable, Stl, 0.56d X 0.38w, 1h	1
▲	6	369349	Alarm Assy, Backup, 12-48vdc 82-102dba	1
▲	7	06943	Screw, Hex, M06 X 1.0 X 20, 8.8	2
▲	8	32483	Washer, Flt, .25 Sae	4
▲	9	08708	Nut, Hex, Lock, M06 X 1.0, NI	2
▲	10	49263	Tie, Cable, Nyl, 11.4l .19w 3.0 Max D	2
▲	11	55248	Mount, Cable Tie	1
▲	12	360973	Screw, Pan, #12-16 X 0.50, F/ Plstc	1
▲	13	26395-2	Clamp, Cable, Stl, 0.38d X 0.38w, 1h	1

▽ ASSEMBLY

▲ INCLUDED IN ASSEMBLY

Fig. 30 - Backup Alarm Kit W/O Bracket

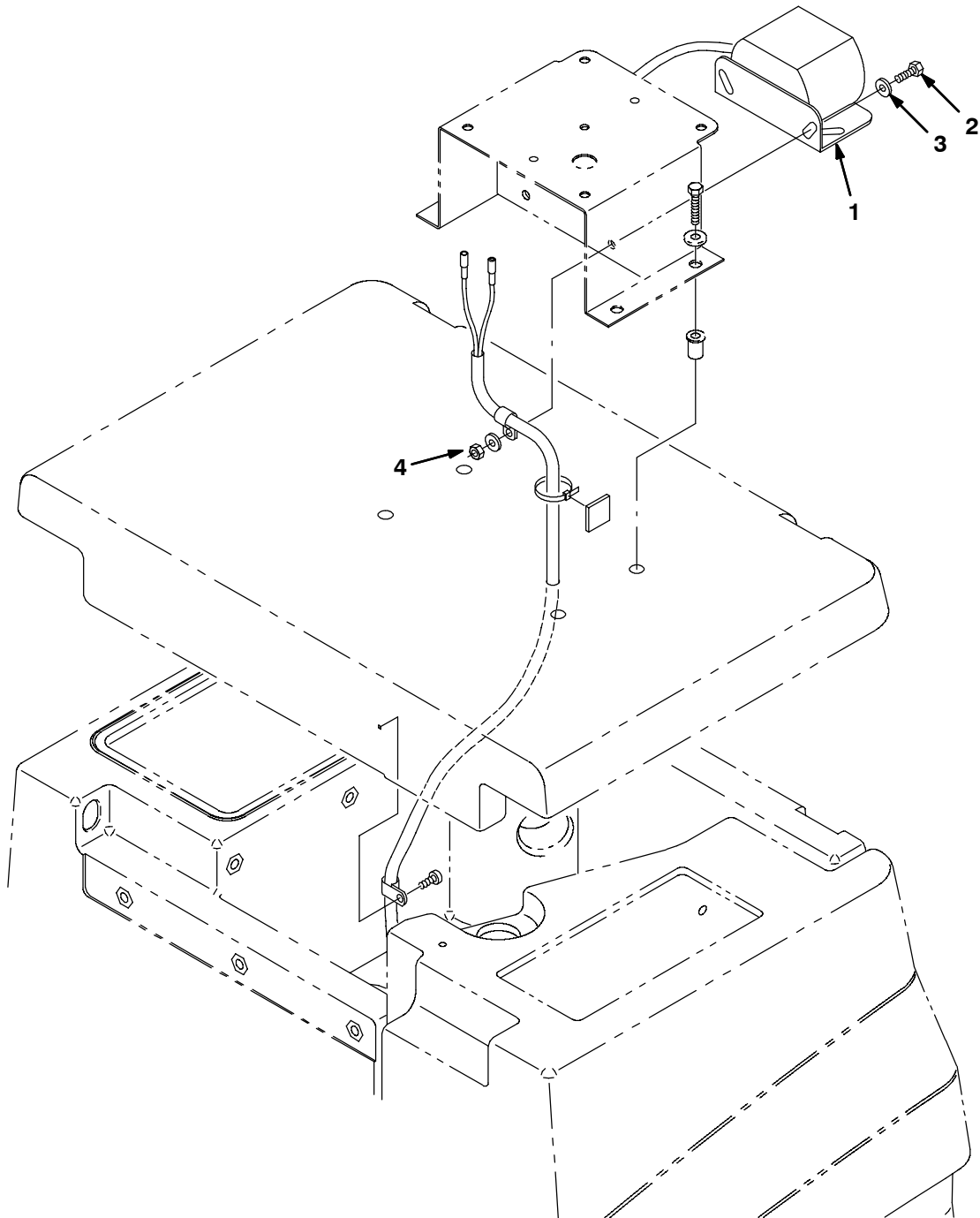

Fig. 30 - Backup Alarm Kit W/O Bracket

	Ref.	Nobles- Part No.	Description	Qty.
▽		393044	Kit, Ci, Alarm, Backup, W/O Bracket	1
▲	1	369349	Alarm Assy, Backup, 12-48vdc 82-102dba	1
▲	2	06943	Screw, Hex, M06 X 1.0 X 20, 8.8	2
▲	3	32483	Washer, Flt, .25 Sae	4
▲	4	08708	Nut, Hex, Lock, M06 X 1.0, NI	2

▽ ASSEMBLY

▲ INCLUDED IN ASSEMBLY

Fig. 31 - Battery Kit, Wet, 244AH

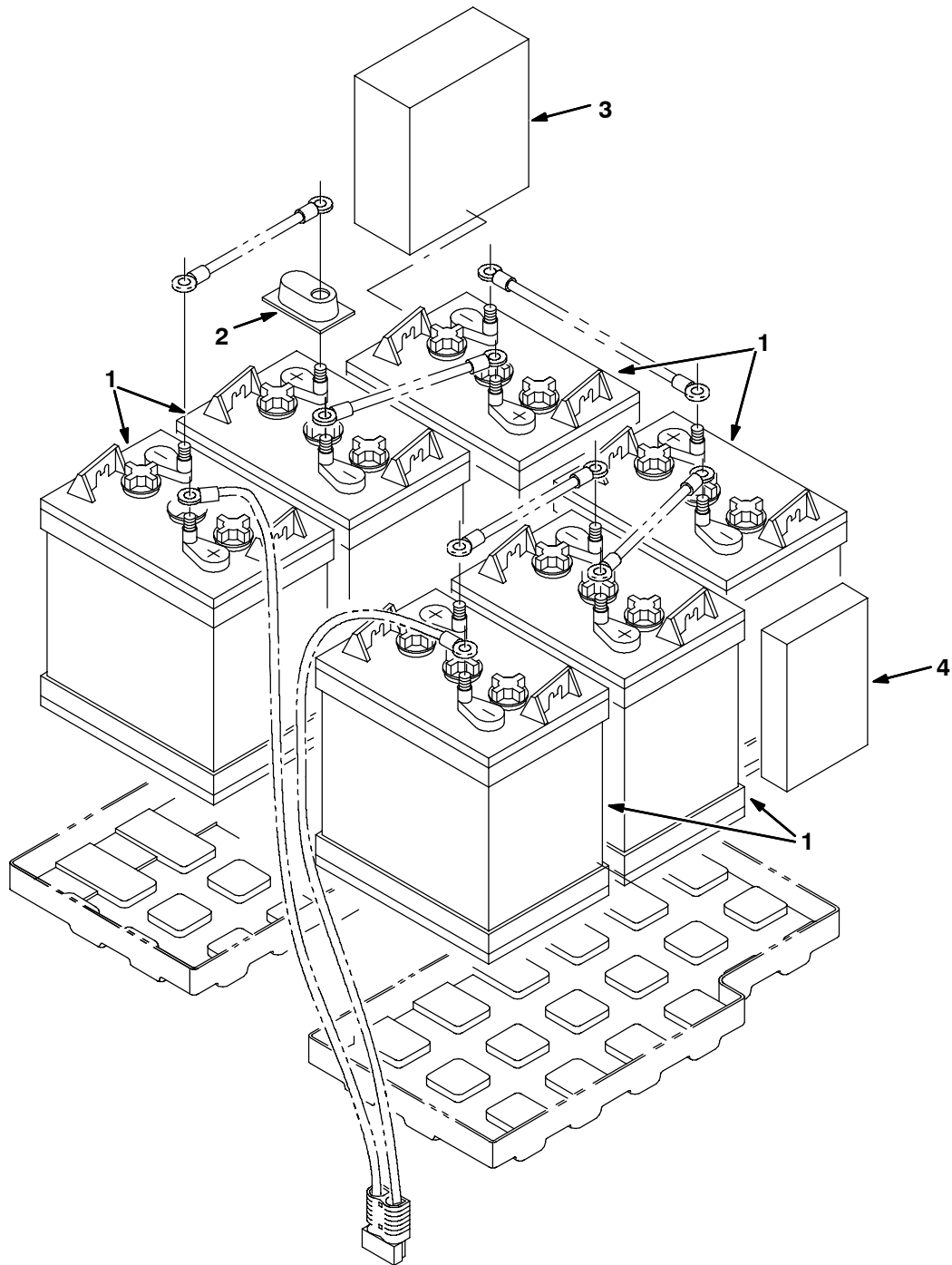

353482 - EZ, 7080

	Ref.	Nobles- Part No.	Description	Qty.
▽		390829	Kit, Ci, Battery, 36vdc, 244ah Wet	1
▲	1	390825	Battery, 06vdc, 244ah, Wet	6
▲	2	45962	Cover, Terminal, Battery, Pye	12
▲	3	391362	Spacer, Foam	1
▲	4	223639	Spacer, Battery 1.50x4.75x7.5	1

▽ ASSEMBLY

▲ INCLUDED IN ASSEMBLY

Fig. 32 - Battery Group, Maintenance Free, 180AH

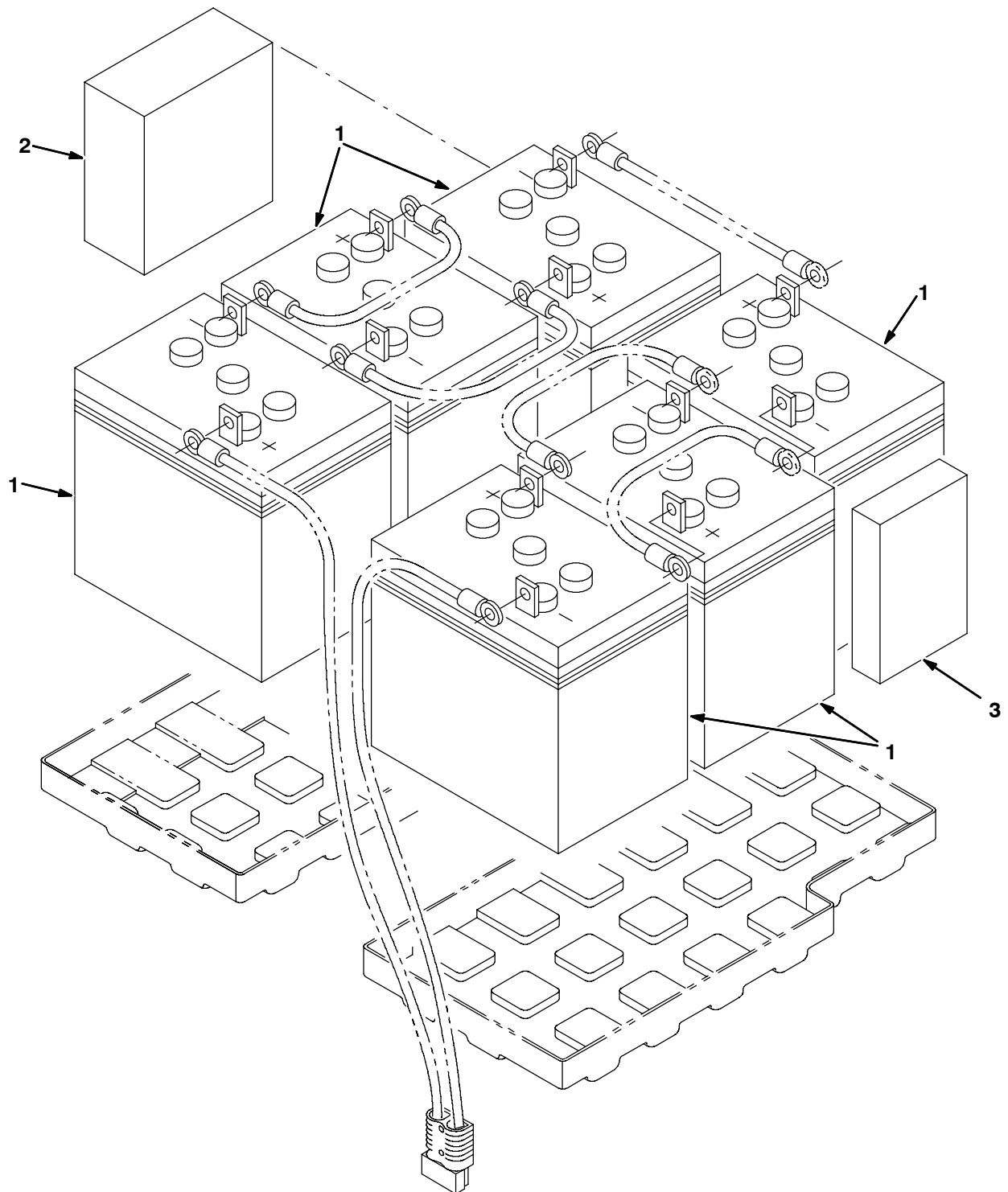

353680 - EZ, 7080

Ref.	Nobles- Part No.	Description	Qty.
1	390764	Battery, 06vdc, 180ah, Maint Free	6
2	391362	Spacer, Battery	1
3	223639	Spacer, Battery 1.50x4.75x7.5	1

Fig. 33 - Battery Charger Group

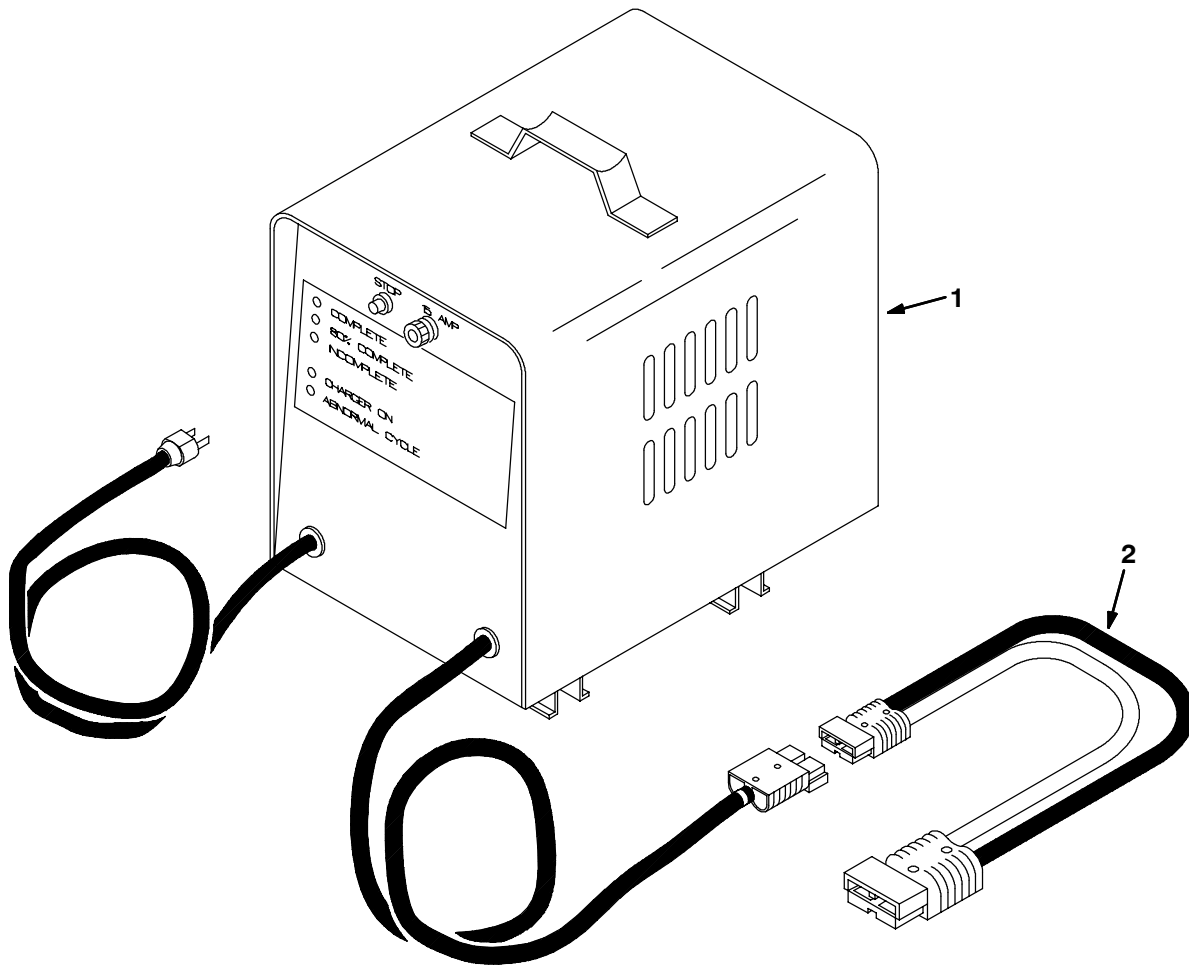

350771 - EZ, 7080

Ref.	Nobles- Part No.	Description	Qty.
1	390767	Charger, 36Vdc, 020A 50/60Hz	1
2	223679	Cable Assy, Battery, 06ga 2, 50a/175a	1
	390841	Kit, Ci, Chrgr, 36vdc 025a 60hz 120vac	1

Fig. 34 - Solid Non-Marking Tire Assembly, Rear

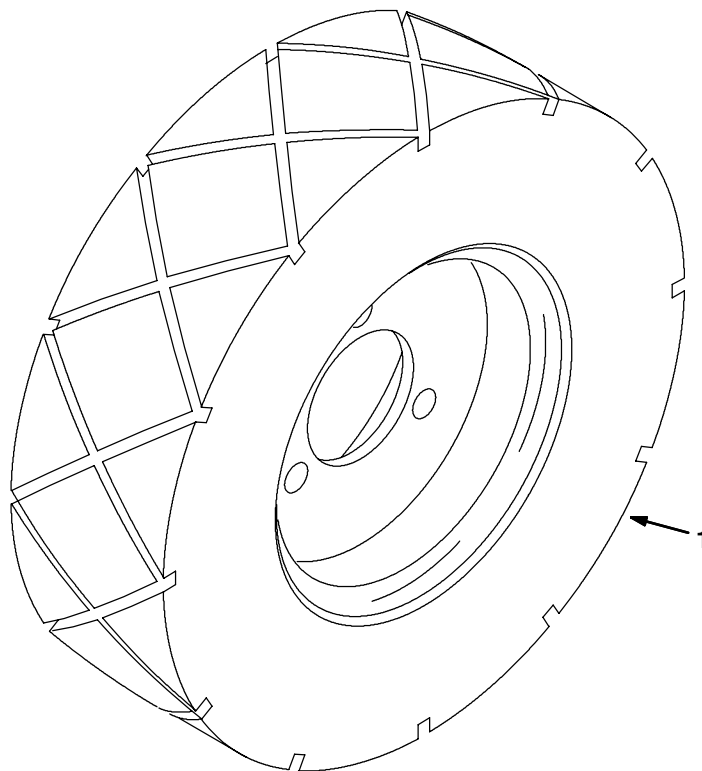

352896 - EZ, 7080

Ref.	Nobles- Part No.	Description	Qty.
1	385766	Tire Assy, Solid, 12.0 X 3.5 3.5Bc/3Bolt	2

Fig. 35 - Documentation Group

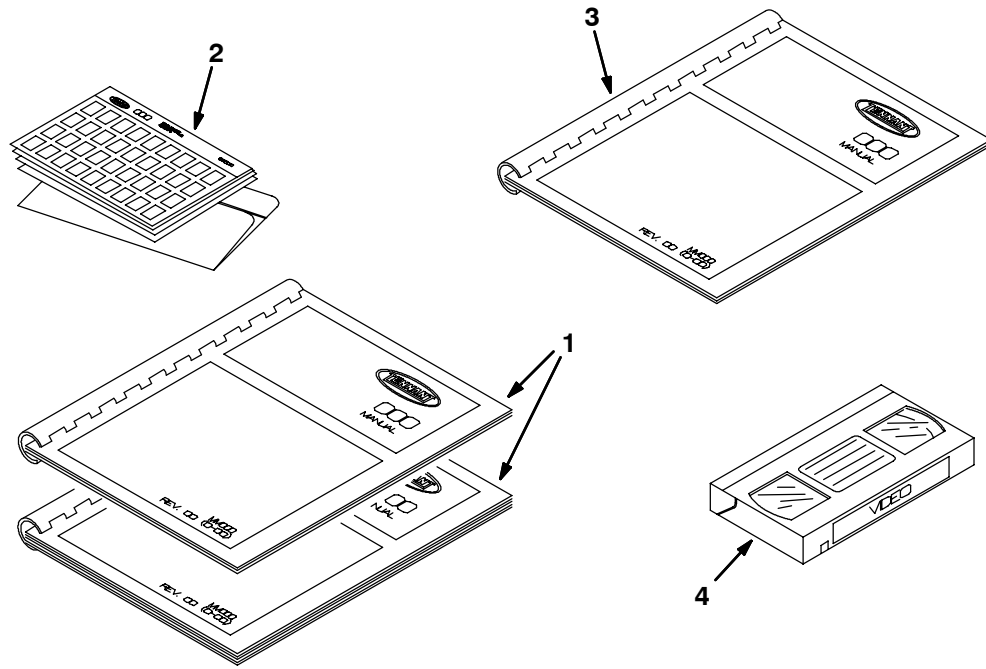

07501 - EZ

Ref.	Nobles- Part No.	Description	Qty.
1	330780	Manual Pkg, [Ez Rider Hp Ele Na]	1
2	330781	Manual, Fiche, [Ez Rider Hp Ele]	1
3	330782	Manual, Oprtr, [Ez Rider Hp Ele Es Na]	1
3	330783	Manual, Oprtr, [Ez Rider Hp Ele Fr Na]	1
4	393168	Video, Operator, Vhs [Ezrider Hp]	1

SECTION 3

Contents	Page
Fig. 1 - Electric Motor Breakdown, 391296	3-2
Fig. 2 - Electric Motor Breakdown, 223358	3-4
Fig. 3 - Electric Motor Breakdown, 374175	3-5
Fig. 4 - Front Wheel Gearbox Breakdown, 390851 (10046634-10160409)	3-6
Fig. 5 - Front Wheel Gearbox Breakdown, 1007541 (10160410-10262871)	3-7
Fig. 6 - Front Wheel Gearbox Breakdown, 374346 (10262872-)	3-8

Fig. 1 - Electric Motor Breakdown, 391296

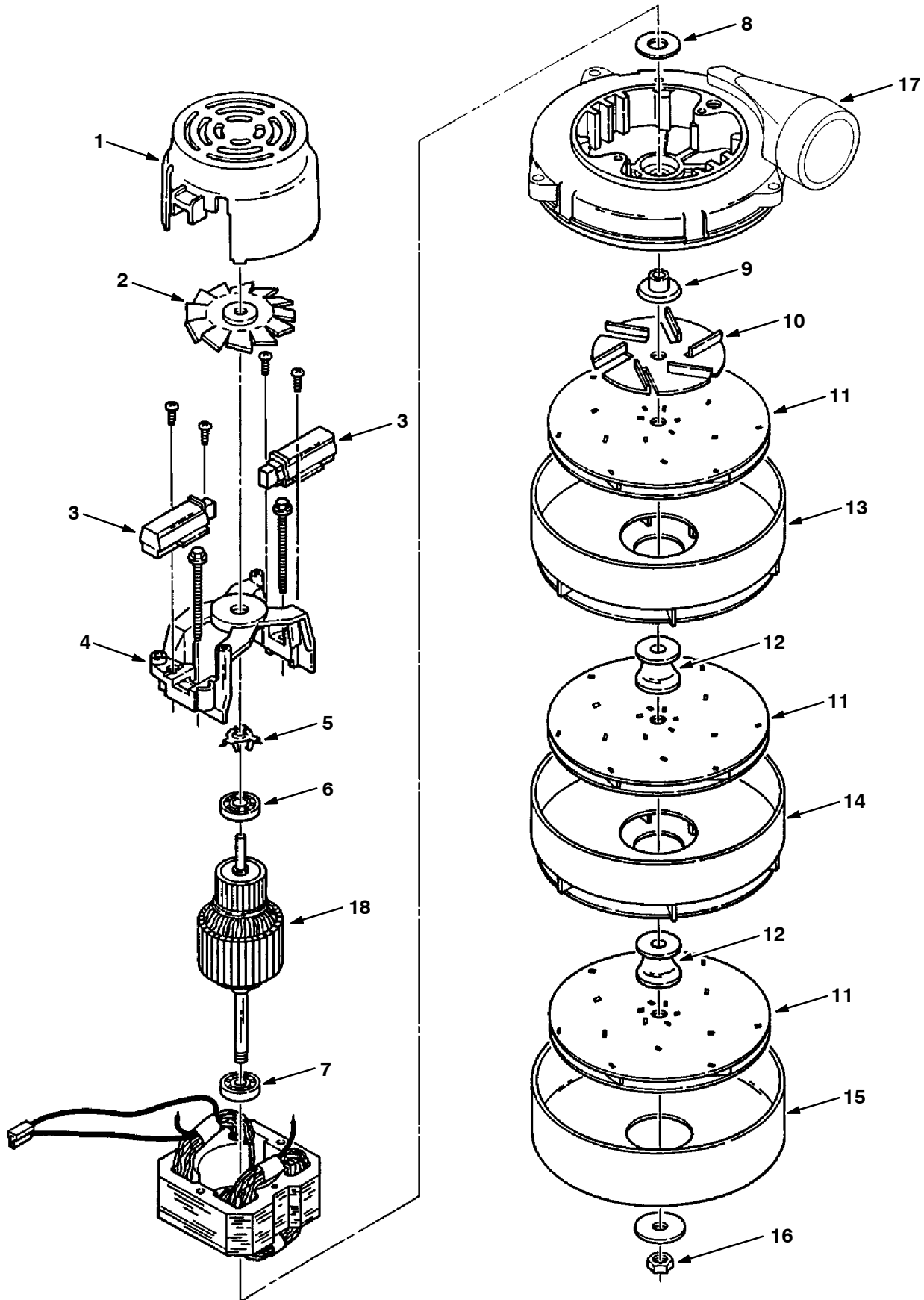

Fig. 1 - Electric Motor Breakdown, 391296

	Ref.	Nobles- Part No.	Description	Qty.
▽		398521	Fan, Vacuum	1
▲	1	398511	Housing	1
▲	2	398512	Fan	1
▲	3	398513	Brush Mechanism	2
▲	4	398514	Comm. Bracket	1
▲	5	01856	Spring	1
▲	6	398515	Bearing	1
▲	7	01837	Bearing	1
▲	8	37912	Washer, Neo.	1
▲	9	398516	Spacer	1
▲	10	01971	Fan	1
▲	11	18628	Vacuum Fan	3
▲	12	398517	Spacer	2
▲	13	61300	Stationary Fan	1
▲	14	61297	Stationary Fan	1
▲	15	398518	Shell	1
▲	16	37929	Nut	1
▲	17	60386	Bracket, Fan End	1
▲	18	398519	Armature	1
▲		391343	Seal, Rbr, Fan, 5.6d 2.0b 1.37l	1
▲		10925	Connector, 2 Conductor	1
▲		10926	Terminal, Female	2
▲		391350	Screen, Fan Inlet	1

▽ ASSEMBLY

▲ INCLUDED IN ASSEMBLY

Fig. 2 - Electric Motor Breakdown, 223358

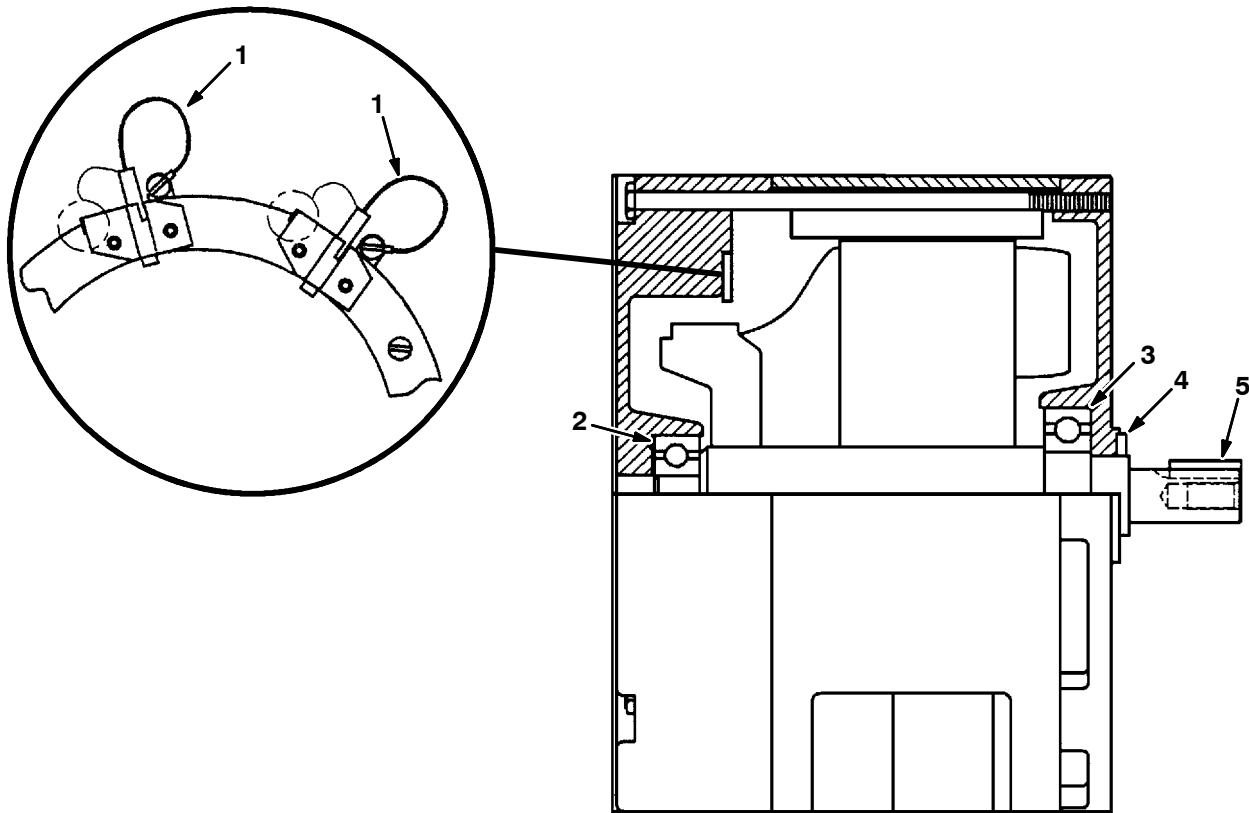

350783

Ref.	Nobles-Part No.	Description	Qty.
▽	223358	Motor, 36 Vdc, 0.8Hp, 320 Rpm	1
▲	1 222606	Brush Kit,	1
▲	2 222618	Bearing	1
▲	3 223351	Bearing Be	1
▲	4 223352	Oil Seal	1
▲	5 00928	Key Square 0.25 0.25 01.00 Lg	1
▲	10925	Connector, 2 Conductor	1
▲	24537	Terminal Female Metri-Pack	2

▽ ASSEMBLY

▲ INCLUDED IN ASSEMBLY

Fig. 3 - Electric Motor Breakdown, 374175

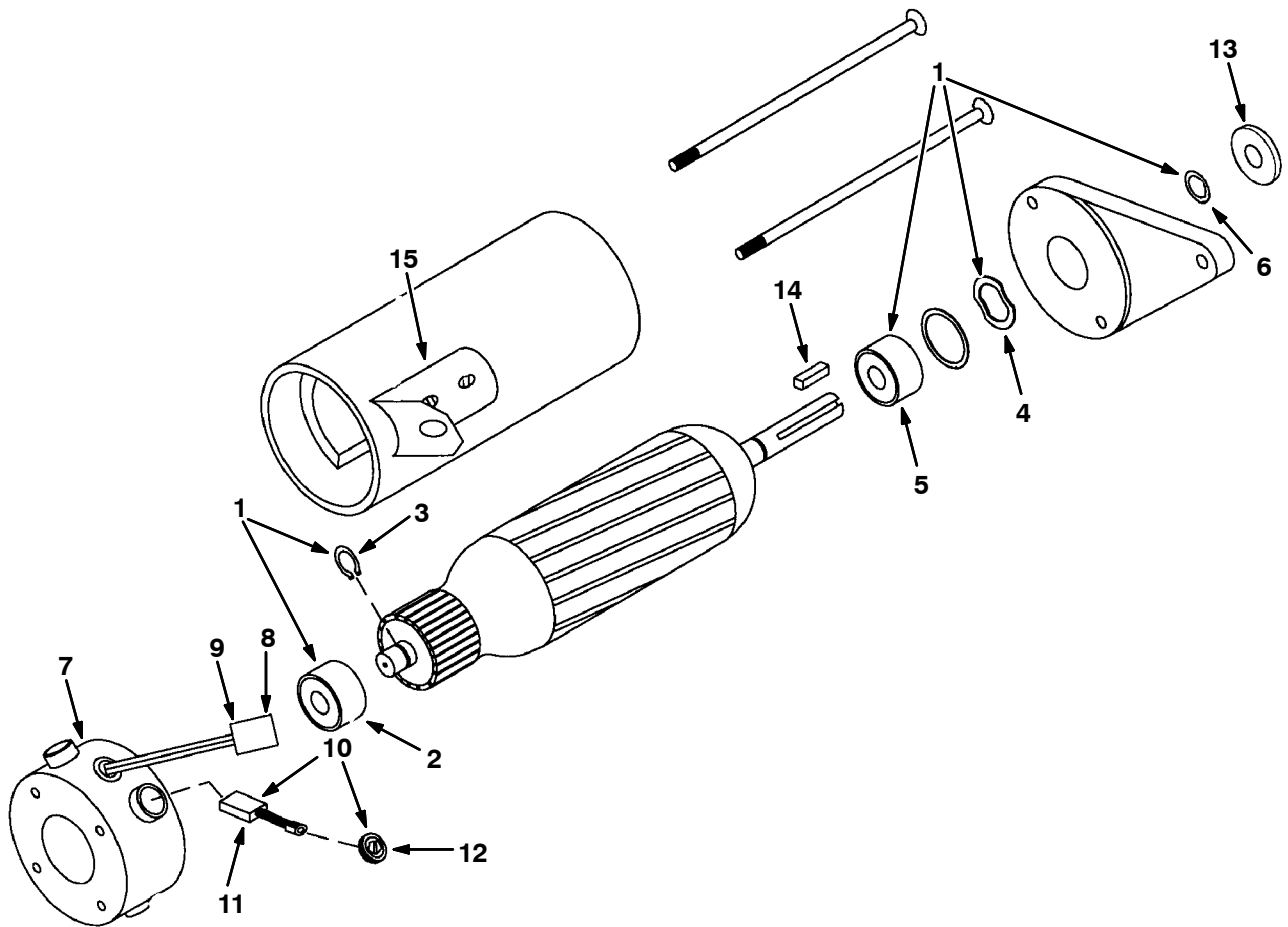

Ref.	Nobles- Part No.	Description	Qty.
▽	374175	Motor Assy, Ele, 36Vdc, 0.75Hp, 1700Rpm	1
▲▽	1 374176	Kit, Motor Bearing	1
▲▲	2 222635	Bearing	1
▲▲	3 222637	Ring, Snap	1
▲▲	4 375177	Washer, Spring	1
▲▲	5 375178	Bearing, Drive End	1
▲▲	6 375179	Seal	1
▲▽	7 374004	Endbell, Brush End, Motor-Ele	1
▲▲	8 10925	Connector, 2-Conductor	1
▲▲	9 24537	Terminal, Female	2
▲▽	10 222625	Kit, Brush	1
▲▲	11 222627	Brush	4
▲▲	12 222629	Cap, Brush Holder	4
▲	13 20536-2	Washer, 0.47b 1.19d .03, Nyl	1
▲	14 00954	Key, Sq, 0.12 X 0.12, 01.00l	1
▲	15 222877	Kit, Brace	1

▽ ASSEMBLY

▲ INCLUDED IN ASSEMBLY

Fig. 4 - Front Wheel Gearbox Breakdown, 390851 (10046634-10160409)

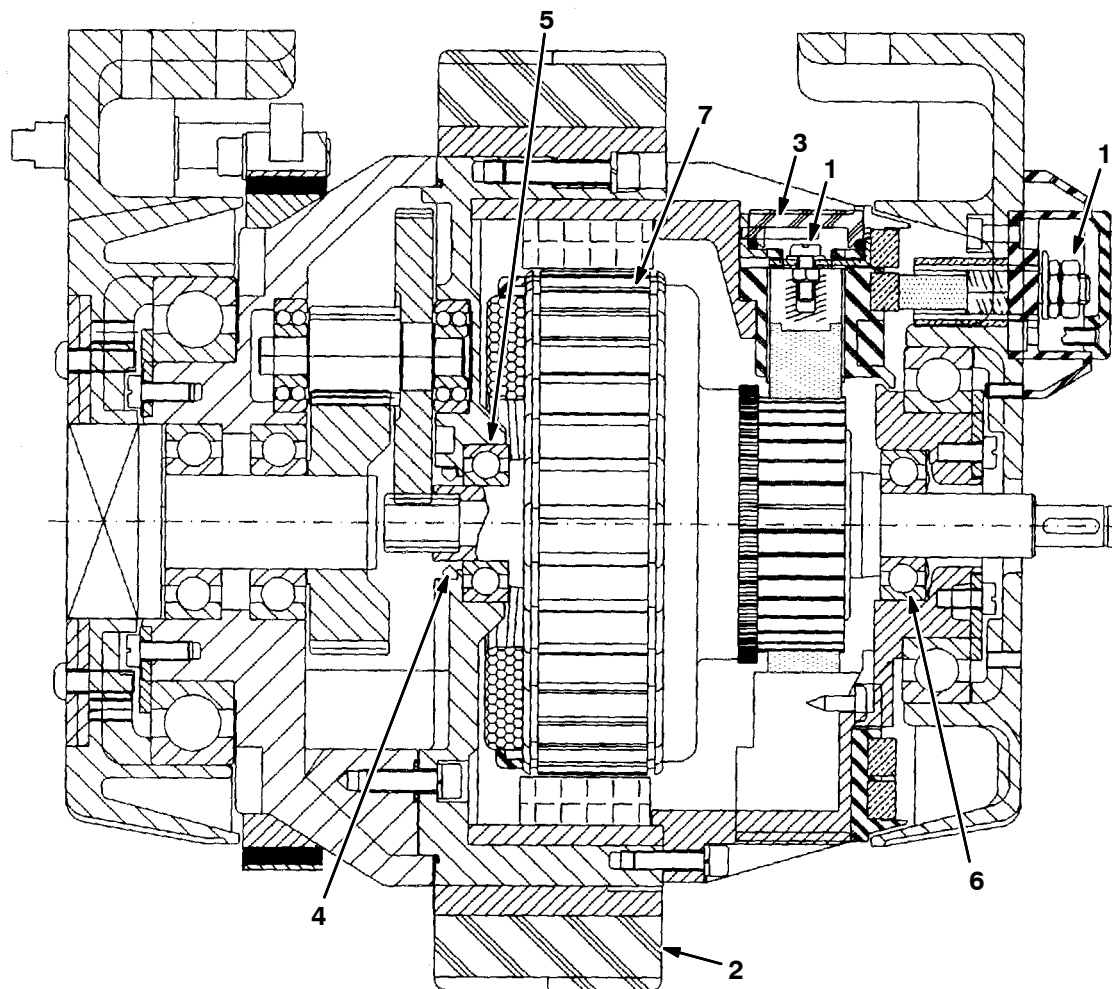

Ref.	Nobles- Part No.	Description	Qty.
▽	390851	Gearbox, Wheel, Front, 250mm	1
▲	1 391261	Kit, Brush, Motor	1
▲	2 391463	Tire, Solid, 250mm x 90mm Grey Pyu	1
▲	3 391262	Kit, Brush, Cover	1
▲	4 391263	Seal, Ring	1
▲	5 391264	Bearing, Gearbox Side	1
▲	6 391265	Bearing, Motor Side	1
▲	7 391266	Armature, Assy, 250mm	1
▲	391271	Caliper, Brake	1
▲	391274	Rotor, Brake, 14mm	1

▽ ASSEMBLY

▲ INCLUDED IN ASSEMBLY

Fig. 5 - Front Wheel Gearbox Breakdown, 1007541 (10160410-10262871)

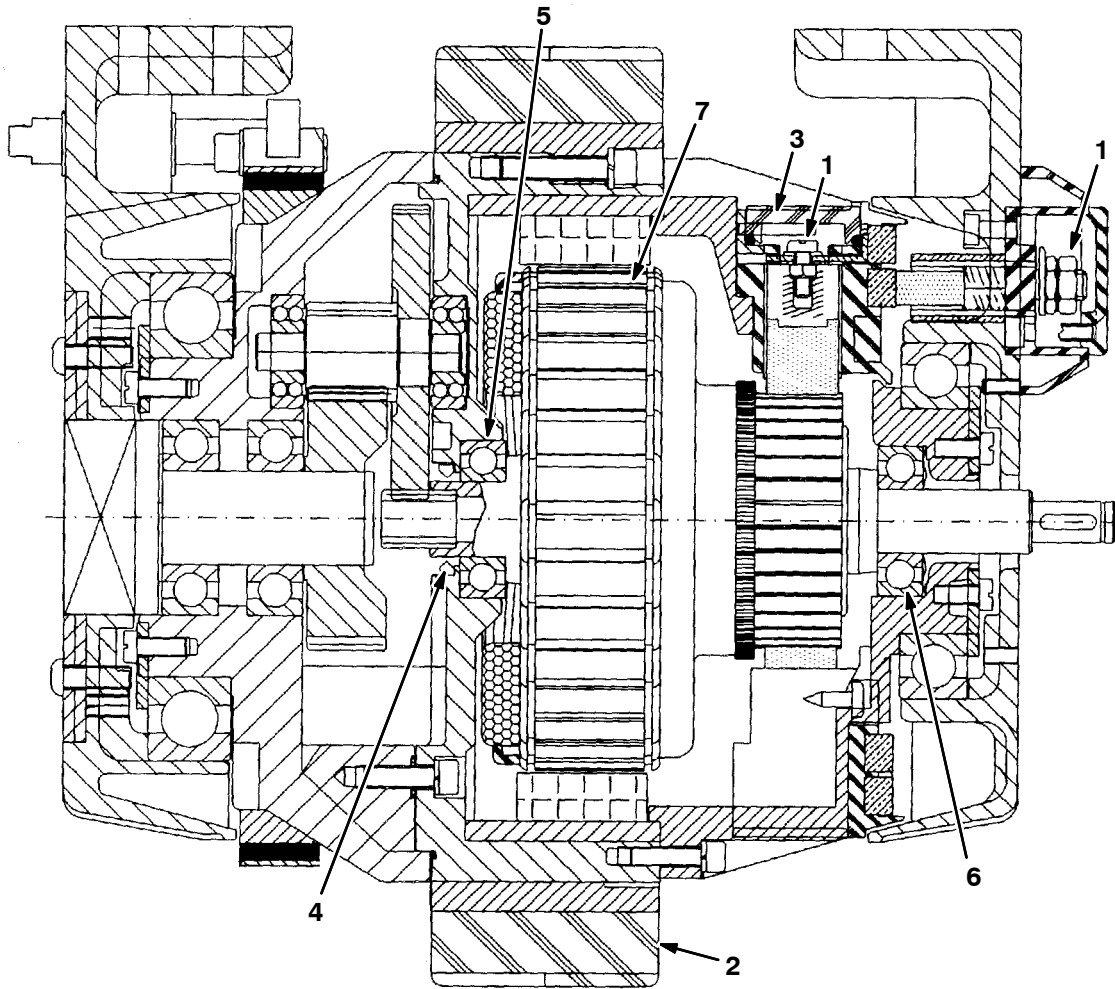

Ref.	Nobles- Part No.	Description	Qty.
▽	1007541	Gearbox, Wheel, 250mm, 36vdc Band Brake	1
▲	1 391261	Kit, Brush, Motor	1
▲	2 391463	Tire, Solid, 250mmx90mm Grey Pyu	1
▲	3 391262	Kit, Brush, Cover	1
▲	4 391263	Seal, Ring	1
▲	5 391264	Bearing, Gearbox Side	1
▲	6 391265	Bearing, Motor Side	1
▲	7 391266	Armature, Assy, 250mm	1
▲	391465	Brake, Band [Amer]	1

▽ ASSEMBLY

▲ INCLUDED IN ASSEMBLY

BREAKDOWNS

Fig. 6 - Front Wheel Gearbox Breakdown, 374346 (10262872-)

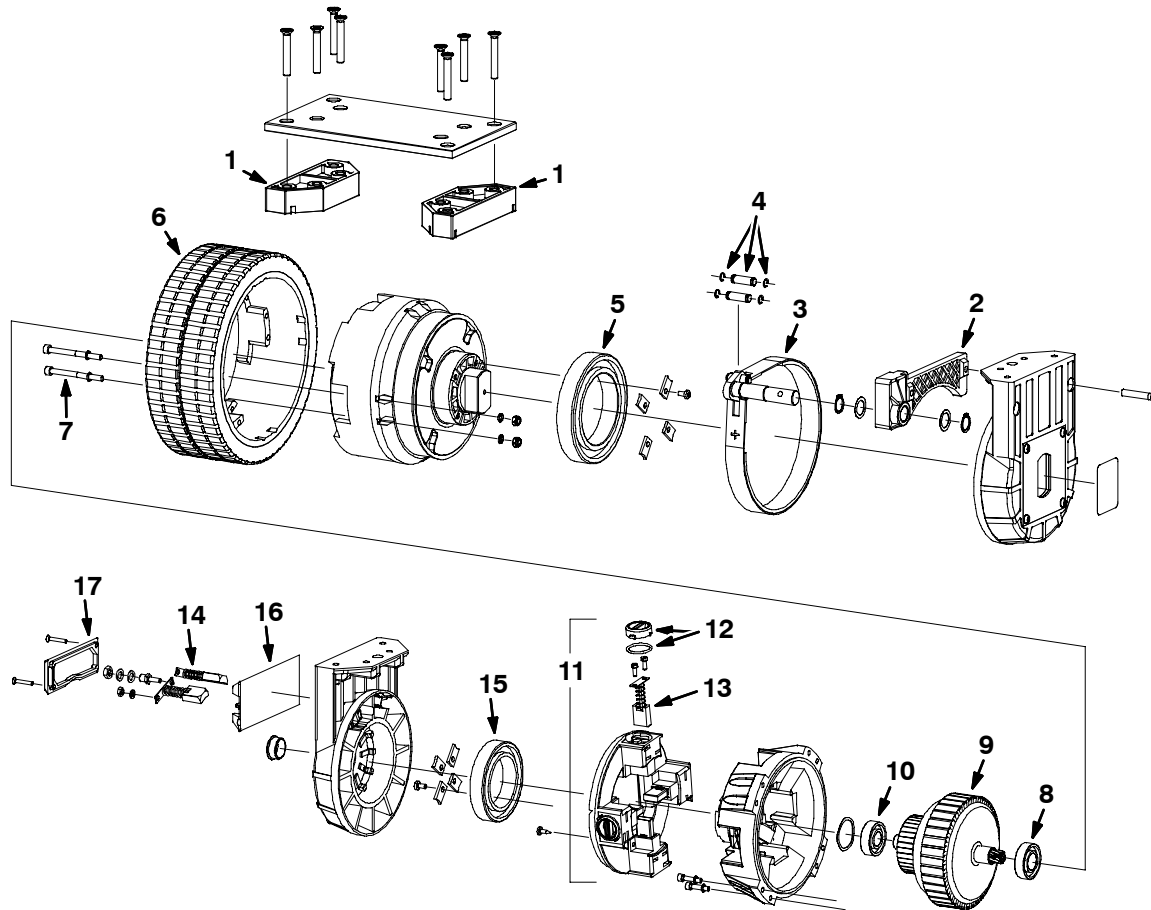

Ref.	Nobles-Part No.	Description	Qty.
▽	374346	Gearbox, Wheel, 250mm, 36vdc Band Brake	1
▲	1 1029223	Spacer, Aluminum	2
▲	2 1029220	Bracket, Brake, Complete	1
▲▽	3 391465	Brake, Band [Amer]	1
▲	4 1030477	Pin Kit, Retainer, Snap Rings	1
▲	5 372874	Bearing, Steering	1
▲	6 391259	Tire, Solid, 250mmx90mm Red	1
	391463	Tire, Solid, 250mmx90mm Gray	1
▲	7 1029218	Screw, Wheel Mount	8
▲	8 391264	Bearing, Gearbox Side [Amer]	1
▲	9 1029217	Armature, Motor, 250mm	1
▲	10 391265	Bearing, Motor Side	1
▲▽	11 1029228	Ring, Brush Holder	1
▲	12 391262AM	Brush Kit, Cover	4
▲	13 1029225	Brush Kit, Carbon	4
▲▽	391261	Brush Kit, Motor	1
▲	13 1029225	Brush Kit, Carbon	4
▲	14 1029226	Brush Kit, Carbon	2
▲	15 1029227	Bearing, Ball, Brush Side	1
▲	16 391467	Box, Elec, Connection	1
▲	17 391468	Cover, Elec, Connection	1

▽ ASSEMBLY

▲ INCLUDED IN ASSEMBLY

SECTION 4

CONTENTS	PAGE
PART NUMBER TO PAGE NUMBER CROSS REFERENCE LIST	4-2
PART DESCRIPTION TO PAGE NUMBER CROSS REFERENCE LIST	4-7

CROSS REFERENCE

PART NUMBER TO PAGE NUMBER CROSS REFERENCE LIST

Part Number	Page Number	Part Number	Page Number	Part Number	Page Number
00912	1-13	08175	1-35, 2-27, 2-35	1005770	1-45
00926	1-31, 1-33	08182	1-23, 1-25, 1-37, 1-49, 2-29, 2-37	1005866	2-9
00928	3-4	08708	1-11, 1-15, 1-21, 2-17, 2-53, 2-55, 2-57, 2-59	1006123	1-31, 1-33, 2-23, 2-25, 2-31, 2-33
00954	3-5	08709	1-13, 1-17, 2-3	1006204	2-7
01516	2-39, 2-45	08711	1-13	1006206	2-7
01684	1-9, 1-31, 1-33, 1-35, 1-37, 1-39, 1-41, 1-45, 1-51, 2-13, 2-15, 2-23, 2-25, 2-27, 2-29, 2-31, 2-33, 2-35, 2-37, 2-39, 2-41, 2-45, 2-47	08712	1-9, 1-19, 1-21, 1-23, 1-31, 1-33, 1-37, 1-41, 1-45, 1-51, 2-23, 2-25, 2-29, 2-31, 2-33, 2-37, 2-41, 2-47	1006415	2-7
01685	1-9, 1-15, 1-19, 1-21, 1-23, 1-39, 1-41, 1-43, 1-47, 1-49, 1-51, 1-53, 2-5, 2-7, 2-13, 2-15, 2-39, 2-41, 2-45, 2-47, 2-51	08713	1-51, 1-53, 2-7, 2-39, 2-45, 2-51	1006447	2-9
01686	1-29, 1-31, 1-33, 1-37, 1-51, 2-3, 2-23, 2-25, 2-29, 2-31, 2-33, 2-37, 2-41, 2-47	08714	1-29, 1-31, 1-33, 2-23, 2-25, 2-31, 2-33	1006723	1-25
01697	1-9	08716	1-9, 1-21, 1-23, 1-31, 1-33, 1-37, 1-41, 1-45, 2-23, 2-25, 2-29, 2-31, 2-33, 2-37	1007541	1-19, 3-7
01754	1-15	09005	1-27	1007845	1-9
01837	3-3	09007	1-9, 1-35, 1-51, 2-27, 2-35, 2-41, 2-47	1008211	2-7
01856	3-3	09010	1-47, 1-51, 2-7	1008388	1-49
01971	3-3	09011	1-53, 2-41, 2-47, 2-51	1008969	1-35, 2-27, 2-35
02076	1-47	09023	2-39, 2-45	1008981	1-35, 2-27, 2-35
02185	1-49, 1-51	09062	1-21	1009603	2-11, 2-13, 2-15
02850	1-25, 2-3	09146	1-15	1010506	2-39, 2-45
02931	2-43, 2-49	09164	1-11	1010560	1-3, 1-53, 2-51
02942	1-29, 1-33, 2-3, 2-25, 2-33	09198	1-5, 1-7	1010668	2-11
02991	1-31, 1-33, 2-23, 2-25, 2-31, 2-33	09228	1-25	1010684	2-11, 2-13, 2-15
02994	2-23, 2-25, 2-31, 2-33	09244	2-53, 2-55	1010713	2-11, 2-13, 2-15
04051	1-29, 1-47	09258	1-47	1010836	2-11, 2-13, 2-15
04414	1-53, 2-51	09291	1-37, 2-29, 2-37	1011403	1-31, 1-33, 2-9, 2-11, 2-13, 2-15, 2-23, 2-25, 2-31, 2-33
05134	2-5	09570	1-9, 1-17	1011521	2-9, 2-11, 2-13, 2-15
05724	1-7	09740	1-9, 1-15, 1-39, 1-41, 1-43, 1-49, 1-51, 2-7, 2-39, 2-45	1012831	2-7
05726	1-7	09767	1-53, 2-51	1013079	2-15
06474A	1-49	1001268	1-35, 2-27, 2-35	1013789	2-7
06549	1-11, 1-17, 2-17, 2-53, 2-55	1001290	1-3, 1-35, 2-27, 2-35	1013902	2-7
06927	2-7	1001959	1-19	1013935	2-9
06932	2-11, 2-13, 2-15, 2-17	1002522	1-23	1014011	2-9
06934	1-11	1002536	1-23	1014082	2-7
06937	1-17	1002537	1-23	1014140	2-21
06943	1-11, 2-53, 2-55, 2-57, 2-59	1002672	1-17	1014436	2-9
06944	1-11	1002789	2-11, 2-13, 2-15	1014673	2-13, 2-15
06945	1-17	1005086	2-11, 2-13, 2-15	1014675	2-9
06957	1-9, 1-21, 1-23	1005199	2-17	1014791	2-13
06962	1-19	1005255	2-7	1014929	1-47
07259	1-19	1005302	2-9	1014957	2-15
07449	2-3	1005304	2-9	1014993	2-13
07790	1-11	1005416	2-21	1015012	1-70
07791	1-11	1005435	2-7	1015033	2-11
08170	1-21, 1-23	1005469	1-53, 2-51	1015365	2-7
		1005508	2-9	1015950	1-31, 2-23
		1005552	2-11, 2-13, 2-15	1015951	2-31
		1005650	1-17	1016045	1-51
				1016832	1-17
				1017019	2-7
				1017025	2-7
				1017248	2-53
				1017250	2-55
				1017439	1-23
				1017440	1-23
				1019764	1-25
				1022253	2-47
				1022254	2-41
				1026017	1-23

CROSS REFERENCE

Part Number	Page Number	Part Number	Page Number	Part Number	Page Number
1026028	1-23	20536-2	3-5	22297	1-41
1027798	2-53, 2-55	21120	2-41, 2-47	22298	1-19
1027800	2-53, 2-55	222055	1-35, 2-27, 2-35	223061	1-13
1029217	3-8	222159	1-19	223065	1-13
1029218	3-8	222167	2-41	223072	1-13
1029220	3-8	222176	2-39, 2-45	223073	1-13
1029223	3-8	222177	2-39, 2-45	223075	1-13
1029225	3-8	222184	2-39, 2-45	223080	1-11
1029226	3-8	222196	1-29, 1-31, 1-33, 2-23, 2-25, 2-31, 2-33	223153	1-19
1029227	3-8	222197	1-35, 2-27, 2-35	223154	1-19
1029228	3-8	222201	1-3	223157	1-19
1030477	3-8	222203	2-41	223159	1-19
10573	2-5	222204	2-47	223160	1-19
10632-2	2-53, 2-55	222209	2-39, 2-45	223161	1-19
10632	1-25	222233	1-51	223198	1-25
10925	3-3, 3-4, 3-5	222236	1-51	223304	2-49
10926	3-3	222244	1-53, 2-51	223330	1-11
10959	1-31, 1-33, 2-23, 2-25, 2-31, 2-33	222268	1-53, 2-51	223351	3-4
11109	1-27	222290	2-19	223352	3-4
11211	1-29	222304	1-3, 1-5	223355	1-47
11635	2-13, 2-15	222305	1-5	223356	1-47
12273	1-11, 1-39, 1-43, 1-49, 2-13, 2-15	222306	1-5	223358	2-23, 2-25, 2-31, 2-33, 3-4
12274	1-25	222307	1-3, 1-7	223361	1-47
12323	2-3	222308	1-7	223412	2-41, 2-47
13248	1-9, 1-11, 1-39, 1-43	222309	1-7	223413	2-49
13534	1-27	222320	1-5	223517	1-29
140027	1-53, 2-51	222321	1-5	223518	1-29
140308	1-43	222322	1-5	223560	2-39, 2-45
140608	1-23	222324	1-5	223561	2-39, 2-45
14799	1-13	222325	1-3, 1-5	223563	2-39, 2-45
14838	1-5, 1-7	222326	1-5	223564	2-39, 2-45
150100	2-9	222327	1-5	223566	2-39, 2-45
15047	1-37, 2-3, 2-29, 2-37, 2-43, 2-49	222374	1-45	223568	1-3, 2-39, 2-45
150516	1-47	222460	1-53, 2-51	223569	1-3, 2-39, 2-45
150525	2-7	222497	1-41	223599	1-11
15539	1-5, 1-7	222504	1-19	223621	1-25
15648	1-31, 1-33, 1-49, 2-3, 2-23, 2-25, 2-31, 2-33, 2-41, 2-47	222523	2-41, 2-47	223639	2-60, 2-61
15675	2-7	222606	3-4	223645	1-33, 2-25
15678	1-19, 1-39, 2-39, 2-45	222618	3-4	223679	2-62
16213	1-25	222625	3-5	22892	1-47
16236	1-37, 2-29, 2-37	222627	3-5	23191	1-53, 2-51
16930	1-19	222629	3-5	24299	1-5, 1-7
16931	1-9, 1-11	222635	3-5	24537	3-4, 3-5
16951	2-53, 2-55, 2-57	222637	3-5	24672	1-31, 1-33
17188	1-43, 2-5, 2-9	222669	2-41, 2-47	24989	1-19
17461	1-29	222670	2-41, 2-47	25537	1-11
18628	3-3	222683	1-15	25709	1-37, 2-29, 2-37, 2-43, 2-49
19064	2-7	222742	1-45	25735	1-51
19065	1-25	222751	2-39, 2-45	26395-1	1-9, 1-19, 2-53, 2-55, 2-57
19066	1-25, 2-17, 2-53, 2-55	222752	2-39, 2-45	26395-2	2-53, 2-55, 2-57
19324	1-11, 1-17, 2-11, 2-13, 2-15	222793	1-43	29558	1-25, 1-49
19588	2-43, 2-49	222794	1-53, 2-51	30241	1-7
20171	1-31, 2-23, 2-31, 2-41, 2-47	222818	2-39, 2-45	32483	1-9, 1-11, 1-15, 1-17, 1-19, 1-25, 2-53, 2-55, 2-57, 2-59
		222820	2-39, 2-45		
		222822	1-39, 2-5		
		222824	2-41		
		222825	2-47		
		222836	2-33		
		222877	3-5		

CROSS REFERENCE

Part Number	Page Number	Part Number	Page Number	Part Number	Page Number
32486	1-25, 1-29, 1-31, 1-33, 2-23, 2-25, 2-31, 2-33, 2-41, 2-47	375179	3-5	390773	1-3, 1-53, 2-51
32490	1-11, 1-13, 1-17, 1-19, 1-29, 1-39, 1-43, 2-17	375195	2-39, 2-45	390785	1-19
32491	1-11, 2-3, 2-53, 2-55, 2-57	375411	1-11	390788	1-13
32492	1-23, 1-25, 2-3	377333	2-39, 2-45	390800	1-9
32493	1-13	377364	1-33, 2-25, 2-33	390822	1-39, 1-43
32980	2-11, 2-13, 2-15	377374	1-31, 2-23, 2-31	390825	2-60
32982	1-17	377393	1-47	390829	2-60
32983	1-11	377411	1-21, 1-23, 1-25	390841	2-62
330780	2-64	377433	1-15	390848	1-19
330781	2-64	377505	2-39, 2-45	390849	1-31, 1-33
330782	2-64	37912	3-3	390851	1-19, 3-6
330783	2-64	379202	2-39, 2-45	390855	1-19
33925	2-43, 2-49	37929	3-3	390856	1-21
33930	1-41	380587	2-43, 2-49	390857	1-21
33944	2-17	382264	1-11	390879	1-19, 1-47, 1-51
360369	1-11	383721	2-17	390880	1-49
360370	1-11	384265	2-3	390882	1-3, 1-39
360930	1-41	384287	2-3	390883	1-3, 1-39
360973	1-9, 1-15, 2-53, 2-55, 2-57	384418	2-3	390892	1-21
361074	1-15	384419	2-3	390893	1-21
361339	1-19	385665	2-5	390895	1-21
36191	1-21, 1-23	385728	1-25	390905	1-27
363087	1-25	385729	1-25	390915	2-55
363468	2-39, 2-45	385766	2-63	390916	2-53
363503	1-11	386326	1-39	390920	2-51
363976	2-3	39005	1-25, 1-49, 1-53, 2-51	390922	1-3, 2-51
363981	1-25	39019	1-37, 2-3, 2-29, 2-37, 2-43, 2-49	390923	1-3, 2-51
364631	1-45, 2-9	390633	1-3, 1-31, 1-33, 2-23, 2-25	390924	2-51
365095	2-5	390634	1-3, 1-31, 1-33, 2-23, 2-25	390933	1-31, 1-33, 2-23, 2-25, 2-31, 2-33
36643	1-29	390635	1-31, 1-33, 2-23, 2-25	390934	1-3, 2-51
369345	1-27	390636	1-31, 1-33, 2-23, 2-25	390936	1-3, 1-53
369349	2-57, 2-59	390641	2-41	390940	1-53
369460	2-39, 2-45	390650	1-3, 2-31, 2-33	390942	1-3, 1-53
369865	2-5	390651	1-3, 2-31, 2-33	390943	1-3, 1-53
370091	1-5	390652	2-31, 2-33	390944	1-53
370092	1-7	390653	2-31, 2-33	390946	1-3, 1-39
370095	1-5, 1-7	390665	1-29	390965	1-49
370100	1-53, 2-51	390666	1-31, 2-23, 2-31, 2-41, 2-47	390970	1-49
372874	3-8	390667	2-47	390975	1-51
374004	3-5	390670	1-53	390982	1-53, 2-51
374006	2-41	390671	2-51	390988	1-37, 2-29, 2-37
374007	2-47	390677	1-41	390989	1-49
374041	1-5	390681	1-9	390994	1-43
374042	1-7	390694	1-11	390996	2-39, 2-45
374175	2-39, 2-45, 3-5	390696	1-9	390997	1-37, 2-29, 2-37
374176	3-5	390702	1-37, 2-29	391051	2-3
374225	1-25	390707	1-37, 2-29, 2-37	391115	2-5
374299	1-19	390710	1-37, 2-29	391146	1-39
374333	1-3	390720	1-37, 2-29, 2-37	391147	1-9
374334	1-3	390730	2-33	391176	2-43, 2-49
374335	1-3	390734	2-37	391179	1-37, 2-29, 2-37
374336	1-3	390736	2-37	391257	2-3
374346	1-19, 3-8	390741	1-33, 2-25, 2-33	391259	3-8
375177	3-5	390764	2-61	391261	3-6, 3-7, 3-8
375178	3-5	390767	2-62	391262	3-6, 3-7
		390769	1-11	391262AM	3-8
				391263	3-6, 3-7
				391264	3-6, 3-7, 3-8
				391265	3-6, 3-7, 3-8

CROSS REFERENCE

Part Number	Page Number	Part Number	Page Number	Part Number	Page Number
391266	3-6, 3-7	392840	1-35, 2-27, 2-35	393135	1-13, 1-17
391271	3-6	392841	1-35, 2-27, 2-35	393143	1-70
391274	3-6	392842	1-3, 1-35, 2-27, 2-35	393149	1-61, 1-65
391287	2-3	392846	1-11	393150	1-45
391296	1-41	392874	1-45	393151	1-29
391297	1-70	392877	1-15	393159	1-61, 1-65, 1-69
391300	1-19	392878	1-43	393160	1-61, 1-65, 1-69
391304	1-9	392881	1-49, 1-51	393161	1-65, 1-69
391309	1-41	392882	1-31, 1-33, 2-23, 2-25, 2-31, 2-33	393162	1-65, 1-69
391317	1-43			393164	1-31, 2-23
391318	1-43	392887	1-29	393165	2-31
391319	1-43	392891	1-61	393168	2-64
391327	2-43	392892	1-19	393170	1-15
391328	2-43	392894	1-15	39658	1-15
391330	2-47	392895	1-17	397644	2-53, 2-55, 2-57
391334	1-3, 2-43	392896	1-15	397889	1-15, 2-17
391338	1-39	392897	1-15	397914	1-3, 1-5
391341	1-39	392901	1-43	397916	1-3, 1-7
391343	1-3, 1-41, 3-3	392902	1-51	397974	1-5
391345	1-37, 2-29, 2-37, 2-43, 2-49	392904	1-31, 2-23, 2-31	397976	1-7
391346	1-37, 2-29, 2-37, 2-43, 2-49	392917	1-70	398501	1-15
391350	1-41, 3-3	392933	2-41, 2-47	398511	3-3
391351	1-39	392934	1-51	398512	3-3
391362	2-60, 2-61	392937	1-9	398513	3-3
391368	1-41	392946	2-5	398514	3-3
391370	1-33, 2-25	392951	1-39	398515	3-3
391372	1-39	392952	1-39	398516	3-3
391377	1-3, 1-53	392955	1-45	398517	3-3
391378	1-3, 1-53	392962	2-53, 2-55, 2-57	398518	3-3
391379	1-3, 2-51	392963	1-43	398519	3-3
391380	1-3, 2-51	392966	1-25	398521	3-3
391381	1-13	392967	1-29	398526	2-17
391382	1-27	392968	1-21	40678-1	1-11
391383	1-3, 2-51	392980	1-53	40758	1-51
391384	1-3, 1-53	392981	2-51	41178	1-11, 1-19
391385	1-3, 2-51	392988	1-53	41186	1-31, 1-33, 2-23, 2-25, 2-31, 2-33
391386	1-3, 1-53	392989	2-51		
391401	1-13	393016	2-41, 2-47	41187	1-13
391403	1-39	393017	2-43, 2-49	41360	2-39, 2-45
391434	1-41	393018	2-43, 2-49	41430	1-25, 2-3
391449	2-7	393023	1-29	41578	1-39
391451	2-21	393027	1-41	41619	1-49
391463	3-6, 3-7, 3-8	393028	1-41	44078	1-15
391465	3-7, 3-8	393029	1-9	44681-1	2-53
391467	3-8	393042	2-57	44681-2	2-53
391468	3-8	393044	2-59	44681	2-53
391899	2-19	393048	2-53	44906	1-31, 1-37, 2-23, 2-29, 2-31, 2-37, 2-43, 2-49
391911	2-19	393049	2-55		
392171	1-15	393100	2-5	44961	1-31, 1-33, 2-23, 2-25, 2-31, 2-33, 2-39, 2-45
39277	1-29	393102	2-5		
392816	1-29	39311	2-3	45272	2-53, 2-55
392818	1-11	393112	1-15	45283	2-53, 2-55
392822	1-11	393117	1-47	45960	1-29
392823	1-35, 2-27, 2-35	393118	1-47	45962	1-47, 2-60
392827	1-15	39312	2-3	46820	1-13
392838	1-15	393125	1-47	49225	1-19
392839	1-15	393129	1-9, 1-39, 1-43	49263	2-53, 2-55, 2-57
39284	1-13, 1-25	393130	1-11	49266	1-39, 2-5
		393133	1-39	49694	1-39, 1-43
		393134	1-15	49697	2-3

CROSS REFERENCE

Part Number	Page Number	Part Number	Page Number	Part Number	Page Number
49800	1-39	69461	1-11	86866	1-21, 1-23, 1-29
49826	2-5	69582	1-37, 2-29, 2-37, 2-43, 2-49	87308	1-17
50269	1-29, 1-31, 1-49, 1-51, 2-23, 2-31, 2-41, 2-47	69785	2-5	87435	1-47
50682	1-29	71090	1-51	87816	2-3
51109	1-25	71211	1-51	9000705	1-25
51225-1	2-3	71607	1-37, 2-29, 2-37, 2-43, 2-49	9000845	2-53
51534	1-29	71793	2-41, 2-47	9000846	2-55
53268	2-9	73342	2-5	9000879	2-53, 2-55
53466	2-7	73468	2-5	97031	1-25
54333	1-33, 1-45, 2-9, 2-11, 2-13, 2-15, 2-23, 2-25, 2-31, 2-33, 2-41, 2-47	74455	1-25, 2-41, 2-47		
54745	1-25	75371	1-49		
55248	1-39, 2-5, 2-53, 2-55, 2-57	75611	1-39		
578441	1-43	75934	1-25		
58484	1-11	76099	2-39, 2-41, 2-43, 2-45, 2-47, 2-49		
58518	2-55	76438	2-3		
58519	2-55	77347	2-3		
58520	2-55	78553	1-15		
58979	1-41	78840	2-5		
59668	2-41, 2-47	78841	2-5		
603012	1-39	78842	2-5		
60386	3-3	79246	1-37, 2-29, 2-37, 2-43, 2-49		
606370	1-3, 1-15	79273-1	2-11, 2-13, 2-15		
607776	1-31	79506	2-39, 2-45		
608562	1-49	80317	2-3		
611287000	1-31, 1-33	80318	2-3		
61297	3-3	81537	2-3		
61300	3-3	81538	2-3		
613727	2-7	81539	2-3		
613735	2-7	81540	2-3		
614265	1-45	81541	2-3		
621324	1-43	81542	2-3		
626100	1-45	81580	1-9, 1-39, 1-43		
626121	1-45	81672	1-25		
630068	1-43	82138	1-53, 2-51		
630394	1-43	82829	2-7		
63245-1	1-31, 1-33, 2-23, 2-25, 2-31, 2-33, 2-41, 2-47	82839	1-25		
63248-1	1-7	82889	1-31, 2-23, 2-31, 2-41, 2-47		
63248-2	1-7	83097	1-19, 1-29		
63248-3	1-3, 1-7	83149	1-25		
63248-4	1-7	83332	2-3		
63416	1-51	83347	2-3		
63810	2-5	83348	2-3		
63987-1	2-9, 2-13, 2-15, 2-41, 2-47	86240	1-23		
64173	1-37, 2-29, 2-37, 2-43, 2-49	86759	1-37, 2-29, 2-37, 2-43, 2-49		
64425	1-37, 2-3, 2-29, 2-37, 2-43, 2-49	86780	1-31, 2-23, 2-31, 2-41, 2-47		
64743	2-9, 2-13, 2-15	86781	1-31, 2-23, 2-31, 2-41, 2-47		
64778	2-9	86859	1-3, 1-37, 2-29, 2-37, 2-49		
65441	2-3	86860	1-37, 2-3, 2-29, 2-37, 2-43, 2-49		
65695	1-35, 2-27, 2-35	86865	1-3, 1-37, 2-29, 2-37, 2-43, 2-49		
67767	1-9, 1-19, 1-43, 1-47, 1-51				
69234	1-9, 1-17				

PART DESCRIPTION TO PAGE NUMBER CROSS REFERENCE LIST

A

Actuator, 36vdc, 02.0stroke 300lb, 1-49
 Adaptor, Brush, 1-5, 1-7
 Alarm Assy, Backup, 12-48vdc
 82-102dba, 2-57, 2-59
 Angle Wldt, Stop, Side Sqge, Cyl, Head,
 2-43, 2-49
 Angle Wldt, Tool, Lift, Cyl, 28 Inch, 2-41
 Angle Wldt, Tool, Lift, Cyl, 32 Inch, 2-47
 Angle, Bracket, Tank, 1-43
 Angle, Lh, 1-35, 2-27, 2-35
 Angle, Rh, 1-35, 2-27, 2-35
 Angle, Rod, Prop, 1-11
 Arm Wldt, Brake, 1-21, 1-23
 Arm Wldt, Lift, Mop, Lh, 2-3
 Arm Wldt, Lift, Mop, Rh, 2-3
 Arm, Link, Brake, Lh, 1-21, 1-23
 Arm, Link, Brake, Rh, 1-21, 1-23
 Arm, Mtg, Link, Lh Sqge, Cyl Head, 2-43,
 2-49
 Arm, Mtg, Link, Rh Sqge, Cyl Head, 2-43,
 2-49
 Armature, Assy, 250mm, 3-6, 3-7
 Armature, Motor, 250mm, 3-8
 Armature, 3-3

B

Battery, 06vdc, 244ah, Wet, 2-60
 Battery, 06vdc, 180ah, Maint Free, 2-61
 Bearing Assy, Cup/Cone, 1-19
 Bearing Be, 3-4
 Bearing Kit, Front Drive Wheel, Replmt,
 1-19
 Bearing, Ball, 0.59b 1.26d 0.35w, 2-39,
 2-45
 Bearing, Ball, 0.75b 1.38d 0.50w, 1-13
 Bearing, Ball, 0.98b 2.05d 0.59w, 1-27
 Bearing, Ball, Brush Side, 3-8
 Bearing, Cup, 1-19
 Bearing, Drive End, 3-5
 Bearing, Gearbox Side [Amer], 3-8
 Bearing, Gearbox Side, 3-6, 3-7
 Bearing, Motor Side, 3-6, 3-7, 3-8
 Bearing, Steering, 3-8
 Bearing, Thrust, 2.75b 3.63d 0.13w, 1-19
 Bearing, Thrust, 1-37, 2-3, 2-29, 2-37,
 2-43, 2-49
 Bearing, 3-3, 3-4, 3-5
 Bellcrank, Lift, Sqge, 1-37, 2-29, 2-37,
 2-43, 2-49
 Belt, 15mm 05p 500l, 1-3
 Belt, Replmt, Brush Drive, F/222201, 2-39,
 2-45
 Blade, Rear, Gum Rbr, 700mm, 1-3
 Blade Assy, Sqge, Side [Linatex], 1-3, 2-49
 Blade Assy, Sqge, Side, 1-3
 Blade, Sqge, Front, 700mm, Linatex, Red,
 1-53
 Blade, Sqge, Front, 700mm, Linatex, 1-3

Blade, Sqge, Front, 700mm, Oil-Rstn, 1-3
 Blade, Sqge, Front, 700mm, 1-3, 1-53
 Blade, Sqge, Front, 800mm, Linatex, 1-3
 Blade, Sqge, Front, 800mm, Oil-Rstn, 1-3,
 2-51
 Blade, Sqge, Front, Oil-Rstn, 700mm,
 1-53
 Blade, Sqge, Lh, 1-3, 1-35, 2-27, 2-35
 Blade, Sqge, Rear, 700mm, Oil-Rstn, 1-3
 Blade, Sqge, Rear, 700mm, 1-3, 1-53
 Blade, Sqge, Rear, 800mm Linatex, Red,
 2-51
 Blade, Sqge, Rear, 800mm, Oil-Rstn, 1-3,
 2-51
 Blade, Sqge, Rear, 800mm, 1-3
 Blade, Sqge, Rear, Gum Rbr, 700mm, 1-3,
 1-53
 Blade, Sqge, Rear, Gum Rbr, 800mm, 1-3,
 2-51
 Blade, Sqge, Rear, Oil-Rstn, 700mm, 1-53
 Blade, Sqge, Rh, 1-3, 1-35, 2-27, 2-35
 Blade, Sqge, Front, 800mm Linatex Red,
 2-51
 Blade, Sqge, Front, 800mm Linatex, Red,
 2-51
 Blade, Sqge, Front, 800mm, 1-3
 Bladeholder Wldt, Sqge, Disk, Lh, 1-37,
 2-29, 2-37
 Bladeholder Wldt, Sqge, Disk, Rh, 1-37,
 2-29, 2-37
 Block, Centering, 1-51
 Block, Sqge, Adj, 1-51
 Bolt, Shld, .31d X 1.00, .25-20, 1-25
 Bolt, Shld, .50d X 4.25, .38-16, 1-29
 Boot, 90deg .50d .57d X .84, 1-47
 Box, Elec, Connection, 3-8
 Bracket Wldt, Bar, Spray, 800mm [7100],
 2-15
 Bracket Wldt, Bar, Spray, 700mm [7100],
 2-13
 Bracket Wldt, Box Detgt, 2-7
 Bracket Wldt, Guide, Actuator, 1-29
 Bracket Wldt, Light, 2-53, 2-55, 2-57
 Bracket, Bar, Spray, 2-13, 2-15
 Bracket, Brake, Complete, 3-8
 Bracket, Brake, Pivot, 1-21, 1-23
 Bracket, Cable, 1-41
 Bracket, Channel, Mtg, Brake, 1-25
 Bracket, Fan End, 3-3
 Bracket, Fan, 1-41
 Bracket, Filter, 1-39
 Bracket, Guide, Hose, 2-41, 2-47
 Bracket, Keeper, 2-3
 Bracket, Link, Head, Disk, 1-31, 1-33,
 2-23, 2-25, 2-31, 2-33
 Bracket, Mtg, Motor, 2-39, 2-45
 Bracket, Pump, Es, 2-5
 Bracket, Retainer, Spring, 1-5, 1-7
 Bracket, Shield, 2-39, 2-45
 Bracket, Wheel, Sqge, Rear, 1-53, 2-51
 Bracket, 2-7

Brake, Band [Amer], 3-7, 3-8
 Brush Assy, Disk, Scb, 14.0 D, Nyl, 1-5
 Brush Assy, Disk, Scb, 14.0 D, Pyp, 1-5
 Brush Assy, Disk, Scb, 14.0 D, Super Abr,
 1-5
 Brush Assy, Disk, Scb, 16.0 D, Nyl, 1-7
 Brush Assy, Disk, Scb, 16.0 D, Pyp, 1-7
 Brush Assy, Disk, Scb, 16.0 D, Super Abr,
 1-7
 Brush Assy, Motor, 1-31, 1-33
 Brush Kit, Carbon, 3-8
 Brush Kit, Cover, 3-8
 Brush Kit, Motor, 3-8
 Brush Kit,, 3-4
 Brush Mechanism, 3-3
 Brush, Scb, 28l, 18 Sr, Abr, Spl, 1-5
 Brush, Scb, 28l, 18 Sr, Nyl, Spl, 1-5
 Brush, Scb, 28l, 18 Sr, Pyp Grout ,Spl,
 1-3
 Brush, Scb, 28l, 18 Sr, Pyp Grout, Spl, 1-5
 Brush, Scb, 28l, 18 Sr, Pyp, Spl, 1-5
 Brush, Scb, 32l, 18 Sr, Abr, Spl, 1-7
 Brush, Scb, 32l, 18 Sr, Nyl, Spl, 1-7
 Brush, Scb, 32l, 18 Sr, Pyp Grout ,Spl,
 1-3
 Brush, Scb, 32l, 18 Sr, Pyp Grout, Spl, 1-7
 Brush, Scb, 32l, 18 Sr, Pyp, Spl, 1-7
 Brush, 3-5
 Bumper Wldt, V-Mop, 2-3
 Bushing Assy, Flng, 2 Hole, 0.75b, Nyl,
 1-13
 Bushing, Flng, 0.44b 1.25d 0.25l, 1-25
 Bushing, Flng, 0.50b 0.59d 0.38l, 1-31,
 1-33, 1-49, 2-3, 2-23, 2-25, 2-31,
 2-33, 2-41, 2-47
 Bushing, Flng, 0.63b 0.75d 0.38l, 1-51
 Bushing, Sleeve, 0.50b 0.59d 0.38l, Stl,
 1-37, 2-29, 2-37, 2-43, 2-49
 Bushing, Sleeve, 0.62b 0.72d 0.50l, Fgl,
 2-3
 Bushing, Sleeve, 0.63b 0.72d 0.38l, 1-37,
 2-29, 2-37, 2-43, 2-49

C

Cable Assy, Battery, 04ga 2, 175a, 1-47
 Cable Assy, Battery, 06ga 2, 50a/175a,
 2-62
 Cable, Battery, 1-47
 Cable, Water Flow, [Ezrider Hp], 1-45
 Cable, 1-41
 Caliper, Brake, 3-6
 Cam, Adj, Sqge, 1-53, 2-51
 Cap, Axle, Vyl, 02.38d, 1-27
 Cap, Brush Holder, 3-5
 Cap, Plstc, .04 1.38 X 2.30 0.5l, 1-47
 Chain, Coil, Str, #210, 06.9l 05 Link, 1-51
 Chain, Roller #35, .375 Pitch, 1-13
 Channel Wldt, Actuator, Mtg, 1-29
 Channel Wldt, Lift Tool, 1-31, 1-33, 2-25,
 2-33

CROSS REFERENCE

Channel Wldt, Lift, Lh, 2-3
Channel Wldt, Lift, Rh, 2-3
Channel Wldt, Mtg, Spring, 1-25
Channel Wldt, Mtg, Tool, Lift, 1-29
Channel Wldt, Sppt, 1-29
Channel Wldt, Tool, Lift, Cyl [Ezrider],
2-41, 2-47
Channel Wldt, Tool, Lift, Disk [Ezrider],
2-23, 2-31
Channel, .18 0.50 0.03 29.0l, 2-41
Channel, .18 0.50 0.03 33.0l, 2-47
Channel, Brake, 1-23
Channel, Input, Tool, Lift, 1-29
Channel, Sqge, Lower, 1-51
Channel, Sqge, Upper, 1-51
Charger, 36Vdc, 020A 50/60Hz, 2-62
Circuitbreaker, 10.0a, 2-17
Clamp Hose .73-.77 2 Wire Blk, 1-31
Clamp, Cable, Stil, 0.38d X 0.38w, 1h,
2-53, 2-55, 2-57
Clamp, Cable, Stil, 0.56d X 0.38w, 1h, 1-9,
1-19, 2-53, 2-55, 2-57
Clamp, Cable, Stil, 0.63d X 0.75w, 1h, 2-7
Clamp, Cable, Stil, 0.69d X 0.62w, 1h, 1-9,
1-19, 1-43, 1-47, 1-51
Clamp, Cable, Stil, 0.88d X 0.62w, 1h, 1-11
Clamp, Cable, Stil, 0.9x1.8 X 0.88w, 1h,
1-9, 1-17
Clamp, Cable, Stil, 1.00d X 0.75w, 1h, 1-9,
1-17
Clamp, Cable, Stil, 1.50d X 1.00w, 1h, 2-7
Clamp, Hose .40 - .42 2 Wire, 2-7
Clamp, Hose 1-5/16 To 2-1/4 Ss, 1-43
Clamp, Hose, Wormdrive, 0.31-0.88d,
1-33, 1-45, 2-9, 2-11, 2-13, 2-15, 2-23,
2-25, 2-31, 2-33, 2-41, 2-47
Clamp, Hose, Wormdrive, 0.56-1.06d, 2-5
Clamp, Hose, Wormdrive, 1.56-2.50d,
1-41
Clamp, Hose, Wormdrive, 1.62-3.50d,
1-43, 2-5, 2-9
Clip, Hanger, Hose, 1-43
Clip, Hose, Hanger, 1-43
Collar, Locking, 1-49
Comm. Bracket, 3-3
Connector, 2 Conductor, 3-3, 3-4
Connector, 2-Conductor, 3-5
Connector, Anderson, 175a, Gray, 1-47
Contact, Switch, 1-15
Controller, Mach, 1-17
Coupling, Fem, W/Valve, .25 Brb, 2-7
Cover, Elec, Connection, 3-8
Cover, Tank, Trim [Nobles], 1-39
Cover, Terminal, Battery, Pye, 2-60
Cup Holder, 1-11

D

Deflector, Water, 1-3, 2-39, 2-45
Detergent Pkg, 2 Liter, Sgl. (MP), 2-7
Detergent Pkg, 2 Liter, Sgl. (MPD), 2-7
Device, Centering, 1-5, 1-7
Diode, Ele, Plug, 2-19

Disk, Pad Driver, W/ Face, 14d, 1-5
Disk, Pad Driver, W/ Face, 16d, 1-7
Door Wldt, Mtg, Lh, 28 Inch Disk, 1-37,
2-29
Door Wldt, Mtg, Rh, 28 Inch Disk, 1-37,
2-29
Door Wldt, Sqge, Side, Lh, 800mm Disk,
2-37
Door Wldt, Sqge, Side, Rh, 800mm Disk,
2-37
Door, Brush, 2-39, 2-45
Drain Kit, 1-47
Driver Assy, Pad. 14D, 1-5
Driver Assy, Pad. 16D, 1-7
Driver Assy, Pad, 14d, 1-3
Driver Assy, Pad, 16d, 1-3
Duct, Pvc, 0.40 X 0.75 0.40l, 1-19

E

Endbell, Brush End, Motor-Ele, 3-5

F

Fan Assy, Vacuum (See Breakdowns),
1-41
Fan, Vacuum, 3-3
Fan, 3-3
Filter Assy, Air, Molded Ure, 2-7
Filter, Fan, 1-39
Filter, Foam, 2-11, 2-13, 2-15
Filter, Inline, Pf06/Pf06, 80 Mesh, 2-9
Fitting Assy, Cap, 0.045b, Pm04/Bm08,
2-9
Fitting, Brs, E90, Cf03/Pf02, 2-7
Fitting, Brs, E90, Pm04/Bm08, 2-11, 2-13,
2-15
Fitting, Brs, Str, BM06/PM04, 1-47
Fitting, Brs, Str, Pm02/Bm04, 2-7
Fitting, Brs, Str, Pm04/Pf02, 2-9
Fitting, Brs, Tee, Pf04/Pm04/Pf04, 2-9
Fitting, Grease, Str Pm04 .47l, 1-19
Fitting, Plstc, Cap, Pf04, 2-7
Fitting, Plstc, E90, Bm08/Bm08, 2-9, 2-13,
2-15, 2-41, 2-47
Fitting, Plstc, E90, Bm08/Pm04, 2-11,
2-13, 2-15
Fitting, Plstc, E90, Bm08/Pm06, 2-9
Fitting, Plstc, E90, Bm08/Pm12, Nyl, 2-11,
2-13, 2-15
Fitting, Plstc, E90, Bm10/Pm12, 2-5
Fitting, Plstc, E90, Pm12/Pf12, 2-5
Fitting, Plstc, Plug, Pm12, 1-39
Fitting, Plstc, Str, Bm08/Bm08, 1-45, 2-9
Fitting, Plstc, Str, Bm08/Pm06, 2-9, 2-13,
2-15
Fitting, Plstc, Str, Bm08/Pm12, 2-11, 2-13,
2-15
Fitting, Plstc, Str, Bm10/Pm12, 2-5
Fitting, Plstc, Str, Pf12/Pf12, 2-5
Fitting, Plstc, Str, Pm04, Cplg, Male, 2-7
Fitting, Plstc, Str, Pm12/Pm12 03.0l, 2-5

Fitting, Plstc, Str, Spcl, 12pm/10cf, 1-45
Fitting, Plstc, Tee, Bm08/Bm04/Bm08,
2-11, 2-13, 2-15
Fitting, Plstc, Tee, Bm08/Bm08/Bm08,
1-31, 1-33, 2-23, 2-25, 2-31, 2-33,
2-41, 2-47
Fitting, Plstc, Y, Bm08/Bm08/Bm08 Nyl,
2-11
Fitting, Vyl, Y, Formed, 0.5id, 2-9
Flap, Strainrelief, 1-19
Flapper, Valve, 2-5
Frame Wldt, Linkage, Sqge, 1-51
Frame Wldt, Micro Scrubber, 1-9
Frame Wldt, Mop, V, 2-3
Frame Wldt, Sqge, Lh, Cyl, 2-49
Frame Wldt, Sqge, Side, Lh, 2-43
Frame Wldt, Sqge, Side, Rh, 2-43
Frame, Casting, Sqge, 700mm, 1-53
Frame, Casting, Sqge, 800mm, 2-51
Frame, Side Squeegee Rh, 2-49
Fuse, 125 Amp, 58vdc, 1-17
Fuse, Blade, 10a, 58vdc, 1-61, 1-65

G

Gasket Strip, 1-3, 1-15
Gasket, Check, Valve, 2-5
Gasket, Hourmeter, 1-15
Gasket, Shield, 1-3, 2-39, 2-45
Gauge, Battery, 1-15
Gauge, Hourmeter, 12-80 VDC Analog,
1-15
Gearbox, Wheel, 250mm, 36vdc Band
Brake (See Breakdowns), 1-19
Gearbox, Wheel, 250mm, 36vdc Band
Brake, 3-7, 3-8
Gearbox, Wheel, Front, 250mm (See
Breakdowns), 1-19
Gearbox, Wheel, Front, 250mm, 3-6
Grommet, Rbr, 0.62id, F/ 0.9h, .12matl,
2-53, 2-55
Grommet, Rbr, 0.89id, F/ 1.2h, .14matl,
1-25
Grommet, Rbr, 1.31id, F/ 1.6h, .12matl,
1-29, 1-47
Guard Wldt, Light, Revl/Flsh, 2-53, 2-55
Guard, Belt, Drive, Scrbr Head, Lh, 2-39,
2-45
Guard, Belt, Lh, 2-39, 2-45
Guard, Belt, Rh, 2-39, 2-45
Guide Wldt, Linkage, Sqge, 1-49
Guide, Side Sqge, 1-3, 1-37, 2-29, 2-37,
2-43, 2-49

H

Handle, Hood, 1-11
Harness [Ez Rider Hp Fast], 2-19
Harness [Fast Ezriderhp], 2-19
Harness, Main, [Ezrider Hp], 1-65, 1-69
Harness, Pedal, 1-25
Harness, Switch, Seat, 1-11

Harness, Traction, [Ezrider Hp], 1-65, 1-69
 Harness, Wire [Ez Rider Hp], 1-61
 Harness, Wire, Es Pump, 1-61, 1-65, 1-69
 Harness, Wire, Hourmeter, Jumper, 1-61, 1-65, 1-69
 Harness, Wire, Traction Motor, 1-19
 Head Wldt, Disk, 32 Inch Scb, 2-33
 Head Wldt, Scb, Disk, 28 Inch, 1-33, 2-25
 Head Wldt, Scb, Disk, 700mm, 1-31, 2-23
 Head Wldt, Scb, Disk, 800mm, 2-31
 Hinge, .25pin .08 3.5w 13.0l 4/.25slot, 1-39
 Hinge, .25pin .12 3.0w 03.0l 4/0.28slot, 1-11
 Horn, 12-48 Vdc, 1-9
 Hose, .25id X 12" Pvc (C460126), 2-7
 Hose, Afmkt Pvc, Brd 0.50id X 1 Ft (376716), 1-31, 1-33, 2-9, 2-11, 2-13, 2-15, 2-23, 2-25, 2-31, 2-33
 Hose, Afmkt Pvc, Brd 0.50id X 2 Ft (376716), 2-9, 2-11, 2-13, 2-15
 Hose, Afmkt Pvc, Brd 0.62id X 1 Ft (C460117), 2-11
 Hose, Afmkt, Pvc, Clr 0.25id 3ft (C460126), 2-7
 Hose, Afmkt, Pvc, Clr, 0.38ld 1Ft (C080172), 1-47
 Hose, Drain, 1.50id X 32.0l Scrubber, 1-43
 Hose, Drain, 1-43
 Hose, Pvc, Brd, 0.50id (376716), 1-31, 1-33, 2-23, 2-25, 2-31, 2-33
 Hose, Pvc, Brd, 0.50ld, 0.73Od, 15.0L (376716), 1-45
 Hose, Pvc, Brd, 0.50id, 0.73od, 21.0l (376716), 1-45
 Hose, PVC, Brd, 0.62id 0.96od 6.50L (C460117), 2-5
 Hose, Pvc, Clr, 0.50id 0.69od 01.50l, 2-41, 2-47
 Hose, Vacuum, 1-3, 1-39
 Housing Assy, Steering [7100/Ez Rider], 1-13
 Housing Assy, Wheel [7100/Ez Rider], 1-27
 Housing Wldt, Quick-Mop, 2-3
 Housing, Cyl, Mach 700mm, 2-41
 Housing, Cyl, Mach 800mm, 2-47
 Housing, 3-3
 Hub, Drive, Brush, Disk, 0.75B 6T, 1-31, 2-23, 2-31
 Hub, Drive, Brush, Disk, 0.75b 6t, 1-33, 2-25, 2-33

I

Insulation, Acstc, 1-39
 Insulator, Mtg, Fuse, 1-17

J

Joint U, 1-13

K

Key Square 0.25 0.25 01.00 Lg, 3-4
 Key, Replmt, 1-15
 Key, Sq, 0.12 X 0.12, 01.00l, 3-5
 Key, Sq, 0.19 X 0.19, 01.00l, 1-13
 Key, Sq, 0.25 X 0.25, 0.75l, 1-33
 Key, Sq, 0.25 X 0.25, 00.75l, 1-31
 Kit, Brace, 3-5
 Kit, Brush, Cover, 3-6, 3-7
 Kit, Brush, Motor, 3-6, 3-7
 Kit, Brush, 3-5
 Kit, Ci, Alarm, Backup, W/ Bracket, 2-57
 Kit, Ci, Alarm, Backup, W/O Bracket, 2-59
 Kit, Ci, Battery, 36vdc, 244ah Wet, 2-60
 Kit, Ci, Chrgr, 36vdc 025a 60hz 120vac, 2-62
 Kit, Ci, Light, Flsh [Ezhp/7080], 2-55
 Kit, Ci, Light, Revl [Ezhp/7080], 2-53
 Kit, Ci, Scrubhead, 700mm, 1-31, 2-23
 Kit, Ci, Scrubhead, 800mm, 2-31
 Kit, Ci, Sqge Assy, Rear, 700mm[Ez/7080], 1-53
 Kit, Ci, Sqge Assy, Rear, 800mm[Ez/7080], 2-51
 Kit, Ci, Sqge, Linatex, 700mm[Ez/7080], 1-53
 Kit, Ci, Sqge, Linatex, 800mm[Ez/7080], 2-51
 Kit, Ci, V-Mop, 2-3
 Kit, Di, Es [Ezrider Hp/7080], 2-5
 Kit, Motor Bearing, 3-5
 Kit, Repair, Diaphragm, Air Compressor, 2-7
 Kit, Replmt, Actuator, 1-29
 Kit, Sqge, Oil-Rstn, 700mm, 1-3, 1-53
 Kit, Sqge, Oil-Rstn, 800mm [7100], 2-51
 Kit, Sqge, Oil-Rstn, 800mm, 1-3
 Kit, Sqge, Tile, 700mm, 1-3, 1-53
 Kit, Sqge, Tile, 800mm [7100], 2-51
 Kit, Sqge, Tile, 800mm, 1-3
 Kit, Tray, Debris, 28 In, 2-41
 Kit, Tray, Debris, 32 In, 2-47
 Kit, Valve, Check, 2-5
 Kit, Water, Valve, Rebuild, 1-45
 Knob Assy, Rnd, 1.00d 0.50l .25-20 1.5l, 2-51
 Knob, 4-Prong W/.31-18, Insert, 1-53
 Knob, Rnd, . D . L, 1-39
 Knob, Rnd, 0.71d 0.75l 0.25b Plstc, 1-45
 Knob, Star, 2.8 4ear 1.1l .31-18 Plstc, 2-51
 Knob, 1-51, 1-53

L

Label [Nfsi Certification], 1-70
 Label Set, Info/hzrd, 1-70
 Label, [Quick Mop], 2-3
 Label, Attention Fast Users, 2-21
 Label, Fast, 2-21
 Label, Instmt [Ezrider Hp], 1-70
 Label, Model, [Ezrider Hp Fast], 2-21

Label, Std Opertnl, 1-70
 Lamp Assy, Flsh , 2-55
 Lamp Assy, Revl , 2-53
 Lamp, 40vdc, 0.9a, 2-53, 2-55
 Lamp, Bulb, Lamp, Flsh, 2-53
 Lamp, Bulb, Lamp, Strobe, 2-55
 Lamp, Strobe, Amb, 12-80 Vdc , 2-55
 Latch, Door, 2-3
 Latch, 1-35, 1-39, 2-27, 2-35
 Lens, Amber, Light, Flsh, 2-55
 Lens, Amber, Light, Revl, 2-53
 Lens, Blue, Light, Flsh, 2-55
 Lens, Blue, Light, Revl , 2-53
 Lens, Blue, Option, F/Revl/Flsh Light, 2-53, 2-55
 Lens, Lamp, Amb, Strobe/Flasher, 2-53, 2-55
 Lens, Red, Light, Flsh, 2-55
 Lens, Red, Light, Revl, 2-53
 Lens, Red, Option, F/Revl/Flsh Light, 2-53, 2-55
 Lever, Lock, Side Sqge, 1-37, 2-29, 2-37
 Light, Flsh, Amb, 12-48 Vdcl , 2-53
 Light, Panl, 36vdc, 1.1 X 1.0, 1-15
 Link, Balljoint, .38-24, 10.5l, 1-49, 1-51
 Link, Balljoint, M10 X 1.5, 11.0L, 1-31, 1-33, 2-23, 2-25, 2-31, 2-33
 Link, Brake, 1-21, 1-23
 Link, Chain, Roller, #35, 1-13
 Linkage Kit, Brake, Replmt., 1-21
 Linkage Kit, Brake, Replmt, 1-23, 1-25
 Lip, Debris Tray, 28in, 2-41
 Lip, Debris Tray, 32 In, 2-47

M

Manual Pkg, [Ez Rider Hp Ele Na], 2-64
 Manual, Fiche, [Ez Rider Hp Ele], 2-64
 Manual, Oprtr, [Ez Rider Hp Ele Es Na], 2-64
 Manual, Oprtr, [Ez Rider Hp Ele Fr Na], 2-64
 Module, Timer, Detgt, 36vdc, 2-17
 Molding, Trim, .08-.11 10.00, 1-9
 Molding, Trim, .08-.11 19.00, 1-11
 Molding, Trim, Pvc, .08-.11 04.75l, 2-3
 Molding, Trim, Rbr, .13 03.0, 1-33, 2-25
 Mop, Dust, Industrial, 2-3
 Mop, Dust, 2-3
 Motor Assy, Ele, 36Vdc, 0.75Hp (See Breakdowns), 2-39, 2-45
 Motor Assy, Ele, 36Vdc, 0.75Hp, 1700Rpm, 3-5
 Motor, 36 Vdc, 0.8Hp, 320 Rpm, 3-4
 Motor, Ele, 36vdc, 0.50hp, 0320rpm, 1-31, 1-33
 Motor, Ele, 36vdc, 0.80hp, 0320rpm (See Breakdowns), 2-23, 2-25, 2-31, 2-33
 Mount, Cable Tie, 1-39, 2-5, 2-53, 2-55, 2-57
 Muffler, Vacuum Fan, 1-41

CROSS REFERENCE

N

Nut, Hex, Flexlock, .31-18, 1-47
Nut, Hex, Flng, M06 X 1.0, 1-11
Nut, Hex, Flng, M08X1.25, 1-11
Nut, Hex, Jam, .38-24, Lh, 1-31, 2-23, 2-31, 2-41, 2-47
Nut, Hex, Jam, .38-24, 1-31, 2-23, 2-31, 2-41, 2-47
Nut, Hex, Lock, .25-20, NI, 1-25
Nut, Hex, Lock, .31-18, NI, 1-11
Nut, Hex, Lock, .38-16, NI, Thin, 1-29
Nut, Hex, Lock, .38-24, NI, Ss, 1-29, 1-31, 1-49, 1-51, 2-23, 2-31, 2-41, 2-47
Nut, Hex, Lock, .38-24, NI, Thin, 1-49, 1-51
Nut, Hex, Lock, .50-13, NI, Ss, 2-43, 2-49
Nut, Hex, Lock, M 5 X 0.8, NI, 2-17
Nut, Hex, Lock, M 6 X 1.0, NI, 2-17
Nut, Hex, Lock, M 8 X 1.25, NI, Ss, 2-7
Nut, Hex, Lock, M04 X 0.7, NI, 1-25, 2-3
Nut, Hex, Lock, M05 X 0.8, NI, 1-17
Nut, Hex, Lock, M05X0.8, NI, 1-11
Nut, Hex, Lock, M06 X 1.0, NI, Ss, 1-9, 1-19, 1-21, 1-23, 1-31, 1-33, 1-37, 1-41, 1-45, 1-51, 2-23, 2-25, 2-29, 2-31, 2-33, 2-37, 2-41, 2-47
Nut, Hex, Lock, M06 X 1.0, NI, 1-11, 1-15, 1-21, 2-53, 2-55, 2-57, 2-59
Nut, Hex, Lock, M08 X 1.25, NI, Ss, 1-51, 1-53, 2-39, 2-45, 2-51
Nut, Hex, Lock, M08 X 1.25, NI, 1-13, 1-17, 2-3
Nut, Hex, Lock, M10 X 1.5, NL, SS, 1-31, 1-33, 2-23, 2-25, 2-31, 2-33
Nut, Hex, Lock, M10 x 1.5, NI, Ss, 1-29
Nut, Hex, Lock, M10 X 1.5, NI, 1-25, 2-3
Nut, Hex, Lock, M12 X 1.75, NI, 1-13
Nut, Hex, Lock, M5 X 0.8, NI, 2-53, 2-55
Nut, Hex, Sltd, 1.25-12, 1-19
Nut, Hex, Std, M03 X 0.5, 1-15
Nut, Hex, Std, M08 X 1.25, 2-3
Nut, Hex, Std, M10 X 1.5, 2-3
Nut, Isolator, .25-20 Wall Thk .187-.343, 2-53, 2-55, 2-57
Nut, Speed, Clip, .25-20 [.025-.150], 2-51
Nut, Speed, Retainer, .25-20, 1-53
Nut, T, M 10 X1.5 0.623od .516lg, 1-37, 2-29, 2-37, 2-43, 2-49
Nut, T, M8x1.25 X0.498od, 0.516lg, 1-37, 2-29, 2-37, 2-43, 2-49
Nut, Wheel, .44-20 X 60 Angle, 1-27
Nut, 3-3

O

Oil Seal, 3-4

P

Pad, Buff, 14.0d, Red, 1-3, 1-5
Pad, Buff, 16.0d, Red, 1-3, 1-7
Pad, Polish, 16.0d, White, 1-7

Pad, Polish, 14.0d, White, 1-5
Pad, Scrub, 14.0d, Blue, 1-5
Pad, Scrub, 16.0d, Blue, 1-7
Pad, Strip Hd, 14.0d, Black, 1-5
Pad, Strip Hd, 16.0d, Black, 1-5
Pad, Strip, 14.0d, Brown, 1-5
Pad, Strip, 16.0d, Brown, 1-7
Pad, 1-25
Panel, Front, 1-11
Panel, Instmt [Ezrider Hp/7080], 1-15
Panel, Tank, Filler, Plstc, 1-9
Pedal Assy, Foot, 1-25
Pedal Wldt, Brake, 1-25
Pedal, Brake, Lock, 1-25
Perf Kit, Brush, Cyc, 28 In, 1-3
Perf Kit, Brush, Cyl, 32 In, 1-3
Perf Kit, Brush, Disk, 28 In, 1-3
Perf Kit, Brush, Disk, 32 In, 1-3
Pin Kit, Retainer, Snap Rings, 3-8
Pin, Brake, 1-21
Pin, Clevis, 0.19 D X 1.00l, 1-21, 1-23
Pin, Clevis, 0.31 D X 1.00l, 1-37, 2-29, 2-37, 2-43, 2-49
Pin, Clevis, 0.37 D X 0.75l, 1-37, 2-3, 2-29, 2-37, 2-43, 2-49
Pin, Clevis, 0.37 D X 1.50l, 1-25, 1-49
Pin, Clevis, 0.37 D X 1.75l, 1-29
Pin, Clevis, 0.37 D X 2.62l, 1-37, 2-29, 2-37
Pin, Clevis, 0.37 D X 3.00l, 1-53, 2-51
Pin, Clevis, 0.38 D X 1.13l, 1-23
Pin, Clevis, 0.38d X 1.25l, 1-23
Pin, Clevis, 0.50 D X 2.00l, 1-29
Pin, Clevis, 0.50 D X 2.25l, 1-29
Pin, Clevis, 0.50 D X 3.50l, 1-49
Pin, Clevis, 0.50 D X 3.75l, 1-25
Pin, Clevis, 0.50 D X 4.00l, 1-29, 1-31, 1-33, 2-23, 2-25, 2-31, 2-33
Pin, Clevis, 0.50 D X 4.50l, 2-41, 2-47
Pin, Clevis, 0.50 D X 4.75l, 1-35, 2-27, 2-35
Pin, Clevis, 0.50 D X 6.00l, 2-3
Pin, Cotter, .062 X 0.50, 1-21, 1-23
Pin, Cotter, .094 X 0.75, 1-25, 1-49, 1-53, 2-51
Pin, Cotter, .125 X 1.00, 1-23, 1-25, 1-37, 1-49, 2-29, 2-37
Pin, Cotter, .125 X 1.25, 1-35, 2-27, 2-35
Pin, Hair Cotter, 0.38 D .072 Wir, 1-29
Pin, Hair Cotter, 0.43 D .079 Wir, 2-41, 2-47
Pin, Hair Cotter, 0.62 D .120 Wir, 1-29, 1-33, 2-3, 2-25, 2-33
Pin, Hair Cotter, 0.69 D .092 Wir, 1-31, 1-37, 2-23, 2-29, 2-31, 2-37, 2-43, 2-49
Pin, Hair, Cotter, 0.38d .072wir, 1-21, 1-23
Pin, Roll, .090 D 0.25l, .094/.097, 2-39, 2-45
Pivot Wldt, Actuator, 1-49
Plate Wldt, Mtg, Wheel, 1-9
Plate Wldt, Swivel, 1-19
Plate Wldt, Tool, Lift, Cyl, 2-41, 2-47

Plate, Adapter, Wheel, 1-19
Plate, Backup, Sqge, Lh, 1-35, 2-27, 2-35
Plate, Backup, Sqge, Rh, 1-35, 2-27, 2-35
Plate, Latch, 2-3
Plate, Mounting, Tool Lift, Sc, 2-41, 2-47
Plate, Mtg, Light, 1-15
Plate, Orifice, 0.045id, 2-9
Plate, Retainer, Blade, 700mm, 1-53
Plate, Retainer, Blade, 800mm, 2-51
Plate, Seat W/ Labels, Blk, 1-11
Plate, Sppt, Gauge, Battery, 1-15
Plate, Swivel, Bottom, 1-19
Plug Assy, Drive, Brush, 2-39, 2-45
Plug Assy, Idler, Brush, 2-39, 2-45
Plug Expansion 1-1/2"Dia, 1-43
Plug, Drive, Brush, 2-39, 2-45
Plug, Expansion, 2.00 Dia, 1-43
Plug, Idler, Brush, 2-39, 2-45
Plug, Tank, Solution, 1-43
Pump, Air, Ele, 36vdc, 2-7
Pump, Detgt [560s], 2-7
Pump, Soltn, Ele, 36vdc, 2-9
Pump, Solution, Impeller, 36vdc, 2-5

R

Rail, 1-11
Relay, 36vdc, 05a, Spdt N/O [Greenwich], 2-17
Retainer Wldt, Blade, Sqge, 1.2w 41.0l, 2-51
Retainer Wldt, Sqge, 700mm, 1-53
Retainer, Lh, 2-27, 2-35
Retainer, Lh, 1-35
Retainer, Rh, 1-35, 2-27, 2-35
Retainer, Sqge, 1-37, 2-29, 2-37, 2-43, 2-49
Ring, Brush Holder, 3-8
Ring, Mtg, Sqge, 1-53, 2-51
Ring, Retaining, Ext, 0.59d, Basic, 2-39, 2-45
Ring, Retaining, Ext, 1.00d, Basic, 1-27
Ring, Snap, 3-5
Rod Wldt, Prop, 1-11
Rod, Lift, Sqge, 1-49
Rod, Thr, 2 End, .38-24 09.0l Lh/Rh, 1-31, 2-23, 2-31, 2-41, 2-47
Rod-End, .38-24lh Fem 0.38-24stud, 1-31, 2-23, 2-31, 2-41, 2-47
Rod-End, .38-24rh Fem 0.38-24stud, 1-31, 2-23, 2-31, 2-41, 2-47
Roller, Linkage, Head, 1-35, 2-27, 2-35
Rotor, Brake, 14mm, 3-6

S

Screen, 50 Mesh, Ss, 2-9
Screen, Drain, 1-45
Screen, Fan Inlet, 1-41, 3-3
Screen, Fitr, 80 Mesh, 2-9
Screw, Btn, M12 X 1.75 X 25, 10.9 NI, 1-19, 1-29

- Screw, Btn, M6 X 1.0 X 20, Blk, 1-15
 Screw, Btn, M8x 1.25 X 20, Blk, 1-13, 1-17
 Screw, Flat, M06 X 1.0 X 16, 10.9, 1-21
 Screw, Flat, M08-1.25 X 30, Ss, 2-45
 Screw, Flat, M08-1.25x 20, Ss, 1-37, 2-29, 2-37, 2-43, 2-49
 Screw, Flat, M08-1.25x 30, Ss, 2-39
 Screw, Flat, M10 X 1.5 X 20, Ss, NI, 2-39, 2-45
 Screw, Flat, M10 X 1.5 X 20, Ss, 2-43, 2-49
 Screw, Hex, .25-20 X 0.62, Ss, 1-9
 Screw, Hex, .25-20 X 0.75, Ss, 1-31, 1-33
 Screw, Hex, .25-20 X 1.25, Sems, 2-53, 2-55, 2-57
 Screw, Hex, .31-18 X 0.75, Ss, 1-31, 1-33, 2-23, 2-25, 2-31, 2-33
 Screw, Hex, .38-16 X 0.75, Ss, 2-23, 2-25, 2-31, 2-33
 Screw, Hex, .50-13 X 5.00, 5, 2-43, 2-49
 Screw, Hex, M04 X 0.7 X 20, 8.8, 1-25
 Screw, Hex, M06 X 1.0 X 20, Ss, 1-33, 1-37, 2-25
 Screw, Hex, M06 X 1.0 X 12, 8.8, 1-17
 Screw, Hex, M06 X 1.0 X 12, Fmg, 1-25, 2-41, 2-47
 Screw, Hex, M06 X 1.0 X 16, Fmg, 1-19
 Screw, Hex, M06 X 1.0 X 16, Ss, 1-19, 1-39, 2-39, 2-45
 Screw, Hex, M06 X 1.0 X 20, 8.8, 1-11, 2-53, 2-55, 2-57, 2-59
 Screw, Hex, M06 X 1.0 X 20, NI, 1-25
 Screw, Hex, M06 X 1.0 X 20, Ss, 1-9, 1-21, 1-23, 1-31, 1-41, 1-45, 2-23, 2-29, 2-31, 2-33, 2-37
 Screw, Hex, M06 X 1.0 X 25, 8.8, 1-11
 Screw, Hex, M06 X 1.0 X 25, Fmg, 1-19
 Screw, Hex, M06 X 1.0 X 25, Ss, 1-9, 1-35, 1-51, 2-27, 2-35, 2-41, 2-47
 Screw, Hex, M06 X 1.0 X 30, 8.8, 1-17
 Screw, Hex, M06 X 1.0 X 40, Ss, 1-41
 Screw, Hex, M06 X 1.0 X 55, Ss, 1-41
 Screw, Hex, M06 X 1.0 X 80, Ss, 1-41
 Screw, Hex, M08 X 1.25 X 30, Ss, 1-53, 2-51
 Screw, Hex, M08 X 1.25 X 16, Ss, NI, 2-5
 Screw, Hex, M08 X 1.25 X 20, 8.8, 1-9, 1-11
 Screw, Hex, M08 X 1.25 X 20, Ss, NI, 1-11, 1-39, 1-43, 1-49
 Screw, Hex, M08 X 1.25 X 20, Ss, 1-9, 1-39, 1-41, 1-43, 1-49, 1-51, 2-7, 2-39, 2-45
 Screw, Hex, M08 X 1.25 X 25, 8.8, 1-29
 Screw, Hex, M08 X 1.25 X 25, Fmg, 2-39, 2-41, 2-43, 2-45, 2-47, 2-49
 Screw, Hex, M08 X 1.25 X 25, Ss, 1-47, 1-51
 Screw, Hex, M08 X 1.25 X 30, Ss, 2-41, 2-47
 Screw, Hex, M08 X 1.25 X 35, Ss Fl, 2-39, 2-45
 Screw, Hex, M08 X 1.25 X 50, Ss, 1-39, 1-43
 Screw, Hex, M08 X 1.25 X 55, Ss, 1-19
 Screw, Hex, M08 X 1.25 X 60, 8.8, 1-9
 Screw, Hex, M08 X 1.25 X 60, Fl, 2-3
 Screw, Hex, M08 X 1.25 X 60, Ss, 1-21
 Screw, Hex, M08 X 1.25 X 70, Ss, 1-53, 2-51
 Screw, Hex, M10 X 1.5 X 20, Ss, 1-37
 Screw, Hex, M10 X 1.5 X 20, SS, NL, 1-31, 1-33, 2-23, 2-25, 2-31, 2-33
 Screw, Hex, M10 X 1.5 X 20, Ss, 2-29, 2-37
 Screw, Hex, M10 X 1.5 X 35, 8.8, 1-13, 1-25
 Screw, Hex, M10 X 1.5 X 35, Ss, 2-3
 Screw, Hex, M10 X 1.5 X 45, 8.8, 1-19
 Screw, Hex, M10 X 1.5 X 50, 8.8, 1-19
 Screw, Hex, M10 X 1.5 X 90, Fl, 2-3
 Screw, Hex, M5 X 0.8 X 10, Fmg, 1-25
 Screw, Hex, M5 X 0.8 X 16, 8.8, 2-53, 2-55
 Screw, Hex, M6 X 1.0 X 12, Ss, NI, 2-13, 2-15
 Screw, Hex, M8 X 1.25 X 20, Ss, NI, 2-13, 2-15
 Screw, Hex, M8 X 1.25 X 20, Ss, 2-7
 Screw, Hex, M8 X 1.25 X 25, Ss, 2-7
 Screw, Hex, M8 X 1.25 X 60, 8.8, 1-23
 Screw, Pan, .31-18 X 0.75, 2, 1-11
 Screw, Pan, #12-16 X 0.50, F/Plstc, 1-9, 2-53, 2-55, 2-57
 Screw, Pan, #12-16 X 0.50, F/Plstc, 1-15
 Screw, Pan, M 5 X 0.8 X 20, 4.8, 1-11
 Screw, Pan, M 6 X 1.0 X 12, Ss, 1-11
 Screw, Pan, M 6 X 1.0 X 20, 4.8, 1-11
 Screw, Pan, M03 X 0.5 X 12, 4.8, 1-15
 Screw, Pan, M04 X 0.7 X 10, Ss, 2-3
 Screw, Pan, M04 X 0.7 X 20, Ss, 2-3
 Screw, Pan, M04 X 0.7 X 35, Ss, 1-5, 1-7
 Screw, Pan, M04x0.7 X 8, Ss, 1-39
 Screw, Pan, M05 X 0.8 X 35, 4.8, 1-17
 Screw, Pan, M06 X 1.0 X 40, 4.8, 1-47
 Screw, Pan, M08 X 1.25 X 20, 4.8, 1-15
 Screw, Pan, M4 X 0.7 X 16, 4.8, 2-7
 Screw, Pan, M5 X 0.8 X 10, 4.8, 2-11, 2-13, 2-15, 2-17
 Screw, Pan, M6 X 1.0 X 35, 4.8, 2-17
 Screw, Set, .31-18 X 0.38, NI, 1-13
 Screw, Set, #08-32 X 0.25, NI, 2-39, 2-45
 Screw, Wheel Mount, 3-8
 Seal, Fan, 1-3, 1-41
 Seal, Felt, .19th, 4.3d 04.0h, 1-19
 Seal, Foam, 1-15
 Seal, Rbr, Fan, 5.6d 2.0b 1.37l, 3-3
 Seal, Ring, 2-39, 2-45, 3-6, 3-7
 Seal, Tank, Recvy, 1-3, 1-39
 Seal, Tank, Soltn, 1-3, 1-39
 Seal, 3-5
 Seat, Michigan, Model V-1500, 1-11
 Sensor, Level, Liquid [Magnetic], 1-39, 2-5
 Sensor, Pedal Position, 1-25
 Shaft, Drive Plug, 2-39, 2-45
 Shaft, Idler Plug, 2-39, 2-45
 Shaft, Steering, Upper, Mach, .75d 24.1l, 1-13
 Shaft, W/ Sprocket, Steering, 1-13
 Shell, 3-3
 Shroud, Front, Trim, 1-9
 Shunt, 2-33
 Skirt, Front, Scb, Disk, 28 Inch, 1-3, 1-31, 1-33, 2-23, 2-25
 Skirt, Front, Scb, Disk, 32 Inch, 1-3, 2-31, 2-33
 Skirt, Rear, Scb, Disk, 28 Inch, 1-3, 1-31, 1-33, 2-23, 2-25
 Skirt, Rear, Scb, Disk, 32 Inch, 1-3, 2-31, 2-33
 Skirt, 2-41, 2-47
 Sleeve, .50id X .62od X 1.31l, 1-29
 Sleeve, Fuse, Controller, 1-17
 Sleeve, Hose, Drain, 1.5id Copp, 1-43
 Sleeve, P/M, 0.437d 0.318b 1.15l 430ss, 1-9, 1-39, 1-43
 Sleeve, P/M, 0.496d 0.318b 0.50l 430ss, 1-53, 2-51
 Sleeve, 1-41
 Spacer, .41b .63d .13l, Ss 430pm, 1-49
 Spacer, .41b X .63od X .38l, 1-19, 1-47, 1-51
 Spacer, Aluminum, 3-8
 Spacer, Battery 1.50x4.75x7.5, 2-60, 2-61
 Spacer, Battery, 2-61
 Spacer, Foam, 2-60
 Spacer, Spring, 2-3
 Spacer, 2-3, 3-3
 Spring Kit, Pedal, Foot, Replmt, 1-25
 Spring, Centering, 1-51
 Spring, Cmpr, .37id X Flat Wir 1.0l, 1-25
 Spring, Cmpr, 0.84od .11wir 2.0l, 1-29
 Spring, Cmpr, 0.98od .14wir 2.5l, 1-29
 Spring, Extn, 0.38od X 0.04wir, 2.3l, 1-25
 Spring, Extn, 0.50od X 0.04wir, 3.0l, 1-25
 Spring, Extn, 0.50od X 0.05wir, 8.0l, 1-19
 Spring, Extn, 0.62od X 0.08wir, 3.0l, 1-37, 2-3, 2-29, 2-37, 2-43, 2-49
 Spring, Extn, 0.75od X 0.09wir, 2.5l, 2-3
 Spring, Extn, 1.00od X 0.12wir, 5.0l, 1-51
 Spring, Flt, Door, Scrbr Head, 2-39, 2-45
 Spring, Tors, 2.36id .18wir 07.5coil, 2-3
 Spring, Wir, 0.08d, Brake, Parking, 1-25
 Spring, Wir, 0.16d, Brush Retaining, 1-5, 1-7
 Spring, 3-3
 Sprocket, Steering, Drive, 1-19
 Sprocket, Timing, 22tooth, 0.50b, [Gt/2], 2-39, 2-45
 Squeegee Assy, Side [Linatex], 1-37, 2-29, 2-37
 Squeegee Assy, Side, 2-43
 Stationary Fan, 3-3
 Strainer, Soltn, 20mesh Cyl 4.0d 8.0l, 2-5
 Strap Drain Hose 170/443/E17, 1-43
 Strap, Hose, Drain, 1-43
 Strip, Cover, Shroud, Front, 1-9
 Strip, Debris Tray, 2-41, 2-47

CROSS REFERENCE

Strip, Retainer, Skirt, Front, 28 Inch, 1-31, 1-33, 2-23, 2-25
Strip, Retainer, Skirt, Front, 32 Inch, 2-31, 2-33
Strip, Retainer, Skirt, Rear, 28 Inch, 1-31, 1-33, 2-23, 2-25
Strip, Retainer, Skirt, Rear, 32 Inch, 2-31, 2-33
Strip, 1-39, 1-43
Support Wldt, Seat, 1-11
Switch, Key, 1-15
Switch, Press, 10psi, Spst, 2-9
Switch, Push, 12vdc 80a Spst No, 1-15
Switch, Rocker, 36vdc 05a Dpst On/N/On, 2-17
Switch, Rocker, 36vdc, 05a Dpst On/Off/On, 1-15
Switch, Rocker, Dpst, 1-15
Switch, Rocker, Hole Plug, 1-15
Switch, Seat, Nc, 1-11
Switch, 1-15

T

Tank, Recvy, W/ Es, Afmkt [Ezrider Hp], 1-39
Tank, Recvy, W/O Es, Afmkt [Ezrider Hp], 1-39
Tank, Soltn, Trim [Ezrider Hp], 1-43
Tape, [Protective], .0080th, 1.0w, 5.0l, 1-37, 2-29, 2-37
Terminal Female Metri-Pack, 3-4
Terminal, Female, 3-3, 3-5
Tie, Cable, Nyl 07.3L .19W 1.8 Max D, 1-39
Tie, Cable, Nyl, 07.3L .19W 1.8 Max D, 2-5
Tie, Cable, Nyl, 11.4l .19w 3.0 Max D, 2-53, 2-55, 2-57
Tie, Cable, Nyl, 14.5L .30W 4.0 Max D, 1-31, 2-23, 2-31
Tie, Cable, Nyl, 14.5l .30w 4.0 Max D, 1-33, 2-25, 2-33, 2-39, 2-45
Tire Assy, Solid, 12.0 X 3.5 3.5Bc/3Bolt, 2-63
Tire Assy, Solid, 12.3x3.5 3.5bc/3bolt, 1-27
Tire, Solid, 250mm x 90mm Grey Pyu, 3-6
Tire, Solid, 250mmx90mm Gray, 3-8
Tire, Solid, 250mmx90mm Grey Pyu, 3-7
Tire, Solid, 250mmx90mm Red, 3-8
Tool, Removal, Shaft, F/222176, 2-39, 2-45
Tray, Battery, Lh, 1-47
Tray, Battery, Rh, 1-47
Tray, Debris, 32 Inch, 2-47
Tray, 2-41
Tread, Non-Skid, 02.2w 11.5l, 1-25
Tread, Non-Skid, 14.0 9.6, 1-9
Tube Assy, Bar, Spray 700mm [7100], 2-13
Tube Assy, Spray, Cyl 800mm [7100], 2-15
Tube, Pvc, Shc80, Clear, 4.0l, 2-11, 2-13, 2-15

V

Vacuum Fan, 3-3
Valve, Check, 2 Gpm 2 Psi Bm04/Bm04, 2-7
Valve, Check, 2-5
Valve, Solution, 1-45
Valve, Water, Sol , 36vdc 02pf, 2-11, 2-13, 2-15
Video, Operator, Vhs [Ezrider Hp], 2-64

W

Washer, 0.26b 0.72d .06, Nyl, 1-37
Washer, 0.31b 0.88d .12, Rbr, 1-51
Washer, 0.38b 1.25d .12, Neo, 2-51
Washer, 0.38b 0.88d .12, Stil, Pl, 1-11
Washer, 0.38b 1.25d .12, Neo, 1-53
Washer, 0.40b 1.12d .12, Stil, Pl, 1-9, 1-11, 1-39, 1-43
Washer, 0.47b 1.19d .03, Nyl, 3-5
Washer, 0.53b 1.88d .12, Stil, Pl, 2-51
Washer, 0.53b 1.88d .12, Stil, Pl, 1-53
Washer, Belleville, .31, 1-31, 1-33, 2-23, 2-25, 2-31, 2-33
Washer, Belleville, .38, 1-13
Washer, Flat, .25 Sae (Non-FaST Models Only), 1-17
Washer, Flat, .25 Sae, 1-11, 1-15, 1-17
Washer, Flat, .25 Ss, 1-35, 1-37, 1-39, 1-45, 2-23, 2-27, 2-29, 2-31, 2-35, 2-37
Washer, Flat, .25 Std, 1-11, 1-13, 1-17, 1-19, 1-29, 1-39, 1-43
Washer, Flat, .31 Ss, 1-15, 1-39, 1-43, 2-5, 2-51
Washer, Flat, .34b .75d .12, Viton, 2-9
Washer, Flat, .50 Sae, 1-29
Washer, Flat, #06 Ss, 1-39
Washer, Flat, #06, 2-7
Washer, Flat, #08, 1-25
Washer, Flat, #10 Sae, 1-11, 1-17, 2-11, 2-13, 2-15
Washer, Flat, #10, 2-53, 2-55
Washer, Flat, 0.25 Fender, 1-11, 1-19
Washer, Flat, 0.25 Ss, 2-13, 2-15
Washer, Flat, 0.25 Std, 2-17
Washer, Flat, 0.26b 0.72d .06, Nyl, 2-29, 2-37
Washer, Flat, 0.31 Ss, 2-7, 2-13, 2-15
Washer, Flat, 0.35b 0.75d .04 Ss, 1-53, 2-51
Washer, Flat, 0.44b 1.00 .08, Ss, 1-29, 1-31, 1-33, 1-37, 1-51, 2-3, 2-23, 2-25, 2-29, 2-31, 2-33, 2-37, 2-41, 2-47
Washer, Flat, 0.51b 0.94d .06, Nyl, 1-49
Washer, Flat, M12, 13x24x2.5ss, 2-43, 2-49
Washer, Flt, .25 Sae, 1-9, 1-11, 1-19, 1-25, 2-53, 2-55, 2-57, 2-59
Washer, Flt, .25 Ss, 1-9, 1-33, 1-41, 1-51, 2-25, 2-33, 2-39, 2-41, 2-45, 2-47

Washer, Flt, .31 Ss, 1-9, 1-19, 1-21, 1-23, 1-39, 1-41, 1-43, 1-47, 1-49, 1-51, 1-53, 2-7, 2-39, 2-41, 2-45, 2-47
Washer, Flt, .31 Std, 1-11, 2-3, 2-53, 2-55, 2-57
Washer, Flt, .38 Std, 1-25, 2-3
Washer, Flt, .50 Sae, 1-25, 1-29, 1-31, 1-33, 2-23, 2-25, 2-31, 2-33, 2-41, 2-47
Washer, Flt, .50 Ss, 1-49
Washer, Flt, .50 Std, 1-13
Washer, Flt, #10, 1-25, 2-17
Washer, Flt, 0.25 Ss, 1-33
Washer, Flt, 25 Ss, 1-31
Washer, Lock, Int, .25, 1-17
Washer, Lock, Int, #04, 1-15
Washer, Lock, Int, #10, 2-11, 2-13, 2-15
Washer, Neo., 3-3
Washer, Spring, 3-5
Washer, Switch, Key, 1-15
Washer, Thrust, 0.61b 1.25d .06, Fgl, 1-37, 2-3, 2-29, 2-37, 2-43, 2-49
Washer, Thrust, 1-19
Washer, 1-19, 1-23
Weight, Soltn Hose, 1-45
Wheel Assy, Sqge, 1-3, 1-53, 2-51
Wheel, 4.0d 0.87w 0.44b, 1-9, 1-39, 1-43
Wheel, Bmpr, 80d X 25w, Non-marking, 1-3, 1-53, 2-51
Wheel, Steering, 14.0d, Taper Bore, 1-13
Wire Assy, Jumper Reverse, 2-39, 2-45
Wire, 04ga 08.0l Blk .34ring / .34ring, 1-47
Wire, 04ga 12.0l Blk .34ring / .34ring, 1-47

SECTION 4

CONTENTS	PAGE
PART NUMBER TO PAGE NUMBER CROSS REFERENCE LIST	4-2
PART DESCRIPTION TO PAGE NUMBER CROSS REFERENCE LIST	4-7

CROSS REFERENCE

PART NUMBER TO PAGE NUMBER CROSS REFERENCE LIST

Part Number	Page Number	Part Number	Page Number	Part Number	Page Number
00912	1-13	08175	1-35, 2-27, 2-35	1005770	1-45
00926	1-31, 1-33	08182	1-23, 1-25, 1-37, 1-49, 2-29, 2-37	1005866	2-9
00928	3-4	08708	1-11, 1-15, 1-21, 2-17, 2-53, 2-55, 2-57, 2-59	1006123	1-31, 1-33, 2-23, 2-25, 2-31, 2-33
00954	3-5	08709	1-13, 1-17, 2-3	1006204	2-7
01516	2-39, 2-45	08711	1-13	1006206	2-7
01684	1-9, 1-31, 1-33, 1-35, 1-37, 1-39, 1-41, 1-45, 1-51, 2-13, 2-15, 2-23, 2-25, 2-27, 2-29, 2-31, 2-33, 2-35, 2-37, 2-39, 2-41, 2-45, 2-47	08712	1-9, 1-19, 1-21, 1-23, 1-31, 1-33, 1-37, 1-41, 1-45, 1-51, 2-23, 2-25, 2-29, 2-31, 2-33, 2-37, 2-41, 2-47	1006415	2-7
01685	1-9, 1-15, 1-19, 1-21, 1-23, 1-39, 1-41, 1-43, 1-47, 1-49, 1-51, 1-53, 2-5, 2-7, 2-13, 2-15, 2-39, 2-41, 2-45, 2-47, 2-51	08713	1-51, 1-53, 2-7, 2-39, 2-45, 2-51	1006447	2-9
01686	1-29, 1-31, 1-33, 1-37, 1-51, 2-3, 2-23, 2-25, 2-29, 2-31, 2-33, 2-37, 2-41, 2-47	08714	1-29, 1-31, 1-33, 2-23, 2-25, 2-31, 2-33	1006723	1-25
01697	1-9	08716	1-9, 1-21, 1-23, 1-31, 1-33, 1-37, 1-41, 1-45, 2-23, 2-25, 2-29, 2-31, 2-33, 2-37	1007541	1-19, 3-7
01754	1-15	09005	1-27	1007845	1-9
01837	3-3	09007	1-9, 1-35, 1-51, 2-27, 2-35, 2-41, 2-47	1008211	2-7
01856	3-3	09010	1-47, 1-51, 2-7	1008388	1-49
01971	3-3	09011	1-53, 2-41, 2-47, 2-51	1008969	1-35, 2-27, 2-35
02076	1-47	09023	2-39, 2-45	1008981	1-35, 2-27, 2-35
02185	1-49, 1-51	09062	1-21	1009603	2-11, 2-13, 2-15
02850	1-25, 2-3	09146	1-15	1010506	2-39, 2-45
02931	2-43, 2-49	09164	1-11	1010560	1-3, 1-53, 2-51
02942	1-29, 1-33, 2-3, 2-25, 2-33	09198	1-5, 1-7	1010668	2-11
02991	1-31, 1-33, 2-23, 2-25, 2-31, 2-33	09228	1-25	1010684	2-11, 2-13, 2-15
02994	2-23, 2-25, 2-31, 2-33	09244	2-53, 2-55	1010713	2-11, 2-13, 2-15
04051	1-29, 1-47	09258	1-47	1010836	2-11, 2-13, 2-15
04414	1-53, 2-51	09291	1-37, 2-29, 2-37	1011403	1-31, 1-33, 2-9, 2-11, 2-13, 2-15, 2-23, 2-25, 2-31, 2-33
05134	2-5	09570	1-9, 1-17	1011521	2-9, 2-11, 2-13, 2-15
05724	1-7	09740	1-9, 1-15, 1-39, 1-41, 1-43, 1-49, 1-51, 2-7, 2-39, 2-45	1012831	2-7
05726	1-7	09767	1-53, 2-51	1013079	2-15
06474A	1-49	1001268	1-35, 2-27, 2-35	1013789	2-7
06549	1-11, 1-17, 2-17, 2-53, 2-55	1001290	1-3, 1-35, 2-27, 2-35	1013902	2-7
06927	2-7	1001959	1-19	1013935	2-9
06932	2-11, 2-13, 2-15, 2-17	1002522	1-23	1014011	2-9
06934	1-11	1002536	1-23	1014082	2-7
06937	1-17	1002537	1-23	1014140	2-21
06943	1-11, 2-53, 2-55, 2-57, 2-59	1002672	1-17	1014436	2-9
06944	1-11	1002789	2-11, 2-13, 2-15	1014673	2-13, 2-15
06945	1-17	1005086	2-11, 2-13, 2-15	1014675	2-9
06957	1-9, 1-21, 1-23	1005199	2-17	1014791	2-13
06962	1-19	1005255	2-7	1014929	1-47
07259	1-19	1005302	2-9	1014957	2-15
07449	2-3	1005304	2-9	1014993	2-13
07790	1-11	1005416	2-21	1015012	1-70
07791	1-11	1005435	2-7	1015033	2-11
08170	1-21, 1-23	1005469	1-53, 2-51	1015365	2-7
		1005508	2-9	1015950	1-31, 2-23
		1005552	2-11, 2-13, 2-15	1015951	2-31
		1005650	1-17	1015951	2-31
				1016045	1-51
				1016832	1-17
				1017015	2-7
				1017022	2-7
				1017248	2-53
				1017250	2-55
				1017439	1-23
				1017440	1-23
				1019764	1-25
				1022253	2-47
				1022254	2-41
				1026017	1-23

CROSS REFERENCE

Part Number	Page Number	Part Number	Page Number	Part Number	Page Number
1026028	1-23	20536-2	3-5	222877	3-5
1027798	2-53, 2-55	21120	2-41, 2-47	22297	1-41
1027800	2-53, 2-55	222055	1-35, 2-27, 2-35	22298	1-19
1029217	3-8	222159	1-19	223061	1-13
1029218	3-8	222167	2-41	223065	1-13
1029220	3-8	222176	2-39, 2-45	223072	1-13
1029223	3-8	222177	2-39, 2-45	223073	1-13
1029225	3-8	222184	2-39, 2-45	223075	1-13
1029226	3-8	222196	1-29, 1-31, 1-33, 2-23, 2-25, 2-31, 2-33	223080	1-11
1029227	3-8	222197	1-35, 2-27, 2-35	223153	1-19
1029228	3-8	222201	1-3	223154	1-19
1030477	3-8	222203	2-41	223157	1-19
10573	2-5	222204	2-47	223159	1-19
10632-2	2-53, 2-55	222209	2-39, 2-45	223160	1-19
10632	1-25	222233	1-51	223161	1-19
10925	3-3, 3-4, 3-5	222236	1-51	223198	1-25
10926	3-3	222244	1-53, 2-51	223304	2-49
10959	1-31, 1-33, 2-23, 2-25, 2-31, 2-33	222268	1-53, 2-51	223330	1-11
11109	1-27	222290	2-19	223351	3-4
11211	1-29	222304	1-3, 1-5	223352	3-4
11635	2-13, 2-15	222305	1-5	223355	1-47
12273	1-11, 1-39, 1-43, 1-49, 2-13, 2-15	222306	1-5	223356	1-47
12274	1-25	222307	1-3, 1-7	223358	2-23, 2-25, 2-31, 2-33, 3-4
12323	2-3	222308	1-7	223361	1-47
13248	1-9, 1-11, 1-39, 1-43	222309	1-7	223412	2-41, 2-47
13534	1-27	222320	1-5	223413	2-49
140027	1-53, 2-51	222321	1-5	223517	1-29
140308	1-43	222322	1-5	223518	1-29
140608	1-23	222324	1-5	223560	2-39, 2-45
14799	1-13	222325	1-3, 1-5	223561	2-39, 2-45
14838	1-5, 1-7	222326	1-5	223563	2-39, 2-45
150100	2-9	222327	1-5	223564	2-39, 2-45
15047	1-37, 2-3, 2-29, 2-37, 2-43, 2-49	222374	1-45	223566	2-39, 2-45
150516	1-47	222460	1-53, 2-51	223568	1-3, 2-39, 2-45
150525	2-7	222497	1-41	223569	1-3, 2-39, 2-45
15539	1-5, 1-7	222504	1-19	223599	1-11
15648	1-31, 1-33, 1-49, 2-3, 2-23, 2-25, 2-31, 2-33, 2-41, 2-47	222523	2-41, 2-47	223621	1-25
15675	2-7	222606	3-4	223639	2-60, 2-61
15678	1-19, 1-39, 2-39, 2-45	222618	3-4	223645	1-33, 2-25
16213	1-25	222625	3-5	223679	2-62
16236	1-37, 2-29, 2-37	222627	3-5	223691	2-62
16930	1-19	222629	3-5	22892	1-47
16931	1-9, 1-11	222635	3-5	23191	1-53, 2-51
16951	2-53, 2-55, 2-57	222637	3-5	24299	1-5, 1-7
17188	1-43, 2-5, 2-9	222669	2-41, 2-47	24537	3-4, 3-5
17461	1-29	222670	2-41, 2-47	24672	1-31, 1-33
18628	3-3	222683	1-15	24989	1-19
19064	2-7	222691	2-62	25537	1-11
19065	1-25	222742	1-45	25709	1-37, 2-29, 2-37, 2-43, 2-49
19066	1-25, 2-17, 2-53, 2-55	222751	2-39, 2-45	25735	1-51
19324	1-11, 1-17, 2-11, 2-13, 2-15	222752	2-39, 2-45	26395-1	1-9, 1-19, 2-53, 2-55, 2-57
19588	2-43, 2-49	222793	1-43	26395-2	2-53, 2-55, 2-57
20171	1-31, 2-23, 2-31, 2-41, 2-47	222794	1-53, 2-51	29558	1-25, 1-49
		222818	2-39, 2-45	30241	1-7
		222820	2-39, 2-45	32483	1-9, 1-11, 1-15, 1-17, 1-19, 1-25, 2-53, 2-55, 2-57, 2-59
		222822	1-39, 2-5		
		222824	2-41		
		222825	2-47		
		222836	2-33		

CROSS REFERENCE

Part Number	Page Number	Part Number	Page Number	Part Number	Page Number
32486	1-25, 1-29, 1-31, 1-33, 2-23, 2-25, 2-31, 2-33, 2-41, 2-47	375411	1-11	390800	1-9
32490	1-11, 1-13, 1-17, 1-19, 1-29, 1-39, 1-43, 2-17	377333	2-39, 2-45	390822	1-39, 1-43
32491	1-11, 2-3, 2-53, 2-55, 2-57	377364	1-33, 2-25, 2-33	390825	2-60
32492	1-23, 1-25, 2-3	377374	1-31, 2-23, 2-31	390829	2-60
32493	1-13	377393	1-47	390841	2-62
32980	2-11, 2-13, 2-15	377411	1-21, 1-23, 1-25	390845	2-62
32982	1-17	377433	1-15	390848	1-19
32983	1-11	377505	2-39, 2-45	390849	1-31, 1-33
330820	2-64	37912	3-3	390851	1-19, 3-6
330821	2-64	379202	2-39, 2-45	390855	1-19
33925	2-43, 2-49	37929	3-3	390856	1-21
33930	1-41	380587	2-43, 2-49	390857	1-21
33944	2-17	382264	1-11	390879	1-19, 1-47, 1-51
360369	1-11	383721	2-17	390880	1-49
360370	1-11	384265	2-3	390882	1-3, 1-39
360930	1-41	384287	2-3	390883	1-3, 1-39
360973	1-9, 1-15, 2-53, 2-55, 2-57	384418	2-3	390892	1-21
361074	1-15	384419	2-3	390893	1-21
361339	1-19	385665	2-5	390895	1-21
36191	1-21, 1-23	385728	1-25	390905	1-27
363087	1-25	385729	1-25	390915	2-55
363468	2-39, 2-45	385766	2-63	390916	2-53
363503	1-11	386326	1-39	390920	2-51
363976	2-3	39005	1-25, 1-49, 1-53, 2-51	390922	1-3, 2-51
363981	1-25	39019	1-37, 2-3, 2-29, 2-37, 2-43, 2-49	390923	1-3, 2-51
364631	1-45, 2-9	390633	1-3, 1-31, 1-33, 2-23, 2-25	390924	2-51
365095	2-5	390634	1-3, 1-31, 1-33, 2-23, 2-25	390933	1-31, 1-33, 2-23, 2-25, 2-31, 2-33
36643	1-29	390635	1-31, 1-33, 2-23, 2-25	390934	1-3, 2-51
369345	1-27	390636	1-31, 1-33, 2-23, 2-25	390936	1-3, 1-53
369349	2-57, 2-59	390641	2-41	390940	1-53
369460	2-39, 2-45	390650	1-3, 2-31, 2-33	390942	1-3, 1-53
369865	2-5	390651	1-3, 2-31, 2-33	390943	1-3, 1-53
370091	1-5	390652	2-31, 2-33	390944	1-53
370092	1-7	390653	2-31, 2-33	390946	1-3, 1-39
370095	1-5, 1-7	390665	1-29	390965	1-49
370100	1-53, 2-51	390666	1-31, 2-23, 2-31, 2-41, 2-47	390970	1-49
372874	3-8	390667	2-47	390975	1-51
374004	3-5	390670	1-53	390982	1-53, 2-51
374006	2-41	390671	2-51	390988	1-37, 2-29, 2-37
374007	2-47	390677	1-41	390989	1-49
374041	1-5	390694	1-11	390994	1-43
374042	1-7	390696	1-9	390996	2-39, 2-45
374175	2-39, 2-45, 3-5	390702	1-37, 2-29	390997	1-37, 2-29, 2-37
374176	3-5	390707	1-37, 2-29, 2-37	391051	2-3
374225	1-25	390710	1-37, 2-29	391115	2-5
374299	1-19	390720	1-37, 2-29, 2-37	391176	2-43, 2-49
374333	1-3	390730	2-33	391179	1-37, 2-29, 2-37
374334	1-3	390734	2-37	391257	2-3
374335	1-3	390736	2-37	391259	3-8
374336	1-3	390741	1-33, 2-25, 2-33	391261	3-6, 3-7, 3-8
374346	1-19, 3-8	390764	2-61	391262	3-6, 3-7
375177	3-5	390767	2-62	391262AM	3-8
375178	3-5	390769	1-11	391263	3-6, 3-7
375179	3-5	390773	1-3, 1-53, 2-51	391264	3-6, 3-7, 3-8
375195	2-39, 2-45	390775	1-19	391265	3-6, 3-7, 3-8
		390785	1-19	391266	3-6, 3-7
		390788	1-13	391271	3-6
				391274	3-6
				391287	2-3

CROSS REFERENCE

Part Number	Page Number	Part Number	Page Number	Part Number	Page Number
391296	1-41	392874	1-45	393143	1-70
391297	1-70	392877	1-15	393149	1-61, 1-65
391300	1-19	392878	1-43	393150	1-45
391304	1-9	392881	1-49, 1-51	393151	1-29
391309	1-41	392882	1-31, 1-33, 2-23, 2-25, 2-31, 2-33	393159	1-61, 1-65, 1-69
391317	1-43	392887	1-29	393160	1-61, 1-65, 1-69
391318	1-43	392891	1-61	393161	1-65, 1-69
391319	1-43	392892	1-19	393162	1-65, 1-69
391327	2-43	392894	1-15	393164	1-31, 2-23
391328	2-43	392895	1-17	393165	2-31
391330	2-47	392896	1-15	393170	1-15
391334	1-3, 2-43	392897	1-15	39658	1-15
391338	1-39	392899	1-51	397644	2-53, 2-55, 2-57
391341	1-39	392902	1-31, 2-23, 2-31	397889	1-15, 2-17
391343	1-3, 1-41, 3-3	392917	1-70	397914	1-3, 1-5
391345	1-37, 2-29, 2-37, 2-43, 2-49	392926	1-9	397916	1-3, 1-7
391346	1-37, 2-29, 2-37, 2-43, 2-49	392933	2-41, 2-47	397974	1-5
391350	1-41, 3-3	392934	1-51	397976	1-7
391351	1-39	392937	1-9	398501	1-15
391362	2-60, 2-61	392941	1-43	398511	3-3
391368	1-41	392943	1-9	398512	3-3
391370	1-33, 2-25	392944	1-39	398513	3-3
391372	1-39	392946	2-5	398514	3-3
391377	1-3, 1-53	392948	1-39	398515	3-3
391378	1-3, 1-53	392953	1-39	398516	3-3
391379	1-3, 2-51	392954	1-39	398517	3-3
391380	1-3, 2-51	392955	1-45	398518	3-3
391381	1-13	392962	2-53, 2-55, 2-57	398519	3-3
391382	1-27	392963	1-43	398521	3-3
391383	1-3, 2-51	392966	1-25	398526	2-17
391384	1-3, 1-53	392967	1-29	40678-1	1-11
391385	1-3, 2-51	392968	1-21	40758	1-51
391386	1-3, 1-53	392980	1-53	41178	1-11, 1-19
391401	1-13	392981	2-51	41186	1-31, 1-33, 2-23, 2-25, 2-31, 2-33
391403	1-39	392988	1-53	41187	1-13
391434	1-41	392989	2-51	41360	2-39, 2-45
391449	2-7	393016	2-41, 2-47	41430	1-25, 2-3
391451	2-21	393017	2-43, 2-49	41578	1-39
391463	3-6, 3-7, 3-8	393018	2-43, 2-49	41619	1-49
391465	3-7, 3-8	393023	1-29	44078	1-15
391467	3-8	393027	1-41	44681-1	2-53
391468	3-8	393028	1-41	44681-2	2-53
391899	2-19	393029	1-9	44681	2-53
391911	2-19	393042	2-57	44906	1-31, 1-37, 2-23, 2-29, 2-31, 2-37, 2-43, 2-49
392171	1-15	393044	2-59	44961	1-31, 1-33, 2-23, 2-25, 2-31, 2-33, 2-39, 2-45
39277	1-29	393048	2-53	45272	2-53, 2-55
392816	1-29	393049	2-55	45283	2-53, 2-55
392818	1-11	393100	2-5	45960	1-29
392822	1-11	393102	2-5	45962	1-47, 2-60
392823	1-35, 2-27, 2-35	393111	2-3	46820	1-13
392827	1-15	393112	1-15	49225	1-19
392838	1-15	393117	1-47	49263	2-53, 2-55, 2-57
392839	1-15	393118	1-47	49266	1-39, 2-5
39284	1-13, 1-25	39312	2-3	49694	1-39, 1-43
392840	1-35, 2-27, 2-35	393125	1-47	49697	2-3
392841	1-35, 2-27, 2-35	393129	1-9, 1-39, 1-43	49800	1-39
392842	1-3, 1-35, 2-27, 2-35	393130	1-11	49826	2-5
392846	1-11	393133	1-39		
		393134	1-15		
		393135	1-13, 1-17		

CROSS REFERENCE

Part Number	Page Number	Part Number	Page Number	Part Number	Page Number
50269	1-29, 1-31, 1-49, 1-51, 2-23, 2-31, 2-41, 2-47	69785	2-5	87816	2-3
50682	1-29	71090	1-51	9000705	1-25
51109	1-25	71211	1-51	9000845	2-53
51225-1	2-3	71607	1-37, 2-29, 2-37, 2-43, 2-49	9000846	2-55
51534	1-29	71793	2-41, 2-47	9000879	2-53, 2-55
53268	2-9	73342	2-5	97031	1-25
53466	2-7	73468	2-5		
54333	1-33, 1-45, 2-9, 2-11, 2-13, 2-15, 2-23, 2-25, 2-31, 2-33, 2-41, 2-47	74455	1-25, 2-41, 2-47		
54745	1-25	75371	1-49		
55248	1-39, 2-5, 2-53, 2-55, 2-57	75611	1-39		
578441	1-43	75934	1-25		
58484	1-11	76099	2-39, 2-41, 2-43, 2-45, 2-47, 2-49		
58518	2-55	76438	2-3		
58519	2-55	77347	2-3		
58520	2-55	78553	1-15		
58979	1-41	78840	2-5		
59668	2-41, 2-47	78841	2-5		
603012	1-39	78842	2-5		
60386	3-3	79246	1-37, 2-29, 2-37, 2-43, 2-49		
606370	1-3, 1-15	79273-1	2-11, 2-13, 2-15		
607776	1-31	79506	2-39, 2-45		
608562	1-49	80317	2-3		
611287000	1-31, 1-33	80318	2-3		
61297	3-3	81537	2-3		
61300	3-3	81538	2-3		
613727	2-7	81539	2-3		
613735	2-7	81540	2-3		
614265	1-45	81541	2-3		
621324	1-43	81542	2-3		
626100	1-45	81580	1-9, 1-39, 1-43		
626121	1-45	81672	1-25		
630068	1-43	82138	1-53, 2-51		
630394	1-43	82829	2-7		
63245-1	1-31, 1-33, 2-23, 2-25, 2-31, 2-33, 2-41, 2-47	82839	1-25		
63248-1	1-7	82889	1-31, 2-23, 2-31, 2-41, 2-47		
63248-2	1-7	83097	1-19, 1-29		
63248-3	1-3, 1-7	83149	1-25		
63248-4	1-7	83332	2-3		
63416	1-51	83347	2-3		
63810	2-5	83348	2-3		
63987-1	2-9, 2-13, 2-15, 2-41, 2-47	86240	1-23		
64173	1-37, 2-29, 2-37, 2-43, 2-49	86759	1-37, 2-29, 2-37, 2-43, 2-49		
64425	1-37, 2-3, 2-29, 2-37, 2-43, 2-49	86780	1-31, 2-23, 2-31, 2-41, 2-47		
64743	2-9, 2-13, 2-15	86781	1-31, 2-23, 2-31, 2-41, 2-47		
64778	2-9	86859	1-3, 1-37, 2-29, 2-37, 2-49		
65441	2-3	86860	1-37, 2-3, 2-29, 2-37, 2-43, 2-49		
65695	1-35, 2-27, 2-35	86865	1-3, 1-37, 2-29, 2-37, 2-43, 2-49		
67767	1-9, 1-19, 1-43, 1-47	86866	1-21, 1-23, 1-29		
69234	1-9, 1-17	87308	1-17		
69461	1-11	87435	1-47		
69582	1-37, 2-29, 2-37, 2-43, 2-49				

PART DESCRIPTION TO PAGE NUMBER CROSS REFERENCE LIST

A

Race Thrust, 4-5, 4-7
 Actuator, 36vdc, 02.0stroke 300lb, 1-49
 Adaptor, Brush, 1-5, 1-7
 Alarm Assy, Backup, 12-48vdc
 82-102dba, 2-57, 2-59
 Angle Wldt, Stop, Side Sqge, Cyl, Head,
 2-43, 2-49
 Angle Wldt, Tool, Lift, Cyl, 28 Inch, 2-41
 Angle Wldt, Tool, Lift, Cyl, 32 Inch, 2-47
 Angle, Bracket, Tank, 1-43
 Angle, Lh, 1-35, 2-27, 2-35
 Angle, Rh, 1-35, 2-27, 2-35
 Angle, Rod, Prop, 1-11
 Arm Wldt, Brake, 1-21, 1-23
 Arm Wldt, Lift, Mop, Lh, 2-3
 Arm Wldt, Lift, Mop, Rh, 2-3
 Arm, Link, Brake, Lh, 1-21, 1-23
 Arm, Link, Brake, Rh, 1-21, 1-23
 Arm, Mtg, Link, Lh Sqge, Cyl Head, 2-43,
 2-49
 Arm, Mtg, Link, Rh Sqge, Cyl Head, 2-43,
 2-49
 Armature, Assy, 250mm, 3-6, 3-7
 Armature, Motor, 250mm, 3-8
 Armature, 3-3

B

Battery, 06vdc, 244ah, Wet, 2-60
 Battery, 06vdc, 180ah, Maint Free, 2-61
 Bearing Assy, Cup/Cone, 1-19
 Bearing Be, 3-4
 Bearing Kit, Front Drive Wheel, Replmnt,
 1-19
 Bearing, Ball, 0.59b 1.26d 0.35w, 2-39,
 2-45
 Bearing, Ball, 0.75b 1.38d 0.50w, 1-13
 Bearing, Ball, 0.98b 2.05d 0.59w, 1-27
 Bearing, Ball, Brush Side, 3-8
 Bearing, Cup, 1-19
 Bearing, Drive End, 3-5
 Bearing, Gearbox Side [Amer], 3-8
 Bearing, Gearbox Side, 3-6, 3-7
 Bearing, Motor Side, 3-6, 3-7, 3-8
 Bearing, Steering, 3-8
 Bearing, Thrust, 2.75b 3.63d 0.13w, 1-19
 Bearing, Thrust, 1-37, 2-3, 2-29, 2-37,
 2-43, 2-49
 Bearing, 3-3, 3-4, 3-5
 Bellcrank, Lift, Sqge, 1-37, 2-29, 2-37,
 2-43, 2-49
 Belt, 15mm 05p 500l, 1-3
 Belt, Replmnt, Brush Drive, F/222201, 2-39,
 2-45
 Blade, Rear, Gum Rbr, 700mm, 1-3
 Blade Assy, Sqge, Side [Linatex], 1-3, 2-49
 Blade Assy, Sqge, Side, 1-3
 Blade, Sqge, Front, 700mm, Linatex, Red,
 1-53

Blade, Sqge, Front, 700mm, Linatex, 1-3
 Blade, Sqge, Front, 700mm, Oil-Rstn, 1-3
 Blade, Sqge, Front, 700mm, 1-3, 1-53
 Blade, Sqge, Front, 800mm, Linatex, 1-3
 Blade, Sqge, Front, 800mm, Oil-Rstn, 1-3,
 2-51
 Blade, Sqge, Front, Oil-Rstn, 700mm,
 1-53
 Blade, Sqge, Lh, 1-3, 1-35, 2-27, 2-35
 Blade, Sqge, Rear, 700mm, Oil-Rstn, 1-3
 Blade, Sqge, Rear, 700mm, 1-3, 1-53
 Blade, Sqge, Rear, 800mm Linatex, Red,
 2-51
 Blade, Sqge, Rear, 800mm, Oil-Rstn, 1-3,
 2-51
 Blade, Sqge, Rear, 800mm, 1-3
 Blade, Sqge, Rear, Gum Rbr, 700mm, 1-3,
 1-53
 Blade, Sqge, Rear, Gum Rbr, 800mm, 1-3,
 2-51
 Blade, Sqge, Rear, Oil-Rstn, 700mm, 1-53
 Blade, Sqge, Rh, 1-3, 1-35, 2-27, 2-35
 Blade, Sqge, Front, 800mm Linatex Red,
 2-51
 Blade, Sqge, Front, 800mm Linatex, Red,
 2-51
 Blade, Sqge, Front, 800mm, 1-3
 Bladeholder Wldt, Sqge, Disk, Lh, 1-37,
 2-29, 2-37
 Bladeholder Wldt, Sqge, Disk, Rh, 1-37,
 2-29, 2-37
 Block, Centering, 1-51
 Block, Sqge, Adj, 1-51
 Bolt, Shld, .31d X 1.00, .25-20, 1-25
 Bolt, Shld, .50d X 4.25, .38-16, 1-29
 Boot, 90deg .50d .57d X .84, 1-47
 Box, Elec, Connection, 3-8
 Bracket Wldt, Bar, Spray, 800mm [7100],
 2-15
 Bracket Wldt, Bar, Spray, 700mm [7100],
 2-13
 Bracket Wldt, Box Detgt, 2-7
 Bracket Wldt, Guide, Actuator, 1-29
 Bracket Wldt, Light, 2-53, 2-55, 2-57
 Bracket, Bar, Spray, 2-13, 2-15
 Bracket, Brake, Complete, 3-8
 Bracket, Brake, Pivot, 1-21, 1-23
 Bracket, Cable, 1-41
 Bracket, Channel, Mtg, Brake, 1-25
 Bracket, Fan End, 3-3
 Bracket, Fan, 1-41
 Bracket, Filter, 1-39
 Bracket, Guide, Hose, 2-41, 2-47
 Bracket, Keeper, 2-3
 Bracket, Link, Head, Disk, 1-31, 1-33,
 2-23, 2-25, 2-31, 2-33
 Bracket, Mtg, Motor, 2-39, 2-45
 Bracket, Pump, Es, 2-5
 Bracket, Retainer, Spring, 1-5, 1-7
 Bracket, Shield, 2-39, 2-45
 Bracket, Wheel, Sqge, Rear, 1-53, 2-51

Bracket, 2-7
 Brake, Band [Amer], 3-7, 3-8
 Brush Assy, Disk, Scb, 14.0 D, Nyl, 1-5
 Brush Assy, Disk, Scb, 14.0 D, Pyp, 1-5
 Brush Assy, Disk, Scb, 14.0 D, Super Abr,
 1-5
 Brush Assy, Disk, Scb, 16.0 D, Nyl, 1-7
 Brush Assy, Disk, Scb, 16.0 D, Pyp, 1-7
 Brush Assy, Disk, Scb, 16.0 D, Super Abr,
 1-7
 Brush Assy, Motor, 1-31, 1-33
 Brush Kit, Carbon, 3-8
 Brush Kit, Cover, 3-8
 Brush Kit, Motor, 3-8
 Brush Kit,, 3-4
 Brush Mechanism, 3-3
 Brush, Scb, 28l, 18 Sr, Abr, Spl, 1-5
 Brush, Scb, 28l, 18 Sr, Nyl, Spl, 1-5
 Brush, Scb, 28l, 18 Sr, Pyp Grout ,Spl,
 1-3
 Brush, Scb, 28l, 18 Sr, Pyp Grout, Spl, 1-5
 Brush, Scb, 28l, 18 Sr, Pyp, Spl, 1-5
 Brush, Scb, 32l, 18 Sr, Abr, Spl, 1-7
 Brush, Scb, 32l, 18 Sr, Nyl, Spl, 1-7
 Brush, Scb, 32l, 18 Sr, Pyp Grout ,Spl,
 1-3
 Brush, Scb, 32l, 18 Sr, Pyp Grout, Spl, 1-7
 Brush, Scb, 32l, 18 Sr, Pyp, Spl, 1-7
 Brush, 3-5
 Bumper Wldt, V-Mop, 2-3
 Bushing Assy, Flng, 2 Hole, 0.75b, Nyl,
 1-13
 Bushing, Flng, 0.44b 1.25d 0.25l, 1-25
 Bushing, Flng, 0.50b 0.59d 0.38l, 1-31,
 1-33, 1-49, 2-3, 2-23, 2-25, 2-31,
 2-33, 2-41, 2-47
 Bushing, Flng, 0.63b 0.75d 0.38l, 1-51
 Bushing, Sleeve, 0.50b 0.59d 0.38l, Stil,
 1-37, 2-29, 2-37, 2-43, 2-49
 Bushing, Sleeve, 0.62b 0.72d 0.50l, Fgl,
 2-3
 Bushing, Sleeve, 0.63b 0.72d 0.38l, 1-37,
 2-29, 2-37, 2-43, 2-49

C

Cable Assy, Battery, 04ga 2, 175a, 1-47
 Cable Assy, Battery, 06ga 2, 50a/175a,
 2-62
 Cable, Battery, 1-47
 Cable, Water Flow, [Ezrider Hp], 1-45
 Cable, 1-41
 Caliper, Brake, 3-6
 Cam, Adj, Sqge, 1-53, 2-51
 Cap, Axle, Vyl, 02.38d, 1-27
 Cap, Brush Holder, 3-5
 Cap, Plstc, .04 1.38 X 2.30 0.5l, 1-47
 Chain, Coil, Str, #210, 06.9l 05 Link, 1-51
 Chain, Roller #35, .375 Pitch, 1-13
 Channel Wldt, Actuator, Mtg, 1-29

CROSS REFERENCE

Channel Wldt, Lift Tool, 1-31, 1-33, 2-25, 2-33
Channel Wldt, Lift, Lh, 2-3
Channel Wldt, Lift, Rh, 2-3
Channel Wldt, Mtg, Spring, 1-25
Channel Wldt, Mtg, Tool, Lift, 1-29
Channel Wldt, Sppt, 1-29
Channel Wldt, Tool, Lift, Cyl [Ezrider], 2-41, 2-47
Channel Wldt, Tool, Lift, Disk [Ezrider], 2-23, 2-31
Channel, .18 0.50 0.03 29.0l, 2-41
Channel, .18 0.50 0.03 33.0l, 2-47
Channel, Brake, 1-23
Channel, Input, Tool, Lift, 1-29
Channel, Sqge, Lower, 1-51
Channel, Sqge, Upper, 1-51
Charger, 36vdc 30a 50hz 1ph 245vac, 2-62
Charger, 36Vdc, 020A 50/60Hz, 2-62
Circuitbreaker, 10.0a, 2-17
Clamp Hose .73-.77 2 Wire Blk, 1-31
Clamp, Cable, Stl, 0.38d X 0.38w, 1h, 2-53, 2-55, 2-57
Clamp, Cable, Stl, 0.56d X 0.38w, 1h, 1-9, 1-19, 2-53, 2-55, 2-57
Clamp, Cable, Stl, 0.63d X 0.75w, 1h, 2-7
Clamp, Cable, Stl, 0.69d X 0.62w, 1h, 1-9, 1-19, 1-43, 1-47
Clamp, Cable, Stl, 0.88d X 0.62w, 1h, 1-11
Clamp, Cable, Stl, 0.9x1.8 X 0.88w, 1h, 1-9, 1-17
Clamp, Cable, Stl, 1.00d X 0.75w, 1h, 1-9, 1-17
Clamp, Cable, Stl, 1.50d X 1.00w, 1h, 2-7
Clamp, Hose .40 - .42 2 Wire, 2-7
Clamp, Hose 1-5/16 To 2-1/4 Ss, 1-43
Clamp, Hose, Wormdrive, 0.31-0.88d, 1-33, 1-45, 2-9, 2-11, 2-13, 2-15, 2-23, 2-25, 2-31, 2-33, 2-41, 2-47
Clamp, Hose, Wormdrive, 0.56-1.06d, 2-5
Clamp, Hose, Wormdrive, 1.56-2.50d, 1-41
Clamp, Hose, Wormdrive, 1.62-3.50d, 1-43, 2-5, 2-9
Clip, Hanger, Hose, 1-43
Clip, Hose, Hanger, 1-43
Collar, Locking, 1-49
Comm. Bracket, 3-3
Connector, 2 Conductor, 3-3, 3-4
Connector, 2-Conductor, 3-5
Connector, Anderson, 175a, Gray, 1-47
Contact, Switch, 1-15
Controller, Mach, 1-17
Coupling, Fem, W/Valve, .25 Brb, 2-7
Cover, Elec, Connection, 3-8
Cover, Tank, Mold, Ce [7080], 1-39
Cover, Terminal, Battery, Pye, 2-60
Cup Holder, 1-11

D

Deflector, Water, 1-3, 2-39, 2-45
Detergent Pkg, 2 Liter, Sgl. (365), 2-7
Detergent Pkg, 2 Liter, Sgl. (665), 2-7
Device, Centering, 1-5, 1-7
Diode, Ele, Plug, 2-19
Disk, Pad Driver, W/ Face, 14d, 1-5
Disk, Pad Driver, W/ Face, 16d, 1-7
Door Wldt, Mtg, Lh, 28 Inch Disk, 1-37, 2-29
Door Wldt, Mtg, Rh, 28 Inch Disk, 1-37, 2-29
Door Wldt, Sqge, Side, Lh, 800mm Disk, 2-37
Door Wldt, Sqge, Side, Rh, 800mm Disk, 2-37
Door, Brush, 2-39, 2-45
Drain Kit, 1-47
Driver Assy, Pad. 14D, 1-5
Driver Assy, Pad. 16D, 1-7
Driver Assy, Pad, 14d, 1-3
Driver Assy, Pad, 16d, 1-3
Duct, Pvc, 0.40 X 0.75 0.40l, 1-19

E

Endbell, Brush End, Motor-Ele, 3-5

F

Fan Assy, Vacuum (See Breakdowns), 1-41
Fan, Vacuum, 3-3
Fan, 3-3
Filter Assy, Air, Molded Ure, 2-7
Filter, Fan, 1-39
Filter, Foam, 2-11, 2-13, 2-15
Filter, Inline, Pf06/Pf06, 80 Mesh, 2-9
Fitting Assy, Cap, 0.045b, Pm04/Bm08, 2-9
Fitting, Brs, E90, Cf03/Pf02, 2-7
Fitting, Brs, E90, Pm04/Bm08, 2-11, 2-13, 2-15
Fitting, Brs, Str, BM06/PM04, 1-47
Fitting, Brs, Str, Pm02/Bm04, 2-7
Fitting, Brs, Str, Pm04/Pf02, 2-9
Fitting, Brs, Tee, Pf04/Pm04/Pf04, 2-9
Fitting, Grease, Str Pm04 .47l, 1-19
Fitting, Plstc, Cap, Pf04, 2-7
Fitting, Plstc, E90, Bm08/Bm08, 2-9, 2-13, 2-15, 2-41, 2-47
Fitting, Plstc, E90, Bm08/Pm04, 2-11, 2-13, 2-15
Fitting, Plstc, E90, Bm08/Pm06, 2-9
Fitting, Plstc, E90, Bm08/Pm12, Nyl, 2-11, 2-13, 2-15
Fitting, Plstc, E90, Bm10/Pm12, 2-5
Fitting, Plstc, E90, Pm12/Pf12, 2-5
Fitting, Plstc, Plug, Pm12, 1-39
Fitting, Plstc, Str, Bm08/Bm08, 1-45, 2-9
Fitting, Plstc, Str, Bm08/Pm06, 2-9, 2-13, 2-15

Fitting, Plstc, Str, Bm08/Pm12, 2-11, 2-13, 2-15
Fitting, Plstc, Str, Bm10/Pm12, 2-5
Fitting, Plstc, Str, Pf12/Pf12, 2-5
Fitting, Plstc, Str, Pm04, Cplg, Male, 2-7
Fitting, Plstc, Str, Pm12/Pm12 03.0l, 2-5
Fitting, Plstc, Str, Spcl, 12pm/10cf, 1-45
Fitting, Plstc, Tee, Bm08/Bm04/Bm08, 2-11, 2-13, 2-15
Fitting, Plstc, Tee, Bm08/Bm08/Bm08, 1-31, 1-33, 2-23, 2-25, 2-31, 2-33, 2-41, 2-47
Fitting, Plstc, Y, Bm08/Bm08/Bm08 Nyl, 2-11
Fitting, Vyl, Y, Formed, 0.5id, 2-9
Flap, Strainrelief, 1-19
Flapper, Valve, 2-5
Frame Wldt, Linkage, Sqge, 1-51
Frame Wldt, Micro Scrubber, 1-9
Frame Wldt, Mop, V, 2-3
Frame Wldt, Sqge, Lh, Cyl, 2-49
Frame Wldt, Sqge, Side, Lh, 2-43
Frame Wldt, Sqge, Side, Rh, 2-43
Frame, Casting, Sqge, 700mm, 1-53
Frame, Casting, Sqge, 800mm, 2-51
Frame, Side Squeegee Rh, 2-49
Fuse, 125 Amp, 58vdc, 1-17
Fuse, Blade, 10a, 58vdc, 1-61, 1-65

G

Gasket Strip, 1-3, 1-15
Gasket, Check, Valve, 2-5
Gasket, Hourmeter, 1-15
Gasket, Shield, 1-3, 2-39, 2-45
Gauge, Battery, 1-15
Gauge, Hourmeter, 12-80 VDC Analog, 1-15
Gearbox, Wheel, 250mm, 36vdc Band Brake (See Breakdowns), 1-19
Gearbox, Wheel, 250mm, 36vdc Band Brake, 3-7, 3-8
Gearbox, Wheel, Front, 250mm (See Breakdowns), 1-19
Gearbox, Wheel, Front, 250mm, 3-6
Grommet, Rbr, 0.62id, F/ 0.9h, .12matl, 2-53, 2-55
Grommet, Rbr, 0.89id, F/ 1.2h, .14matl, 1-25
Grommet, Rbr, 1.31id, F/ 1.6h, .12matl, 1-29, 1-47
Guard Wldt, Light, Revl/Flsh, 2-53, 2-55
Guard, Belt, Drive, Scrbr Head, Lh, 2-39, 2-45
Guard, Belt, Lh, 2-39, 2-45
Guard, Belt, Rh, 2-39, 2-45
Guide Wldt, Linkage, Sqge, 1-49
Guide, Side Sqge, 1-3, 1-37, 2-29, 2-37, 2-43, 2-49

H

Handle, Hood, 1-11
 Harness [Ez Rider Hp Fast], 2-19
 Harness [Fast Ezriderhp], 2-19
 Harness, Main, [Ezrider Hp], 1-65, 1-69
 Harness, Pedal, 1-25
 Harness, Switch, Seat, 1-11
 Harness, Traction, [Ezrider Hp], 1-65, 1-69
 Harness, Wire [Ez Rider Hp], 1-61
 Harness, Wire, Es Pump, 1-61, 1-65, 1-69
 Harness, Wire, Hourmeter, Jumper, 1-61, 1-65, 1-69
 Harness, Wire, Traction Motor, 1-19
 Head Wldt, Disk, 32 Inch Scb, 2-33
 Head Wldt, Scb, Disk, 28 Inch, 1-33, 2-25
 Head Wldt, Scb, Disk, 700mm, 1-31, 2-23
 Head Wldt, Scb, Disk, 800mm, 2-31
 Hinge, .25pin .08 3.5w 13.0l 4/.25slot, 1-39
 Hinge, .25pin .12 3.0w 03.0l 4/0.28slot, 1-11
 Horn, 12-48 Vdc, 1-9
 Hose, .25id X 12" Pvc (C460126), 2-7
 Hose, Afmkt Pvc, Brd 0.50id X 1 Ft (376716), 1-31, 1-33, 2-9, 2-11, 2-13, 2-15, 2-23, 2-25, 2-31, 2-33
 Hose, Afmkt Pvc, Brd 0.50id X 2 Ft (376716), 2-9, 2-11, 2-13, 2-15
 Hose, Afmkt Pvc, Brd 0.62id X 1 Ft (C460117), 2-11
 Hose, Afmkt, Pvc, Clr 0.25id 3ft (C460126), 2-7
 Hose, Afmkt, Pvc, Clr, 0.38ld 1Ft (C080172), 1-47
 Hose, Drain, 1.50id X 32.0l Scrubber, 1-43
 Hose, Drain, 1-43
 Hose, Pvc, Brd, 0.50id (376716), 1-31, 1-33, 2-23, 2-25, 2-31, 2-33
 Hose, Pvc, Brd, 0.50ld, 0.73Od, 15.0L (376716), 1-45
 Hose, Pvc, Brd, 0.50id, 0.73od, 21.0l (376716), 1-45
 Hose, PVC, Brd, 0.62id 0.96od 6.50L (C460117), 2-5
 Hose, Pvc, Clr, 0.50id 0.69od 01.50l, 2-41, 2-47
 Hose, Vacuum, 1-3, 1-39
 Housing Assy, Steering [7100/Ez Rider], 1-13
 Housing Assy, Wheel [7100/Ez Rider], 1-27
 Housing Wldt, Quick-Mop, 2-3
 Housing, Cyl, Mach 700mm, 2-41
 Housing, Cyl, Mach 800mm, 2-47
 Housing, 3-3
 Hub, Drive, Brush, Disk, 0.75B 6T, 1-31, 2-23, 2-31
 Hub, Drive, Brush, Disk, 0.75b 6t, 1-33, 2-25, 2-33

I

Insulation, Acstc, 1-39

Insulator, Mtg, Fuse, 1-17
 International Only, 2-62

J

Joint U, 1-13

K

Key Square 0.25 0.25 01.00 Lg, 3-4
 Key, Replmt, 1-15
 Key, Sq, 0.12 X 0.12, 01.00l, 3-5
 Key, Sq, 0.19 X 0.19, 01.00l, 1-13
 Key, Sq, 0.25 X 0.25, 0.75l, 1-33
 Key, Sq, 0.25 X 0.25, 00.75l, 1-31
 Kit, Brace, 3-5
 Kit, Brush, Cover, 3-6, 3-7
 Kit, Brush, Motor, 3-6, 3-7
 Kit, Brush, 3-5
 Kit, Ci, Alarm, Backup, W/ Bracket, 2-57
 Kit, Ci, Alarm, Backup, W/O Bracket, 2-59
 Kit, Ci, Battery, 36vdc, 244ah Wet, 2-60
 Kit, Ci, Charger, 36vdc, 30a,50hz,245vac(See Breakdowns), 2-62
 Kit, Ci, Chrgr, 36vdc 025a 50hz 230vac, 2-62
 Kit, Ci, Chrgr, 36vdc 025a 60hz 120vac, 2-62
 Kit, Ci, Light, Flsh [Ezhp/7080], 2-55
 Kit, Ci, Light, Revl [Ezhp/7080], 2-53
 Kit, Ci, Scrubhead, 700mm, 1-31, 2-23
 Kit, Ci, Scrubhead, 800mm, 2-31
 Kit, Ci, Sqge Assy, Rear, 700mm[Ez/7080], 1-53
 Kit, Ci, Sqge Assy, Rear, 800mm[Ez/7080], 2-51
 Kit, Ci, Sqge, Linatex, 700mm[Ez/7080], 1-53
 Kit, Ci, Sqge, Linatex, 800mm[Ez/7080], 2-51
 Kit, Ci, V-Mop, 2-3
 Kit, Di, Es [Ezrider Hp/7080], 2-5
 Kit, Motor Bearing, 3-5
 Kit, Repair, Diaphragm, Air Compressor, 2-7
 Kit, Replmt, Actuator, 1-29
 Kit, Sqge, Oil-Rstn, 700mm, 1-3, 1-53
 Kit, Sqge, Oil-Rstn, 800mm [7100], 2-51
 Kit, Sqge, Oil-Rstn, 800mm, 1-3
 Kit, Sqge, Tile, 700mm, 1-3, 1-53
 Kit, Sqge, Tile, 800mm [7100], 2-51
 Kit, Sqge, Tile, 800mm, 1-3
 Kit, Tray, Debris, 28 In, 2-41
 Kit, Tray, Debris, 32 In, 2-47
 Kit, Valve, Check, 2-5
 Kit, Water, Valve, Rebuild, 1-45
 Knob Assy, Rnd, 1.00d 0.50l .25-20 1.5l, 2-51
 Knob, 4-Prong W/.31-18, Insert, 1-53
 Knob, Rnd, . D . L, 1-39
 Knob, Rnd, 0.71d 0.75l 0.25b Plstc, 1-45

Knob, Star, 2.8 4ear 1.1l .31-18 Plstc, 2-51

Knob, 1-51, 1-53

L

Label [Nfsi Certification], 1-70
 Label Set, Info/hzrd, 1-70
 Label, [Quick Mop], 2-3
 Label, Attention Fast Users, 2-21
 Label, Fast, 2-21
 Label, Instmt [Ezrider Hp], 1-70
 Label, Model, [Ezrider Hp Fast], 2-21
 Label, Std Opertnl, 1-70
 Lamp Assy, Flsh , 2-55
 Lamp Assy, Revl , 2-53
 Lamp, 40vdc, 0.9a, 2-53, 2-55
 Lamp, Bulb, Lamp, Flsh, 2-53
 Lamp, Bulb, Lamp, Strobe, 2-55
 Lamp, Strobe, Amb, 12-80 Vdc , 2-55
 Latch, Door, 2-3
 Latch, 1-35, 1-39, 2-27, 2-35
 Lens, Amber, Light, Flsh, 2-55
 Lens, Amber, Light, Revl, 2-53
 Lens, Blue, Light, Flsh, 2-55
 Lens, Blue, Light, Revl , 2-53
 Lens, Blue, Option, F/Revl/Flsh Light, 2-53, 2-55
 Lens, Lamp, Amb, Strobe/Flasher, 2-53, 2-55
 Lens, Red, Light, Flsh, 2-55
 Lens, Red, Light, Revl, 2-53
 Lens, Red, Option, F/Revl/Flsh Light, 2-53, 2-55
 Lever, Lock, Side Sqge, 1-37, 2-29, 2-37
 Light, Flsh, Amb, 12-48 Vdcl , 2-53
 Light, Panl, 36vdc, 1.1 X 1.0, 1-15
 Link, Balljoint, .38-24, 10.5l, 1-49, 1-51
 Link, Balljoint, M10 X 1.5, 11.0L, 1-31, 1-33, 2-23, 2-25, 2-31, 2-33
 Link, Brake, 1-21, 1-23
 Link, Chain, Roller, #35, 1-13
 Linkage Kit, Brake, Replmt., 1-21
 Linkage Kit, Brake, Replmt, 1-23, 1-25
 Lip, Debris Tray, 28in, 2-41
 Lip, Debris Tray, 32 In, 2-47

M

Manual Pkg, [7080 Ele Na], 2-64
 Manual, Fiche, [7080 Ele Na], 2-64
 Module, Timer, Detgt, 36vdc, 2-17
 Molding, Trim, .08-.11 10.00, 1-9
 Molding, Trim, .08-.11 19.00, 1-11
 Molding, Trim, Pvc, .08-.11 04.75l, 2-3
 Molding, Trim, Rbr, .13 03.0, 1-33, 2-25
 Mop, Dust, Industrial, 2-3
 Mop, Dust, 2-3
 Motor Assy, Ele, 36Vdc, 0.75Hp (See Breakdowns), 2-39, 2-45
 Motor Assy, Ele, 36Vdc, 0.75Hp, 1700Rpm, 3-5

CROSS REFERENCE

Motor, 36 Vdc, 0.8Hp, 320 Rpm, 3-4
Motor, Ele, 36vdc, 0.50hp, 0320rpm, 1-31, 1-33
Motor, Ele, 36vdc, 0.80hp, 0320rpm (See Breakdowns), 2-23, 2-25, 2-31, 2-33
Mount, Cable Tie, 1-39, 2-5, 2-53, 2-55, 2-57
Muffler, Vacuum Fan, 1-41

N

Nut, Hex, Flexlock, .31-18, 1-47
Nut, Hex, Fling, M06 X 1.0, 1-11
Nut, Hex, Fling, M08X1.25, 1-11
Nut, Hex, Jam, .38-24, Lh, 1-31, 2-23, 2-31, 2-41, 2-47
Nut, Hex, Jam, .38-24, 1-31, 2-23, 2-31, 2-41, 2-47
Nut, Hex, Lock, .25-20, Ni, 1-25
Nut, Hex, Lock, .31-18, Ni, 1-11
Nut, Hex, Lock, .38-16, Ni, Thin, 1-29
Nut, Hex, Lock, .38-24, Ni, Ss, 1-29, 1-31, 1-49, 1-51, 2-23, 2-31, 2-41, 2-47
Nut, Hex, Lock, .38-24, Ni, Thin, 1-49, 1-51
Nut, Hex, Lock, .50-13, Ni, Ss, 2-43, 2-49
Nut, Hex, Lock, M 5 X 0.8, Ni, 2-17
Nut, Hex, Lock, M 6 X 1.0, Ni, 2-17
Nut, Hex, Lock, M 8 X 1.25, Ni, Ss, 2-7
Nut, Hex, Lock, M04 X 0.7, Ni, 1-25, 2-3
Nut, Hex, Lock, M05 X 0.8, Ni, 1-17
Nut, Hex, Lock, M05X0.8, Ni, 1-11
Nut, Hex, Lock, M06 X 1.0, Ni, Ss, 1-9, 1-19, 1-21, 1-23, 1-31, 1-33, 1-37, 1-41, 1-45, 1-51, 2-23, 2-25, 2-29, 2-31, 2-33, 2-37, 2-41, 2-47
Nut, Hex, Lock, M06 X 1.0, Ni, 1-11, 1-15, 1-21, 2-53, 2-55, 2-57, 2-59
Nut, Hex, Lock, M08 X 1.25, Ni, Ss, 1-51, 1-53, 2-39, 2-45, 2-51
Nut, Hex, Lock, M08 X 1.25, Ni, 1-13, 1-17, 2-3
Nut, Hex, Lock, M10 X 1.5, NL, SS, 1-31, 1-33, 2-23, 2-25, 2-31, 2-33
Nut, Hex, Lock, M10 x 1.5, Ni, Ss, 1-29
Nut, Hex, Lock, M10 X 1.5, Ni, 1-25, 2-3
Nut, Hex, Lock, M12 X 1.75, Ni, 1-13
Nut, Hex, Lock, M5 X 0.8, Ni, 2-53, 2-55
Nut, Hex, Sltd, 1.25-12, 1-19
Nut, Hex, Std, M03 X 0.5, 1-15
Nut, Hex, Std, M08 X 1.25, 2-3
Nut, Hex, Std, M10 X 1.5, 2-3
Nut, Isolator, .25-20 Wall Thk .187-.343, 2-53, 2-55, 2-57
Nut, Speed, Clip, .25-20 [.025-.150], 2-51
Nut, Speed, Retainer, .25-20, 1-53
Nut, T, M 10 X1.5 0.6230d .516lg, 1-37, 2-29, 2-37, 2-43, 2-49
Nut, T, M8x1.25 X0.4980d, 0.516lg, 1-37, 2-29, 2-37, 2-43, 2-49
Nut, Wheel, .44-20 X 60 Angle, 1-27
Nut, 3-3

O

Oil Seal, 3-4

P

Pad, Buff, 14.0d, Red, 1-3, 1-5
Pad, Buff, 16.0d, Red, 1-3, 1-7
Pad, Polish, 16.0d, White, 1-7
Pad, Polish, 14.0d, White, 1-5
Pad, Scrub, 14.0d, Blue, 1-5
Pad, Scrub, 16.0d, Blue, 1-7
Pad, Strip Hd, 14.0d, Black, 1-5
Pad, Strip Hd, 16.0d, Black, 1-7
Pad, Strip, 14.0d, Brown, 1-5
Pad, Strip, 16.0d, Brown, 1-7
Pad, 1-25
Panel, Front, 1-11
Panel, Instmt [Ezrider Hp/7080], 1-15
Panel, Tank, Filler, Plstc, Ce [7080], 1-9
Pedal Assy, Foot, 1-25
Pedal Wldt, Brake, 1-25
Pedal, Brake, Lock, 1-25
Perf Kit, Brush, Cyc, 28 In, 1-3
Perf Kit, Brush, Cyl, 32 In, 1-3
Perf Kit, Brush, Disk, 28 In, 1-3
Perf Kit, Brush, Disk, 32 In, 1-3
Pin Kit, Retainer, Snap Rings, 3-8
Pin, Brake, 1-21
Pin, Clevis, 0.19 D X 1.00l, 1-21, 1-23
Pin, Clevis, 0.31 D X 1.00l, 1-37, 2-29, 2-37, 2-43, 2-49
Pin, Clevis, 0.37 D X 0.75l, 1-37, 2-3, 2-29, 2-37, 2-43, 2-49
Pin, Clevis, 0.37 D X 1.50l, 1-25, 1-49
Pin, Clevis, 0.37 D X 1.75l, 1-29
Pin, Clevis, 0.37 D X 2.62l, 1-37, 2-29, 2-37
Pin, Clevis, 0.37 D X 3.00l, 1-53, 2-51
Pin, Clevis, 0.38 D X 1.13l, 1-23
Pin, Clevis, 0.38d X 1.25l, 1-23
Pin, Clevis, 0.50 D X 2.00l, 1-29
Pin, Clevis, 0.50 D X 2.25l, 1-29
Pin, Clevis, 0.50 D X 3.50l, 1-49
Pin, Clevis, 0.50 D X 3.75l, 1-25
Pin, Clevis, 0.50 D X 4.00l, 1-29, 1-31, 1-33, 2-23, 2-25, 2-31, 2-33
Pin, Clevis, 0.50 D X 4.50l, 2-41, 2-47
Pin, Clevis, 0.50 D X 4.75l, 1-35, 2-27, 2-35
Pin, Clevis, 0.50 D X 6.00l, 2-3
Pin, Cotter, .062 X 0.50, 1-21, 1-23
Pin, Cotter, .094 X 0.75, 1-25, 1-49, 1-53, 2-51
Pin, Cotter, .125 X 1.00, 1-23, 1-25, 1-37, 1-49, 2-29, 2-37
Pin, Cotter, .125 X 1.25, 1-35, 2-27, 2-35
Pin, Hair Cotter, 0.38 D .072 Wir, 1-29
Pin, Hair Cotter, 0.43 D .079 Wir, 2-41, 2-47
Pin, Hair Cotter, 0.62 D .120 Wir, 1-29, 1-33, 2-3, 2-25, 2-33

Pin, Hair Cotter, 0.69 D .092 Wir, 1-31, 1-37, 2-23, 2-29, 2-31, 2-37, 2-43, 2-49
Pin, Hair, Cotter, 0.38d .072wir, 1-21, 1-23
Pin, Roll, .090 D 0.25l, .094/.097, 2-39, 2-45
Pivot Wldt, Actuator, 1-49
Plate Wldt, Mtg, Wheel, 1-9
Plate Wldt, Swivel, 1-19
Plate Wldt, Tool, Lift, Cyl, 2-41, 2-47
Plate, Adapter, Wheel, 1-19
Plate, Backup, Sqge, Lh, 1-35, 2-27, 2-35
Plate, Backup, Sqge, Rh, 1-35, 2-27, 2-35
Plate, Latch, 2-3
Plate, Mounting, Tool Lift, Sc, 2-41, 2-47
Plate, Mtg, Light, 1-15
Plate, Orifice, 0.045id, 2-9
Plate, Retainer, Blade, 700mm, 1-53
Plate, Retainer, Blade, 800mm, 2-51
Plate, Seat W/ Labels, Blk, 1-11
Plate, Sppt, Gauge, Battery, 1-15
Plate, Swivel, Bottom, 1-19
Plug Assy, Drive, Brush, 2-39, 2-45
Plug Assy, Idler, Brush, 2-39, 2-45
Plug Expansion 1-1/2"Dia, 1-43
Plug, Drive, Brush, 2-39, 2-45
Plug, Expansion, 2.00 Dia, 1-43
Plug, Idler, Brush, 2-39, 2-45
Plug, Tank, Solution, 1-43
Pump, Air, Ele, 36vdc, 2-7
Pump, Detgt [560s], 2-7
Pump, Soltm, Ele, 36vdc, 2-9
Pump, Solution, Impeller, 36vdc, 2-5

R

Rail, 1-11
Relay, 36vdc, 05a, Spdt N/O [Greenwich], 2-17
Retainer Wldt, Blade, Sqge, 1.2w 41.0l, 2-51
Retainer Wldt, Sqge, 700mm, 1-53
Retainer, Lh, 2-27, 2-35
Retainer, Lh, 1-35
Retainer, Rh, 1-35, 2-27, 2-35
Retainer, Sqge, 1-37, 2-29, 2-37, 2-43, 2-49
Ring, Brush Holder, 3-8
Ring, Mtg, Sqge, 1-53, 2-51
Ring, Retaining, Ext, 0.59d, Basic, 2-39, 2-45
Ring, Retaining, Ext, 1.00d, Basic, 1-27
Ring, Snap, 3-5
Rod Wldt, Prop, 1-11
Rod, Lift, Sqge, 1-49
Rod, Thrld, 2 End, .38-24 09.0l Lh/Rh, 1-31, 2-23, 2-31, 2-41, 2-47
Rod-End, .38-24lh Fem 0.38-24stud, 1-31, 2-23, 2-31, 2-41, 2-47
Rod-End, .38-24rh Fem 0.38-24stud, 1-31, 2-23, 2-31, 2-41, 2-47
Roller, Linkage, Head, 1-35, 2-27, 2-35
Rotor, Brake, 14mm, 3-6

S

- Screen, 50 Mesh, Ss, 2-9
Screen, Drain, 1-45
Screen, Fan Inlet, 1-41, 3-3
Screen, Fltr, 80 Mesh, 2-9
Screw, Btn, M12 X 1.75 X 25, 10.9 NI, 1-19, 1-29
Screw, Btn, M6 X 1.0 X 20, Blk, 1-15
Screw, Btn, M8x 1.25 X 20, Blk, 1-13, 1-17
Screw, Flat, M06 X 1.0 X 16, 10.9, 1-21
Screw, Flat, M08-1.25 X 30, Ss, 2-45
Screw, Flat, M08-1.25x 20, Ss, 1-37, 2-29, 2-37, 2-43, 2-49
Screw, Flat, M08-1.25x 30, Ss, 2-39
Screw, Flat, M10 X 1.5 X 20, Ss, NI, 2-39, 2-45
Screw, Flat, M10 X 1.5 X 20, Ss, 2-43, 2-49
Screw, Hex, .25-20 X 0.62, Ss, 1-9
Screw, Hex, .25-20 X 0.75, Ss, 1-31, 1-33
Screw, Hex, .25-20 X 1.25, Sems, 2-53, 2-55, 2-57
Screw, Hex, .31-18 X 0.75, Ss, 1-31, 1-33, 2-23, 2-25, 2-31, 2-33
Screw, Hex, .38-16 X 0.75, Ss, 2-23, 2-25, 2-31, 2-33
Screw, Hex, .50-13 X 5.00, 5, 2-43, 2-49
Screw, Hex, M04 X 0.7 X 20, 8.8, 1-25
Screw, Hex, M06 X 1.0 X 20, Ss, 1-33, 1-37, 2-25
Screw, Hex, M06 X 1.0 X 12, 8.8, 1-17
Screw, Hex, M06 X 1.0 X 12, Fmg, 1-25, 2-41, 2-47
Screw, Hex, M06 X 1.0 X 16, Fmg, 1-19
Screw, Hex, M06 X 1.0 X 16, Ss, 1-19, 1-39, 2-39, 2-45
Screw, Hex, M06 X 1.0 X 20, 8.8, 1-11, 2-53, 2-55, 2-57, 2-59
Screw, Hex, M06 X 1.0 X 20, NI, 1-25
Screw, Hex, M06 X 1.0 X 20, Ss, 1-9, 1-21, 1-23, 1-31, 1-41, 1-45, 2-23, 2-29, 2-31, 2-33, 2-37
Screw, Hex, M06 X 1.0 X 25, 8.8, 1-11
Screw, Hex, M06 X 1.0 X 25, Fmg, 1-19
Screw, Hex, M06 X 1.0 X 25, Ss, 1-9, 1-35, 1-51, 2-27, 2-35, 2-41, 2-47
Screw, Hex, M06 X 1.0 X 30, 8.8, 1-17
Screw, Hex, M06 X 1.0 X 40, Ss, 1-41
Screw, Hex, M06 X 1.0 X 55, Ss, 1-41
Screw, Hex, M06 X 1.0 X 80, Ss, 1-41
Screw, Hex, M08 X 1.25 X 30, Ss, 1-53, 2-51
Screw, Hex, M08 X 1.25 X 16, Ss, NI, 2-5
Screw, Hex, M08 X 1.25 X 20, 8.8, 1-9, 1-11
Screw, Hex, M08 X 1.25 X 20, Ss, NI, 1-11, 1-39, 1-43, 1-49
Screw, Hex, M08 X 1.25 X 20, Ss, 1-9, 1-39, 1-41, 1-43, 1-49, 1-51, 2-7, 2-39, 2-45
Screw, Hex, M08 X 1.25 X 25, 8.8, 1-29
Screw, Hex, M08 X 1.25 X 25, Fmg, 2-39, 2-41, 2-43, 2-45, 2-47, 2-49
Screw, Hex, M08 X 1.25 X 25, Ss, 1-47, 1-51
Screw, Hex, M08 X 1.25 X 30, Ss, 2-41, 2-47
Screw, Hex, M08 X 1.25 X 35, Ss FI, 2-39, 2-45
Screw, Hex, M08 X 1.25 X 50, Ss, 1-39, 1-43
Screw, Hex, M08 X 1.25 X 55, Ss, 1-19
Screw, Hex, M08 X 1.25 X 60, 8.8, 1-9
Screw, Hex, M08 X 1.25 X 60, FI, 2-3
Screw, Hex, M08 X 1.25 X 60, Ss, 1-21
Screw, Hex, M08 X 1.25 X 70, Ss, 1-53, 2-51
Screw, Hex, M10 X 1.5 X 20, Ss, 1-37
Screw, Hex, M10 X 1.5 X 20, SS, NL, 1-31, 1-33, 2-23, 2-25, 2-31, 2-33
Screw, Hex, M10 X 1.5 X 20, Ss, 2-29, 2-37
Screw, Hex, M10 X 1.5 X 35, 8.8, 1-13, 1-25
Screw, Hex, M10 X 1.5 X 35, Ss, 2-3
Screw, Hex, M10 X 1.5 X 45, 8.8, 1-19
Screw, Hex, M10 X 1.5 X 50, 8.8, 1-19
Screw, Hex, M10 X 1.5 X 90, FI, 2-3
Screw, Hex, M5 X 0.8 X 10, Fmg, 1-25
Screw, Hex, M5 X 0.8 X 16, 8.8, 2-53, 2-55
Screw, Hex, M6 X 1.0 X 12, Ss, NI, 2-13, 2-15
Screw, Hex, M8 X 1.25 X 20, Ss, NI, 2-13, 2-15
Screw, Hex, M8 X 1.25 X 20, Ss, 2-7
Screw, Hex, M8 X 1.25 X 25, Ss, 2-7
Screw, Hex, M8 X 1.25 X 60, 8.8, 1-23
Screw, Pan, .31-18 X 0.75, 2, 1-11
Screw, Pan, #12-16 X 0.50, F/Plstc, 1-9, 2-53, 2-55, 2-57
Screw, Pan, #12-16 X 0.50, F/Plstc, 1-15
Screw, Pan, M 5 X 0.8 X 20, 4.8, 1-11
Screw, Pan, M 6 X 1.0 X 12, Ss, 1-11
Screw, Pan, M 6 X 1.0 X 20, 4.8, 1-11
Screw, Pan, M03 X 0.5 X 12, 4.8, 1-15
Screw, Pan, M04 X 0.7 X 10, Ss, 2-3
Screw, Pan, M04 X 0.7 X 20, Ss, 2-3
Screw, Pan, M04 X 0.7 X 35, Ss, 1-5, 1-7
Screw, Pan, M04x0.7 X 8, Ss, 1-39
Screw, Pan, M05 X 0.8 X 35, 4.8, 1-17
Screw, Pan, M06 X 1.0 X 40, 4.8, 1-47
Screw, Pan, M08 X 1.25 X 20, 4.8, 1-15
Screw, Pan, M4 X 0.7 X 16, 4.8, 2-7
Screw, Pan, M5 X 0.8 X 10, 4.8, 2-11, 2-13, 2-15, 2-17
Screw, Pan, M6 X 1.0 X 35, 4.8, 2-17
Screw, Set, .31-18 X 0.38, NI, 1-13
Screw, Set, #08-32 X 0.25, NI, 2-39, 2-45
Screw, Wheel Mount, 3-8
Seal, Fan, 1-3, 1-41
Seal, Felt, .19th, 4.3d 04.0h, 1-19
Seal, Foam, 1-15
Seal, Rbr, Fan, 5.6d 2.0b 1.37l, 3-3
Seal, Ring, 2-39, 2-45, 3-6, 3-7
Seal, Tank, Recvy, 1-3, 1-39
Seal, Tank, Soltn, 1-3, 1-39
Seal, 3-5
Seat, Michigan, Model V-1500, 1-11
Sensor, Level, Liquid [Magnetic], 1-39, 2-5
Sensor, Pedal Position, 1-25
Shaft, Drive Plug, 2-39, 2-45
Shaft, Idler Plug, 2-39, 2-45
Shaft, Steering, Upper, Mach, .75d 24.1l, 1-13
Shaft, W/ Sprocket, Steering, 1-13
Shell, 3-3
Shroud, Front, Mold, Ce [7080], 1-9
Shunt, 2-33
Skirt, Front, Scb, Disk, 28 Inch, 1-3, 1-31, 1-33, 2-23, 2-25
Skirt, Front, Scb, Disk, 32 Inch, 1-3, 2-31, 2-33
Skirt, Rear, Scb, Disk, 28 Inch, 1-3, 1-31, 1-33, 2-23, 2-25
Skirt, Rear, Scb, Disk, 32 Inch, 1-3, 2-31, 2-33
Skirt, 2-41, 2-47
Sleeve, .50id X .62od X 1.31l, 1-29
Sleeve, Fuse, Controller, 1-17
Sleeve, Hose, Drain, 1.5id Copp, 1-43
Sleeve, P/M, 0.437d 0.318b 1.15l 430ss, 1-9, 1-39, 1-43
Sleeve, P/M, 0.496d 0.318b 0.50l 430ss, 1-53, 2-51
Sleeve, 1-41
Spacer, .41b .63d .13l, Ss 430pm, 1-49
Spacer, .41b X .63od X .38l, 1-19, 1-47, 1-51
Spacer, Aluminum, 3-8
Spacer, Battery 1.50x4.75x7.5, 2-60, 2-61
Spacer, Battery, 2-61
Spacer, Foam, 2-60
Spacer, Spring, 2-3
Spacer, 2-3, 3-3
Spring Kit, Pedal, Foot, Replmt, 1-25
Spring, Centering, 1-51
Spring, Cmpr, .37id X Flat Wir 1.0l, 1-25
Spring, Cmpr, 0.84od .11wir 2.0l, 1-29
Spring, Cmpr, 0.98od .14wir 2.5l, 1-29
Spring, Extn, 0.38od X 0.04wir, 2.3l, 1-25
Spring, Extn, 0.50od X 0.04wir, 3.0l, 1-25
Spring, Extn, 0.50od X 0.05wir, 8.0l, 1-19
Spring, Extn, 0.62od X 0.08wir, 3.0l, 1-37, 2-3, 2-29, 2-37, 2-43, 2-49
Spring, Extn, 0.75od X 0.09wir, 2.5l, 2-3
Spring, Extn, 1.00od X 0.12wir, 5.0l, 1-51
Spring, Flt, Door, Scrbr Head, 2-39, 2-45
Spring, Tors, 2.36id .18wir 07.5coil, 2-3
Spring, Wir, 0.08d, Brake, Parking, 1-25
Spring, Wir, 0.16d, Brush Retaining, 1-5, 1-7
Spring, 3-3
Sprocket, Steering, Drive, 1-19
Sprocket, Timing, 22tooth, 0.50b, [Gi/2], 2-39, 2-45
Squeegee Assy, Side [Linatex], 1-37, 2-29, 2-37
Squeegee Assy, Side, 2-43
Stationary Fan, 3-3

CROSS REFERENCE

Strainer, Soltn, 20mesh Cyl 4.0d 8.0l, 2-5
Strap Drain Hose 170/443/E17, 1-43
Strap, Hose, Drain, 1-43
Strip, Cover, Shroud, Front, 1-9
Strip, Debris Tray, 2-41, 2-47
Strip, Retainer, Skirt, Front, 28 Inch, 1-31,
1-33, 2-23, 2-25
Strip, Retainer, Skirt, Front, 32 Inch, 2-31,
2-33
Strip, Retainer, Skirt, Rear, 28 Inch, 1-31,
1-33, 2-23, 2-25
Strip, Retainer, Skirt, Rear, 32 Inch, 2-31,
2-33
Strip, 1-39, 1-43
Support Wldt, Seat, 1-11
Switch, Key, 1-15
Switch, Press, 10psi, Spst, 2-9
Switch, Push, 12vdc 80a Spst No, 1-15
Switch, Rocker, 36vdc 05a Dpst On/N/On,
2-17
Switch, Rocker, 36vdc, 05a Dpst
On/Off/On, 1-15
Switch, Rocker, Dpst, 1-15
Switch, Rocker, Hole Plug, 1-15
Switch, Seat, Nc, 1-11
Switch, 1-15

T

Tank, Recvy, W/ Es, Afrmkt [7080], 1-39
Tank, Recvy, W/O Es, Afrmkt [7080], 1-39
Tank, Soltn, Mold, Ce [7080], 1-43
Tape, [Protective], .0080th, 1.0w, 5.0l,
1-37, 2-29, 2-37
Terminal Female Metri-Pack, 3-4
Terminal, Female, 3-3, 3-5
Tie, Cable, Nyl 07.3L .19W 1.8 Max D,
1-39
Tie, Cable, Nyl, 07.3L .19W 1.8 Max D,
2-5
Tie, Cable, Nyl, 11.4l .19w 3.0 Max D,
2-53, 2-55, 2-57
Tie, Cable, Nyl, 14.5L .30W 4.0 Max D,
1-31, 2-23, 2-31
Tie, Cable, Nyl, 14.5l .30w 4.0 Max D,
1-33, 2-25, 2-33, 2-39, 2-45
Tire Assy, Solid, 12.0 X 3.5 3.5Bc/3Bolt,
2-63
Tire Assy, Solid, 12.3x3.5 3.5bc/3bolt,
1-27
Tire, Solid, 250mm x 90mm Grey Pyu, 3-6
Tire, Solid, 250mmx90mm Gray, 3-8
Tire, Solid, 250mmx90mm Grey Pyu, 3-7
Tire, Solid, 250mmx90mm Red, 3-8
Tool, Removal, Shaft, F/222176, 2-39,
2-45
Tray, Battery, Lh, 1-47
Tray, Battery, Rh, 1-47
Tray, Debris, 32 Inch, 2-47
Tray, 2-41
Tread, Non-Skid, 02.2w 11.5l, 1-25
Tread, Non-Skid, 14.0 9.6, 1-9

Tube Assy, Bar, Spray 700mm [7100], 2-13
Tube Assy, Spray, Cyl 800mm [7100], 2-15
Tube, Pvc, Shc80, Clear, 4.0l, 2-11, 2-13,
2-15

V

Vacuum Fan, 3-3
Valve, Check, 2 Gpm 2 Psi Bm04/Bm04,
2-7
Valve, Check, 2-5
Valve, Solution, 1-45
Valve, Water, Sol, 36vdc 02pf, 2-11, 2-13,
2-15

W

Washer, 0.26b 0.72d .06, Nyl, 1-37
Washer, 0.31b 0.88d .12, Rbr, 1-51
Washer, 0.38b 1.25d .12, Neo, 2-51
Washer, 0.38b 0.88d .12, Stil, Pl, 1-11
Washer, 0.38b 1.25d .12, Neo, 1-53
Washer, 0.40b 1.12d .12, Stil, Pl, 1-9, 1-11,
1-39, 1-43
Washer, 0.47b 1.19d .03, Nyl, 3-5
Washer, 0.53b 1.88d .12, Stil, Pl, 2-51
Washer, 0.53b 1.88d .12, Stil, Pl, 1-53
Washer, Belleville, .31, 1-31, 1-33, 2-23,
2-25, 2-31, 2-33
Washer, Belleville, .38, 1-13
Washer, Flat, .25 Sae (Non-FaST Models
Only), 1-17
Washer, Flat, .25 Sae, 1-11, 1-15, 1-17
Washer, Flat, .25 Ss, 1-35, 1-37, 1-39,
1-45, 2-23, 2-27, 2-29, 2-31, 2-35,
2-37
Washer, Flat, .25 Std, 1-11, 1-13, 1-17,
1-19, 1-29, 1-39, 1-43
Washer, Flat, .31 Ss, 1-15, 1-39, 1-43, 2-5,
2-51
Washer, Flat, .34b .75d .12, Viton, 2-9
Washer, Flat, .50 Sae, 1-29
Washer, Flat, #06 Ss, 1-39
Washer, Flat, #06, 2-7
Washer, Flat, #08, 1-25
Washer, Flat, #10 Sae, 1-11, 1-17, 2-11,
2-13, 2-15
Washer, Flat, #10, 2-53, 2-55
Washer, Flat, 0.25 Fender, 1-11, 1-19
Washer, Flat, 0.25 Ss, 2-13, 2-15
Washer, Flat, 0.25 Std, 2-17
Washer, Flat, 0.26b 0.72d .06, Nyl, 2-29,
2-37
Washer, Flat, 0.31 Ss, 2-7, 2-13, 2-15
Washer, Flat, 0.35b 0.75d .04 Ss, 1-53,
2-51
Washer, Flat, 0.44b 1.00 .08, Ss, 1-29,
1-31, 1-33, 1-37, 1-51, 2-3, 2-23,
2-25, 2-29, 2-31, 2-33, 2-37, 2-41,
2-47
Washer, Flat, 0.51b 0.94d .06, Nyl, 1-49

Washer, Flat, M12, 13x24x2.5ss, 2-43,
2-49
Washer, Flt, .25 Sae, 1-9, 1-11, 1-19, 1-25,
2-53, 2-55, 2-57, 2-59
Washer, Flt, .25 Ss, 1-9, 1-33, 1-41, 1-51,
2-25, 2-33, 2-39, 2-41, 2-45, 2-47
Washer, Flt, .31 Ss, 1-9, 1-19, 1-21, 1-23,
1-39, 1-41, 1-43, 1-47, 1-49, 1-51,
1-53, 2-7, 2-39, 2-41, 2-45, 2-47
Washer, Flt, .31 Std, 1-11, 2-3, 2-53, 2-55,
2-57
Washer, Flt, .38 Std, 1-25, 2-3
Washer, Flt, .50 Sae, 1-25, 1-29, 1-31,
1-33, 2-23, 2-25, 2-31, 2-33, 2-41,
2-47
Washer, Flt, .50 Ss, 1-49
Washer, Flt, .50 Std, 1-13
Washer, Flt, #10, 1-25, 2-17
Washer, Flt, 0.25 Ss, 1-33
Washer, Flt, 25 Ss, 1-31
Washer, Lock, Int, .25, 1-17
Washer, Lock, Int, #04, 1-15
Washer, Lock, Int, #10, 2-11, 2-13, 2-15
Washer, Neo., 3-3
Washer, Spring, 3-5
Washer, Switch, Key, 1-15
Washer, Thrust, 0.61b 1.25d .06, Fgl,
1-37, 2-3, 2-29, 2-37, 2-43, 2-49
Washer, Thrust, 1-19
Washer, 1-19, 1-23
Weight, Soltn Hose, 1-45
Wheel Assy, Sqgq, 1-3, 1-53, 2-51
Wheel, 4.0d 0.87w 0.44b, 1-9, 1-39, 1-43
Wheel, Bmpr, 80d X 25w, Non-marking,
1-3, 1-53, 2-51
Wheel, Steering, 14.0d, Taper Bore, 1-13
Wire Assy, Jumper Reverse, 2-39, 2-45
Wire, 04ga 08.0l Blk .34ring / .34ring, 1-47
Wire, 04ga 12.0l Blk .34ring / .34ring, 1-47