

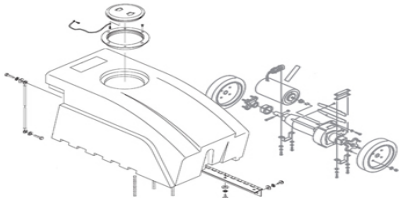

Minuteman[®]

Instruction manual



FLOOR-EQUIPMENT-PARTS.COM

Kleen Sweep 25W (625821)

Introduction

Preface

Dear customer,

We hope that the excellent qualities of the machine justify the faith you have shown in us by purchasing the product. In order to ensure that you can work with the machine safely, please read the chapter on safety before running the machine for the first time.

Your safety, and that of others, is dependent on your ability to control the machine. Therefore, read the operating manual thoroughly before operating the machine for the first time.

The operating manual contains all the important information you need to operate, maintain and service the machine. Sections of this operating manual which are relevant to safety are marked by the hazard label.

If you have any questions with regard to the machine or operating manual, you can contact your service partner at any time.

We would like to emphasize that no legal claims can be asserted in respect of any work described in this manual. Please pay attention that only original spare parts are used for any necessary maintenance and repair work. Only original spare parts can guarantee long, reliable equipment operation. We reserve the right to make technical improvements.

Valid from: January 2009

Minuteman International Inc.
14N845 U.S. Route 20
PINGREE GROVE, IL. 60140-889
U.S.A.

Intended use

The Kleen Sweep 25W is a sweeping machine conceived exclusively for sweeping up dry and wet surface areas such as production plants, warehouses, parking lots and pedestrian walkways. In addition, the Kleen Sweep 25W can also be used to remove dry dirt from carpets. Any use beyond this is regarded as improper use. The manufacturer is not considered liable for any damage resulting from improper use; the user is solely responsible for all the risks. Intended use also includes maintaining and observing the operating, maintenance and repair conditions prescribed by the manufacturer. The Kleen Sweep 25W may only be operated, serviced and repaired by personnel who are familiar with the work involved and are aware of the risks. The applicable accident prevention laws must be observed and any generally accepted health and safety directives must be maintained. The manufacturer is not deemed liable for any damage resulting from unauthorized modifications to the machine.

Introduction

Notes on warranty

The terms of the sales contract apply. Damages are not subject to warranty if they are due to non-compliance with the maintenance and service provisions. The maintenance work has to be performed by an authorized Minuteman service center and confirmed in the "Maintenance certificate" which is the warranty document.

The following is excluded from warranty: fuses, natural wear, damages caused by overload, inexpert handling and unauthorized modification of the machine. Moreover, any claim for warranty cannot be accepted if damages of the machine are caused by fitting parts or accessories without Minuteman's prior and explicit consent or by non-compliance with the maintenance instructions.

Acceptance of the machine

Upon arrival, check machine for possible damages in transit. Follow unpacking instructions on shipping pallet. Each unit has been tested and thoroughly inspected before shipment. Any damage is the responsibility of the delivery carrier who should be notified immediately.

Minuteman International Inc.
14N845 U.S. Route 20
PINGREE GROVE, IL. 60140-8893
U.S.A.

Table of content

Introduction	2	elements.	14	5.6.3	Setting the sweeping pattern	31	
Preface	2	3.2.1	Operating panel	14	5.6.4	Changing the sealing strips .	31
Intended use	2	3.2.2	Operating elements on the machine.	16	5.6.5	Changing the timing belt . . .	31
Notes on warranty	3				5.7	Dust vacuum	32
Acceptance of the machine . . .	3				5.7.1	Cleaning the filter	33
		4	Technical Data	18	5.7.2	Changing the filter	33
1 Safety Information	5	5	Maintenance and Service	20	5.8	Sweepings container	34
1.1	Safety and warning symbols .	5.1	System maintenance	20	5.8.1	Emptying the sweepings container	35
1.2	General information	5.2	Proof of Maintenance	21	5.8.2	Changing the seal	35
1.3	Operating information.	5.3	Maintenance Plan	22			
1.4	Maintenance information	5.4	Battery system	26			
1.5	Particular risks	5.4.1	Charging batteries	27			
1.6	Environmental protection	5.4.2	Total discharge signal transducer (TSG).	27			
1.7	Labels on the machine	5.4.3	Servicing the driving batteries .	27			
		5.4.4	Removing the batteries	27			
2 Starting Up	11	5.4.5	Inserting the batteries.	27			
2.1	Unpacking and assembling .	5.4.6	Disposing of batteries.	27			
2.2	Instruction.	5.5	Side brushes	28			
2.3	Initial battery charge.	5.5.1	Changing the side brush	29			
2.4	Prior to starting up	5.5.2	Setting the sweeping pattern	29			
2.5	Operation	5.6	Rotary brush.	30			
2.6	Stopping the machine	5.6.1	Cleaning the brush space . . .	31			
2.7	After completing work.	5.6.2	Changing the rotary brush . . .	31			
3 Operation	13						
3.1	Method of operation						
3.2	Operating and indicator						



EC-Declaration of Conformity 37

Safety Information

1 Safety Information

1.1 Safety and warning symbols

The following warning symbols appear in the operating manual in those sections in which your safety, the safety of the machine and environment could be affected:

Symbol	Damage to ...	Definition
Safety information 	persons or property	Safety symbol to indicate dangerous situations arising through failure to follow instructions or prescribed work procedures precisely or through ignoring them altogether.
Note 	the machine	Important information on handling the device to maintain its functioning ability.
Risk to environment 	the environment	Risks to the environment through using substances which represent a risk to health and the environment.

Safety Information

1.2 General information

- In addition to the information provided in this operating manual, all the legally applicable health and safety provisions must be observed.
- Before starting up the machine for the first time, read the operating manual supplied with it thoroughly as well as any separate manuals provided with additional or attachment devices and observe all the information during work.
- The equipment may only be operated, serviced and repaired by personnel trained by Minuteman technical experts.
- Particular attention should be paid to the information regarding safety. Technical expertise is the key to preventing errors when operating the machine and ensuring trouble-free operation.
- The operating manual must always be kept at the operating location of the machine and, as a result, should be kept in a safe place on the equipment.
- If the equipment is sold or rented out, these documents should be transferred to the new owner/operator.

The transfer should be confirmed!

- The warning labels attached to the machine provided important information concerning safe operation. Illegible or missing labels must be replaced by new ones.
- For reasons of safety, always use original spare parts.

1.3 Operating information

- Before starting the machine up for the first time, the battery to be used must be fully charged, properly, by implementing the initial battery charge routine. Please pay attention to the operating manual provided with the charging unit as well as the manual from the battery manufacturer. Minuteman assumes no liability for damage to the battery caused by a fault when the battery is charged for the first time.
- Check the operational safety of the machine each time before starting it up! Clear any faults immediately!
- Before starting work, the operator must be fully familiar with all adjustment, operating and control elements as well as their respective function! It is too late to do this when

the machine is actually in operation!

- Always wear heavy duty, non-slip footwear when working with the machine.
- The machine may only be used on those surfaces which have been approved by the contractor or person appointed by him.
- When using the machine, it is essential to pay attention to third parties, especially children.
- Accelerate the machine immediately after switching on the brush head drive, otherwise imprints of the brush could be produced on the floor.
- The machine is not suitable for clearing up hazardous, flammable or explosive fluids, dust or substances.
- It is forbidden to use the machine in potentially explosive atmospheres.
- The side brush must be raised in order to transport the machine.
- The machine has been conceived for use on level surfaces with a maximum gradient of 2%.

1.4 Maintenance information

- Operating personnel must complete the necessary daily and weekly maintenance work. All other maintenance

Safety Information

nance work must be completed at your local Minuteman service center.

- The maintenance work and maintenance intervals prescribed in the operating manual must be adhered to.
- Suitable tools must be used for cleaning and maintenance work.
- The machine must be inspected by a recognized technical expert in respect of operational safety, within the terms of the applicable accident prevention laws, at reasonable intervals (we recommend at least once a year) and following modification or repairs .
- Spare parts must comply with the minimum technical requirements stipulated by the manufacturer! This is ensured by the use of original spare parts.
- The machine must be switched off prior to cleaning or servicing it or to replacing parts. The drive bar must be out of operation!
- Always disconnect the battery plug before starting any work on the electrical installation.
- When working in the area of the raised hood, it must be hinged open fully to prevent it being knocked shut

or further open and down unintentionally.

- It is not permitted to clean the machine with a pressure washer or steam blaster.
- It is not permitted to use aggressive and corrosive cleaning agents.
- Allow the machine to dry after being cleaned, e.g. over the weekend.
- Only start the machine up when all the safety equipment has been installed and brought to its protecting position.

1.5 Particular risks

Electronics

- In the case of defects in the electrical installation, switch the machine off immediately and clear the fault.
- Work on the electrical equipment may only be carried out by electricians who have received the necessary training and in accordance with the electrical engineering regulations.
- The machine's electrical equipment must be inspected/checked at regular intervals. Defects, such as loose connections and cable damage, must be rectified immediately.

Batteries

- Observe the information in the operating manual provided by the battery manufacturer.
- It is possible that sparking will occur when connecting the batteries.
- Batteries may only be handled and changed by properly skilled maintenance personnel.
- The machine has been set up for operation using maintenance-free batteries. If other battery types are used, the machine must be set up for use with them by an authorized Minuteman service center.
- Never lay any metallic objects or tools on batteries - risk of short circuit!
- For further safety information, refer to supplementary sheet 88-60-2556 - notes on driving batteries.

Safety Information

1.6 Environmental protection

- A certain factual expertise is required in order to use substances which could represent a risk to health and the environment.
- Observe the applicable laws and local regulations when disposing of waste.
- Used batteries with the recycling symbol contain reusable commodities. In accordance with symbol with the crossed out bin, these batteries must not be disposed of in domestic waste. The return and recycling of batteries must be agreed on with Minuteman authorized dealers in accordance with § 8 BattV (Battery Directive)!

Safety Information

1.7 Labels on the machine

The following safety and warning labels are attached to the machine where easily legible. Missing or illegible labels must be replaced immediately.

Company logo (Fig. 1/1)

Minuteman[®]

Rating plate (Fig. 1/2)



Filter shaker (Fig. 1/3)



Read and observe the operating manual (Fig. 1/4)



Maximum permissible gradient (Fig. 1/5)



Wear compensator for side brush (Fig. 1/6)



Wear compensator for rotary brush (Fig. 1/7)



Safety Information

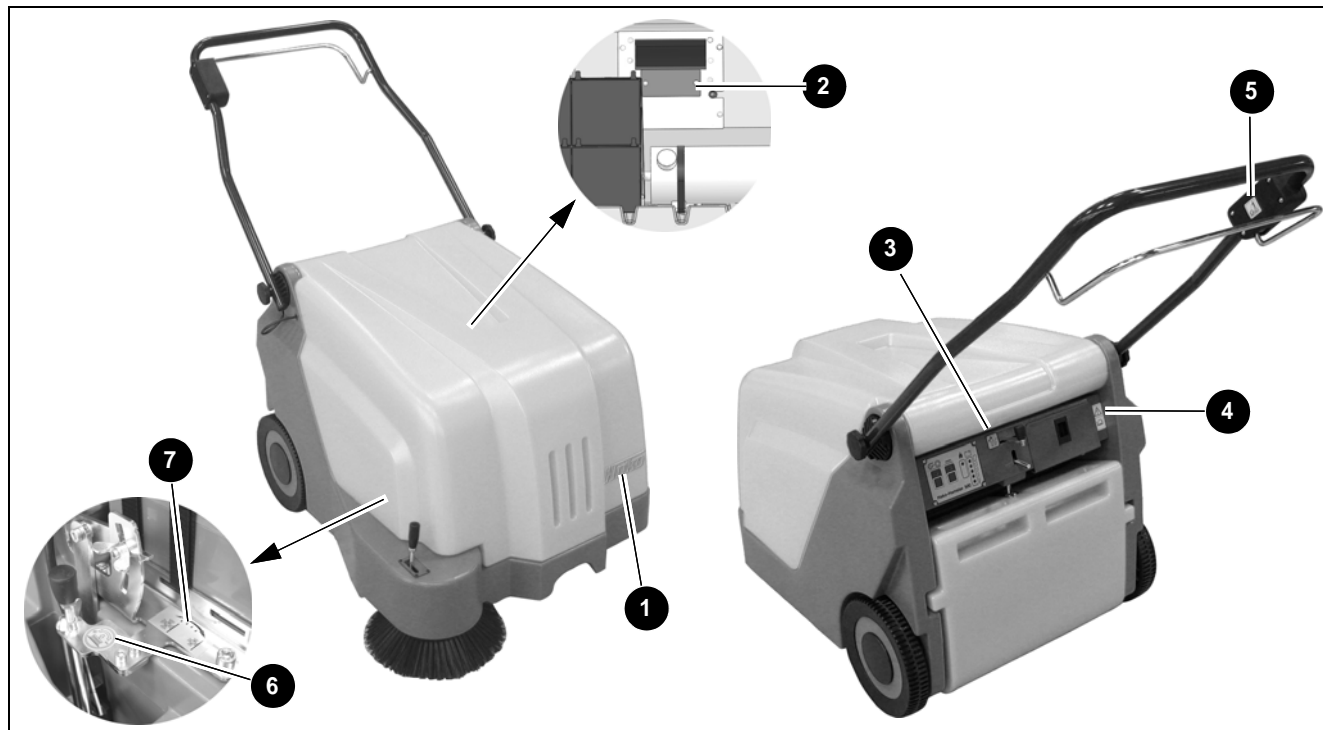

Fig.1

Starting Up

2 Starting Up

2.1 Unpacking and assembling

Open the box, two people are required to remove the machine from the protective foil and place it on the floor.

1. Fix the side brush (Fig. 2/1) to the axle of the side brush drive using the wing bolt and washer supplied.
2. Loosen the two knurled screws (Fig. 2/2) holding the handle a few revolutions until the handle can be raised and positioned. Set the handle to a height comfortable for the user and then tighten the knurled screws.
3. Loosen the locking bolt holding the hood (Fig. 2/3) and pivot the hood open.
4. Fix the disassembled cable lug (Fig. 2/4) to the corresponding battery contact. It is possible that sparking will occur when connecting the batteries!
5. Close the hood and lock in place with the bolt.
6. The Kleen Sweep 25W is now ready to operate.

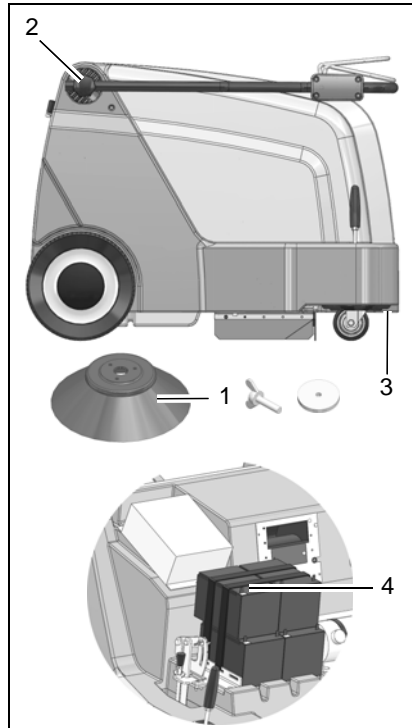

Fig.2

2.2 Instruction

Instructions to operators are required before putting the machine into service. Only technicians from your local, authorized Minuteman dealer are allowed to provide initial instruction on how to use the machine. The manufacturing plant notifies the dealer immediately after delivering the machine and the dealer will contact you to arrange a date for providing the initial instruction.

2.3 Initial battery charge



Before starting the machine up for the first time, the batteries to be used must be fully charged, properly, by implementing the initial battery charge routine. Please pay attention to the operating manual provided with the charging unit as well as the manual from the battery manufacturer. Minuteman assumes no liability for damage to the battery caused by a fault when the battery is charged for the first time.

Starting Up

2.4 Prior to starting up

Carry out the following checks before starting the machine:

1. Check the charge status of the batteries.
2. Check the levels of wear on the rotary brush and side brush.
3. Check the fill level of the sweepings container.

2.5 Operation

Please read the Safety Information in Chapter 1. Before switching the machine on, ensure that the drive bar (Fig. 3/3) on the handle has not been actuated.

1. Switch the machine on using the (Fig. 3/1) button: rotary brush drive, dust vacuum and side brush drive are ready to operate.
2. Lower the side brush to its working position using the lever (Fig. 3/4). When working without the side brush: do not lower the side brush and press the button (Fig. 3/2) for the side brush once. The green control lamp goes out.
3. Actuate the drive bar (Fig. 3/3) on the handle: the machine starts to work.



Start work immediately after actuating the drive bar, otherwise imprints could be produced on the floor. Release the drive bar when driving over thresholds.

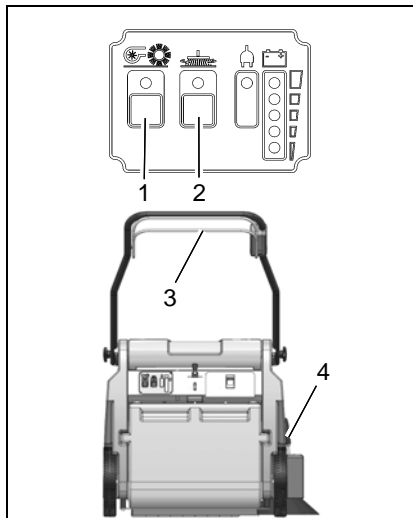

Fig.3

2.6 Stopping the machine

When the drive bar is released, the rotary brush drive, dust vacuum and side brush drive switch off automatically.

2.7 After completing work

1. Drive to an appropriate maintenance area.
2. Stop the machine. Raise the side brush to its idle position and switch the machine off.
3. Actuate the filter shaker.
4. Empty the sweepings container.
5. Check the brush space for accumulations of dirt.
6. Check the charge status of the batteries.



It is not permitted to clean the machine with a pressure washer or steam blaster.

3 Operation

3.1 Method of operation

The Kleen Sweep 25W is a machine designed to sweep and clean waste from hard floors and carpets.

The side brush (Fig. 4/1) sweeps the dirt from corners to a position in front of the rotary brush (Fig. 4/2). The rotary brush sweeps the larger particle dirt overhead into the sweepings container (Fig. 4/3). The finer dust picked up is drawn up by the suction turbine, fed into the filter system (Fig. 4/4) and filtered out. Only dust-free air is fed back into the ambient air.

The machine is equipped with maintenance-free batteries (Fig. 4/5), a specially adapted, fully automatic battery charger (Fig. 4/6) and a total discharge signal transducer to protect it against total discharge.



Please refer to the spare parts catalogue on our internet site at www.Minuteman.com for accessories, such as brushes and rotary brushes.

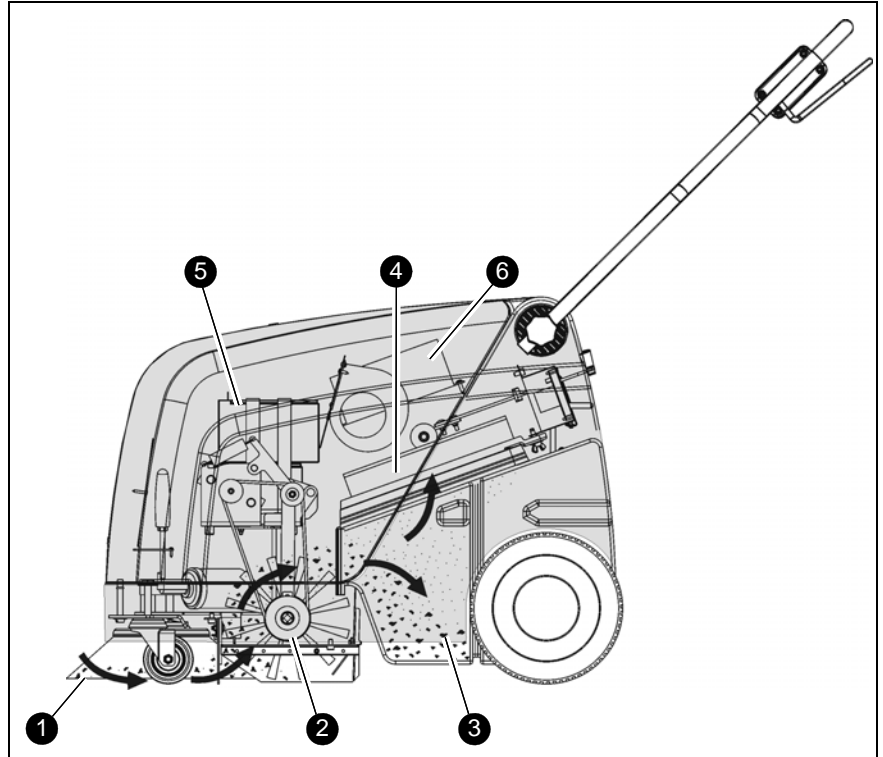

Fig.4

Operation

3.2 Operating and indicator elements

3.2.1 Operating panel

- 1 Control lamp for rotary brush drive, side brush drive and suction turbine
- 2 ON/OFF button for rotary brush drive, side brush drive and suction turbine
- 3 Control lamp for side brush drive
- 4 ON/OFF button for side brush drive
- 5 Control lamp for battery charger operation
- 6 Charge control indicator
- 7 Drive bar

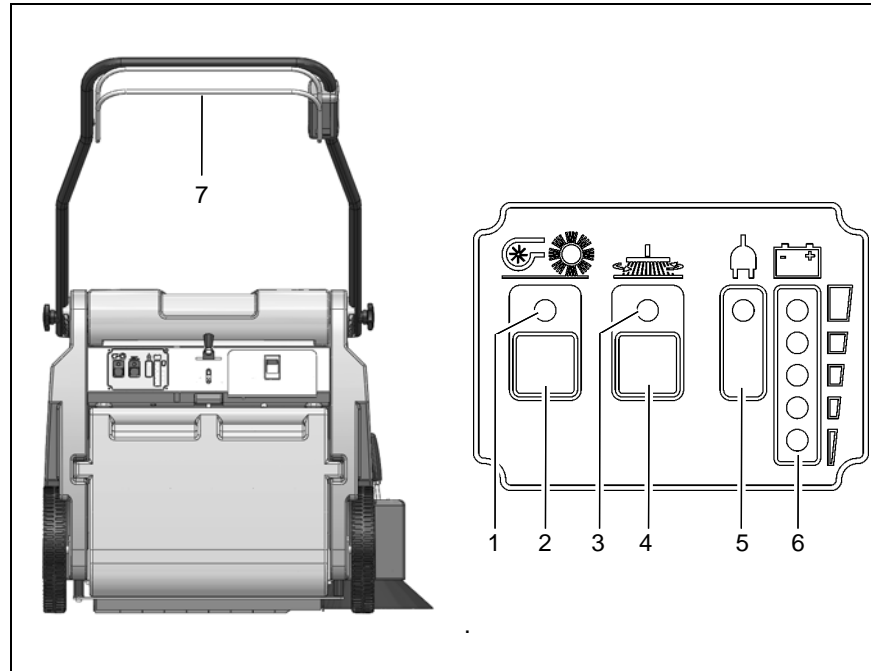

Fig.5

Operation

Control lamp for rotary brush drive, side brush drive and suction turbine (Fig. 5/2)

The green control lamp indicates that the rotary brush drive and suction turbine are ready to operate. If the rotary brush or suction turbine are overloaded, a safety shutdown is triggered and the control lamp flashes.

ON/OFF button for rotary brush, side brush and suction turbine (Fig. 5/1)

The button activates the rotary brush drive, side brush drive and suction turbine so they are ready to operate.

The side brush drive can be switched off separately. The suction turbine cannot be switched off separately which prevents the dust vacuum being activated by accident.



To prevent unauthorized use of the machine, switch the machine off using the button (Fig. 5/1).

Control lamp for side brush drive (Fig. 5/4)

The green control lamp indicates that the side brush drive is ready to operate. If the side brush is overloaded, a safety shutdown is triggered and the control lamp flashes.

ON/OFF button for side brush drive (Fig. 5/3)

The button can be used to switch off the side brush drive independently of the rotary brush drive and to activate it for use again.

Control lamp for battery charger operation (Fig. 5/5)

This control lamp indicates that the batteries are being charged.

Charge control indicator (Fig. 5/6)

During the charging process, the machine's electronics system controls the machine is not switched on inadvertently and indicates the charge status. The battery charge status is indicated by 4 green and 1 red LED.

The battery voltage is depicted in 5 levels:

≥ 25.1 V = all green LEDs on
≥ 24.5 V = bottom 3 green LEDs on
≥ 23.9 V = bottom 2 green LEDs on
≥ 22.7 V = bottom green LED on
< 22.7 V = red battery LED flashes

Drive bar (Fig. 5/7)

The drive bar switches all the drives which are ready to operate on or off. The drive bar serves to prevent damage. If the drive bar is released during operation, all the drives are switched off.

Operation

3.2.2 Operating elements on the machine

- 1 Knurled screws for the handle
- 2 Shaking device lever
- 3 Sweepings container lock
- 4 Side brush lever
- 5 Charger cable flap

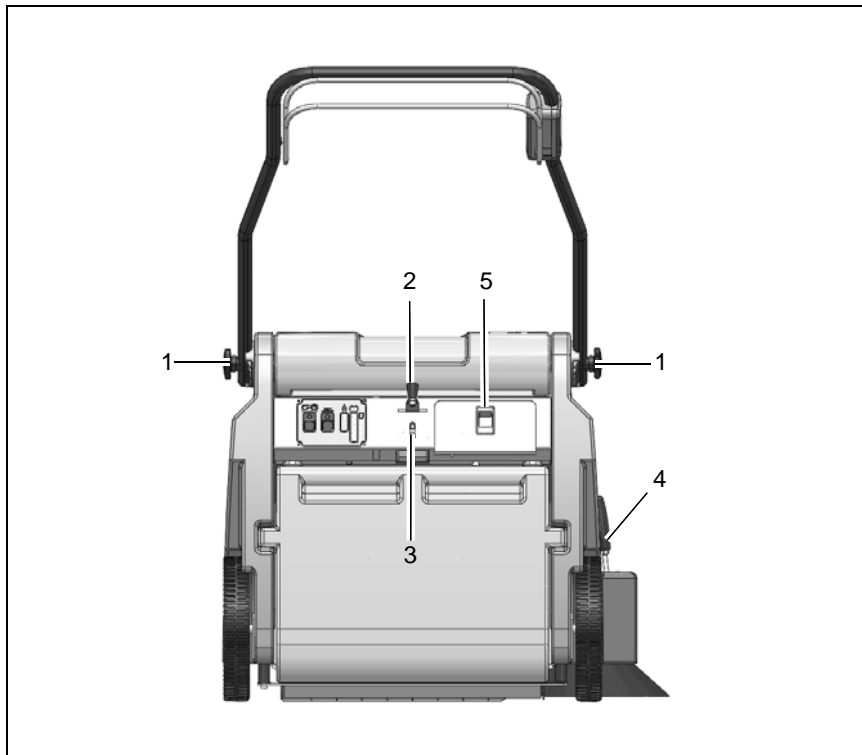

Fig.6

Operation

Knurled screws for handle (Fig. 6/1)

The two knurled screws enable the handle to be adjusted to a comfortable height for the user.

Shaking device lever (Fig. 6/2)

In order to clean the filter in the dust vacuum, switch the shaking device lever several times quickly to the left and right.

Sweepings container lock (Fig. 6/3)

Pull the lock lever up in order to remove the sweepings container.

Side brush lever (Fig. 6/4)

Use the lever to lower or raise the side brush.

Charger cable flap (Fig. 6/5)

The battery charger cable is located behind the flap to the right beside the operating panel. Pull the lock downwards to open the flap.

Technical Data

4 Technical Data

Machine length	cm	80
Machine height (handle folded)	cm	60
Machine width	cm	70
Working width	cm	60
Load capacity, sweeper's container	kg	25
Rotary brush width	cm	40
Rotary brush diameter	cm	19
Area coverage, theoretic	m ² /h	2400
Sweeper's container volume	Liter	40
Filter surface	m ²	1,2
Nominal voltage	V	24
Power consumption, rotary brush drive	W	210
Power consumption, side brush drive	W	48
Power consumption, suction turbine drive	W	60
Weight without batteries	kg	36
Weight with batteries	kg	51

Technical Data

<p>Noise emission value</p> <p>Sound power level (L_{WA}) measured according to DIN EN 60335-2-72 under maximum working conditions:</p> <p>The sound pressure level (L_{pA}) (at the ear of the operator) measured according to DIN IEC 60335-2-72 under normal working conditions:</p> <p>Measurement inaccuracy (K_{pA}):</p>	<p style="text-align: center;">dB (A)</p> <p style="text-align: center;">dB (A)</p> <p style="text-align: center;">dB (A)</p>	<p style="text-align: center;">62</p> <p style="text-align: center;">78</p> <p style="text-align: center;">2</p>
<p>Vibration</p> <p>The weighted effective value of acceleration, measured in accordance with DIN EN ISO 5349, to which the upper parts of the body (hand-arm) are exposed under normal working conditions:</p>	<p style="text-align: center;">m/s²</p>	<p style="text-align: center;">< 2.5</p>

5 Maintenance and Service

General information



It is essential to pay attention to the information in Chapter "Safety Information" before completing any service or maintenance work!

By adhering to the maintenance work recommended by us, you can be sure that the machine is always ready to be put into operation.

Maintenance and repair work necessary on a daily and weekly basis can be carried out by an operator trained to complete the work, all other Minuteman system maintenance may only be completed by personnel who are correspondingly qualified and trained. Please contact your nearest Minuteman service center or Minuteman authorized dealer. Failure to observe this annuls any rights to claims under the terms of guarantee in respect of resulting damage or consequential damage.

Always specify the serial number in the case of inquiries and spare parts orders, refer to section 1.7 - Rating plate.

5.1 Minuteman system maintenance

The Minuteman system maintenance:

- ensures that the Minuteman machine is always ready for operation (preventive maintenance),
- minimizes operating costs, maintenance and repair costs,
- ensures the machine has a long service life.

Minuteman system maintenance provides individual modules explaining the special technical work to be carried out and prescribes the intervals at which the work should be performed. Parts to be replaced for the individual maintenance tasks are defined and provided in spare parts kits.

Minuteman system maintenance, customer

Work to be carried out by the customer according to the service and maintenance instructions in the operating manual (daily and weekly). The driver/operator receives proper instruction when the machine is delivered.

Minuteman system maintenance I:

(every 125 operating hours)

Completed by technical experts from an

authorized Minuteman service center in accordance with the specific machine system maintenance using spare parts kits.

Minuteman system maintenance II:

(every 250 operating hours)

Completed by technical experts from an authorized Minuteman service center in accordance with the specific machine system maintenance using spare parts kits.

Minuteman system maintenance III/S:

(every 500 operating hours, safety check)

Completed by technical experts from an authorized Minuteman service center in accordance with the specific machine system maintenance using spare parts kits. Completion of all legally prescribed, safety-related tests in accordance with UVV-BGV-TÜV-VDE

Maintenance and Service

5.2 Proof of Maintenance

<p style="text-align: center;">Handover</p> <p>Upgrading Test drive Handover to customer Instruction completed on: at _____ operating hours</p>	<p style="text-align: center;">System Maintenance I 125 operating hours Workshop Stamp</p> <p>completed on: at _____ operating hours</p>	<p style="text-align: center;">System Maintenance II 250 operating hours Workshop Stamp</p> <p>completed on: at _____ operating hours</p>	<p style="text-align: center;">System Maintenance I 375 operating hours Workshop Stamp</p> <p>completed on: at _____ operating hours</p>
<p style="text-align: center;">System Maintenance III/S 500 operating hours Workshop Stamp</p> <p>completed on: at _____ operating hours</p>	<p style="text-align: center;">System Maintenance I 625 operating hours Workshop Stamp</p> <p>completed on: at _____ operating hours</p>	<p style="text-align: center;">System Maintenance II 750 operating hours Workshop Stamp</p> <p>completed on: at _____ operating hours</p>	<p style="text-align: center;">System Maintenance I 875 operating hours Workshop Stamp</p> <p>completed on: at _____ operating hours</p>
<p style="text-align: center;">System Maintenance III/S 1000 operating hours Workshop Stamp</p> <p>completed on: at _____ operating hours</p>	<p style="text-align: center;">System Maintenance I 1125 operating hours Workshop Stamp</p> <p>completed on: at _____ operating hours</p>	<p style="text-align: center;">System Maintenance II 1250 operating hours Workshop Stamp</p> <p>completed on: at _____ operating hours</p>	<p style="text-align: center;">System Maintenance I 1375 operating hours Workshop Stamp</p> <p>completed on: at _____ operating hours</p>

Maintenance and Service

5.3 Maintenance Plan

Minuteman routine maintenance

The following maintenance work must be completed by the customer at the intervals stipulated.

Activity	Interval	
	Daily	Weekly
Check the battery charge; recharge if necessary	o	
Empty the sweeper's container	o	
Clean the brush space	o	
Check the filter in the dust vacuum; clean, if necessary	o	
Check the rotary brush and side brush; clean, if necessary	o	
Check the sweeping pattern; readjust, if necessary		o
Check the sealing strips on the rotary brush for signs of wear; clean, if necessary		o
Check the gasket on the sweeper's container		o
Check the function of the suction turbine		o
Check the sweeper's container lock		o
Test drive and function test		o

Maintenance and Service

Minuteman routine maintenance I

The following maintenance work must be completed by an authorized Minuteman service center.

Activity	Interval
	Every 125 operating hours
Check the rotary brush and side brush; change, if necessary	o
Check the sweeping pattern; readjust, if necessary	o
Check the gasket on the filter supporting frame; change, if necessary	o
Check the function of the drive bar	o
Check the condition of the tires	o
Test drive and function test	o

Maintenance and Service

Minuteman routine maintenance II

The following maintenance work must be completed by an authorized Minuteman service center.

Activity	Interval
	Every 250 operating hours
All maintenance work in accordance with Minuteman routine maintenance I	o
Check the function of the charger	o
Check the function of the operating panel	o
Check the steering castor in respect of its running surface and bearing play; change, if necessary	o
Check the filter in the dust vacuum; change the filter if necessary	o
Check the running surface of the wheels; change, if necessary	o
Check the sweepings container lock	o
Test drive and function test	o

Maintenance and Service

Minuteman routine maintenance III/S (safety check)

The following maintenance work must be completed by an authorized Minuteman service center at least once a year.

Activity	Interval
	Every 500 operating hours
All maintenance work in accordance with Minuteman routine maintenance II	o
Check the suction turbine for signs of wear; change, if necessary	o
Clean the side brush drive from coal dust, check the carbon brushes run smoothly and for signs of wear; change the carbon brushes, if necessary	o
Clean the rotary brush drive from coal dust, check the carbon brushes run smoothly and for signs of wear; change the carbon brushes, if necessary	o
Check the rotary brush timing belts fro signs of wear; change, if necessary	o
Check the rotary brush bearing in terms of play and for signs of wear; change, if necessary	o
Check the wheel bearings in terms of play and for signs of wear; change, if necessary	o
Test drive and function test	o

Maintenance and Service

5.4 Battery system

- 1 Battery indicator for charger
- 2 Charge control indicator
- 3 Charger
- 4 Flap for charger mains power cable
- 5 Connection cable
- 6 Lashing straps
- 7 Batteries
- 8 Hood
- 9 Connection plan



Batteries may only be handled and changed by properly skilled maintenance personnel.

The charge control indicator (Fig. 7/2) indicates the charge status of the batteries during operation. When the batteries are discharged, the red LED flashes. The machine functions are restricted. Charge the batteries immediately!

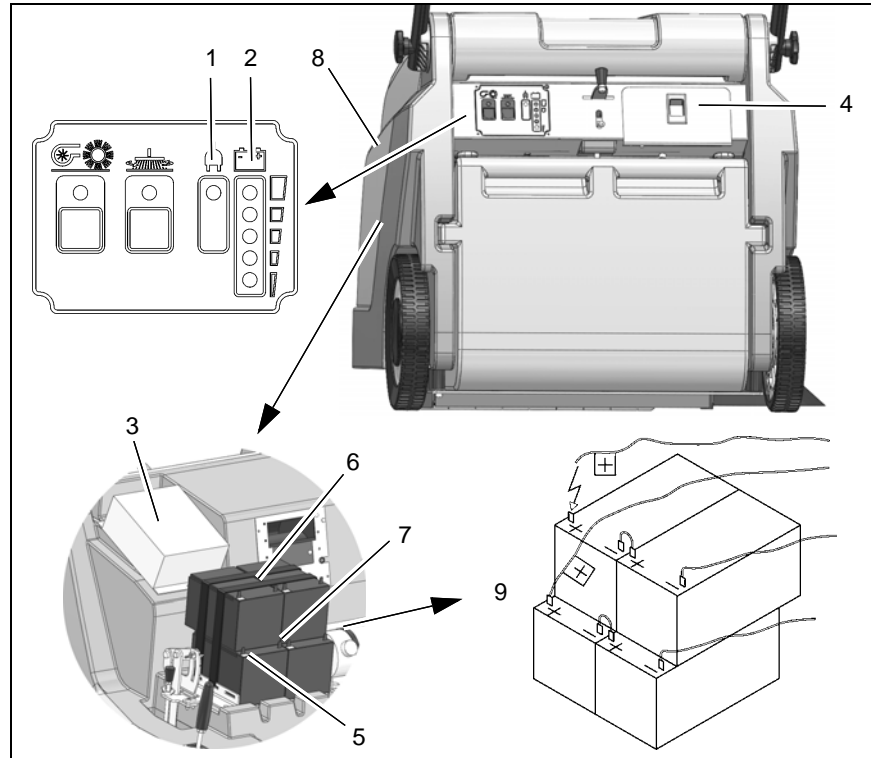

Fig.7

Maintenance and Service

5.4.1 Charging batteries

The charge control indicator (Fig. 7/2) indicates the charge status of the batteries during operation. The batteries must be charged immediately the red LED lights up. The batteries (Fig. 7/7) are charged using the integrated battery charger (Fig. 7/3). The charger is connected by means of the power cable (Fig. 7/4). While the battery is being charged, the battery indicator on the charger (Fig. 7/1) lights up.



Before starting the machine up for the first time, the batteries to be used must be fully charged, properly, by implementing the initial battery charge routine. Minuteman assumes no liability for damage to the battery caused by a fault when the battery is charged for the first time.

5.4.2 Total discharge signal transducer (TSG)

The machine is equipped with a total discharge signal transducer to protect the batteries against total discharge. The total discharge signal transducer is integrated in the electronics. If other

batteries are used, the total discharge signal transducer must be adjusted.



The total discharge signal transducer may only be adjusted by an authorized Minuteman service center.

5.4.3 Servicing the driving batteries

Never leave discharged batteries lying around; recharge them immediately! For information on servicing driving batteries, refer to operating manual 88-60-2556.

5.4.4 Removing the batteries

1. Park the machine on a level area of floor.
2. Switch off the machine.
3. Loosen the locking bolt holding the hood (refer to Figure 3) and pivot the hood open.
4. Slacken the lashing straps (Fig. 7/6).
5. Disconnect the connection cable (Fig. 7/5) from the batteries and remove the batteries.

5.4.5 Inserting the batteries



Only the special batteries approved by Minuteman may be installed at the prescribed

position.

1. Install the two lower batteries in the battery holder in accordance with Figure 6.
2. Lay the rubber mat on the batteries.
3. Place the other two batteries on the rubber mat.
4. Tighten the lashing straps (Fig. 7/6).
5. Connect the battery poles to the connection cables enclosed in the accessories kit in accordance with the connection plan (Fig. 7/9).

It is possible that sparking will occur when connecting the batteries! Check a firm fit!

6. Close the hood (Fig. 7/8) and lock in place with the locking bolt on the frame.

5.4.6 Disposing of batteries

Used batteries with the recycling symbol contain reusable commodities. In accordance with symbol with the crossed out bin, these batteries must not be disposed of in domestic waste. Return and recycling must be agreed on with Minuteman's authorized dealer in accordance with § 8 BattV (Battery Directive)!

5.5 Side brushes

- 1 Side brushes
- 2 Wing bolt
- 3 Carrier
- 4 Hood
- 5 Adjusting bolt
- 6 Counternut
- 7 Locking bolt

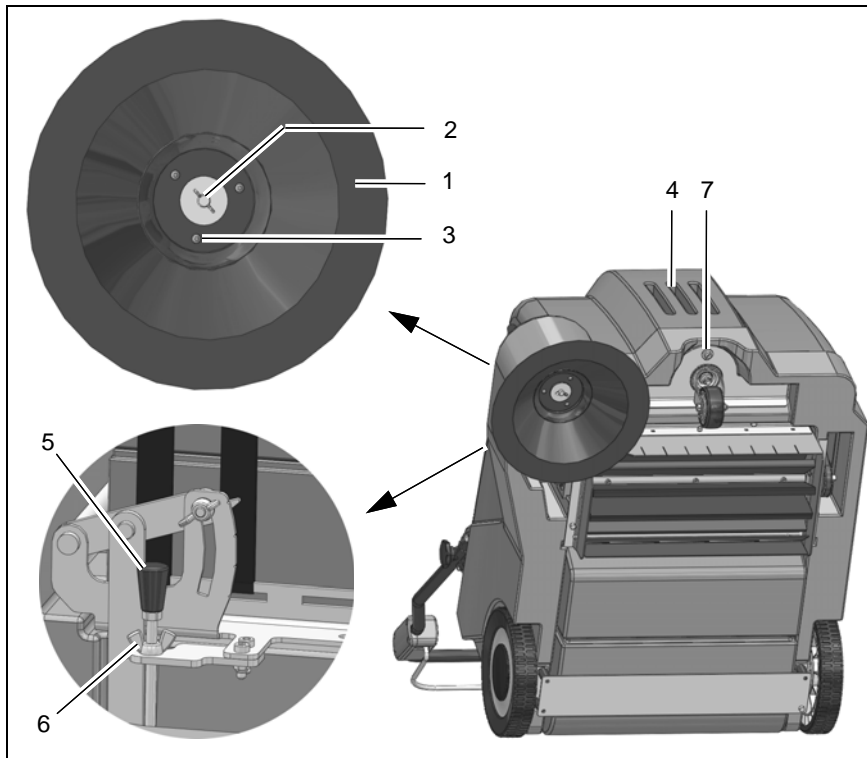

Fig.8

Maintenance and Service

5.5.1 Changing the side brush

Check the side brush (Fig. 8/1) weekly and change in the case of wear.

1. Switch the machine off and lay it on its side.
2. Remove the wing bolt (Fig. 8/2) with the washer from underneath the side brush (Fig. 8/1).
3. Pull the side brush off.
4. Position the new side brush on the carrier (Fig. 8/3) and fix in place with the wing bolt and washer.

5.5.2 Setting the sweeping pattern

In the case of brush wear, and after changing the side brush (Fig. 8/1), re-adjust the sweeping pattern.

1. Switch the machine off, unscrew the locking bolt (Fig. 8/7) and open the hood (Fig. 8/4).
2. Loosen the counternut (Fig. 8/6) and adjust the sweeping pattern by turning the adjusting bolt (Fig. 8/5) clockwise and counterclockwise so that it touches the floor.
3. Tighten the counternut again and close the hood.
4. Switch the machine on and allow the side brush to run while standing still for a short time.

5. Switch the machine off, raise the front a little and pull it back.
6. Check the sweeping pattern, comparing it with a clock viewed driving forward. When set correctly, the sweeping pattern must make an impression on the floor between approx. 10:00 and 4:00 o' clock.



7. Repeat the process, if necessary, until the sweeping pattern is set correctly.
8. Close the hood (Fig. 8/4) and screw the locking bolt (Fig. 8/7) back in.

Maintenance and Service

5.6 Rotary brush

- 1 Rotary brush
- 2 Fillister head self-tapping screws
- 3 Rotary brush segment
- 4 Sealing strips
- 5 Sweeping pattern adjusting lever
- 6 Timing belt
- 7 Hood
- 8 Locking bolt

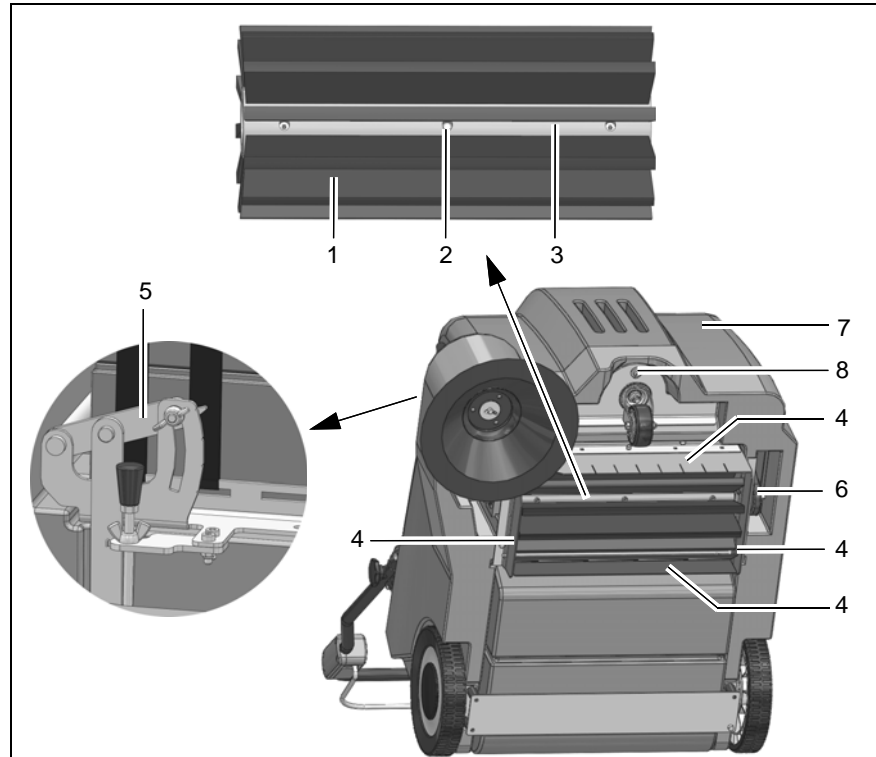

Fig.9

5.6.1 Cleaning the brush space

The brush space with rotary brush (Fig. 9/1) and gaskets (Fig. 9/4) must be checked daily for signs of dirt and cleaned, if necessary.

5.6.2 Changing the rotary brush

The rotary brush (Fig. 9/1) must be checked weekly and changed in the case of wear.

1. Switch the machine off and lay it on its side.
2. Loosen the six fillister head screws (Fig. 9/2) in the rotary brush and remove the two roller segments.
3. Install the two new roller segments and fix in place with the fillister head screws.
4. After changing the rotary brush, re-adjust the sweeping pattern as necessary.

5.6.3 Setting the sweeping pattern

In the case of brush wear, and after changing the rotary brush (Fig. 9/1), re-adjust the sweeping pattern.

1. Switch the machine off, unscrew the locking bolt (Fig. 9/8) and open the hood (Fig. 9/7).
2. Loosen the wing nut on the adjusting lever (Fig. 9/6) and adjust the

sweeping pattern using the adjusting lever (Fig. 9/5) by pivoting it up and down until it touches the floor.

3. Tighten the wing nut again and close the hood.
4. Switch the machine on and allow the rotary brush to run while standing still for a short time.
5. Switch the machine off, raise the front a little and pull it back.
6. When adjusted correctly, there must be an approx. 50 mm wide sweeping pattern on the floor which has parallel sides.
7. Repeat the process, if necessary, until the sweeping pattern is set correctly.
8. Close the hood (Fig. 9/7) and screw the locking bolt (Fig. 9/8) back in.

5.6.4 Changing the sealing strips

The four sealing strips (Fig. 9/4) must be checked weekly and changed in the case of wear.

1. Switch the machine off and lay it on its side.
2. Remove all four sealing strips (Fig. 9/2) with holders.
3. Loosen the screws in the holders and remove the damaged sealing

strips.

4. Fix the new sealing strips on the holders and reinstall them.
5. Adjust the sealing strips so that they touch the floor lightly.

5.6.5 Changing the timing belt

The timing belt (Fig. 9/6) must be checked every 500 operating hours and changed in the event of wear.

1. Switch the machine off, unscrew the locking bolt (Fig. 9/8) and open the hood (Fig. 9/7).
2. Slacken the timing belt (Fig. 9/6) using the tension pulley and remove the belt.
3. Slacken the tension pulley and install the new timing belt. The timing belt is automatically tensioned by means of a tension spring.
4. Close the hood (Fig. 9/7) and screw the locking bolt (Fig. 9/8) back in.

5.7 Dust vacuum

- 1 Filter
- 2 Sealing strip
- 3 Filter support frame
- 4 Shaking device
- 5 Wing bolts
- 6 Holder

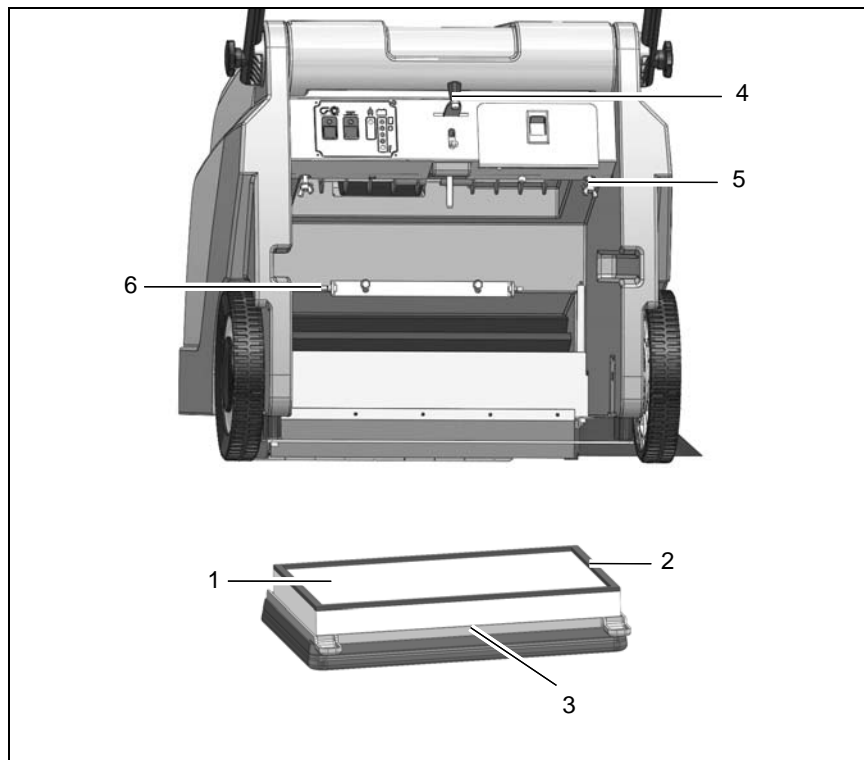

Fig.10

Maintenance and Service

5.7.1 Cleaning the filter

Clean the filter (Fig. 10/1) in the dust vacuum as necessary using the shaking device (Fig. 10/4). In the case of extreme accumulation of dirt, clean the filter as follows:

1. Switch the machine off and remove the sweeper's container.
2. Loosen the wing bolts (Fig. 10/5). Pivot the filter support frame (Fig. 10/3) down and remove it.
3. Remove the filter from the filter support frame.
4. Beat the filter clean or use a vacuum cleaner. Be careful not to damage the filter ribs!
5. Insert the correct side of filter in the filter support frame. The sealing strip (Fig. 10/2) must point towards the suction turbine!
6. Hook the filter support frame in the holder (Fig. 10/6) and fix in place with the wing bolts.
7. Reinstall the sweeper's container.

5.7.2 Changing the filter

Check the filter (Fig. 10/1) every 250 operating hours for signs of wear and change it as necessary.

1. Switch the machine off and remove

the sweeper's container.

2. Unscrew the wing bolts (Fig. 10/5). Pivot the filter support frame (Fig. 10/3) down and remove it.
3. Remove the filter from the filter support frame.
4. Insert the correct side of the new filter in the filter support frame. The sealing strip (Fig. 10/2) must point towards the suction turbine!
5. Hook the filter support frame in the holder (Fig. 10/6), if necessary, and fix in place with the wing bolts.
6. Reinstall the sweeper's container.

5.8 Sweeper's container

- 1 Sweeper's container
- 2 Locking mechanism
- 3 Seal
- 4 Handle

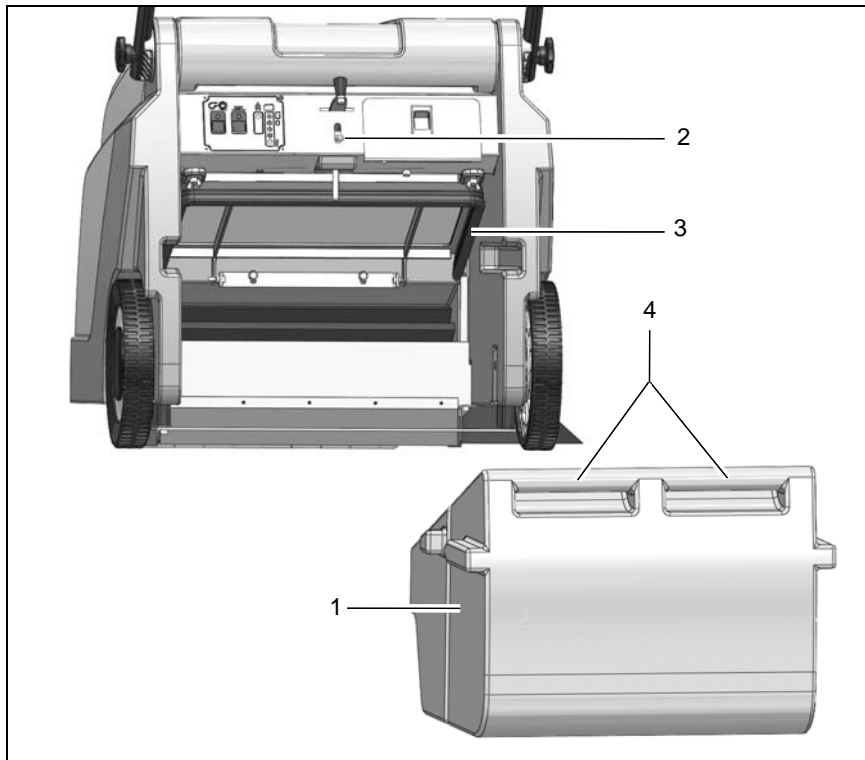

Fig.11

Maintenance and Service

5.8.1 Emptying the sweepings container

Check the fill level of the sweeper's container (Fig. 10/1) at regular intervals (max. load capacity 25 kg) and empty as necessary.

1. Switch the machine off and pull the locking mechanism (Fig. 10/2) on the sweeper's container (Fig. 10/1) upwards.
2. Pull the sweeper's container to the rear out of the machine using the handle (Fig. 10/4) and dispose of the waste according to the applicable environmental laws.
3. Reinstall the sweeper's container and press it against the locking mechanism until it audibly latches into place.

5.8.2 Changing the seal

Check the seal (Fig. 10/3) weekly for signs of wear and change it as necessary.

1. Switch off the machine and pull the locking mechanism (Fig. 10/2) on the sweeper's container (Fig. 10/1) upwards.
2. Pull the sweepings container (Fig. 10/3) to the rear and out of the ma-

chine using the handle (Fig. 10/4).

3. Pull the seal on the sweeper's container from the filter support frame. Install a new seal.
4. Reinstall the sweeper's container and press it against the locking mechanism until it audibly latches into place.

Maintenance and Service

EC-Declaration of Conformity (according to Directive 98/37/EC)

Minuteman International Inc.
14N845 U.S. Route 20
PINGREE GROVE, IL. 60140-8893
U.S.A.

declare under our sole responsibility,
that the product

Minuteman Kleen Sweep 25W
Type: 6258

to which this declaration relates, corresponds to the relevant basic safety and health requirement of the Directive 98/37/EC, and to the requirements of the other relevant Directives:

89/336/EEC.

For the relevant implementation of the safety and health requirements mentioned in the Directives, the following standard (s) and / or technical specification (s) has (have) been respected:

DIN EN 60335-2-72
DIN EN 61000-6-2
DIN EN 61000-6-3

Bad Oldesloe, 21.01.2009

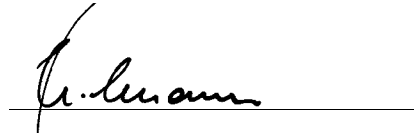
A handwritten signature in black ink, appearing to read 'B. Heilmann', is written over a horizontal line.

Bernd Heilmann
Managing director

Minuteman International Made Simple Commercial Limited Warranty

Minuteman International, Inc. warrants to the original purchaser/user that this product is free from defects in workmanship and materials under normal use. Minuteman will, at its option, repair or replace without charge, parts that fail under normal use and service when operated and maintained in accordance with the applicable operation and instruction manuals.

All warranty claims must be submitted through and approved by factory authorized repair stations.

This warranty does not apply to normal wear, or to items whose life is dependent on their use and care, such as belts, cords, switches, hoses, rubber parts, electrical motor components or adjustments. Parts not manufactured by are covered by and subject to the warranties and/or guarantees of their manufacturers. Please contact Minuteman for procedures in warranty claims against these manufacturers.

Special warning to purchaser -- Use of replacement filters and/or prefilters not manufactured by Minuteman or its designated licensees, will void all warranties expressed or implied.

A potential health hazard exists without original equipment replacement.

All warranted items become the sole property of Minuteman or its original manufacturer, whichever the case may be.

Minuteman disclaims any implied warranty, including the warranty of merchantability and the warranty of fitness for a particular purpose.

Minuteman assumes no responsibility for any special, incidental or consequential damages.

This limited warranty is applicable only in the U.S.A. and Canada, and is extended only to the original user/purchaser of this product. Customers outside the U.S.A. and Canada should contact their local distributor for export warranty policies. Minuteman is not responsible for costs or repairs performed by persons other than those specifically authorized by Minuteman. This warranty does not apply to damage from transportation, alterations by unauthorized persons, misuse or abuse of the equipment, use of non-compatible chemicals, or damage to property, or loss of income due to malfunctions of the product.

If a difficulty develops with this machine, you should contact the dealer from whom it was purchased.

This warranty gives you specific legal rights, and you may have other rights which vary from state to state. Some states do not allow the exclusion or limitation of special, incidental or consequential damages, or limitations on how long an implied warranty lasts, so the above exclusions and limitations may not apply to you.

Cord Electric Group	Three years parts, two years labor, ninety days travel (Not to exceed two hours)
Exceptions	Port-A-Scrub, one year parts, six months labor MPV 13, one year parts MPV 14 and 18, two years parts, one year labor Rapid Air blower, one year parts, one year labor Pneumatic Vacuums, three years parts, one year labor EX 12 and EX 12H, one year parts, one year labor
Battery Operated Group	Three years parts, two years labor, ninety days travel (Not to exceed two hours)
Exceptions	Sweepers, one year parts, one year labor, ninety days travel (Not to exceed two hours)
Replacement parts	Ninety days
Batteries	0-3 months replacement, 4-12 months pro-rate
Polypropylene Plastic Tanks	Ten years, no additional labor

Minuteman[®]

Excellence Meets Clean

988729UM REV * 02/09



Minuteman International Inc. • 14N845 U.S. Route 20 • Pingree Grove, IL 60140-8893 • U.S.A.
Phone: 630 627-6900 • Fax 630 627-1130