

# Pre-Sweep

Model: 340700

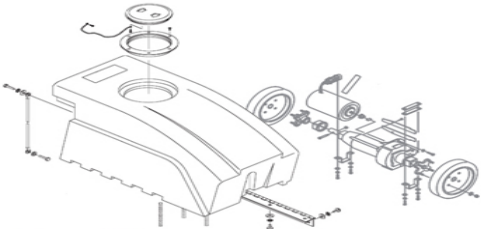

**FLOOR-EQUIPMENT-PARTS.COM**

## OPERATION

## SERVICE

## PARTS

## CARE

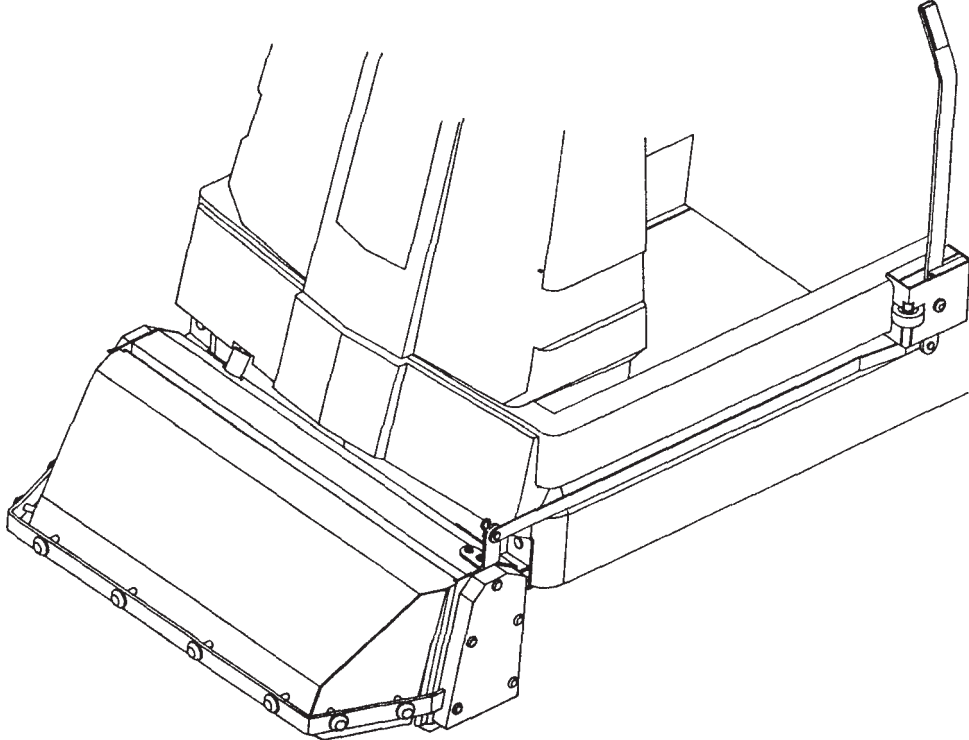

Revised 8/92

# TABLE OF CONTENTS

	Page
Operation Instructions.....	1
Installation Instructions .....	2, 3
Pre-Sweep Components .....	4
Replacement Part Numbers.....	5
Wiring Diagram .....	6

## IMPORTANT SAFETY INSTRUCTIONS

### CAUTION

Operators must read and understand this manual before operating or maintaining this equipment.

- Keep hands and feet clear of moving parts while machine is in operation.
- All switches must be in the "OFF" position when charging batteries.
- Electrical motors and components can cause an explosion when operated near explosive materials or vapors. Do not operate this machine near flammable materials such as solvent, thinners, fuels, grain dusts, etc.
- Make sure all switches are turned "OFF" and battery connections are removed before performing any maintenance procedures.
- Store or park this machine on a level surface only.
- Electrical Requirements - 24V DC

# OPERATING INSTRUCTIONS

## INSPECTION

Carefully unpack and inspect your machine for shipping damage. Each unit is tested and thoroughly inspected before shipment, and any damage is the responsibility of the delivering carrier who should be notified immediately. Read all instructions carefully before operating.

## WARNING

Electric shock could occur if used on wet surfaces. Do not expose to rain, store indoors.

Electrical motors can cause explosions when operated near explosive materials or vapors. Do not operate this machine near flammable materials such as solvents, thinners, fuels, grain dust, etc.

## ELECTRICAL

This machine is designed to operate on a standard 15 amp, 115 volt, 60 hz, AC circuit. Voltages below 105 volts AC or above 125 volts AC could cause serious damage to the motor.

## GROUNDING INSTRUCTIONS

To protect the operator from electrical shock, this machine must be grounded while in use. This machine is equipped with an approved three-conductor power cord and grounding type plug to fit the proper grounding type receptacle.

This machine is for use on a nominal 120 volt circuit and has a grounding plug that looks like the plug illustrated in sketch A. Make sure that the machine is connected to an outlet having the same configuration as the plug. No adapter should be used with this machine.

For equipment rated 150-250 volts: If the machine is provided with an attachment plug as shown in sketch B, it is intended for use on a 240 volt (nominal) circuit. No adapter is available for this plug.

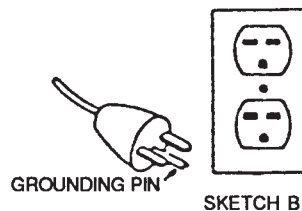
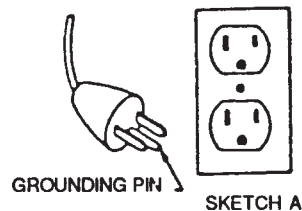

## EXTENSION CORDS

If an extension cord is used, the wire size must be at least one size larger than the power cord on the machine and must be limited to 25 feet in length. Extension cord must be three-wire grounded.

## MAINTENANCE AND USAGE

Keep the motor intake cooling air screen clean. If this screen (on top of the motor) becomes clogged, it restricts the flow of cooling air to the motor and will cause overheating.

No lubrication of the motor is required. Machine is equipped with sealed bearings.

For optimum performance, empty and clean filter bag regularly. A clogged and dirty bag restricts the flow of air and results in reduced vacuum.

Do not operate the machine without removing coiled electric cable from around the motor head so as not to restrict the flow of exhausted cooling air and to prevent overheating.

Always unplug the machine when removing the motor head off the tank. This will prevent the accidental starting of the motor and the possibility of fingers or objects getting into the unprotected impeller intake.

### POWER DISCONNECT

- 1) PARK MACHINE ON LEVEL SURFACE AND SET PARKING BRAKE
- 2) KEY SWITCH MUST BE IN THE "OFF" POSITION
- 3) DISCONNECT DC POWER BEFORE PERFORMING ANY MODIFICATIONS TO THE MACHINE
- 4) DISCONNECT BATTERY CHARGER AND STORE OUT OF WORK AREA

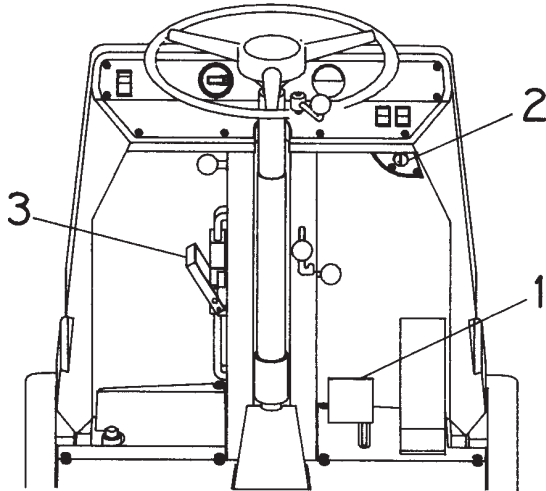

STEP 1

### WIRE HARNESS CONNECTIONS

- 1) REMOVE FRONT ELECTRICAL BOX COVER AND SET ASIDE
- 2) CUT OUT PRESWEEP SWITCH HOLE IN DASHBOARD WITH SHARP KNIFE
- 3) USE WIRE FISH AND PULL 4 WIRES WITH QUICK CONNECT TERMINALS THROUGH THE NEW SWITCH HOLE
- 4) CONNECT WIRES TO PRESWEEP SWITCH AS FOLLOWS
  - a) RED LEAD TO TOP RIGHT ON SWITCH
  - b) WHITE LEAD TO CENTER RIGHT ON SWITCH
  - c) BLACK / YELLOW LEAD TO TOP LEFT ON SWITCH
  - d) BLACK LEAD TO CENTER LEFT ON SWITCH
- 5) CONNECT RED POWER LEAD WITH 5/16 RING TONGUE TO TOP OF MAIN FUSE
- 6) CONNECT BLACK AND YELLOW LEAD WITH 5/16 RING TONGUE TO BOTTOM SIDE OF TOP CONTACTOR SWITCH
- 7) REPLACE FRONT COVER AND PUSH SWITCH INTO HOLE

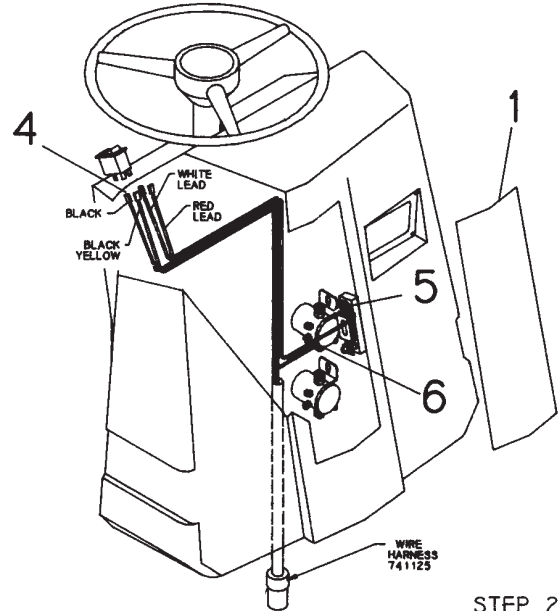

STEP 2

### PRESWEEP INSTALLATION

- 1) REMOVE LOWER FRONT COVER PANEL AND STORE AWAY
- 2) INSTALL LEFT AND RIGHT MACHINE BRACKETS USING FASTENERS PROVIDED.

710986	3/8-16 x 1" TRUSS HEAD BOLT
711507	3/8 FLAT WASHER
711380	3/8-16 NYLOCK NUT
340714	MACHINE BRACKET LEFT
340715	MACHINE BRACKET RIGHT

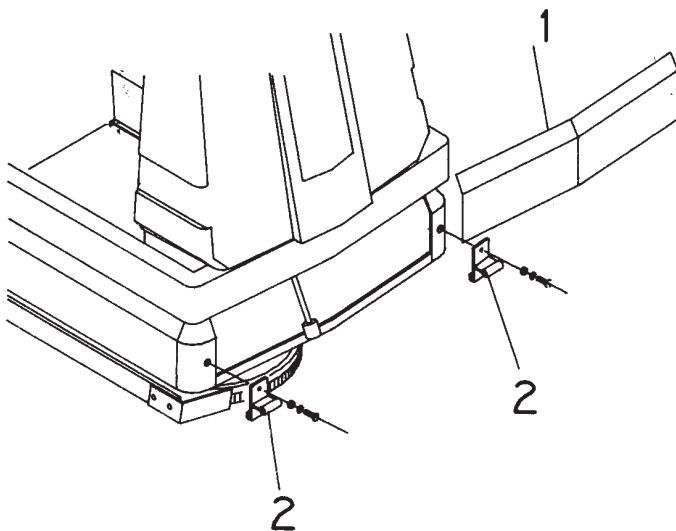

STEP 3

### PRESWEEP INSTALLATION

- 1) INSTALL VELCRO TAPE STRIPS ON TOP OF BLACK METAL-FRAME JUST UNDER FRONT COWLING, ONE EACH SIDE OF CENTER
- 2) PRESS TOP FLANGE OF REPLACEMENT COVER BETWEEN FRAME AND FRONT COWLING
- 3) SECURE BOTTOM OF REPLACEMENT COVER WITH EXISTING WING BOLTS IN PLACE ON FRAME

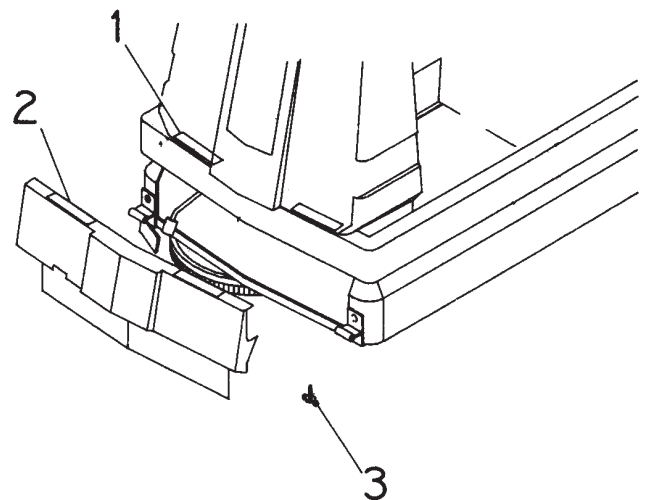

STEP 4

### PRESWEEP INSTALLATION

- 1) LOCATE AND DRILL 17/32 DIAMETER HOLE ON SIDE OF MACHINE AS SHOWN BELOW.
- 2) INSTALL LEVER AND CONTROL BOX WITH FASTENERS PROVIDED.
 

340748	LEVER CONTROL BOX
340753	LIFT LEVER
710993	1/2-13 x 2.25 SCREW
340744	SPRING
711509	1/2 FLAT WASHER
711376	1/2 NYLOCK NUT

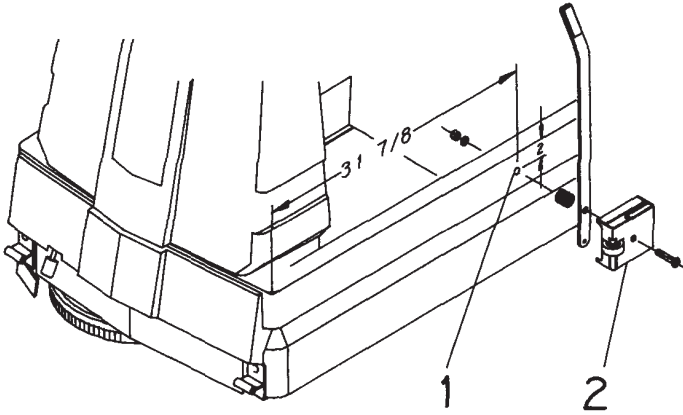

STEP 5

### PRESWEEP INSTALLATION

- 1) POSITION AND ALIGN PRESWEEP ASSEMBLY TO MACHINE BRACKETS ATTACHED TO LOWER FRONT CORNERS.
- 2) LOCK PRESWEEP ONTO BRACKETS USING HITCH PINS AND KEEPER CLIPS AS SHOWN BELOW.
 

340755	HITCH PIN ASSEMBLY
809799	KEEPER CLIP

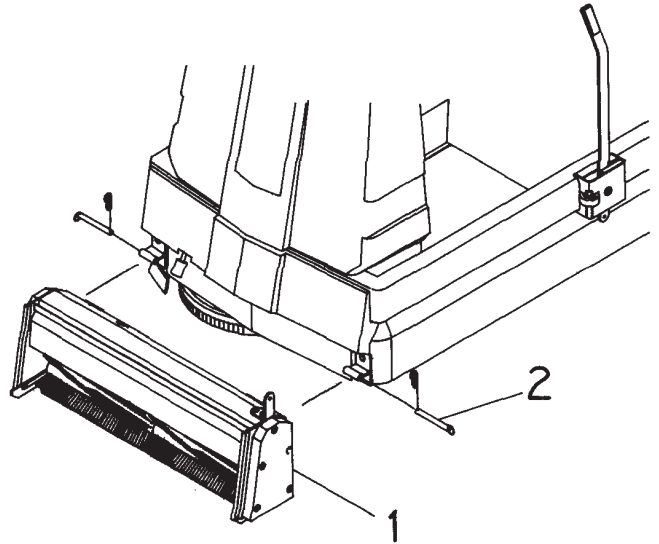

STEP 6

### PRESWEEP INSTALLATION

- 1) ATTACH LIFTING STRAP FROM PRESWEEP TO LEVER USING PIN, WASHER, AND KEEPER CLIP.
 

340752	LIFTING STRAP
450034	PIN
711506	5/16 FLAT WASHER
711808	KEEPER CLIP
- 2) CONNECT POWER PLUG TO PRESWEEP RECEPTACLE.

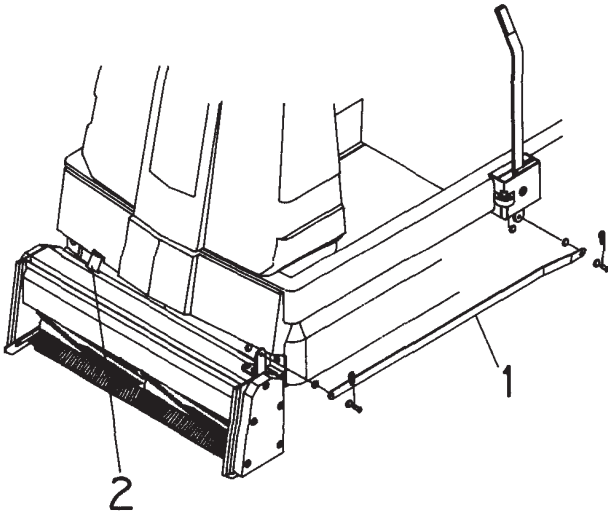

STEP 7

### PRESWEEP ADJUSTMENT

- 1) RELEASE CONTROL LEVER TO LOWER PRESWEEP TO CONTACT THE FLOOR
- 2) LEVEL PRESWEEP TO FLOOR BY ADJUSTING LEVELER BOLTS AT EACH END OF THE PRESWEEP MACHINE
- 3) WITH PRESWEEP ON— MOVE THE SCRUBBER FORWARD 3 TO 5 FEET TO ALLOW THE BRUSHES TO LAY OVER
- 4) TURN OFF PRESWEEP AND SCRUBBER. READJUST AS IN STEP 2

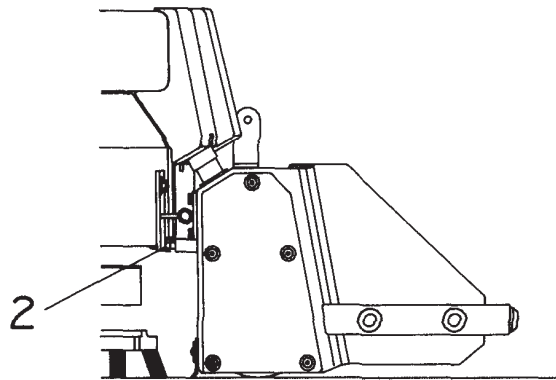

STEP 8

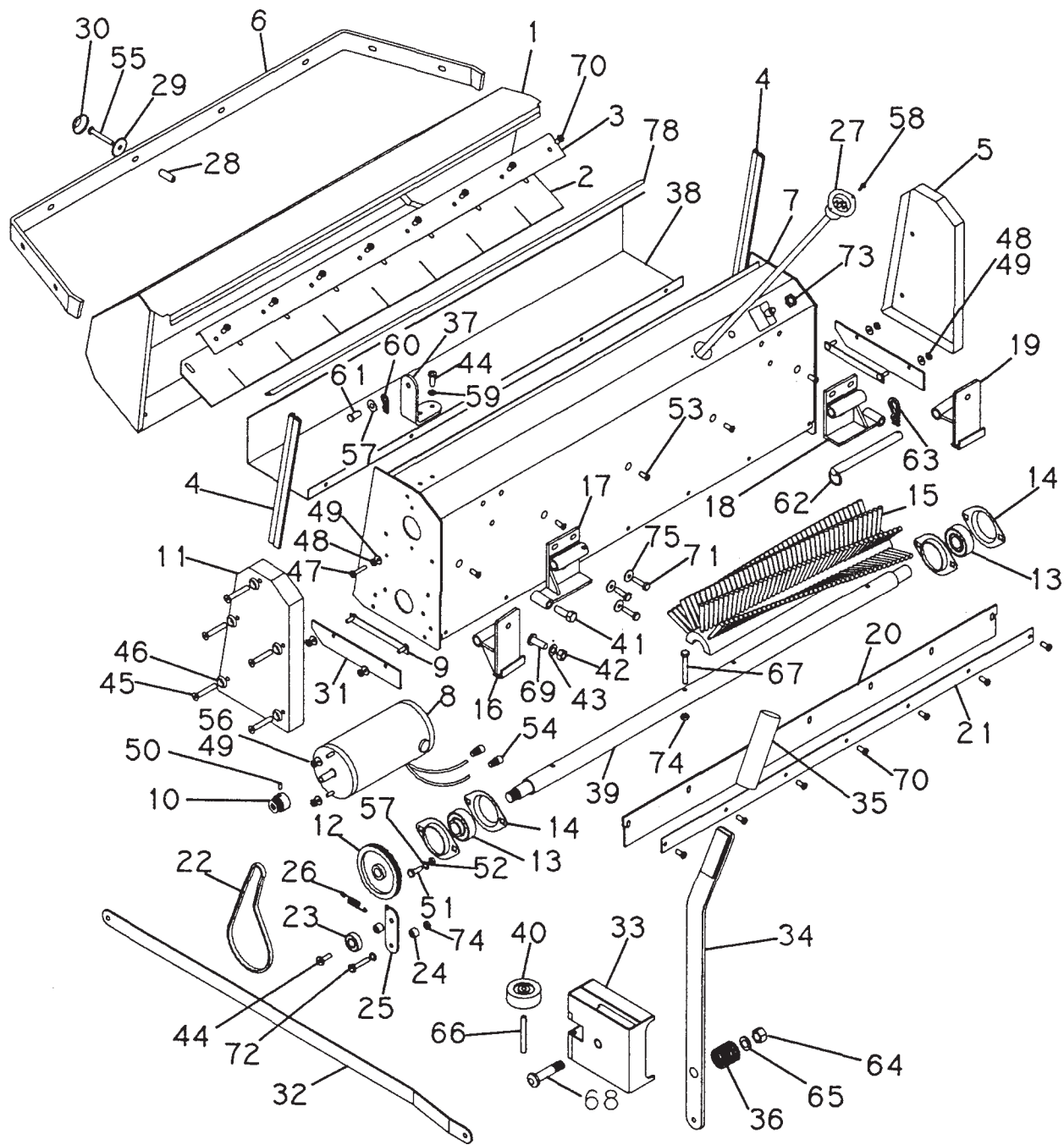

## Parts List

Item	Part No.	Qty.	Description	Item	Part No.	Qty.	Description
1	340731	1	Hopper Assembly	39	340740	1	Axle Brush
2	340735	1	Skirt Hopper	40	828214	1	Caster Wheel
3	340734	1	Plate Hopper Skirt	41	711242	2	BLT-HH 3/8-16 x 1.00
4	340732	2	Seal Hopper	42	711380	2	Nut-NLoc 3/8-16
5	340713	1	Cover End Idle Side	43	711507	2	WSR-Flat .37 x 1.12
6	340702	1	Bumper Front	44	710180	3	SCR-MC 1/4-20 x .75
7	340717	1	Frame Assembly	45	710600	10	SCR-MC 1/4-20 x 1.62
8	833339	1	Motor 24V DC	46	712319	10	WSR-Finish
9	340725	2	Plate Side Skirt	47	710357	1	SCR-MC 10-32 x .75
10	340754	1	Pulley Drive Motor	48	711350	5	Nut-Nyloc 10-32
11	340712	1	Cover End Drive Side	49	711503	7	WSR-Flat #10
12	340739	1	Pulley Brush	50	711003	1	SCR-SK 10-32 x .25
13	881059	2	Bearing	51	711228	4	BLT-HH 5/16-18 x .75
14	340742	4	Flange Bearing	52	711374	4	Nut-Nyloc 5/16-18
15	340701	2	Brush Pre-Sweep (2 sets required)	53	712818	5	SCR-MC 10-24 x .50
16	340715	1	Bracket, Right	54	740005	2	Cap, Wire
17	340723	1	Bracket, Right	55	710385	8	SCR-MC 1/4-20 x 1.50
18	340722	1	Bracket, Left	56	712638	2	Nut-Hex 10/24
19	340714	1	Bracket, Left	57	711506	10	WSR-Flat 5/16
20	340738	1	Skirt, Rear	58	710303	2	SCR-MC 6-32 x .50
21	340724	1	Plate Rear Skirt	59	711544	2	WSR-Helical 1/4
22	340746	1	Belt Drive	60	711808	2	Cotter Pin- Hair
23	828588	1	Bearing	61	450034	2	Clevis Pin
24	762371	2	Bushing	62	340755	2	Pin Assembly
25	340733	1	Arm Belt Tension	63	809799	2	Clip Hitch Pin
26	762084	1	Spring	64	711376	1	Nut-Nyloc 1/2-13
27	741127	1	Power Cord Pre-Sweep	65	711509	1	WSR-Flat 1/2
28	762399	8	Bushing	66	711660	1	Rollpin .25 x 2.50
29	762314	8	Washer	67	711220	4	BLT-HH 1/4-20 x 2.50
30	762313	8	Cap	68	710993	1	SCR-SC 1/2-13 x 2.25
31	340743	2	Skirt Side	69	710986	2	SCR-SC 3/8-16 x 1.00
32	340752	1	Strap Lift	70	712822	15	SCR-THMS 10-24 x .50
33	340748	1	Lever Weldment	71	711203	6	BLT-HH 1/4-20 x .62
34	340753	1	Lever Lift Weldment	72	711207	1	BLT-HH 1/4-20 x 1.00
35	762086	1	Grip, Handle	73	740106	1	Circuit Breaker
36	340744	1	Spring Lever	74	711373	5	Nut-Nyloc 1/4-20
37	340750	1	Bracket Lift	75	711505	7	WSR-Flat 1/4
38	340711	1	Tube, Front Half	78	340757	1	Seal Cover

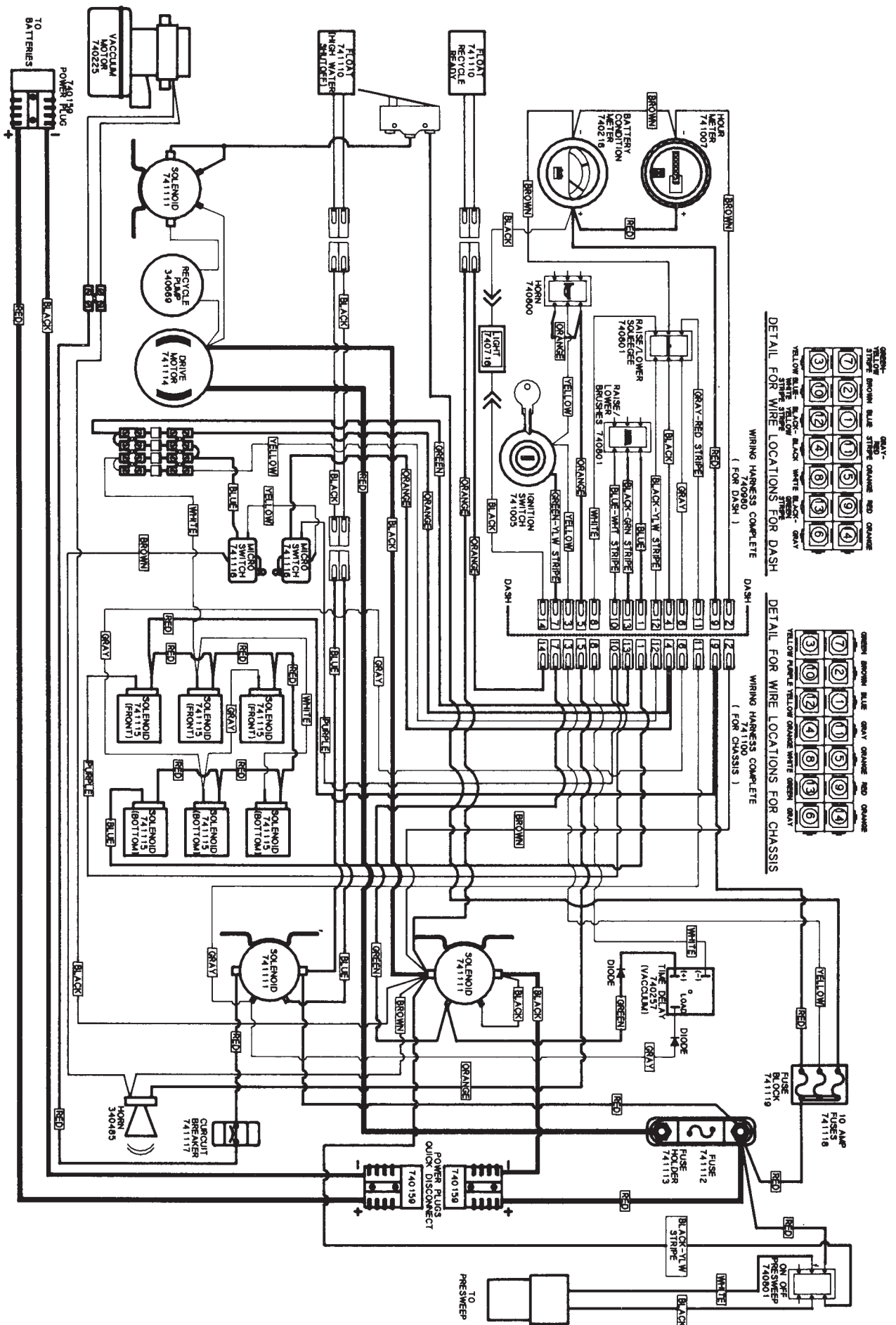



# LIMITED WARRANTY

Minuteman International, Inc. warrants to the original purchaser/user that this product is free from defects in workmanship and materials under normal use and service for a period of three years from date of purchase. In addition, Minuteman International, Inc. will, at its option, honor labor warranty claims for the first 12 months from date of sale, provided such claims are submitted through and approved by factory authorized repair stations. Minuteman International, Inc. will, at its option, repair or replace without charge, except for transportation costs, parts that fail under normal use and service when operated and maintained in accordance with the applicable operation and instruction manuals.

This warranty does not apply to normal wear, or to items whose life is dependent on their use and care, such as belts, cords, switches, hoses, rubber parts, electrical motor components or adjustments. Parts not manufactured by Minuteman International, Inc. such as engines, batteries, battery chargers, hydraulic pumps, and tires are covered by and subject to the warranties and/or guarantees of their manufacturers. Please contact Minuteman International, Inc. for procedures in warranty claims against these manufacturers.

**Special warning to purchaser** — Use of replacement filters and/or prefilters not manufactured by Minuteman International, Inc. or its designated licensees, will void all warranties expressed or implied.

A potential health hazard exists without exact original equipment replacement.

All warranted items become the sole property of Minuteman International, Inc. or its original manufacturer, whichever the case may be.

Minuteman International, Inc. disclaims any implied warranty, including the warranty of merchantability and the warranty of fitness for a particular purpose. Minuteman International, Inc. assumes no responsibility for any special, incidental or consequential damages.

This limited warranty is applicable only in the U.S.A. and Canada, and is extended only to the original user/purchaser of this product. Customers outside the U.S.A. and Canada should contact their local distributor for export warranty policies. Minuteman International, Inc. is not responsible for costs or repairs performed by persons other than those specifically authorized by Minuteman International, Inc. This warranty does not apply to damage from transportation, alterations by unauthorized persons, misuse or abuse of the equipment, use of non-compatible chemicals, or damage to property, or loss of income due to malfunctions of the product.

If a difficulty develops with this machine, you should contact the dealer from whom it was purchased.

This warranty gives you specific legal rights, and you may have other rights which vary from state to state. Some states do not allow the exclusion or limitation of special, incidental or consequential damages, or limitations on how long an implied warranty lasts, so the above exclusions and limitations may not apply to you.

## ***Minuteman***<sup>®</sup>

**World Headquarters**  
Minuteman International, Inc.  
111 South Rohlwing Road  
Addison, Illinois 60101

Minuteman Canada, Inc.  
2210 Drew Road  
Mississauga, Ontario  
L5S 1B1

(630) 627-6900  
FAX (630) 627-1130

(905) 673-3222  
FAX (905) 673-5161

987960  
Printed in U.S.A.