

Rugmaster 7 & 13 Gallon

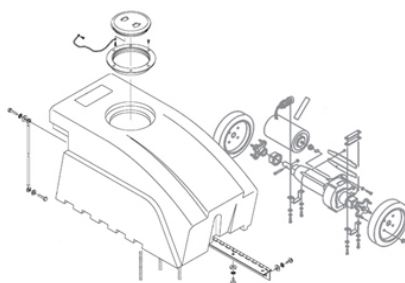

FLOOR-EQUIPMENT-PARTS.COM

Model:
MC828333
MC831210
MC829139
MC831470

OPERATION

SERVICE

PARTS

CARE

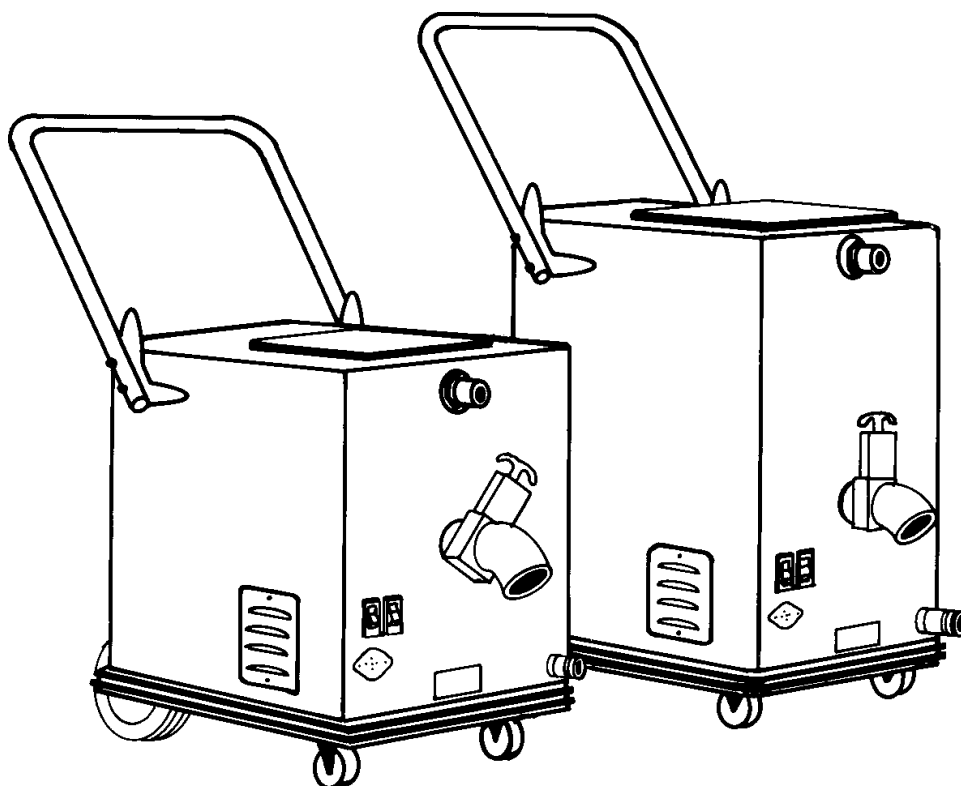

Revised 6/02

Minuteman[®]

FOR COMMERCIAL USE ONLY

IMPORTANT SAFETY INSTRUCTIONS

When using an electrical appliance, basic precautions should always be followed, including the following:

READ ALL INSTRUCTIONS BEFORE USING

WARNING - To reduce the risk of fire, electric shock, or injury:

- Do not leave appliance when plugged in. Unplug from outlet when not in use and before servicing.

WARNING

To reduce the risk of electrical shock. Do not expose to rain. Store indoors.

- Do not allow to be used as a toy. Close attention is necessary when used by or near children.
- Use only as described in this manual. Use only manufacturer's recommended attachments.
- Do not use with damaged cord or plug. If appliance is not working as it should, has been dropped, damaged, left outdoors, or dropped into water, return it to a service center.
- Do not pull or carry by cord, use cord as a handle, close a door on cord, or pull cord around sharp edges or corners. Do not run appliance over cord. Keep cord away from heated surfaces.
- Do not unplug by pulling on cord. To unplug, grasp the plug, not the cord.
- Do not handle plug or appliance with wet hands.
- Do not put any object into openings. Do not use with any opening blocked; keep free of dust, lint, hair, and anything that may reduce air flow.
- Keep hair, loose clothing, fingers, and all parts of body away from openings and moving parts.
- Do not pick up anything that is burning or smoking, such as cigarettes, matches, or hot ashes.
- Do not use without dustbag and/or filters in place.
- Turn off all controls before unplugging.
- Use extra care when cleaning on stairs.
- Do not use to pick up flammable or combustible liquids such as gasoline or use in areas where they may be present.
- Connect to a properly grounded outlet only. See grounding instructions.

SAVE THESE INSTRUCTIONS

INSPECTION

Carefully unpack and inspect your machine for shipping damage. Each unit is tested and thoroughly inspected before shipment, and any damage is the responsibility of the delivery carrier who should be notified immediately.

ELECTRICAL - 115 Volt

This machine is designed to operate on a standard 15 amp. 115 volt, 60 hz, AC circuit. Voltages below 105 volts AC or above 125 volts AC could cause serious damage to the motor.

ELECTRICAL - 240 Volt

This machine is designed to operate on a standard 10 amp. 230 volt, 50 hz, AC circuit.

WARNING

Electric motors can cause explosions when operated near explosive materials or vapors. Do not operate this machine near flammable materials such as solvents, thinners, fuels, grain dust, etc.

GROUNDING INSTRUCTIONS

This appliance must be grounded. If it should malfunction or breakdown, grounding provides a path of least resistance for electric current to reduce the risk of electric shock. This appliance is equipped with a cord having an equipment-grounding conductor and grounding plug. The plug must be plugged into an appropriate outlet that is properly installed and grounded in accordance with all local codes and ordinances.

DANGER

Improper connection of the equipment-grounding conductor can result in a risk of electric shock. Check with a qualified electrician or service person if you are in doubt as to whether the outlet is properly grounded. Do not modify the plug provided with the appliance — if it will not fit the outlet, have a proper outlet installed by a qualified electrician.

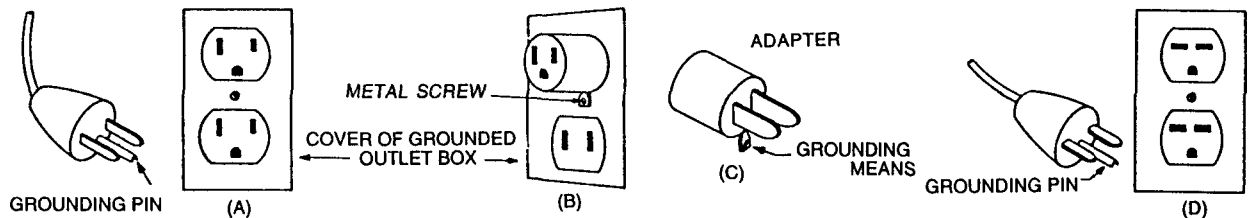

OPERATION

Mix the shampoo materials according to the directions on the label. (Extraction Shampoo is mixed 1 ounce per gallon of water.) Add approximately 1/2 gallon of water to the recovery tank with 2 to 3 ounces of Defoamer. (The Defoamer will react faster with the shampoo when diluted with a limited amount of water.) Fit the hose coupling to the wand and the supply tank. If the connection is not complete the shut-off valves inside each connection will not operate and no spray solution will pass through the tubes, as there is a check valve at each connection. As the light weight wand is pulled across the carpet, release the hot shampoo mist. The mist effectively dislodges dirt and residue buildup. The vacuum lifts out embedded dirt and nearly all the moisture for quick drying. Empty the unit using a bucket under the spigot. When empty, proceed with further cleaning. If necessary, clean inside the vacuum to remove all lint, soap, scum, etc. To empty the solution tank, put the hose into the tank.

Vac and Solution Hose Assembly 828924

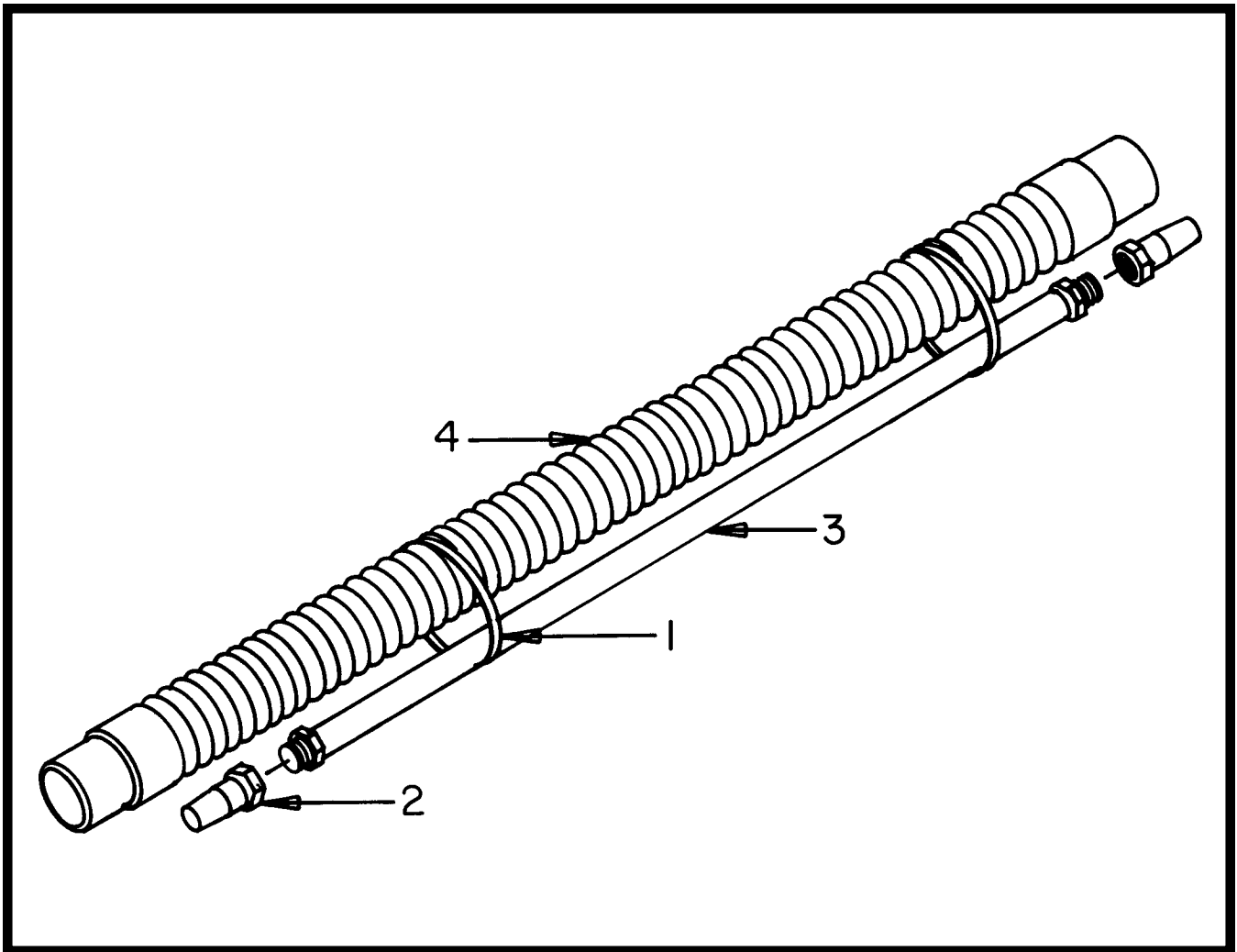

Parts List

Item	Part #	Qty	Description
1	828062	11	Ties
2	828368	2	Male Quick Coupler
3	828482	1	Solution Hose
4	829111	1	Vac Hose

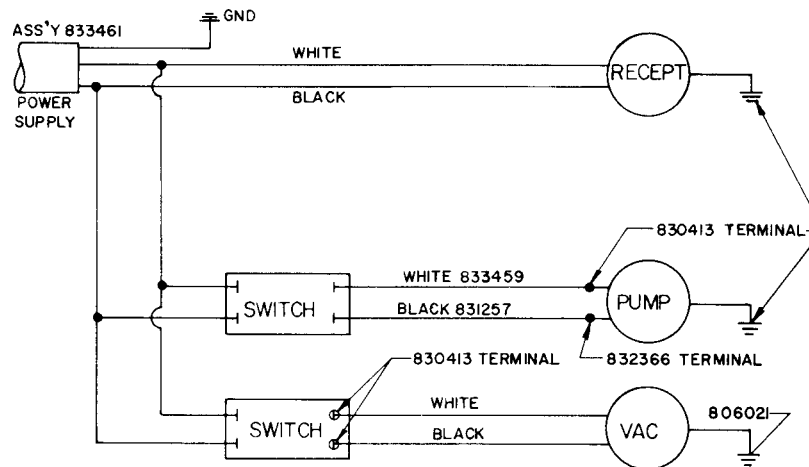

WIRING DIAGRAM 833151
SINGLE MOTOR

Care and Maintenance

1. Vac motor carbon brushes can be replaced with part number 80940. Worn or damaged carbon brushes can cause overheating and high amperage consumption. A periodic check of these brushes will prevent a more serious problem if worn brushed are continued in use.
2. The waste tank should be flushed with clean water after every use taking special care to keep the float age and gate valve area clear of lint and debris.
3. Protect the machine from freezing. Subjecting this unit to prolonged periods of sub-freezing temperatures can cause damage to the solution pump and other solution connections. If pump damage does occur, a parts breakdown of the pump can be found on the opposite page.
4. This machine is intended for wet pick-up only.
5. Storage of the vac and solution hose is not recommended in the waste recover tank. Damage to the standpipe and float can result in this practice.
6. Front casters and rear wheels should be lubricated with a light grease or a spray lubrication at least once a month, or more often depending upon the frequency of use. A spray lubrication should also be used on the brass connections periodically.
7. Always keep the solution tank screen strainer free of debris, which may get into the tank.
8. For best results and longer unit life, we recommend the use of Multi-Clean Extraction Shampoo, Defoamer, and other Multi-Clean carpet care products.

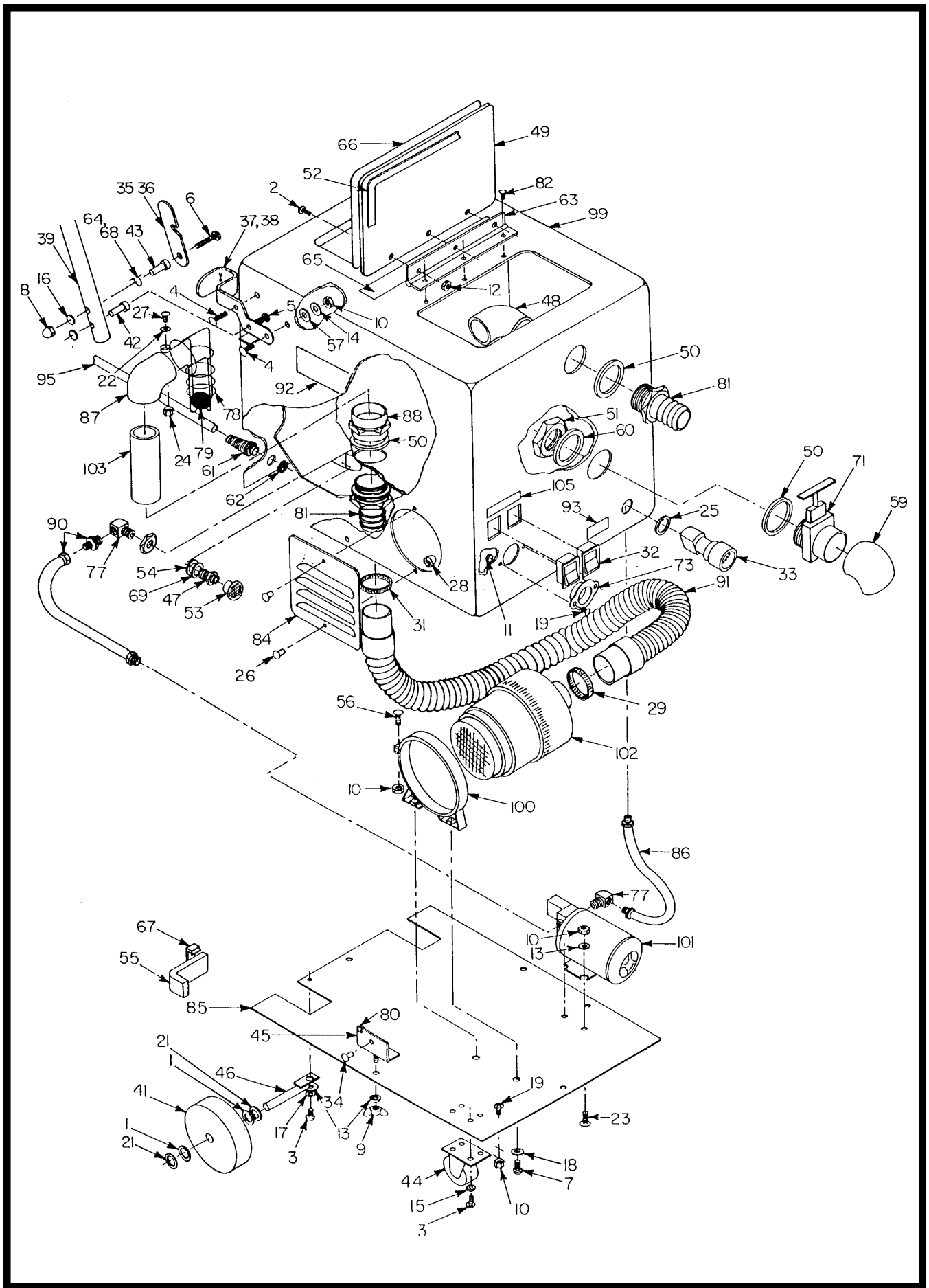

Parts List

Item	Part #	Qty	Description	Item	Part #	Qty	Description
1	711524	4	WSR-Wave .52 x .87 x .01	56	710184	1	SCR-MC 1/4-20 x 1.75 STPL
2	710203	3	SCR-MC 6-32 x .37 ST PL	57	828980	4	Gasket
3	710378	10	SCR-MC 1/4-20 x .50 ST PL	58	828981	1	Fitting Brass Nipple 1/4
4	710584	4	SCR-MC 1/4-20 x 1.00 ST PL	59	828998	1	45 Deg. Elbow
5	712567	2	SCR-MC 1/4-20 X 2.00 SS	60	829079	1	Gasket
6	710600	2	SCR-MC 1/4-20 X 1.62 STPL	61	150004	1	Strain Relief
7	711227	2	BLT-HH 5/16-18 X .62	62	711400	1	Nut-Pipe Lock 1/2
8	711352	4	Nut-Acorn 1/4-20 ST NI	63	829084	1	Hinge
9	711368	4	Nut-Wing 1/4-20 Nyloc PL	64	829110	1	Spring Left Handle
10	711425	8	Nut-Flanged Wizz 1/4-20	65	829119	1	Decal Solution Tank
11	711435	6	Nut-Flanged Wizz 6-32	66	829121	1	Decal Instruction
12	711438	3	Nut-Hex 6-32 BR Nipl	67	829130	2	Clip Bumper
13	711505	10	WSR-Flat 1/4	68	829131	1	Spring Right Handle
14	711516	4	WSR-Flat .31 x 1.25 x .05	69	829463	2	SS Washer
15			Use Item 17	70	450081	1	WSR-SS 1.908 x 2.41 x .03
16			Use Item 17	71	829651	1	Gate Valve
17	711544	14	WSR-Helical 1/4	72			
18	711575	2	WSR-Flat .31 x .75 x .06 STPL	73	829851	1	Flgd. Twst. Loc FM Midget
19	712077	6	SCR-SEMS TH 6-32 x .62 Zinc	*74	830064	1	Wire Lead Asm
20	711503	12	WSR-Flat #10	75	740014	3	Terminal QC Fem 1/4 Full Ins
21	712310	4	WSR-Flat .52 x .87 x .06 PL	*76	831257	1	Wire Lead Asm Black
22	712764	2	WSR SS #10	77	831306	1	Fitting Brass 90 1/4 MPT
23	710182	3	SCR 1/4-20 x 1.00 STPL	78	831338	1	Float Frame
24	712638	1	Nut-Hex 10-24 SS Nyloc	79	831344	1	Ball
25	712760	3	WSR-Flat .56 x 1.06 x .04 SS	*80	831657	3	Clip
26	712810	2	SCR-MC 10-24 x .37 STPL	81	831812	2	Fitting Abs 1.5MPT 1.5 Hose
27	712533	1	SCR-MC 10-24 x 1.25 SS	82			Use Item 18 & 11
28	712904	2	Nut-Acorn 10-24 BR Nipl	*83	740033	1	Terminal QC Male 1/4 Full Inc
29	760859	1	Clamp, Hose	84	833039	1	Louver
30	740010	1	Ring Terminal #10	85	833045	1	Base Plate Weldment
31	270249	1	Hose Clamp #24	86	833064	1	Hose Assy. .25 x 20"
32	809754	2	Switch Rocker	87	833159	1	Elbow 90 Deg. 1.5 x 1
33	828370	1	BH2-60 Female Coupler	88	833160	1	Adapter Abs 1.5FPT a 1.5 Slip
34	828893	8	Rivet Pop	*89	833459	1	Wire Lead Assembly White
35	828913	1	Latch Handle RH	90	833460	1	Hose Assy. .25 x 22.5"
36	828914	1	Latch Handle LH	91	833878	1	1.5 Hose Assy.
37	828917	1	Brace Handle RH	92	715385	2	Decal, "Minuteman" Lt Grey
38	828918	1	Brace Handle LH	93	715029	1	Decal, Serial Name Plate
39	828921	1	Handle	*94	740025	1	Term, FM 1/4 12-10 INS
*40	828924	1	Vac & Solution Hose Assy.	95	829881	1	Cord 14/3 x 30 FT.
41	828933	2	Wheel	*96	830294	1	Lead Black
42	828934	2	Spacer	97			
43	828935	2	Spacer	98	809444	2	Clip Cord
44	828936	2	Caster 2 1/2 PLT MT	99	833047	1	Tank SNV 13 Gal.
45	828942	4	Support Bracket	99A	833138	1	Tank SNV 7 Gal.
46	828943	2	Axle Weldment	100	833056	1	Vac Motor Mtg.
47	828945	1	Bulkhead Fitting 1/4 x 3/4	101	833067	1	Pump 100 PSI 115V
48	828959	1	Plastic Elbow 1-1/2	101A	833068	1	Pump 100 PSI 240V
49	828961	1	Cover	102	833147	1	Vac Mtr 120V
50	828970	3	WSR Neoprene 1.81 x 2.4 x .125	102A	833148	1	Vac Mtr 240V
51	828971	1	Nut 1-1/2 Pipe Thread	103	833164	1	Pipe 1.5 x 12 (13 gal)
52	828972	1	Gasket	103A	833137	1	Pipe 1.5 x 6 (7 gal)
53	828974	1	Strainer	104	833463	1	Lead White
54	828975	2	WSR Neoprene .75 x 1.5 x .09	105	833607	1	Decal
55	808077	1	Bumper 10"	*106	833826	1	Lint Bag
55A	828978	1	Bumper 60 1/2"				

*Not Shown

100 PSI PUMP 833068

TROUBLE SHOOTING

Pulsating Flow — Pump Cycling On and Off

- Restricted pump delivery. Check discharge lines, fittings, valves and spray nozzles for clogging or undersizing.

Failure to Prime — Motor Operates, But No Pump Discharge

- Restricted intake or discharge line. Open all line valves check for "jammed" check valve poppets and clean clogged lines.
- Air leak in intake line.
- Punctured pump diaphragm.
- Defective pump check valve.
- Crack in pump housing
- Worn pump bearing.

Motor Fails to Turn On

- Pump or equipment not plugged in electrically.
- Loose wiring connection.
- Pressure switch failure.
- Defective motor or rectifier.

Pump Fails to Turn Off — after Discharge Valves are Closed.

- Depletion of available liquid supply.
- Punctured pump diaphragm.
- Discharge line leak.
- Defective pressure switch.
- Insufficient voltage to pump.
- Defective pump check valve.
- Worn pump bearing.

Low Flow and Pressure

- Air leak at pump intake.
- Accumulation of debris inside pump and plumbing.
- Worn pump bearing (excessive noise).
- Punctured pump diaphragm.
- Defective rectifier or motor.
- Defective pump check valve.

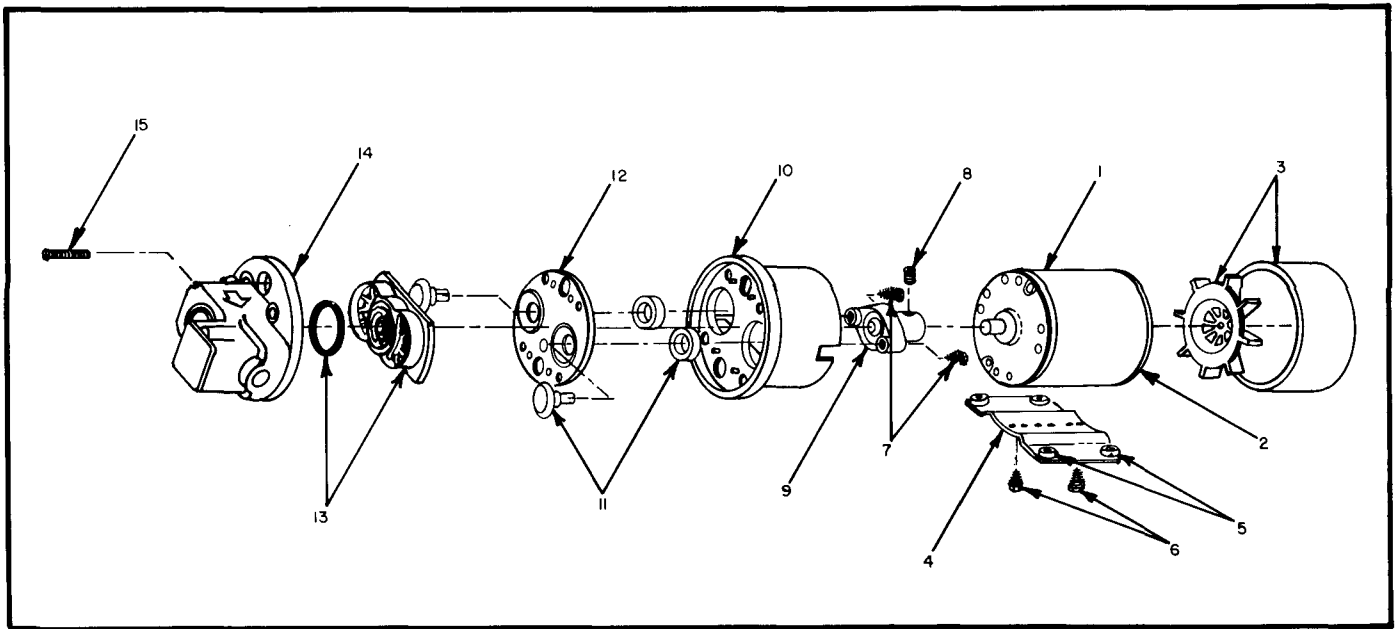

SERVICE TIPS

Refer to exploded view for Key Number. To disassemble, remove six pump head screws (15), rotate bearing cover (10) so drain notch is aligned with cam/bearing assembly set screw (8). Loosen set screw (use 1/8" size Allen Wrench) and slide pump head off shaft. Pistons (11) should always be replaced when new diaphragm is installed. Replace worn parts and reassemble. Be sure raised side of diaphragm faces the motor and radiused corner of pistons face diaphragm (coat motor shaft with grease prior to assembly). Hex stem of piston (11) must be aligned (free to enter) into hex hole in cam bearing assembly (9), otherwise diaphragm will leak. Tighten screw (7) partially, center pistons in diaphragm, then tighten screws securely.

Reassemble bearing cover and cam/bearing assembly to motor and retighten the set screw securely. Set screw MUST be positioned in shaft indentation. Positioning of this screw is critical to avoid mis-alignment and subsequent diaphragm damage.

Reassemble remaining pump head parts, using care to properly seat "O" ring (13) in check valve assembly and tighten pump head screws evenly.

PARTS LIST

Item No.	Part No.	Qty.	Description
1	Not Available		
2	833654	1	Brush Endbell/Rect. Assy.
3	Not Available		
4	Not Available		
5	Not available		
6	Not available		
*7	833653	2	Cam/Bearing Screws
*8	833652	1	Cam/Bearing Set Screw
*9	833656	1	Cam/Bearing Kit
10	Not available		
*11	833657	2	Pistons
*12	833658	1	Diaphragm Kit
*13	833659	1	Check Valve
14	833661	1	Upper Housing/Switch Assy.
15	Not available		
	833660		Pump Service Kit Includes * items

TOOLS AND ACCESSORIES

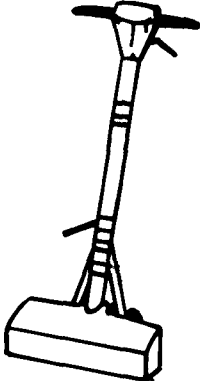
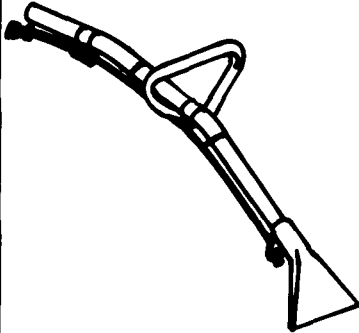
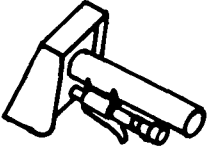
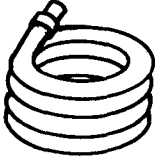
	<p>829601 160 Powerhead</p>
	<p>831255 Drag Wand Asy.</p>
	<p>828502 Hand Extraction Tool</p>
	<p>830750 Vac & Solution Hose 25 Ft.</p>

LIMITED WARRANTY

Minuteman International, Inc. warrants to the original purchaser/user that this product is free from defects in workmanship and materials under normal use and service for a period of three years from date of purchase. In addition, Minuteman International, Inc. will, at its option, honor labor warranty claims for the first 12 months from date of sale, provided such claims are submitted through and approved by factory authorized repair stations. Minuteman International, Inc. will, at its option, repair or replace without charge, except for transportation costs, parts that fail under normal use and service when operated and maintained in accordance with the applicable operation and instruction manuals.

This warranty does not apply to normal wear, or to items whose life is dependent on their use and care, such as belts, cords, switches, hoses, rubber parts, electrical motor components or adjustments. Parts not manufactured by Minuteman International, Inc. such as engines, batteries, battery chargers, hydraulic pumps, and tires are covered by and subject to the warranties and/or guarantees of their manufacturers. Please contact Minuteman International, Inc. for procedures in warranty claims against these manufacturers.

Special warning to purchaser — Use of replacement filters and/or prefilters not manufactured by Minuteman International, Inc. or its designated licensees, will void all warranties expressed or implied.

A potential health hazard exists without exact original equipment replacement.

All warranted items become the sole property of Minuteman International, Inc. or its original manufacturer, whichever the case may be.

Minuteman International, Inc. disclaims any implied warranty, including the warranty of merchantability and the warranty of fitness for a particular purpose. Minuteman International, Inc. assumes no responsibility for any special, incidental or consequential damages.

This limited warranty is applicable only in the U.S.A. and Canada, and is extended only to the original user/purchaser of this product. Customers outside the U.S.A. and Canada should contact their local distributor for export warranty policies. Minuteman International, Inc. is not responsible for costs or repairs performed by persons other than those specifically authorized by Minuteman International, Inc. This warranty does not apply to damage from transportation, alterations by unauthorized persons, misuse or abuse of the equipment, use of non-compatible chemicals, or damage to property, or loss of income due to malfunctions of the product.

If a difficulty develops with this machine, you should contact the dealer from whom it was purchased.

This warranty gives you specific legal rights, and you may have other rights which vary from state to state. Some states do not allow the exclusion or limitation of special, incidental or consequential damages, or limitations on how long an implied warranty lasts, so the above exclusions and limitations may not apply to you.

Minuteman[®]

World Headquarters
Minuteman International, Inc.
111 South Rohlwing Road
Addison, Illinois 60101

Minuteman Canada, Inc.
2210 Drew Road
Mississauga, Ontario
L5S 1B1

(630) 627-6900
FAX (630) 627-1130

(905) 673-3222
FAX (905) 673-5161

985721
Printed in U.S.A.