

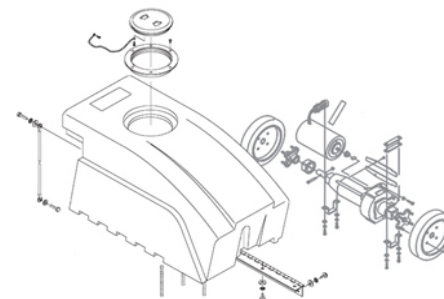

Owner's Manual

Operating and Servicing Instructions

www.hoover.com



FLOOR-EQUIPMENT-PARTS.COM

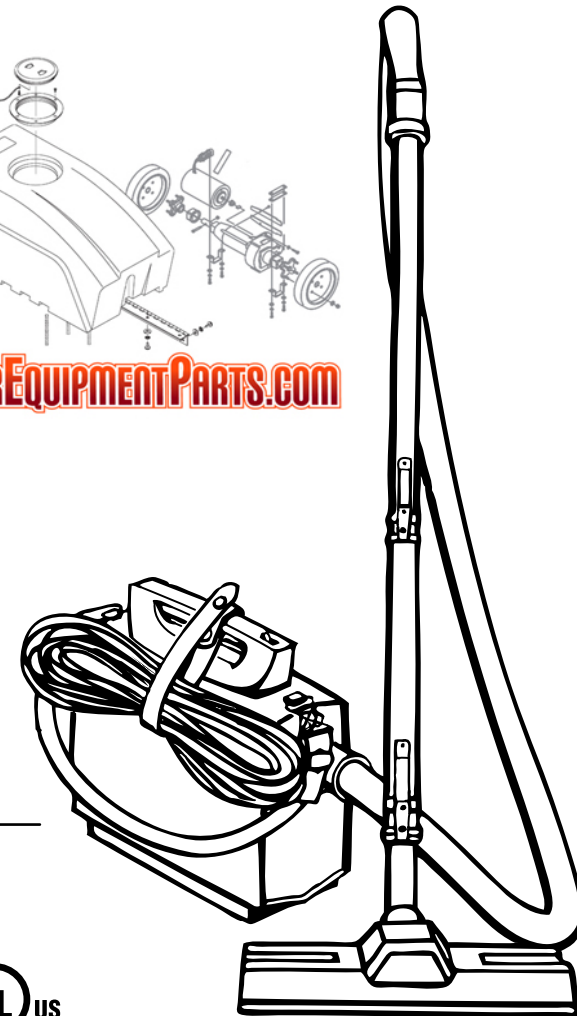

French



Please review this manual before operating your Hoover® appliance.

This cleaner meets Occupational Safety and Health Act (OSHA-29 CFR 1910 Subpart S) requirements.

©2008 All rights reserved. #59156663 R0. 8/08

Thank you for choosing a HOOVER® product.

Please enter the complete model and serial numbers in the spaces provided.

Model _____

MFG Code _____

Hint: Attach your sales receipt to this owner's manual. Verification of date of purchase may be required for warranty service of your HOOVER product.

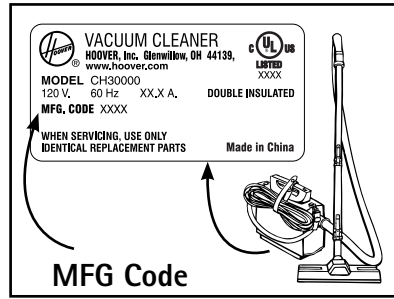

Cleaner Description

1. Combination Rug and Floor Nozzle
2. Carrying Strap (adjustable)
3. Cord
4. Carrying Handle
5. Cord Storage Strap snaps together on handle to store cord.
6. On-Off Switch
7. Bag Door Lock
8. Crevice Tool
9. Furniture Nozzle
10. Dusting Brush
11. Wall/Floor Brush
12. Plastic Latch Ring: rotate ring to attach tool or wand.
13. Extension Wands: Used with rug and floor nozzle. If added length is desired when using other tools, one or both wands may be used.
14. Spring Latch: Locks extension wands to nozzle and cleaning tools.

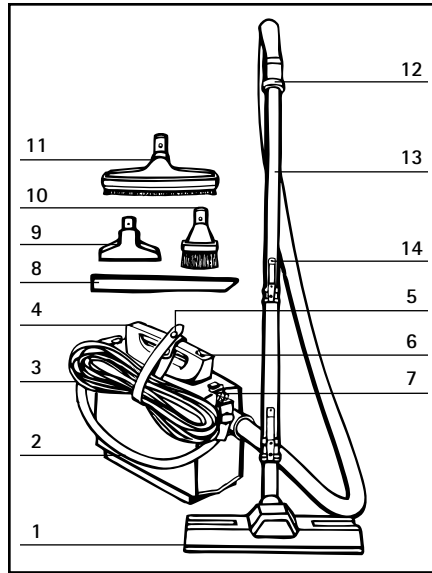

This vacuum is intended for commercial use.

Thermal Protector:

An internal thermal protector has been used in your cleaner to prevent overheating if a large item or clog gets caught in the nozzle or at the opening of the bag.

When the blockage is not removed, the thermal protector will trip and the cleaner will stop running.

If this happens, turn the cleaner OFF and disconnect the cleaner from the electrical outlet. Then, disconnect the nozzle and remove the obstruction. Within 30 minutes, the thermal protector will cool and automatically reset and cleaning may resume.

If the cleaner does not operate, allow additional time for the thermal protector to reset.

Note: The canister must remain unplugged during the 30 minute cooling period.

If you need assistance:

Visit our website at hoover.com. Click on the "Customer Service" link to find the service outlet nearest you OR Call 1-800-944-9200 for an automated referral of authorized service outlet locations (U.S. only) OR Call 1-800-263-6376 to speak with a representative in our Consumer Response Center; Mon-Fri 8am-7pm EST.

Please do not return this product to the store.

French

IMPORTANT SAFETY INSTRUCTIONS

When using an electrical appliance, basic precautions should always be followed, including the following:

READ ALL INSTRUCTIONS BEFORE USING THIS APPLIANCE

WARNING: To reduce the risk of fire, electric shock, or injury:

- Do not use outdoors or on wet surfaces.
- This appliance is provided with double insulation. Use only identical replacement parts. See instructions for Servicing of Double-Insulated Appliances.
- Close supervision is necessary when any appliance is used by or near children. Do not allow vacuum cleaner to be used as a toy or to run unattended at any time.
- Keep hair, loose clothing, fingers, feet and all parts of body away from openings, rotating agitator and other moving parts.
- Do not operate cleaner in bare feet or when wearing open toe shoes or sandals.
- Do not pick up anything that is burning or smoking, such as cigarettes, matches, or hot ashes.
- Do not use to pick up flammable or combustible liquids such as gasoline, or fine wood sandings, or use in areas where they may be present.
- Avoid picking up hard, sharp objects with the cleaner. They may damage the cleaner and the bag.
- Do not use without dust bag in place. Change bag frequently when picking up very fine materials such as powder.
- Use extra care when cleaning on stairs.
- Do not put any object into openings. Do not use with any opening blocked; keep free of dust, lint, hair, or anything that may reduce air flow.
- Do not pull or carry by cord, use cord as a handle, close door on cord or pull cord around sharp edges or corners. Do not run appliance over cord. Keep cord away from heated surfaces.
- Always disconnect cord from electrical outlet before servicing the cleaner.
- Do not leave cleaner when plugged in. Unplug from outlet when not in use and before servicing.
- Turn off all controls before unplugging.
- Do not unplug by pulling on cord. To unplug, grasp the plug, not the cord.
- Never handle plug or appliance with wet hands.
- The use of an extension cord is not recommended. If an extension cord is absolutely necessary, use at least a 16 gauge cord and as short as possible.
- Do not use with damaged cord or plug. If appliance is not working as it should, has been dropped, damaged, left outdoors, or dropped into water, take it to a Hoover Factory Service Center or Authorized Hoover Commercial Warranty Service Distributor.
- Use vacuum cleaner only for its intended use as described in this owner's manual. Use only attachments recommended by Hoover, Inc.; others may cause hazards.

SAVE THESE INSTRUCTIONS!

Polarization Instructions: To reduce the risk of electric shock, this appliance has a polarized plug (one blade is wider than the other). This plug will fit in a polarized outlet only one way. If the plug does not fit fully in the outlet, reverse the plug. If it still does not fit, contact a qualified electrician to install the proper outlet. Do not change the plug in any way.

WARNING – This product contains chemicals known to the State of California to cause cancer.

WASH HANDS AFTER HANDLING.

1. HOW TO USE

Rug and Floor Nozzle

The combination rug and floor nozzle has been designed to do an efficient job on both carpet and hard surface floors.

Hard Surface Floors

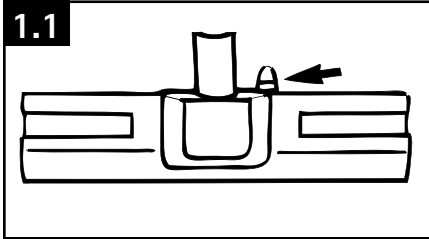

Lower brushes to clean bare floors by sliding indicator to BARE FLOOR.

Rugs

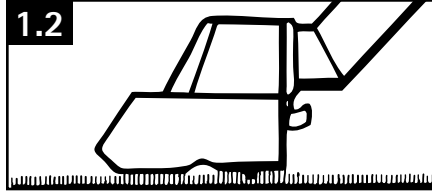

Raise brushes to clean rugs or carpet by sliding indicator to RUG.

For most efficient cleaning, place the nozzle flat on rugs and hard surface floors.

Edge Cleaning

This feature provides for improved cleaning of carpet edges near baseboards and solid furniture. Passages have been added to the side of the nozzle to increase air flow carrying dust down from the carpet edge to the nozzle.

Clean Stairs

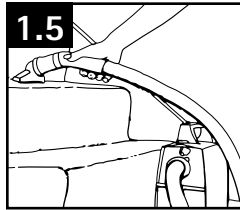

Place cleaner on stair.

Clean stairs from bottom to top.

Attach Tools

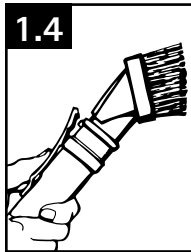
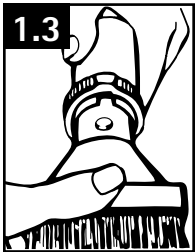

Attach tools to end of hose by rotating plastic latch ring until slots align; insert tool and rotate latch ring to lock.

To remove tool, reverse above procedure.

Attach tool to either extension wand by pushing button projection end of tool into spring latch of wand. Latch will snap into place when locked together.

To disconnect, press down on the center of the spring latch and remove tool.

Blower

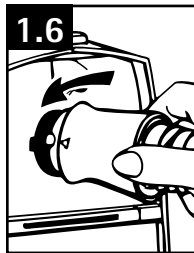

Used to blow dirt out of areas where it is impossible for suction to reach.

To use blower, turn hose connector as shown and remove hose from bag door.

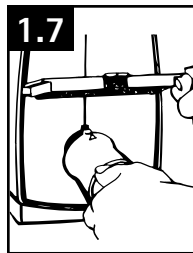

Pull up louvered door at back of cleaner and insert hose connector into corresponding slots in opening.

Turn hose connector in either direction until it locks into place.

French

2. MAINTENANCE

Disconnect cleaner from electrical outlet before attempting to service it in any manner.

The Bag

Check bag from time to time and empty when necessary. When the bag is filled with dirt, the cleaner will not operate efficiently. Never operate cleaner without the bag.

CAUTION: Very fine materials, such as face powder or cornstarch will seal the pores of the bag. When the cleaner is used to remove material of this nature, the bag should be emptied frequently.

Empty Bag

Disconnect cleaner from electrical outlet.

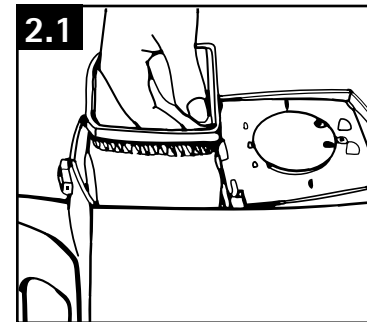

Bag is located behind bag door at front of cleaner.

Remove hose and set cleaner on end.

Turn bag door lock clockwise and open door.

Remove bag by grasping tab on inside of bag ring and pulling bag from cleaner.

Hold bag ring firmly on a paper while shaking bag vigorously until it is clean. The bag may also be turned inside out for a thorough cleaning.

Replace bag. Use crevice tool or similar object to push bag into proper position. Bag ring should be seated firmly against ridges in cleaner.

Secondary Filter

Disconnect cleaner from electrical outlet.

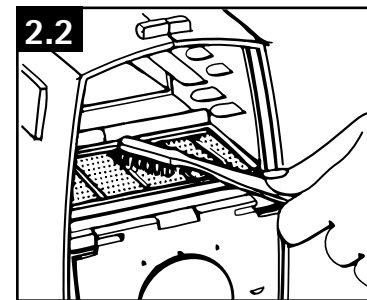

The secondary filter protects the motor from dirt particles.

It is located at the front of the bag compartment.

When bag is removed, check filter, which is not removable.

If filter is dirty, remove dirt with a small brush.

Rug and Floor Nozzle

To maintain cleaning effectiveness of your rug and floor nozzle, brushes may need to be replaced occasionally. See your nearest Hoover Factory Service Center or Authorized Warranty Dealer for new brushes.

Lubrication

The motor is equipped with bearings that contain sufficient lubrication for the life of the motor. The addition of lubricant could cause damage. Therefore, do not add lubricant to motor bearings.

Service

To obtain approved HOOVER service and genuine HOOVER parts, locate the nearest Hoover Sales and Service Center or Authorized Hoover Warranty Service Dealer (Depot) by:

- checking the Yellow Pages under “Vacuum Cleaners - Household”
- checking the Service section of Hoover on-line at hoover.com
- calling 1-800-944-9200 for an automated referral of authorized service outlet locations (U.S. only).

Do not send your cleaner to Hoover in Glenwillow, Ohio for service, this will only result in delay.

If further assistance is needed, contact the Hoover Consumer Response Center, 1-800-263-6376, Mon-Fri 8AM-7PM EST.

In Canada: Carson Building; 100 Carson St.; Etobicoke, ON; M8W3R9; 1-800-263-6376, Mon-Fri 8AM-7PM EST.

Always identify your cleaner by the complete model number when requesting information or ordering parts. (The model number appears on the back of the cleaner.)

Servicing Double-Insulated Appliances

This vacuum cleaner is double-insulated. In a double-insulated appliance, two systems of insulation are provided instead of grounding. No grounding means is provided on a double-insulated appliance, nor should any means for grounding be added. Servicing a double-insulated appliance requires extreme care and knowledge of the system, and should be done only by qualified service personnel. Replacement parts must be identical to those parts being replaced. A double-insulated appliance is marked with the words “DOUBLE-INSULATION” or “DOUBLE-INSULATED”. The symbol  may also be marked on the appliance.

3. TROUBLESHOOTING

If a minor problem develops, it usually can be remedied quite easily when the cause is identified by using the check list below.

PROBLEM	POSSIBLE REASON	POSSIBLE SOLUTION
Cleaner won't run	1. Power cord not firmly plugged in.	1. Plug unit in firmly.
	2. No voltage in wall plug.	2. Check fuse or breaker.
	3. Blown fuse or tripped breaker.	3. Replace fuse/reset breaker.
	4. Thermal Protector Activated	4. Allow cleaner to cool per instructions on pg. 2.
Cleaner suction low	1. Bag full.	1. Empty bag.
	2. Obstruction in nozzle.	2. Remove obstruction.
	3. Secondary filter dirty.	3. Clean filter.
Nozzle won't pick up	1. Nozzle brush worn.	1. Replace brush.

French