

FLOOR-EQUIPMENT-PARTS.COM

3110/3120

Commercial Upright Vacuum Cleaner
Aspirateur Commercial
Aspirador Comercial

Part No.:

Single Motor Upright Vacuum Cleaner

614215 - 3110 12" 120V/60Hz

614216 - 3110 15" 120V/60Hz

Dual Motor Upright Vacuum Cleaner

614306 - 3120 12" 120V/60Hz

614217 - 3120 15" 120V/60Hz

614218 - 3120 18" 120V/60Hz

**Operator Manual
and Parts List**

**Opérateur Manuel
et Liste Des Pièces**

**Manual De Operador
Y Lista De Repuestos**



614264
Rev. 02 (01-05)

PARTS LIST - LISTE DES PIÈCES - LISTA DE PIEZAS

BLACK PARTS:

1 1025310 COVER ASM., BLK HSG W/LBLS

48 1025308 HOUSING, BAG, BLACK

BAG HOUSING GROUP

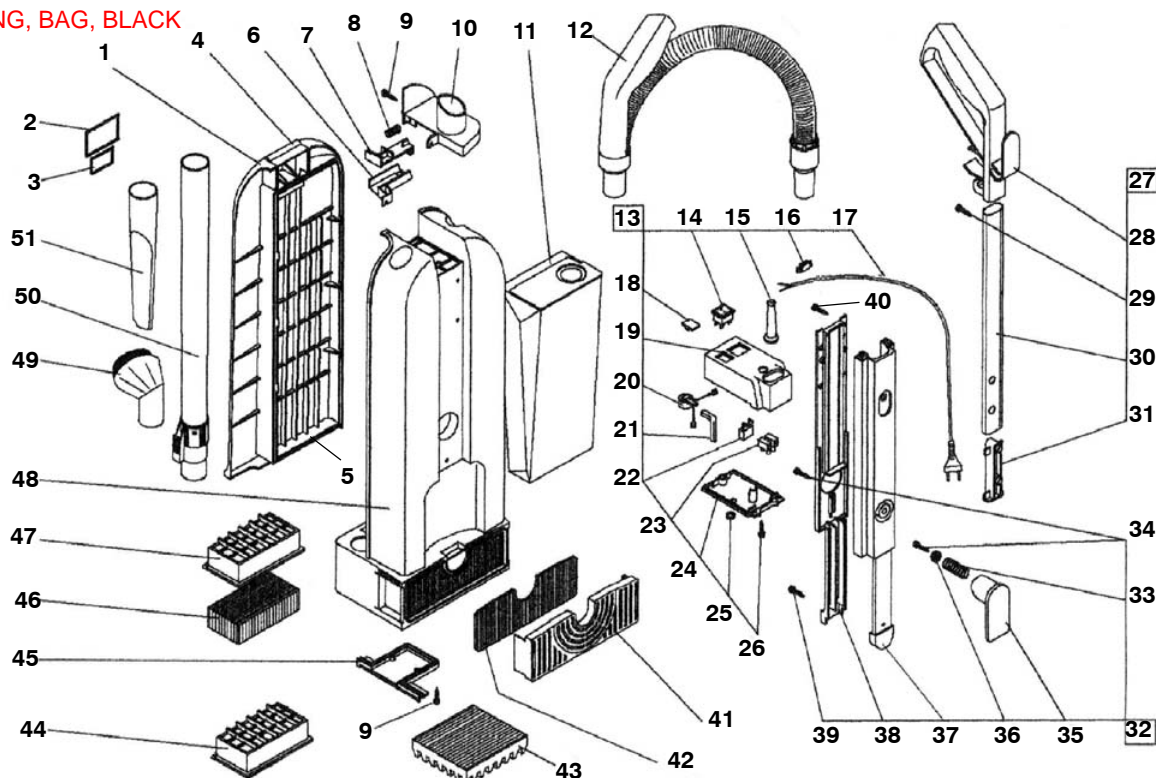

REF	PART #	DESCRIPTION	QTY.
∇ 1	1015713	COVER ASM., TEN HSG W/LBLS	1
▲ 2	613280	LABEL, WARNING	1
▲ 3	1015715	LABEL, FILTER IMPORTANT	1
▲ 4	1022847	LATCH, CVR, BAG HSNQ, W/SPRNG	1
▲ 5	1015716	●GASKET, COVER, BAG HOUSING	1
6	1015620	GUIDE, BUTTON	1
7	1015621	BUTTON, HOLDER, BAG	1
8	1015619	SPRING, BUTTON, BAG HOLDER	1
9	1015719	SCREW KIT, 3.9X16, KIT=20 PCS	1
10	1015618	ADAPTOR, BAG	1
11	1014505	●BAG, FLTR PCK= 8 BAGS/ 2 FLTR	1
12	1015651	●HOSE EXT., W/HANDLE GRIP	1
∇ 13	1015600	HOUSING ASM., SWITCH	1
▲ 14	1015617	●SWITCH, MAIN, 15A	1
▲ 15	1015607	STRAINRELIEF	1
▲ 16	1015646	CLAMP, CORD	1
▲ 17	1015647	●CORD, POWER 17/3X15M, YEL	1
▲ 18	1015616	LENS, RED, BAG FULL	1
▲ 19	1015603	HOUSING, SWITCH	1
▲ 20	1015615	●SENSOR, VACUUM, W/LIGHT	1
▲ 21	1015606	TUBE, SENSOR	1
▲ 22	1015672	FILTER, ELECTRICAL, RFI	1
▲ 23	130005	TERMINAL, BLOCK, 3 POLE	1
▲ 24	1015708	COVER, HOUSING, SWITCH	1
▲ 25	1015707	SEAL, ORG	1
▲ 26	1015727	SCREW KIT, 3.9X32, KIT=20 PCS	1

REF	PART #	DESCRIPTION	QTY.
∇ 27	1015711	HANDLE ASM.	1
▲ 28	1015648	HANDLE	1
▲ 29	1015726	SCREW KIT, 3.9X13, KIT=20 PCS	1
▲ 30	1015649	TUBE, HANDLE, W/BUTTONS	1
▲ 31	1015650	BUTTON ASM., HANDLE	1
∇ 32	1015710	PANEL ASM., FRONT, ELECTRICAL	1
▲ 33	1015596	SPRING	1
▲ 34	1015718	SCREW KIT, 3.5X16, KIT=20 PCS	1
▲ 35	1015605	HOOK CORD, LOWER	1
▲ 36	1015604	CLIP, SPRING, RING	1
▲ 37	1015613	HANDLE ASM., FRAME	1
▲ 38	1015614	COVER, HANDLE	1
▲ 39	1015724	SCREW KIT, 3.9X9.5, KIT=20 PCS	1
▲ 40	1015721	SCREW KIT, 3.5X16, KIT=20 PCS	1
41	1015608	GRILL, FILTER	1
42	1015609	●FILTER KIT, EXHAUST, KIT=10	1
43	1015611	FILTER, FOAM	1
44	1016503	FILTER, H.E.P.A. (OPTIONAL)	1
45	1015622	CONVEYOR	1
46	1015610	●FILTER, MOTOR, PROTECTION	1
47	1015668	HOUSING, FILTER	1
48	1015598	HOUSING BAG, TENNANT	1
49	1015655	BRUSH, DUSTING	1
50	1015652	●WAND EXT., TELESCOPIC	1
51	1015654	TOOL, CREVICE	1

∇ ASSEMBLY / ENSEMBLE / CONJUNTO ● RECOMMENDED STOCK ITEM / ÉLÉMENTS DE STOCK RECOMMANDÉS / PIEZAS RECOMENDADAS EN ALMACÉN
 ▲ INCLUDED IN ASSEMBLY / Y COMPRIS EN ENSEMBLE / INCLUIDO A CONJUNTA

SINGLE MOTOR BASE GROUP

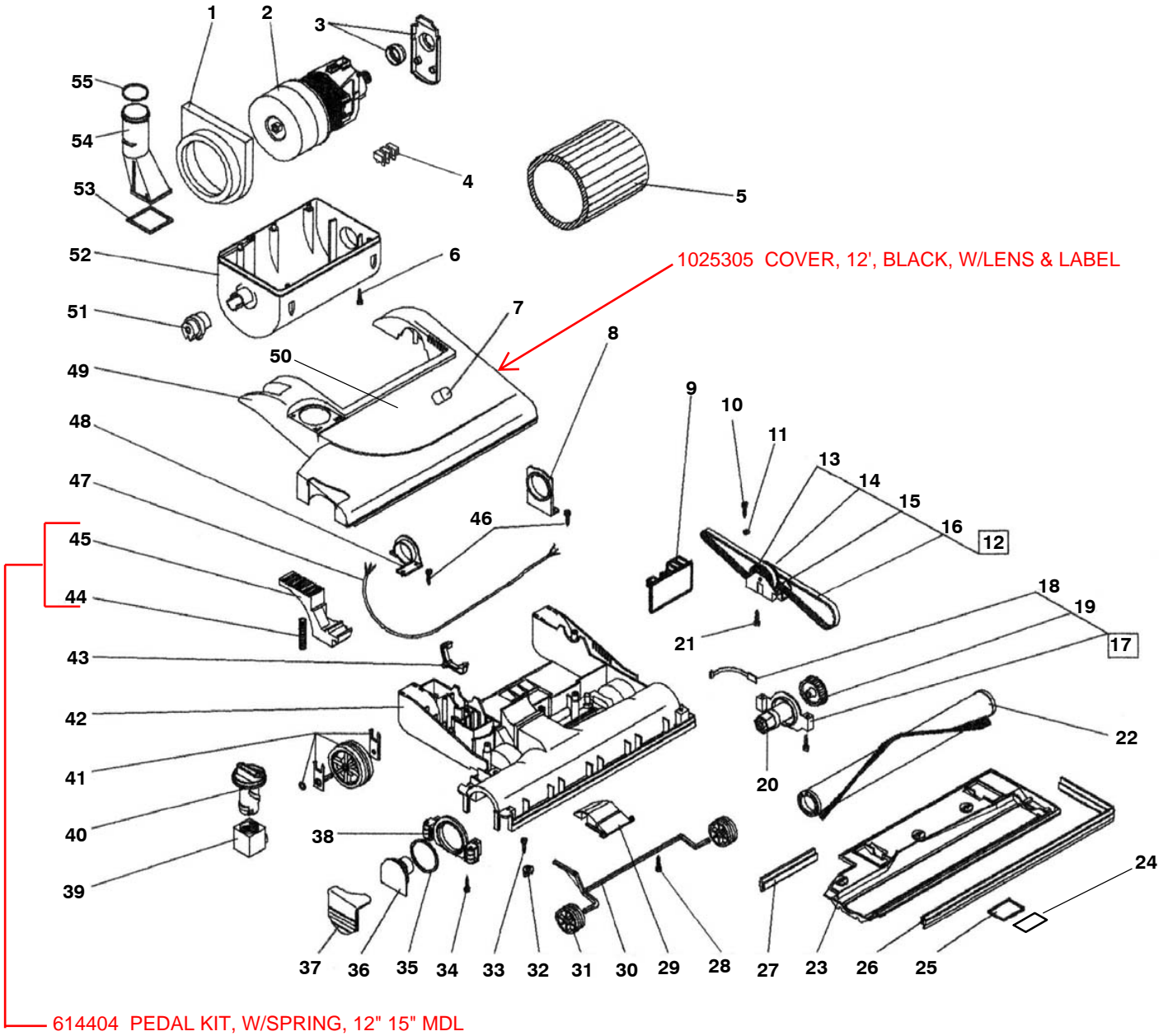

SINGLE MOTOR BASE GROUP

REF	PART #	DESCRIPTION	QTY.
1	1015658	GASKET, MOTOR	1
2	1015657	●MOTOR, VAC, W/PULLEY	1
3	1015659	GASKET, MOTOR, BRH HOLDER	1
4	1015645	TERMINAL BLOCK, 5 POLE	1
5	1015612	FILTER, MOTOR	1
6	1015727	SCREW KIT, 3.9X32, KIT=20 PCS	1
7	1015602	LENS KIT, RED/GREEN, KIT=2 PCS	1
8	1015671	SUPPORT, LEFT	1
9	1015656	●CIRCUITBOARD, SMU	1
10	1015718	SCREW KIT, 3.5X16, KIT=20 PCS	1
11	1015717	WASHER KIT, 3.5, KIT=20 PCS	1
▽ 12	1015681	●TRANS ASM., BELTS, PULLEYS	1
▲ 13	1015660	PULLEY ASM., DBL W/BEARINGS	1
▲ 14	1015706	PIN 5X28	1
▲ 15	1015661	SUPPORT PULLEY	1
▲ 16	1015662	●BELT, TIMING, 276 6MM, SMU	2
▽ 17	1015709	●SUPPORT ASM., BRUSH W/PULLEY & SENSOR	1
▲ 18	N/A	SPEED SENSOR	1
▲ 19	1015682	PULLEY, BSH, W/METAL INSERT	1
20	1015728	CLUTCH KIT, DRIVE	1
21	1015735	SCREW KIT, 3.9X1.3 TG, KIT=20 PCS	1
22	1015729	●BRUSH, 12" MODEL, ROLLER	1
	1015730	●BRUSH, 15" MODEL, ROLLER	1
▽ 23	1015700	SHOE, 12" MODEL, SMU W/LBLS	1
	1016388	SHOE, 15" MODEL, SMU W/LBLS	1
▲ 24	1016350	LABEL, SHOE, IMPORTANT	1
▲ 25	1016348	LABEL, SHOE, WARNING	1
26	1015703	BUMPER, 12" MODEL, FRONT	1
	1015704	BUMPER, 15" MODEL, FRONT	1
27	1015702	BUMPER, 15" MODEL, BACK	1

REF	PART #	DESCRIPTION	QTY.
28	1015723	SCREW KIT, 4.8X13 TG, KIT=20 PCS	1
29	1016387	COVER, CHANNEL SMU	1
30	1015757	AXLE, FRONT	1
31	1015697	WHEEL, FRONT	2
32	1015696	CLIP KIT, COVER, KIT=20 PCS	1
33	1015720	SCREW KIT, 3.5X9.5 TG, KIT=20 PCS	1
34	1015722	SCREW KIT, 3.9X25, KIT=20 PCS	1
35	1015694	SEAL, O-RING	1
36	1015693	SUPPORT, BRUSH	1
37	1015737	COVER, SIDE	1
38	1015695	SUPPORT ASM., SIDE W/WHEELS	1
39	1015691	BLOCK, BRUSH, ADJUSTER	1
40	1015690	KNOB, ADJUSTING	1
41	1015683	●WHEEL ASM., REAR	2
42	1015687	BASE, SINGLE MTR, 12" MDL	1
	1015644	BASE, SINGLE MTR, 15" MDL	1
43	1015686	LEVER, LIFT, BASE	1
44	1015685	SPRING, PEDAL	1
45	1015684	PEDAL, FOOT	1
46	1015725	SCREW KIT, 3.9X19, KIT=20 PCS	1
47	1015680	CORD, BASE	1
48	1015670	SUPPORT, RIGHT	1
49	1015675	COVER, 3110, 12" W/LENS & LBL	1
	1016386	COVER, 3110, 15" W/LENS & LBL	1
50	614273	LABEL, TENNANT 3110	1
51	1015669	PIVOT, LATCH	1
52	1015666	HOUSING, MOTOR	1
53	1015667	GASKET, CONVEYOR	1
54	1015664	TUBE, CONVEYOR	1
55	1015663	SEAL, O-RING	1

▽ ASSEMBLY / ENSEMBLE / CONJUNTO
 ▲ INCLUDED IN ASSEMBLY / Y COMPRIS EN ENSEMBLE / INCLUIDO A CONJUNTA

● RECOMMENDED STOCK ITEM / ÉLÉMENTS DE STOCK RECOMMANDÉS / PIEZAS RECOMENDADAS EN ALMACÉN

SINGLE MOTOR ELECTRICAL DIAGRAM (120V)

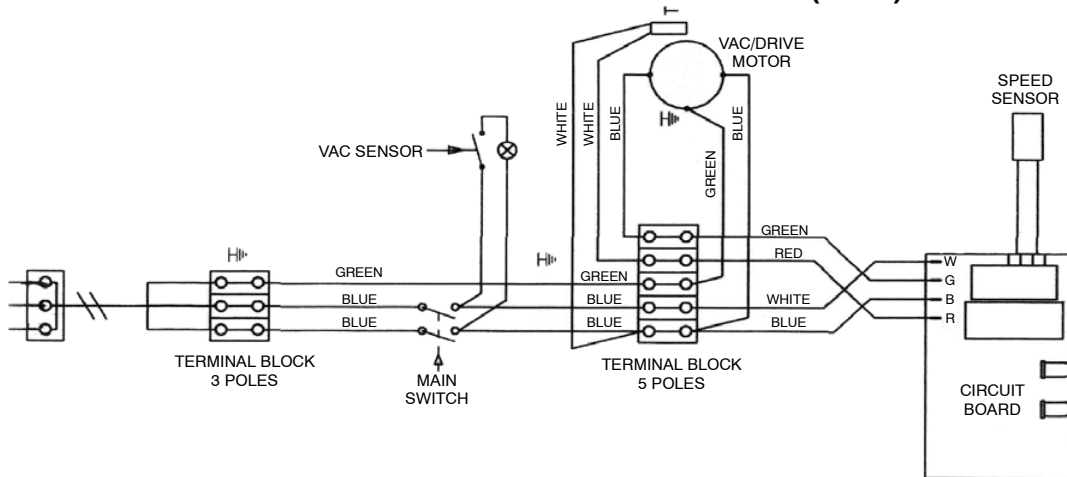

DUAL MOTOR BASE GROUP

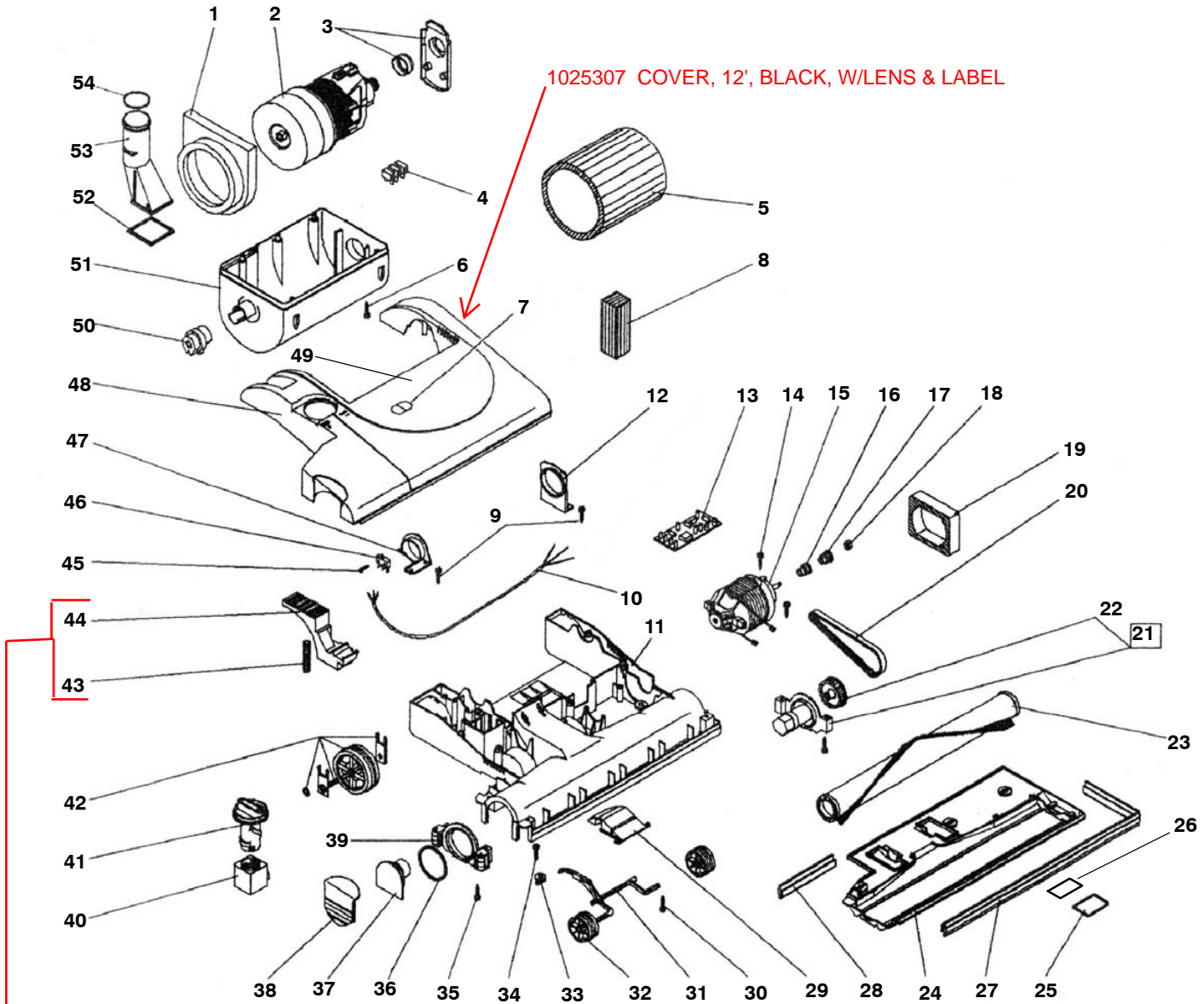

1025307 COVER, 12', BLACK, W/LENS & LABEL

614404 PEDAL KIT, W/SPRING, 12" 15" MODELS
 614405 PEDAL KIT, W/SPRING, 18" MODEL

43 614406 SPRING, PEDAL, 18"

DUAL MOTOR BASE GROUP

43 614406 SPRING, PEDAL, 18"

REF	PART #	DESCRIPTION	QTY.
1	1015658	GASKET, MOTOR	1
2	1015740	●MOTOR, VAC, W/BAL DISC	1
3	1015659	GASKET, MOTOR, BRH HOLDER	1
4	130005	TERMINAL BLOCK, 3 POLE	1
5	1015612	FILTER, MOTOR	1
6	1015727	SCREW KIT, 3.9X32, KIT=20 PCS	1
7	1015601	LENS KIT, RED/GREEN, KIT=2 PCS	1
8	1015747	FILTER	1
9	1015725	SCREW KIT, 3.9X19, KIT=20 PCS	1
10	1015746	CORD, BASE	1
11	1016509	BASE, DUAL MTR, 12" MODEL	1
	1015688	BASE, DUAL MTR, 15" MODEL	1
	1015749	BASE, DUAL MTR, 18" MODEL	1
12	1015671	SUPPORT, LEFT	1
13	1015739	●CIRCUITBOARD, DUAL MOTOR	1
14	1015725	SCREW KIT, 3.9X19, KIT=20 PCS	1
15	1015755	MOTOR, 12"/15" MDL, BRUSH 120V	1
	1015756	MOTOR, 18" MODEL, BRUSH 120V	1
16	1015741	SPACER	1
17	1015742	PINION	1
18	42368	NUT, M4	1
19	1015753	FILTER, MOTOR	1
20	1015743	●BELT, TIMING, 249 M7, DUAL MTR	1
▽ 21	1015754	SUPPORT ASM., BRSH W/PULLEY	1
▲ 22	1015682	PULLEY, BSH, W/METAL INSERT	1
23	1015729	●BRUSH, 12" MODEL, ROLLER	1
	1015730	●BRUSH, 15" MODEL, ROLLER	1
	1015748	●BRUSH, 18" MODEL, ROLLER	1
▽ 24	1016511	SHOE, 12" MODEL, DL MTR W/LAB	1
	1015701	SHOE, 15" MODEL, DL MTR W/LAB	1
	1015750	SHOE, 18" MODEL, DL MTR W/LAB	1
▲ 25	1016350	LABEL, SHOE, IMPORTANT	1
▲ 26	1016348	LABEL, SHOE, WARNING	1

REF	PART #	DESCRIPTION	QTY.
27	1015703	BUMPER, 12" MODEL, FRONT	1
	1015704	BUMPER, 15" MODEL, FRONT	1
	1015752	BUMPER, 18" MODEL, FRONT	1
28	1015702	BUMPER, 15" MODEL, BLACK	1
	1015751	BUMPER, 18" MODEL, BLACK	1
29	1015699	COVER, CHANNEL	1
30	1015723	SCREW KIT, 4.8X13 TG, KIT=20 PCS	1
31	1015698	AXLE, FRONT	1
32	1015697	WHEEL, FRONT	2
33	1015696	CLIP KIT, COVER, KIT=20 PCS	1
34	1015720	SCREW KIT, 3.5X9.5 TG, KIT=20 PCS	1
35	1015722	SCREW KIT, 3.9X25, KIT=20 PCS	1
36	1015694	SEAL, O-RING	1
37	1015693	SUPPORT, BRUSH	1
38	1015692	COVER, SIDE	1
39	1015695	SUPPORT ASM., SIDE W/WHEELS	1
40	1015691	BLOCK, BRUSH, ADJUSTER	1
41	1015690	KNOB, ADJUSTING	1
42	1015689	●WHEEL ASM., REAR	2
43	1015685	SPRING, PEDAL 12"-15"	1
44	1015684	PEDAL, FOOT	1
45	1015736	SCREW KIT, 2.2X16, KIT=20 PCS	1
46	1015738	●SWITCH	1
47	1015670	SUPPORT, RIGHT	1
48	1016508	COVER, 3120, 12" W/LENS & LBL	1
	1015678	COVER, 3120, 15" W/LENS & LBL	1
	1015745	COVER, 3120 18" W/LENS & LBL	1
49	614271	LABEL, TENNANT 3120 DM	1
50	1015669	PIVOT, LATCH	1
51	1015666	HOUSING, MOTOR	1
52	1015667	GASKET, CONVEYOR	1
53	1015664	TUBE, CONVEYOR	1
54	1015663	SEAL, O-RING	1

▽ ASSEMBLY / ENSEMBLE / CONJUNTO
 ▲ INCLUDED IN ASSEMBLY / Y COMPRIS EN ENSEMBLE /
 INCLUIDO A CONJUNTA

● RECOMMENDED STOCK ITEM / ÉLÉMENTS DE STOCK RECOMMANDÉS /
 PIEZAS RECOMENDADAS EN ALMACÉN

DUAL MOTOR ELECTRICAL DIAGRAM (120V)

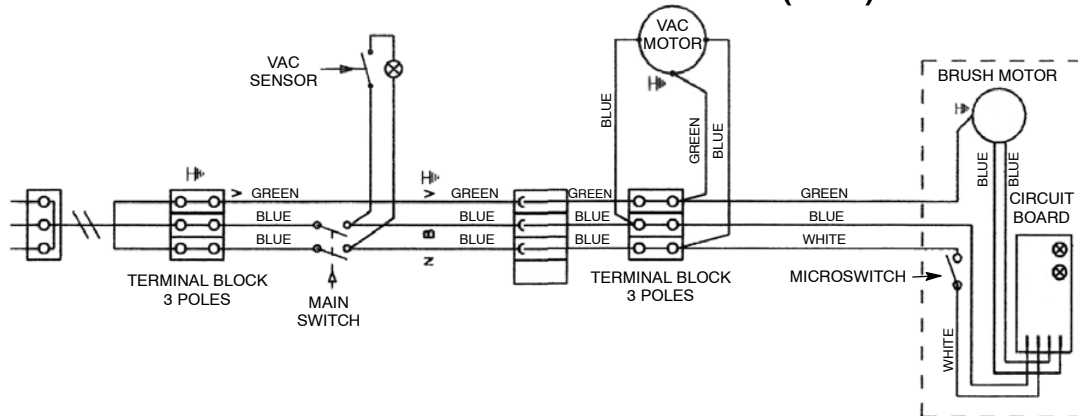



3110 and 3120 Upright Vacuum Cleaners

U.S. AND CANADIAN NEW MACHINE WARRANTY POLICY

Our Commitment to Customer Satisfaction

The warranty terms outlined below are in lieu of any other warranties, either expressed or implied, including any implied warranty of merchantability, fitness for a particular purpose or otherwise. Under no circumstances will seller be liable for any loss, damage, expense or consequential damages arising in connection with the use or inability to use, these products.

This warranty does not apply to damage or defect caused by accident, misuse, negligence, abuse, fire or to any Tennant product that has been serviced by anyone other than an authorized Tennant service representative. Housings or parts that have become damaged as a result of improper use of the machine are excluded from this warranty. Refer to Owner's Manual for proper machine use and maintenance. Parts that are expected to wear from normal use and, therefore, are not covered under the warranty include: handle, wheels, brush; filters; nozzles, hoses, switch, paper bags, power cord and motor carbon brushes.

This warranty commences on the date of purchase of the product by the original end user from an authorized Tennant sales representative, subject to proof of purchase. **A Machine Warranty Registration and Survey Reply Card included with the Owner's Manual must be completed and returned immediately at the time of purchase.** If proof of purchase date is unavailable, the warranty begins 90 days after the sale of the product to an authorized Tennant dealer.

Subject to the conditions outlined above, Tennant warrants the 3110 and 3120 models to be free from defects in materials and workmanship under normal use and service for one year, and further warrants, on a limited basis for three years, the belts and electric motors not subject to wear, to the original buyer. Electric motors subject to carbon brush wear, their durability depends on the numbers of hours of use and on the established substitution of filters. It does not depend on the years of life of the machine. The eventual substitution of the motor under warranty will therefore be effected only in case of production defect (this has to be verified by an authorized Tennant service center) and not in the case of total wear.

Parts replaced under this warranty are guaranteed for the remainder of the original warranty period or 90 days, whichever comes first, to the original end user.

Date Purchased: _____
Model Number: _____
Serial Number: _____

Please make sure to record this information. This information will be necessary for future warranty claims.

Tennant reserves the right to change its warranty policy without notice.