

# Dryer

Floor/Carpet Dryer

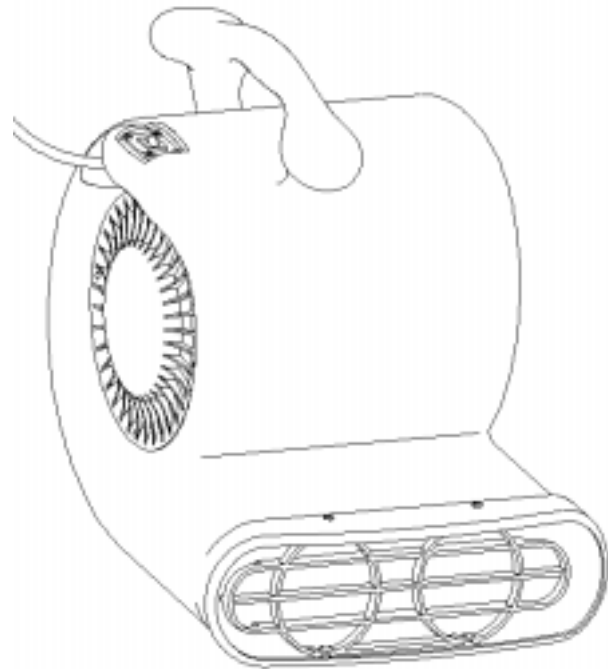

Owner's Manual



**TENNANT COMPANY**  
12875 RANSOM STREET  
HOLLAND MI 49424 U.S.A.

FAX: 1-800-678-4240  
CUSTOMER SERVICE: 1-800-522-7839

**608797**  
**Rev. 01 (08-04)**

# TABLE OF CONTENTS

SAFETY INFORMATION .....	2
DRYER FEATURES .....	3
PRINCIPLES OF DRYING .....	3
Airflow Circulation.....	3
Humidity Control.....	3
DRYING PROCEDURES .....	4
Subsurface Carpet Drying.....	4
Surface Drying.....	4
Stapling Down .....	4
Adjusting Airflow.....	4
Gluedown Carpets.....	4
Loose Lay Rugs.....	4
Application of Deodorants.....	5
COOLING & VENTILATION .....	5
ELECTRICAL CONNECTIONS .....	5
MAINTENANCE .....	5
RECOMMENDED STOCK ITEMS .....	5
SPECIFICATIONS .....	6
PARTS LIST .....	8
TROUBLESHOOTING .....	8

**Congratulations** on your purchase of this Dryer. It is our goal to offer you the best high performance airmover available. Your Dryer is durable, simple to operate and can provide years of trouble free service when you follow the recommendations listed in this manual.

We strongly advise that you read this manual before unit operation. Please pay particular attention to the safety information. We invite your written comments and suggestions for improvements. If you do not understand something in this manual or if you have a question about your Dryer , call our Customer Service Department at 1-800-522-7839.

## SAFETY INFORMATION

### SAVE THESE WARNINGS

The manufacturer is concerned about the safety of everyone who uses or comes in contact with the Dryer. The Dryer is designed to be operated in compliance with the safety warnings and instructions provided in this manual.

Like other electrical devices, Dryers can become dangerous if abused, damaged or misused. Failure to observe the following warnings can result in injury to persons, fire damage, or damage to the Dryer. To reduce the risk of electrical shock, fire, or personal injury, read and follow each of the warnings below before using Dryers.

**Keep Dryers Grounded:** Always operate Dryers with the three pronged grounding plug and a grounded electrical outlet. Never remove the three pronged plug, use an ungrounded extension cord or an ungrounded adapter. The grounding prong on the Dryer’s plug is an essential safety feature that helps reduce the risk of shock or fire in the event of an electrical hazard.

### DANGER

Removal or alteration of the grounding plug, or use of an adapter that defeats the Dryer’s electrical grounding, can create risk of serious personal injury or fire in the event of damage to or malfunction of this product. Do not use Dryers for any reason if they cannot be properly grounded. If you are unsure whether a receptacle is grounded, test the outlet with a receptacle tester or consult an electrician.

**Extension Cords:** Extension cords must be grounded and be able to deliver the appropriate voltage to the Dryer. For use with the Dryer, an extension cord up to 25 feet in length must have 14 AWG wire; a cord up to 50 feet in length must have 12 AWG wire.

### CAUTION

Never operate Dryers in pooled or standing water, as this may create a risk of serious injury from electrical shock.

**Protect the Power Cord From Damage:** Never operate Dryers with cut, nicked, abraded, frayed or otherwise damaged power cords or extension cords as this may lead to electrical or fire hazards. Never unplug the Dryer by pulling the cord. Grasp the plug firmly and pull straight out. Take precautions not to use the cord in a way where damage may occur. Keep cords away from heated surfaces. Inspect cords before each use and replace cords that show signs of damage.

**Storage:** Store Dryers in a clean dry environment. Do not store Dryers outdoors.

**Keep Motor Dry:** Never allow water inside the Dryer’s motor. If the motor becomes wet for any reason, thoroughly dry it before use.

**Keep Children Away:** Do not allow children to play with or around the Dryer. Be sure the Dryer is inaccessible to children when unattended. Children can hurt themselves by playing with or around Dryers. Secure all areas in which Dryers are left unattended while running.

**Handle With Care:** Do not drop or throw Dryers for any reason. Rough treatment can damage the motor, wiring or motor mount and safety screens and create a hazardous condition.

**Run on Stable Surface:** Always operate Dryers on a stable flat surface such as the floor. Do not operate Dryers from places where they can fall or be pulled down causing injury. Beware that Dryers may vibrate or be pulled from smooth surfaces such as counter tops and cause an injury, fire or electrical hazard.

#### WARNING

To reduce the risk of fire or electric shock, do not use Dryers with a solid-state speed control device.

**Air Intakes Must Be Clear:** Operate Dryers away from draperies and other materials that may come in contact with the air intakes. Do not allow any material to clog or block air intakes, as this may cause Dryers to overheat and result in a fire or electrical hazard.

**Keep Foreign Matter Out:** Do not allow oil, grease, solvents or other matter (including sawdust and drywall dust) to be drawn into the air intakes of Dryers. Never direct fogged or liquid chemicals of any kind into the air intakes of Dryers.

#### CAUTION

Never operate Dryers in pooled or standing water, as this may create a risk of serious injury from electrical shock.

**Don't Operate Without Safety Screens:** Never operate Dryers without the factory installed safety screens on the air inlets and air exhaust as the rapidly revolving wheel can cause serious injury.

**Keep Away From Heaters:** Do not use Dryers for circulating hot air by placing the intakes close to a heater. The housing could melt or the motor could overheat and cause a fire or electrical hazard.

**Keep Away From Combustible Gas:** Do not operate Dryers in an area containing combustible gas. This could cause a danger of fire or explosion. Ventilate environments that may be explosive.

**Don't Modify Unit:** Never modify the motor, wiring or casing of Dryers for any reason. Modifications to Dryers can lead to fire or electrical hazards.

**Share Owners Manual:** Be sure to include a copy of the Dryer Owners Manual whenever you loan, rent, or otherwise allow someone else to use your Dryers. They need the same safety information that you require for safe efficient operation. Make sure that all technicians and operators have read and understand the manual.

**Maintenance or Repair:** Do not attempt to disassemble or repair Dryers if you are not qualified to do so. If the Dryer is not working as it should, return it to an authorized dealer or distributor for servicing. Note: For information about authorized repair and maintenance call our Customer Service Department at 1-800-522-7839.

#### DANGER

Do not attempt to service or clean the Dryer while it is plugged into an electrical outlet or while the wheel is turning as this may lead to risk of electrical shock or injury. It is dangerous for an unqualified individual to attempt to disassemble or repair the Dryer.

## DRYER FEATURES

Dryers feature durable polyethylene housings, durable switches and handles, and molded venturi air inlets. Metal parts are treated for corrosion resistance. The efficient motors reduce energy consumption and the engineered four point motor mount is extremely durable. You may find that they operate more quietly, last longer and deliver greater airflow and static performance than competitive airmovers.

## PRINCIPLES OF DRYING

Given any drying situation, there are three factors that can be managed for fast successful drying: temperature, air movement and humidity control.

#### IMPORTANT NOTE

It is not within the scope of a users guide to teach restoration. The information in this manual should serve as a reference only. It is strongly recommended that IICRC Certification courses be completed before water damage restoration is attempted.

### Airflow Circulation

Dryers are designed to deliver a high volume laminar airflow over or under wet surfaces for speed drying. Airflow speeds the rate of evaporation, helps prevent mold growth, and reduces the risk of secondary damage. Circulating air speeds evaporation by removing the "boundary layer" of saturated air that hangs near wet surfaces. The moist air is whisked away and replaced with dryer air.

Place at least one Dryer in each room or one for every 200 square feet. For best results when walls are wet, place one Dryer for each 8-10 feet of wall, pointed toward the wall at a 45-degree angle, with all Dryers pointed in the same circle around the walls to create a vortex of airflow that will reach all surfaces in the room.

Ensure that all affected areas have good airflow. Open doors and operate Dryers to maintain good air circulation. Doors may need to be braced to prevent them from closing as a result of air movement.

#### WARNING

Do not, under any circumstances, remove the grounding plug from the cord. To do so may create a safety hazard and void the warranty.

## Humidity Control

Using Dryers to speed the rate of evaporation in an enclosed area can cause humidity to escalate. As humidity elevates, airmovers become less effective and the rate of drying slows. It is vital that Dryers be used with adequate dehumidification. For safety, indoor humidity should not exceed 60% Rh. For maximum drying of porous materials, indoor humidity should be maintained below 45% Rh. Even lower humidity between 25-40% Rh is helpful for drying saturated, dense materials such as walls and floors.

To assist in the drying process, close off the building area being dried from the rest of structure. Regulate the heating or air conditioning system of the structure. When dehumidifiers are not available, turn on exhaust fans in the attic, kitchen and bathroom to remove some humidity. Use a thermo-hygrometer such as the DHT200 or DHT600 to determine the indoor relative humidity.

## DRYING PROCEDURES

It is possible to dry both the stretched in carpet and synthetic cushion at the same time on many flood jobs. Dryers are used to force air under the carpet so that a cushion of air floats the carpet off the floor. Along with humidity control, the high volume airflow will usually dry most carpet, cushion, and flooring.

When hardwood flooring is present under wet carpet, strong consideration should be given to removing carpet for drying. Consideration should also be given to removing water damaged carpet cushion when it has a non-porous plastic "skin", when it shows signs of severe wear or in contaminated situations.

### Sub-surface Carpet Drying

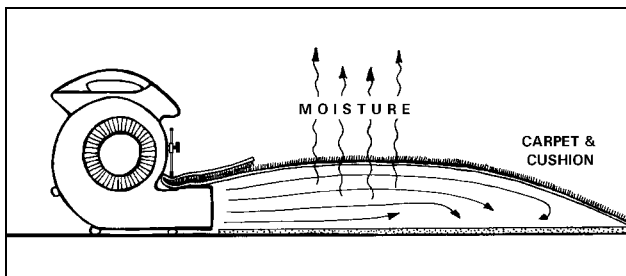

*Dryer with Carpet Clamp.*

For most subsurface drying, place Dryers in a corner or door opening. Place the snout of the Dryer between the carpet and cushion. For subsurface carpet drying, the carpet must be disengaged and folded back several feet. Place the airmover snout below the carpet edge and staple through the tackless on both sides of the Dryer. Note the condition of the tackless strip, cushion and floor. They may require additional procedures.

### Stapling Down

After placing the dryer, staple through the tack strip on both sides of the dryer. This is done to keep the carpet from floating off the tackless and losing float. To relieve

excess pressure, open an opposite corner and staple as if placing a dryer.

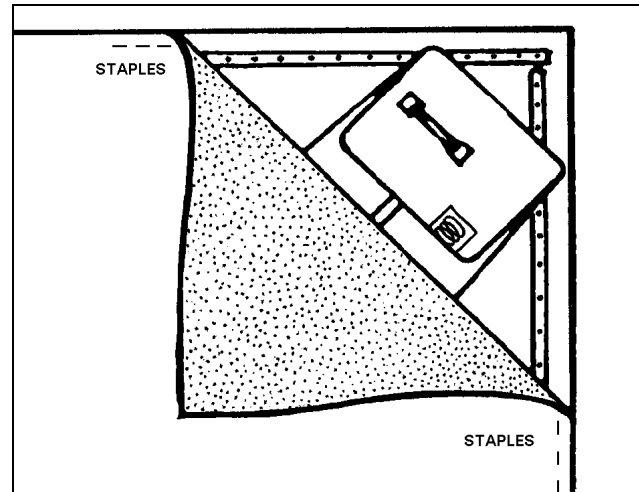

### Adjusting Airflow

When adjusting the volume of air under the carpet, care should be exercised to not force too much air into the space. Too much air volume may disengage the carpet from the tackless strip and tear it as it comes off the strip.

If the carpet is a tightly stretched installation, the carpet may stretch if too much air is forced under it, and the stretching may cause difficulty in the final steps of reinstallation. Air pressure can be relieved by releasing the carpet from the tackless strip at the opposite side from the Dryer until the proper lift has been attained.

### CAUTION

Increased air movement and evaporation without proper dehumidification may result in extremely saturated air. Drywall and other hygroscopic materials may absorb the excess moisture in the air. This can result in "secondary damage" to materials. When using Dryers, monitor humidity levels and use dehumidifiers as required. Maintain the humidity below 60% Rh at all times.

### Surface Drying of Carpet and Walls

In some cases, stretched-in carpet, pad and subfloor can be dried from the surface, without disturbing the installation in any way except lifting corners of carpet to inspect.

Factors for success in surface drying include: exceptionally complete extraction, use of enough Dryers strategically placed to create constant airflow across all affected areas, use of enough dehumidifiers to quickly and constantly maintain a lowering of humidity in the drying area, and careful monitoring with adequate moisture and humidity meters.

The advantages of surface drying include less restretching, repair and replacement of materials, fewer problems with difficult types of carpet, less disturbance of furniture and contents, greater reliance on equipment rather than labor (except that extraction may take more time to guarantee

that it is more complete), greater profitability, and less overall time and expense on the job when successful. The disadvantages may include greater use of equipment and electrical power, and a greater possibility of incomplete drying if the job is not adequately set up and monitored.

### Gluedown Carpets

Do not attempt to lift corners when carpet is glued directly to a subfloor. Glued rubber or foam backed carpet is best dried from the surface if replacing it is avoided. As in any surface drying place Dryers where the airflow will cover the most surface area, either directly or by causing a circular "vortex" of air that keeps flowing across all surfaces.

If appropriate, instruct the customer on how to turn off the Dryer and move it every few hours until the carpet is dry. Again, carpet drying will be most rapid when the extraction process has been thorough, proper humidity levels are maintained and sufficient Dryers are used.

### Loose Lay Rugs

Loose lay rugs may be dried on the customer's premises, in your plant or in a garage. A loose lay rug with separate cushion may be dried by placing a dryer between the carpet and cushion on one end while placing another dryer between the cushion and floor on the opposite end. Use the carpet clamp to attach the carpet to the airmover to prevent it from blowing off the snout.

## COOLING & VENTILATION

Hot humid rooms can be cooled with the high volume airflow from a Dryer. Simply place the airmover on the floor or other flat surface and direct the air from the Dryer outside or towards cooler areas. Use the kickstand or the 45-90 degree tilt feature to elevate the snout and circulate cool air throughout the room.

#### CAUTION

Be careful not to position Dryers in such a way as to blow wall hangings and other items off the walls.

## ELECTRICAL CONNECTIONS

Dryers are designed to operate on a 115V/60 Hz electrical connection. Make sure that the electrical outlet is grounded and that all safety precautions are taken.

## MAINTENANCE

Always turn off the power before performing maintenance procedures. All the service procedures below are to be executed with the unit unplugged. Perform before each use or as needed.

**Cord Inspection:** Inspect the electrical cord for damage. Units with damaged cords must be removed and repaired before use. Failure to do so may lead to electrical shock, or a fire hazard.

**Clean Air Intakes:** Clean the air inlet side screens of any accumulated lint and or fabric. A buildup will reduce the airflow and may cause the motor to overheat and become a fire hazard.

#### CAUTION

Do not over tighten screws when reinstalling the plastic air inlet side screens on Sahara models, as this may cause them to crack.

**Clean Exterior:** Clean the exterior plastic housing with mild detergent and water. Bring back the original shine with Armor-All or similar cleaner-shiner.

**Exterior Inspection:** Evaluate exterior components and make sure that exterior components are properly installed. Repair or replace missing components as required. Listen to the unit for abnormal sounds and repair as needed.

#### YEARLY

Make sure unit is unplugged and the wheel has stopped. Remove the four side screen screws on each side and remove the side screens. This will permit access to motor and wheel for cleaning.

**Clean Blower Wheel:** Remove lint and dust. Use a vacuum or air hose to vacuum or blow lint and dust from blower wheel, motor and side screens.

**Motor Bearings:** The bearings are permanently lubricated. No oiling is necessary.

#### CAUTION

Internal repair procedures should be performed by a qualified technician from an authorized service center.

## RECOMMENDED STOCK ITEMS

Refer to Parts list on page 7 for recommended stock items. Stock items are clearly identified with a bullet preceding the parts description.

## DRYER SPECIFICATIONS

<b>Switch</b>	2-Speed Rocker	
<b>RPM</b>	800 - 1050 rpm	
<b>Rated CFM</b>	2000 cfm	3400 cmh
<b>Power Draw, 115 Volts</b>	7.5 amps	
<b>Carpet Clamp</b>	Kit Available	
<b>Wheel</b>	9.5" x 9.5"	24 x 24 cm
<b>Height, Width, Length</b>	19", 17", 19"	47 cm, 42 cm, 39 cm
<b>Use Weight</b>	25 lb	11 kg
<b>Ship Weight</b>	30 lb	14 kg
<b>Motor Rating</b>	.25 hp	
<b>Overheating Cutoffs</b>	Dual Thermal Protectors	
<b>Safety Listings</b>	UL-CUL	

*Specifications are subject to change without notice.*

**FOR PARTS AND SERVICE CALL YOUR LOCAL DISTRIBUTOR,  
OR OUR CUSTOMER SERVICE DEPARTMENT AT 1-800-522-7839**

## EXPLODED VIEW

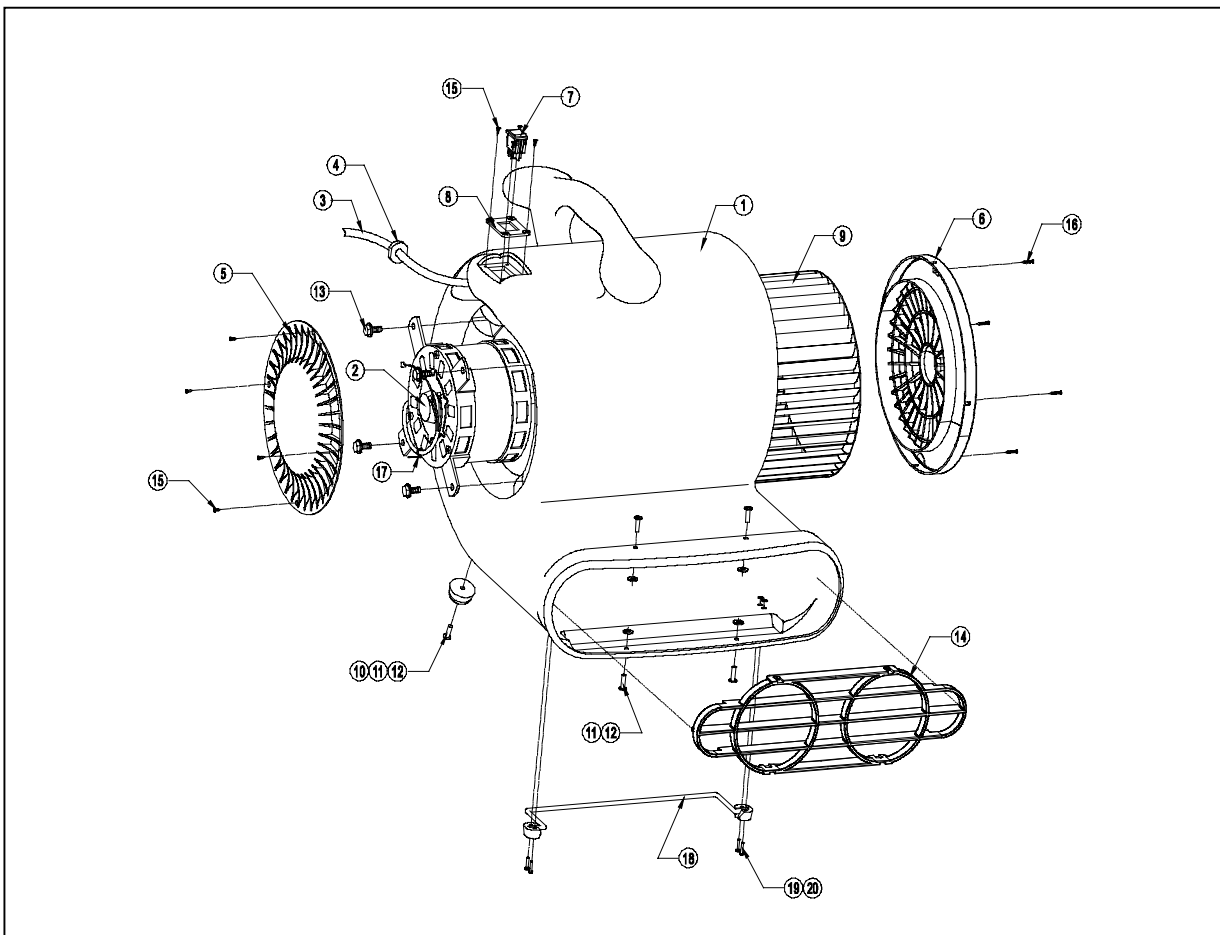

## PARTS LIST

1	611989	HOUSING – POLYETHYLENE BLACK
2	608805	• MOTOR ASSEMBLY – 115V 1/4 HP 1050 RPM 2-SPD
3	608804	• POWER CORD ASSEMBLY – 16/3 SJTW SJTW-A 5-15P 25FT
4	608803	• STRAIN RELIEF – SNAP .370 BLACK
5	608802	• MOTOR SIDE GRILL – ABS BLACK
6	608800	• INLET SIDE GRILL – ABS BLACK
7	608799	• SWITCH – ROCKER SPDT RED
8	611994	SWITCH PLATE – ABS BLACK
9	611995	BLOWER WHEEL – CENTRIFUGAL 9.5 X 9.5 GALV STEEL
10	608798	• FOOT – ROUND 3/8 ID X 1.25 OD X 5/8 RUBBER BLACK
11	611996	RIVET – 3/16 X 5/8 AL/AL BLACK ANODIZED
12	611997	WASHER – 3/16 RIVET .19 ID X .47 OD X .05 ZP
13	611998	SCREW – 1/4-20 X 3/8 HWH NYLOC ZINC
14	611999	SNOUT GRILL – ABS BLACK
15	612000	SCREW - #6 X 3/8 PHILLIPS PH ZP
16	612005	SCREW - #6 X 7/8 PHILLIPS PH ZP
17	612006	CABLE TIE – NYLON 4"
18	612007	KICKSTAND ASSEMBLY
19	612014	RIVET – 1/8 X 1/2 AL/AL
20	612016	WASHER – 1/8 RIVET 1/8 ID X 3/8 OD X .06 ZP

• Recommended Stocking Items

# DRYER TROUBLESHOOTING

**WARNING: ALL THE SERVICE PROCEDURES BELOW SHOULD BE EXECUTED WITH POWER OFF I.E. UNPLUGGED.**

<p><b>Motor won't run.</b></p>	<ol style="list-style-type: none"> <li>1. Switch not turned on.</li> <li>2. Circuit is overloaded and panel circuit breaker tripped.</li> <li>3. No power at outlet.</li> <li>4. Intake screens or exhaust snout is blocked.</li> <li>5. Switch is broken.</li> <li>6. Loose wiring.</li> <li>7. Blower wheel completely jammed.</li> </ol>	<ol style="list-style-type: none"> <li>1. Turn switch to appropriate speed</li> <li>2. Unload circuit and reset circuit breakers.</li> <li>3. Check panel circuit breaker and check outlet with receptacle tester.</li> <li>4. Turn machine off, allow to cool; remove blockage and reset breaker.</li> <li>5. Contact Service Center</li> <li>6. Contact Service Center</li> <li>7. Contact Service Center</li> </ol>
<p><b>Motor runs but wheel turns erratically and makes a scraping noise.</b></p>	<ol style="list-style-type: none"> <li>1. Severe jolt has caused motor mount to bend and blower wheel to rub against mount.</li> <li>2. Severe jolt has caused motor to slip out of mount and blower wheel to rub against housing.</li> </ol>	<ol style="list-style-type: none"> <li>1. Contact Service Center</li> <li>2. Contact Service Center</li> </ol>
<p><b>Airmover vibrates excessively.</b></p>	<ol style="list-style-type: none"> <li>1. Uneven accumulation of soil has built up on wheel.</li> <li>2. Blower wheel has been bent.</li> <li>3. Blower wheel has lost balance.</li> <li>4. Bent motor shaft.</li> </ol>	<ol style="list-style-type: none"> <li>1. Clean blower wheel.</li> <li>2. Contact Service Center</li> <li>3. Contact Service Center</li> <li>4. Contact Service Center</li> </ol>

**FOR PARTS AND SERVICE CALL YOUR LOCAL DISTRIBUTOR, OR OUR CUSTOMER SERVICE DEPARTMENT AT 1-800-522-7839**