

FLOOR-EQUIPMENT-PARTS.COM



1100

Portable Carpet Extractor

Model No.:
607721
607729 – Pac

Operator and Parts Manual

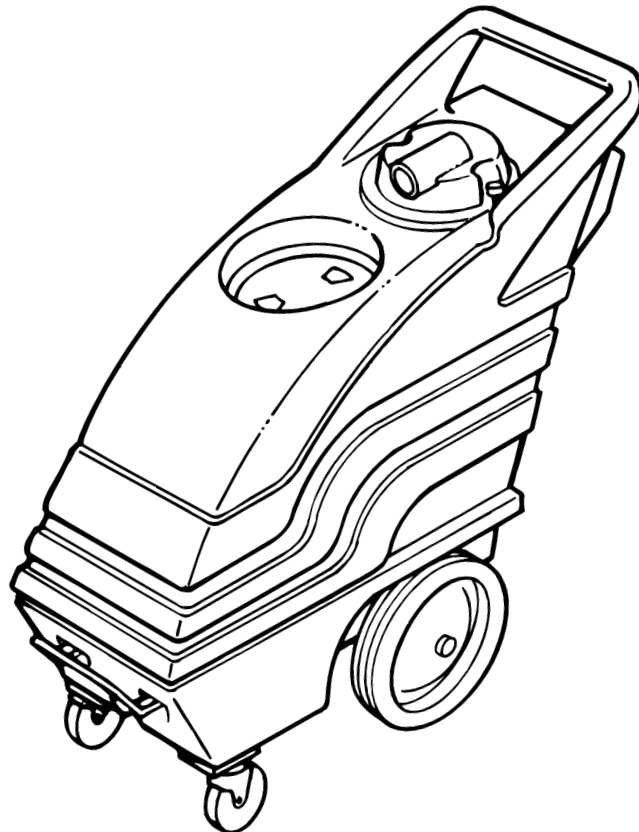

TENNANT COMPANY
Commercial Products
12875 RANSOM STREET
HOLLAND MI 49424 U.S.A.

FAX: 1-800-678-4240
CUSTOMER SERVICE: 1-800-982-7658

607722
Rev. 00 (11-99)

OPERATION

This manual is furnished with each new model. It provides necessary operation and maintenance instructions and an illustrated parts list.

Read this manual completely and understand the machine before operating or servicing it.

Use the illustrated Parts Lists to order parts. Before ordering parts or supplies, be sure to have your machine model number and serial number handy. Parts and supplies may be ordered by phone or mail from any authorized parts and service center, distributor or from any of the manufacturer's subsidiaries.

This machine will provide excellent service. However, the best results will be obtained at minimum costs if:

- The machine is operated with reasonable care.
- The machine is maintained regularly - per the machine care instructions provided.
- The machine is maintained with manufacturer supplied or equivalent parts.

MACHINE DATA

Please fill out at time of installation for future reference.

Model No.- _____

Install. Date - _____

Serial No.- _____

©1999 Tennant Company

Printed in U.S.A.

TABLE OF CONTENTS

SAFETY PRECAUTIONS	3
MACHINE COMPONENTS	4
MACHINE SETUP	4
MACHINE OPERATION	5
DRAINING RECOVERY TANK	6
MAINTENANCE	6
STORING MACHINE	7
TROUBLE SHOOTING	8
SPECIFICATIONS	9
PARTS LIST	10
ELECTRICAL DIAGRAM	16
OPTIONAL PARTS	17

SAFETY PRECAUTIONS

This machine is suited to clean carpet and upholstery in an indoor environment and is not constructed for any other use. Use only recommended accessory tools and cleaning solutions.

All operators must read, understand and exercise the following Important Safety Instructions.

The following safety alert symbols are used throughout this manual as indicated in their description.

⚠ WARNING: To warn of hazards or unsafe practices which could result in severe personal injury or death.

FOR SAFETY: To identify actions which must be followed for safe operation of equipment.

The following information signals potentially dangerous conditions to the operator or equipment:

FOR SAFETY:

1. **Do not operate machine:**
 - Unless trained and authorized.
 - Unless operator manual is read and understood.
 - In flammable or explosive areas unless designed for use in those areas.
 - With damaged cord or plug.
 - If not in proper operating condition.
 - In outdoor areas.
 - In standing water.
 - With the use of additional extension cords. Only use manufacturer's extension cord supplied with machine which has proper capacity and is grounded.
2. **Before operating machine:**
 - Make sure all safety devices are in place and operate properly.
3. **When using machine:**
 - Do not run machine over cord.
 - Do not pull machine by plug or cord.
 - Do not pull cord around sharp edges or corners.
 - Do not unplug by pulling on cord.
 - Do not stretch cord.
 - Do not handle plug with wet hands.
 - Keep cord away from heated surfaces.
 - Report machine damage or faulty operation immediately.
 - Follow mixing and handling instructions on chemical containers.

4. **Before leaving or servicing machine:**
 - Turn off machine.
 - Unplug cord from wall outlet.
5. **When servicing machine:**
 - Unplug cord from wall outlet.
 - Avoid moving parts. Do not wear loose jackets, shirts, or sleeves.
 - Use manufacturer supplied or approved replacement parts.

⚠ WARNING: Hazardous Voltage. Shock or electrocution can result. Always unplug machine before servicing.

⚠ WARNING: Flammable materials can cause an explosion or fire. Do not use flammable materials in tank(s).

⚠ WARNING: Flammable materials or reactive metals can cause an explosion or fire. Do not pick up.

GROUNDING INSTRUCTIONS

Machine must be grounded. If it should malfunction or breakdown, grounding provides a path of least resistance for electrical current to reduce the risk of electrical shock. This machine is equipped with a cord having an equipment-grounding conductor and grounding plug. The plug must be plugged into an appropriate outlet that is properly installed in accordance with all local codes and ordinances. Do not remove ground pin; if missing, replace plug before use.

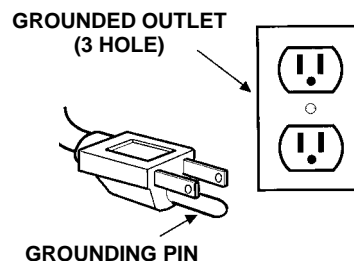

OPERATION

MACHINE COMPONENTS

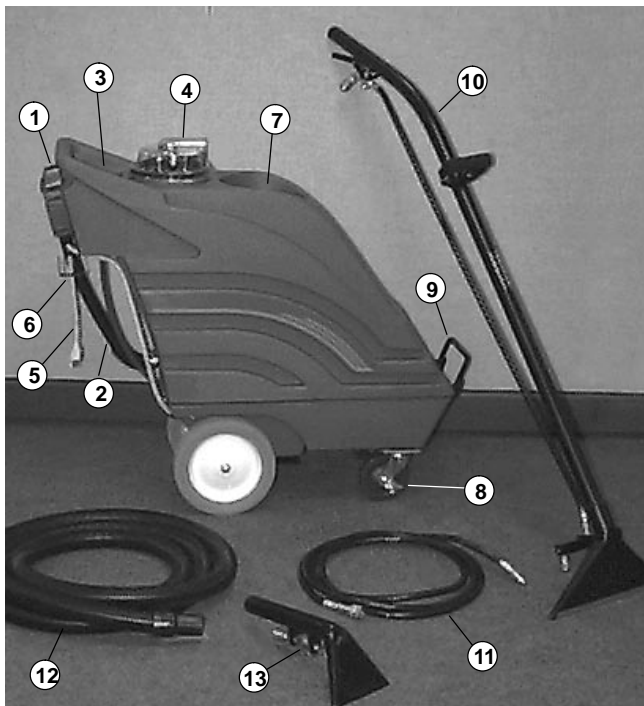

- | | |
|---|-------------------------------------|
| 1. ON/OFF Switch | 7. Solution Tank Lid |
| 2. Drain Hose | 8. Lockable Casters |
| 3. Solution Hose Connector | 9. Lift Handle/Hose Guide |
| 4. Recovery Dome/Vacuum Hose Connection | 10. Floor Tool |
| 5. Power Cord | 11. 4.6m (15 ft) Solution Hose |
| 6. Cord Store Hook | 12. 4.6m (15 ft) Vacuum Hose |
| | 13. Optional 127mm (5 in) Hand Tool |

MACHINE SETUP

PRE-OPERATION

1. Vacuum the floor to remove particles and other debris.
2. Inspect power cord for damage.

FILL SOLUTION BLADDER

1. Unscrew and remove flat clear lid. Fill solution bladder with 38 liters (10 gal) of hot water, 60°C (140°F) maximum (*Figure 1*).



FIG. 1.

2. Add recommended cleaning agent to proper dilution ratio.

FOR SAFETY: When using machine, follow mixing and handling instructions on chemical containers.

⚠ WARNING: Flammable materials can cause an explosion or fire. Do not use flammable materials in tank(s).

3. After filling solution bladder, replace lid and tighten securely.

NOTE: Suction in recovery tank will overexpand solution bladder if lid is not secure.

ATTENTION: If using powered chemicals, do not mix chemicals in solution bladder. Mix powdered chemicals thoroughly in a bucket before pouring into machine. Powders are unlikely to dissolve completely and can clog solution pump system.

ATTENTION: Use separate buckets to fill and empty extractor. Use a clean bucket to fill machine, and empty dirty water into a separate bucket. Dirty water in solution bladder will clog solution pump system.

4. Connect vacuum hose to recovery dome and solution hose to quick coupler located in front of handle (*Figure 2*).

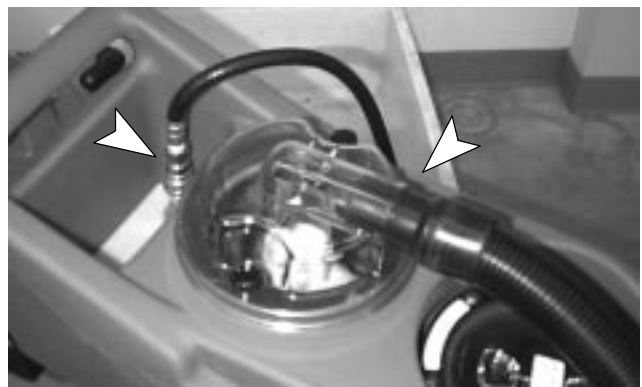

FIG. 2.

5. Route hoses through front lift handle (*Figure 3*).



FIG. 3.

NOTE: Routing hoses through handle will allow easy machine mobility while operating cleaning tool.

6. Attach recommended cleaning tool to opposite end of hoses.
7. If desired, lock front casters to keep machine from moving.
8. Plug extension power cord into machine and then plug into a grounded wall outlet (Figure 4).

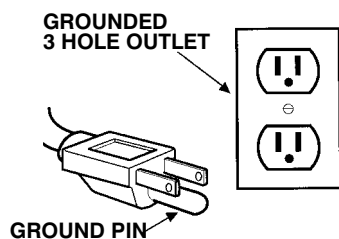

FIG. 4.

FOR SAFETY: Do not operate machine with the use of additional extension cords. Only use manufacturer's extension cord supplied with machine which has proper capacity and is grounded.

MACHINE OPERATION

FOR SAFETY: Do not operate machine unless operator manual is read and understood.

FLOOR TOOL OPERATION

1. Activate ON/OFF switch to "ON".
2. Place floor tool so bottom of stainless steel shoes are parallel to floor. Squeeze trigger and apply downward pressure on floor tool head and slowly pull tool backwards using both hands. Release trigger 150 mm (6 in) from end of stroke (Figure 5).



FIG. 5.

3. Push floor tool forward over same path with trigger released when returning for next stroke. Continue this pull and push method with a slight overlap of each stroke.

NOTE: For heavily soiled areas, repeat stroke or change angle of stroke.

⚠ WARNING: Flammable materials or reactive metals can cause an explosion or fire. Do not pick up.

ATTENTION: Do not allow water or foam to enter float shut-off screen in recovery tank. Screen will not stop foam intake and vacuum motor damage will result (*not covered by warranty*). If foam develops, remove dome and pour 29.6 ml (1 oz) of anti-foam solution into recovery tank.

HAND TOOL OPERATION

NOTE: This machine cleans most synthetic upholstery very well. Fabrics like Herculon and synthetic velvets will clean with excellent results. Extraction is not recommended for most cottons, silks, wools or natural fiber velvets. Check cleaning instructions sewn in furniture by manufacturer for further instructions. Extra caution should be taken with furniture that has been reupholstered. Any material under new upholstery may bleed and discolor new fabric.

1. Vacuum upholstery before cleaning.
2. Test fabric for colorfastness: Pour a small amount of cleaning solution on a white cloth and hold damp portion of cloth against an area of upholstery which is hidden from view. Hold cloth in place for one minute. If color does not transfer to cloth it should be safe to clean. However, always use your best judgement.
3. Activate ON/OFF switch to "ON".

OPERATION

- Place hand tool on furniture and squeeze trigger while applying a downward pressure on hand tool head and slowly pull tool backwards. Release trigger just shy from end of stroke (*Figure 6*).



FIG. 6.

NOTE: Be careful not to over wet upholstery. Overlap strokes to avoid streaking. Repeat stroke using only vacuum to get fabric as dry as possible.

⚠ WARNING: Flammable materials or reactive metals can cause an explosion or fire. Do not pick up.

ATTENTION: Do not allow water or foam to enter float shut-off screen in recovery tank.

AFTER CLEANING

- When finished cleaning, turn off switch, unplug power cord and drain and rinse out recovery tank.
- Disconnect solution and vacuum hoses and extension cords from machine. Neatly coil hoses and cord after each use.

ATTENTION: Relieve water pressure from tool before disconnecting hose. Squeeze trigger for five seconds *after* turning off switches.

DRAINING RECOVERY TANK

NOTE: When solution bladder becomes empty while cleaning, recovery tank must be emptied.

- Turn switch off and disconnect power cord.

FOR SAFETY: When servicing machine, unplug cord from wall outlet.

- Remove drain hose from holder, position a discharge bucket under drain hose and twist off drain hose knob (*Figure 7*).



FIG. 7.

NOTE: Do not use same bucket for filling clean water bladder!

- Replace drain hose knob tightly before cleaning again.
 - After final draining, remove recovery dome and rinse both tank and dome thoroughly to prevent odor buildup.
-

MAINTENANCE

To keep machine in good working condition, simply follow machines daily, weekly and monthly maintenance procedures.

⚠ WARNING: Hazardous Voltage. Shock or electrocution can result. Always unplug machine before servicing.

INTERNAL COMPONENTS SERVICE

For internal component service, machine is designed to hinge open. Make sure the tanks are empty before opening. Follow instructions below:

- Remove two hex-head bolts at front lift handle, using a 9/16" wrench.
 - Hinge tank backwards away from chassis (*Figure 8*).
-



FIG. 8.

DAILY MAINTENANCE (Every 4 Hour of Operation)

1. Clean machine with a non-abrasive, non-solvent cleaner.
2. Rinse-out tanks and recovery dome thoroughly.
3. Remove any lint buildup from float shut-off screen located in recovery tank. (Figure 9)



FIG. 9.

4. Remove and rinse bladder tank screen.
5. Check power cord for damage – replace if necessary. Coil cord neatly after each use.

WEEKLY MAINTENANCE (Every 20 Hours of Operation)

1. Flush pump system with an acetic acid solution to dissolve normal alkaline chemical buildup.

FOR SAFETY: When using machine, follow mixing and handling instructions on chemical containers.

- a. Mix 473 ml (16 oz) of an acetic acid solution in clean water bladder with 7.5 L (2 gal) of hot water, 60°C (140°F) maximum.
- b. Spray solution into a bucket .

- c. Turn on switch.
 - d. Press trigger on tool until acetic acid solution begins to spray through tips.
 - e. Allow solution to remain in system for up to 6 hours in above freezing temperatures.
 - f. Later, spray out solution into a bucket. Then run 11 L (3 gal) of clean water through system to flush out impurities.
2. Inspect vacuum hose for holes and loose cuffs.
 3. Inspect power cord grip for damage. Replace if damaged.

MONTHLY MAINTENANCE (Every 80 Hours of Operation)

1. Lubricate wheels and casters with water resistant oil.
2. Inspect machine for water leaks.
3. Inspect machine for loose screws.

EVERY 250 OF HOURS OF OPERATION

Check vacuum motor for carbon brush wear. Replace brushes when worn to a length of 10 mm (0.38 in) or less.

STORING MACHINE

1. Before storing machine, be certain to flush tanks and drain machine of all water.
2. Store machine in a dry area in the upright position.
3. Remove recovery dome to promote air circulation.

ATTENTION: Do not expose to rain. Store indoors.

ATTENTION: Do not allow machine to freeze with water in pump system, damage may occur. Damage due to freezing temperatures is not covered by warranty.

STORING MACHINE IN FREEZING TEMPERATURES

1. Drain tanks thoroughly.
2. Pour 1 L (32 oz) undiluted antifreeze into solution bladder.
3. Place a bucket under spray jets to catch spray.
4. Turn on machine.
5. Squeeze trigger on tool for 30 seconds.
6. Allow antifreeze to remain in system.

OPERATION

TROUBLE SHOOTING

PROBLEM	CAUSE	SOLUTION
No power.	Faulty ON/OFF switch	Contact Service Center.
	Faulty wiring.	Contact Service Center.
	Faulty power cord.	Replace power cord.
Solution pump will not operate.	Pump overheated.	Determine cause and let pump cool for 20 minutes.
	Faulty switch.	Contact Service Center.
	Loose or broken wiring.	Contact Service Center.
	Faulty solution pump.	Contact Service Center.
	Faulty ON/OFF switch.	Contact Service Center.
Poor or no vacuum suction.	Vacuum thermal overload tripped.	Check air flow for obstruction, wait 20 minutes for motor to cool.
	Faulty ON/OFF switch.	Contact Service Center.
	Drain hose cap open or loose.	Cap drain hose securely.
	Lint clogging ball float screen.	Remove recovery dome and clean lint off screen.
	Air leakage around dome.	Tighten recovery dome knobs.
	Vacuum hose connections are loose.	Secure connections.
	Damaged vacuum hose or cuffs are loose.	Replace hose or secure cuffs to hose.
	Defective vacuum motor.	Contact Service Center.
Worn carbon brushes.	Replace brushes or call for service.	
Uneven or no spray from tool.	Dirty or plugged spray tips.	Clean or replace tips.
	Improper spray tip size or spray angle.	Replace with proper tips.
	Worn spray tips.	Replace spray tips.
	Loose or broken wiring.	Contact Service Center.
Leaking floor tool.	Quick coupler on floor tool faulty.	Replace quick coupler.
	Flow control valve leaking.	Install valve rebuild kit or contact Service Center.
	Hose split or fittings loose.	Replace hose and tighten fittings.
	Quick coupler and plug not fully engaged.	Reconnect quick coupler.
	Valve stem worn.	Replace or contact Service Center.

SPECIFICATIONS

Model	1100
LENGTH	1070 mm (42 in)
WIDTH	330 mm (13 in)
HEIGHT	860 mm (34 in)
MACHINE WEIGHT	36Kg (80lbs)
SOLUTION BLADDER – RECOVERY TANK CAPACITY	38 ltr (10 gal) – 55 ltr (14.5 gal)
SOLUTION PUMP	120 volt, 100 psi, 1 amp
SOLUTION FLOW RATE	Floor Tool/3 tips = 3.8 ltr (1 gal) per minute 127 mm (5 in) Hand Tool/1 tip = 1 ltr (32oz) per minute
VACUUM MOTOR	120 volt, 3–stage, 1.66 hp, 13 amp, 1560 watts
SEALED WATER LIFT	3.5m (137 in)
DECIBEL RATING AT OPERATOR'S EAR, INDOORS ON CARPET	80dB(A)

RECOVERY/SOLUTION TANK GROUP

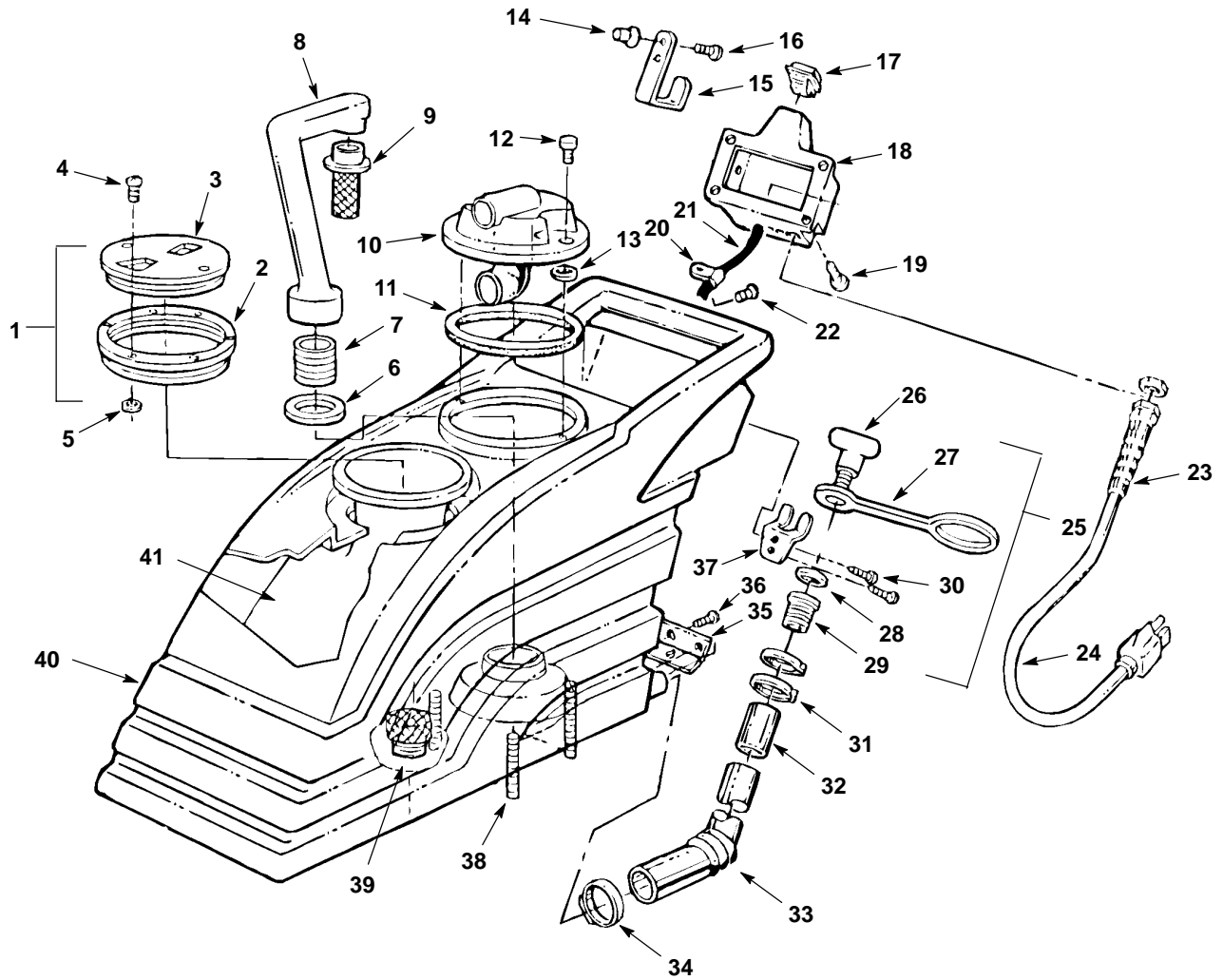

RECOVERY/SOLUTION TANK GROUP

Ref.	Part No.	Description	Qty.
∇1.	100103	ASM., LID, ASSEMBLY	1
▲2.	100109	LID, OUTER RING	1
▲3.	100105	LID, CENTER	1
4.	140900	SCREW, 10-24 X 3/4	6
5.	140000	WASHER, FLAT	6
6.	101714	GASKET, AIR CHAMBER	1
7.	230187	NIPPLE	1
8.	602448	STANDPIPE	1
9.	180613	FLOAT, SHUT-OFF	1
∇10.	700684	ASM., DOME	1
▲11.	100042	GASKET, RECOVERY DOME	1
▲12.	240217	KNOB, RECOVERY DOME	2
▲13.	140037	WASHER, NYL	2
14.	140637	NUT, WELL 10-32	2
15.	230755.BK	BRACKET, CORD	1
16.	140877	SCREW, 10-32X1-1/4	2
17.	602669	SWITCH (120V)	1
18.	607728	SWITCHBOX, (1100)	1
19.	140885	SCREW, 1/4-20 X 1/2	4
20.	140328	CLAMP, NYLON	2
21.	130249	CORD, 14/4X48"	1
22.	140900	SCREW, 10-24X3/4	2
23.	130166	CORD GRIP (120V)	1
24.	130227	CORD, 16/3 X 18" (120V)	2
∇25.	701061	ASM, DRAIN HOSE STOPPER	1
▲26.	230831	KNOB, DRAIN HOSE	1
▲27.	230882	STRAP, RUBBER	1
▲28.	140056	WASHER	1
▲29.	140955	PLUG	1
30.	140826	SCREW, #6 X 3/4	2
31.	140072	CLAMP, EAR 1-9/16"	2
32.	140921	SLEEVE, DRAIN HOSE	1
33.	160416	HOSE, DRAIN	1
34.	140307	CLAMP, HOSE	1
35.	230390	HINGE, TANK	1
36.	140885	SCREW, 1/4-20X1/2	1
37.	230696.BK	BRACKET, DRAIN HOSE	1
38.	140227	STUD	3
39.	180628	SCREEN, TANK	1
40.	607725	TANK, RECOVERY, TEAL	1
41.	602715	BLADDER, SOLUTION	1

DECAL LIST

Ref.	Part No.	Description	Qty.
N/S	608130	DECAL, SIDE "1100"	2
N/S	120619	DECAL, WARNING, EXTRACTORS	1
N/S	120906	DECAL, IMPORTANT-DRAIN	1
N/S	120907	DECAL, IMPORTANT-ALWAYS CLOSE	1
N/S	120399	DECAL, DO NOT ALLOW FOAM	1
N/S	120210	DECAL, TENNANT LOGO	1

PARTS LIST

MAIN CHASSIS GROUP

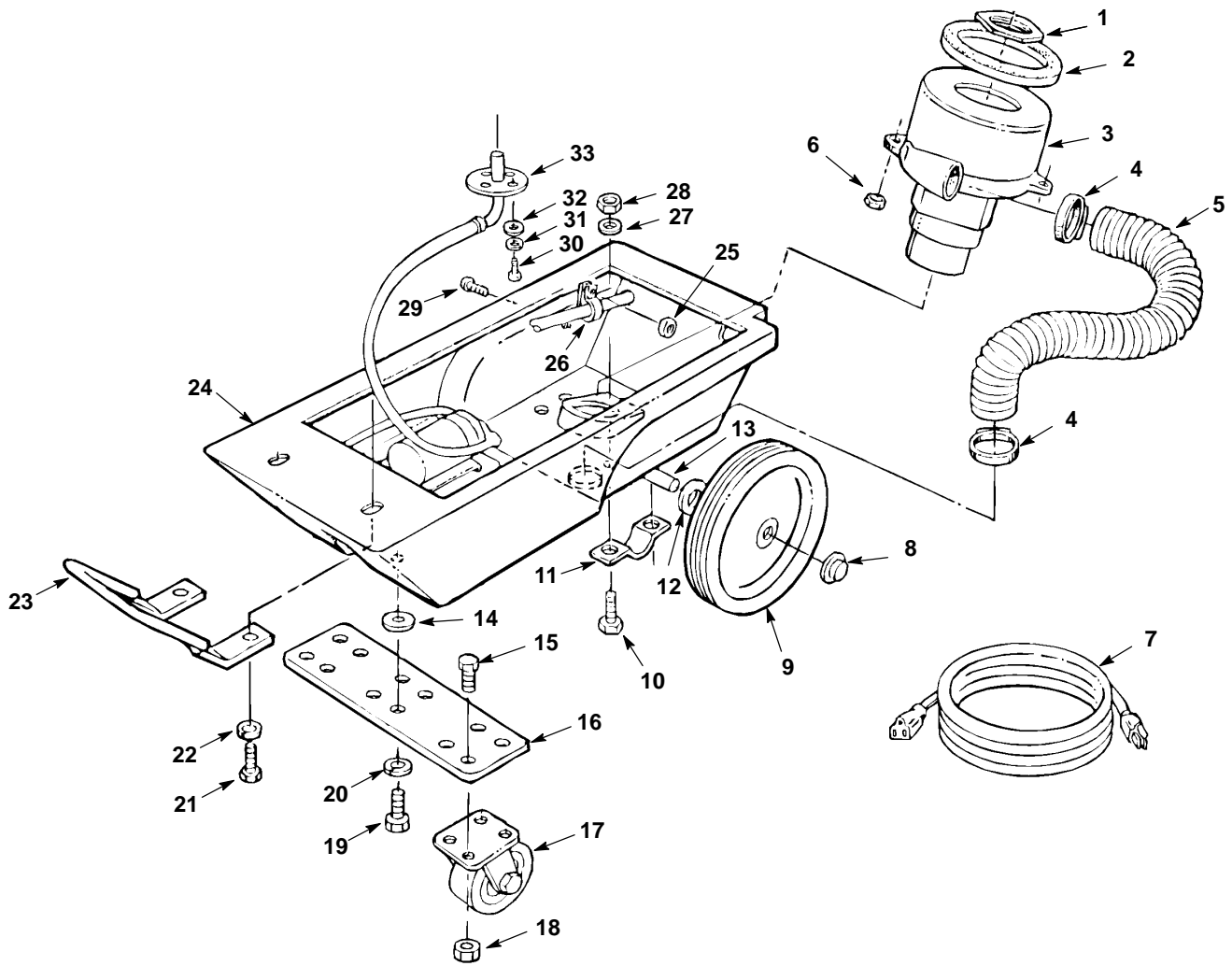

MAIN CHASSIS GROUP			
Ref.	Part No.	Description	Qty.
1.	210240	NUT	1
2.	100118	GASKET, VAC MOTOR	1
3.	130996	MOTOR, VAC 5.7/3 STAGE (120V)	1
	602741	CARBON BRUSHES (2/PK)	2
4.	140308	CLAMP, HOSE	2
5.	160441	HOSE, EXHAUST	2FT
6.	140501	NUT, LOCK	3
7.	130694	CORD	1
8.	103019	CAP, HUB	2
9.	103059	WHEEL	2
10.	140259	SCREW, 1/4-20X5/8	4
11.	230746	BRACKET, AXLE	2
12.	140008	WASHER, FLAT	2
13.	230739	AXLE	1
14.	25732	WASHER, FLAT	4
15.	140226	SCREW, 5/16-18X5/8	8
16.	231034	PLATE	1
17.	103004	CASTER	2
18.	140546	NUT	8
19.	140223	SCREW, 5/16-18X3/4	4
20.	140015	WASHER, LOCK	4
21.	140232	SCREW, 3/8-16X1/4	2
22.	140017	WASHER, LOCK	2
23.	231026.BK	BRACKET, HANDLE	1
24.	607723	CHASSIS, TEAL	1
25.	140552	NUT	1
26.	140916	CLAMP	1
27.	140000	WASHER, FLAT	4
28.	140501	NUT	4
29.	140900	SCREW, 10-24X3/4	1
30.	140889	SCREW, 1/4-20X3/4	4
31.	140016	WASHER, LOCK	4
32.	140000	WASHER, FLAT	4
33.	600451	PLATE, BLADDER	1

PARTS LIST

PUMP SYSTEM GROUP

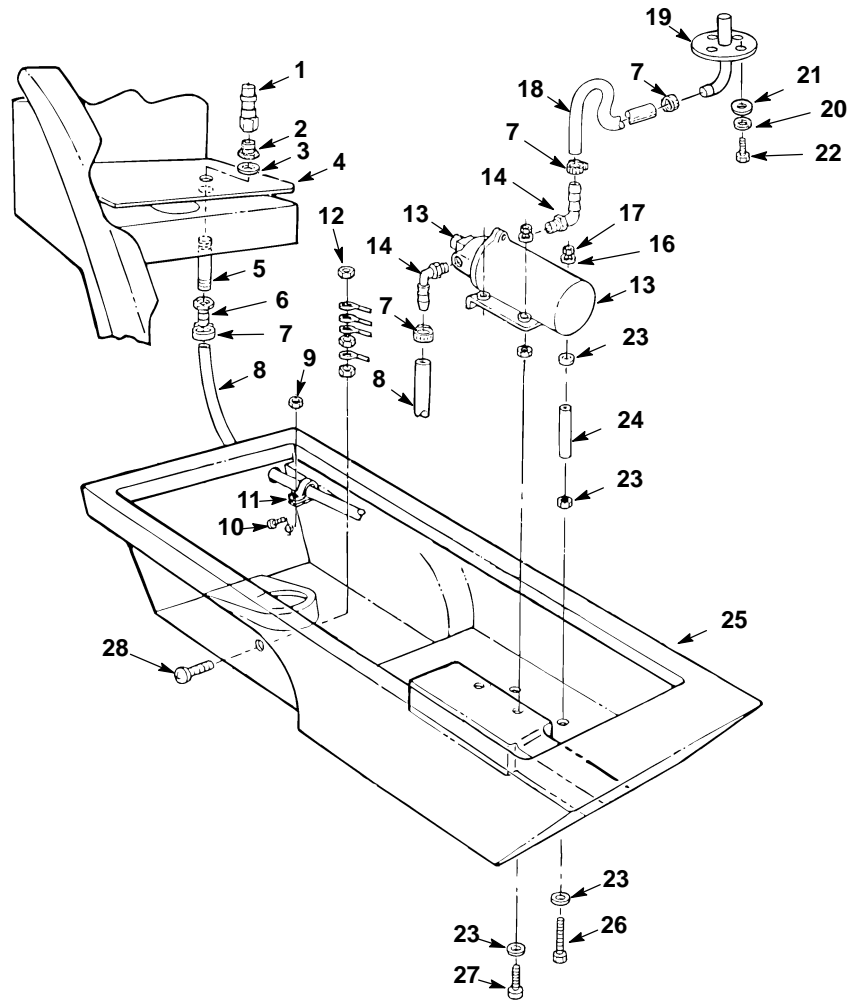

Ref.	Part No.	Description	Qty.
1.	150933	PLUG, QCK COUP – SER 60	1
2.	150000	ADAPTER, 1/4F X 1/4M	1
3.	140008	WASHER, FLAT, 1/2	1
4.	230489	PLATE	1
5.	150600	NIPPLE	1
6.	150511	HOSE BARB, 1/4FX3/8H	1
7.	140305	CLAMP	4
8.	160207	HOSE, 3/8 LP	3.3FT
9.	140552	NUT, LOCK NYL.	1
10.	140891	SCREW, 10-24X5/8	1
11.	140323	CLAMP, NYLON	1
12.	140519	NUT, KEP 10 – 24	3
13.	180103	PUMP, 100 PSI – 120V	1
14.	150425	ELBOW, 3/8M X 1/2H 90°	2
15.	140519	NUT, KEP 10-24	2
16.	140012	WASHER, FLAT 3/16"	8
17.	140519	NUT, KEP 10-24	4
18.	160207	HOSE, 3/8 LP GRAY	2.5FT
19.	600451	PLATE, BLADDER	1
20.	140016	WASHER, LOCK 1/4"	4
21.	140000	WASHER, FLAT	4
22.	140889	SCREW, MCH 1/4-20X3/4	4
23.	140011	WASHER, FLAT 3/16	10
24.	140917	SPACER, NYLON	2
25.	607723	CHASSIS, TEAL	1
26.	140354	SCREW, 10-24X3"	2
27.	140899	SCREW, 10-24X1-1/4	2
28.	6032.6	SCREW	4

PUMP BREAKDOWN

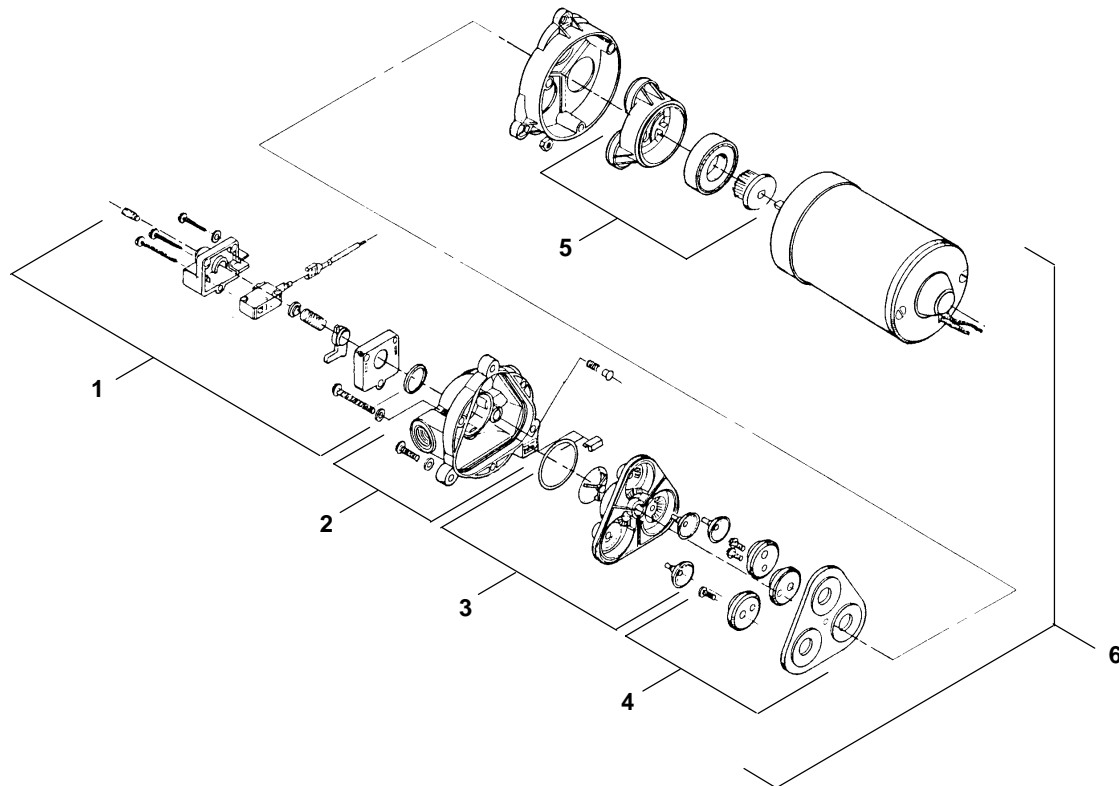

Ref.	Part No.	Description	Qty.
1.	190129	KIT, PRESSURE SWITCH	1
1.	190172	KIT, PRESSURE SWITCH (VITON)	1
	190134	KIT, DIAPHRAGM ONLY	1
2.	190128	KIT, UPPER PUMP HOUSING	1
	190124	KIT, CHECK VALVE ONLY	1
3.	190171	KIT, VALVE (VITON)	1
4.	190131	KIT, SERVICE	1
5.	190130	KIT, LOWER PUMP HOUSING	1
6.	180103	PUMP, 100 PSI	1

WIRE DIAGRAM

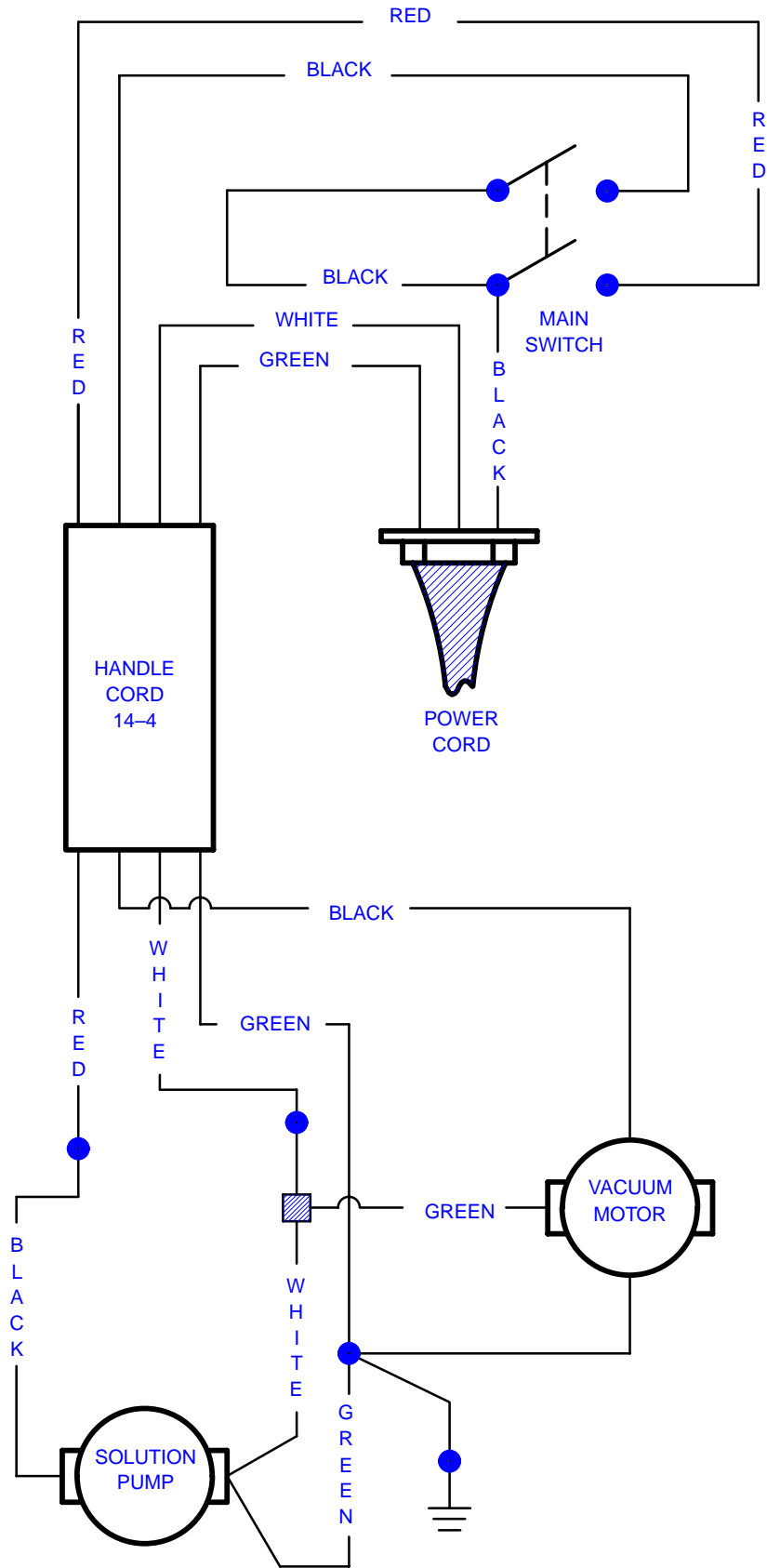

127 mm (5 in) HAND TOOL

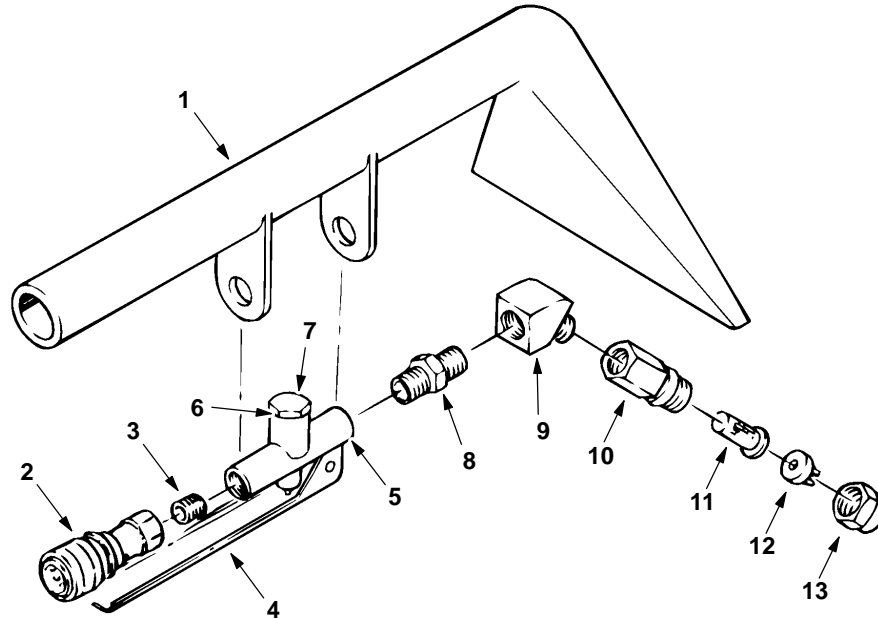

Ref.	Part No.	Description	Qty.
1.	200505	TOOL, HAND (COMPLETE)	1
	200431.BK	TOOL, HAND	1
2.	150913	COUPLER, QUICK (SER. 60)	1
3.	150615	NIPPLE, CLOSE	1
4.	200905	TRIGGER, HAND TOOL	1
5.	210210	VALVE, FLOW CONTROL	1
6.	190600	VALVE PIN & SPRING (NOT SHOWN)	1
7.	N/A	CAP, VALVE	1
8.	150606	NIPPLE, HEX 1/4	1
9.	150403	ELBOW, ST 1/4 45°	1
10.	200992	BODY, SPRAY 1/4F	1
11.	200996	SCREEN, SPRAY NOZZLE	1
12.	200965	TIP, SPRAY #8002	1
13.	200994	CAP, SPRAY BODY	1

SOLUTION AND VACUUM HOSES

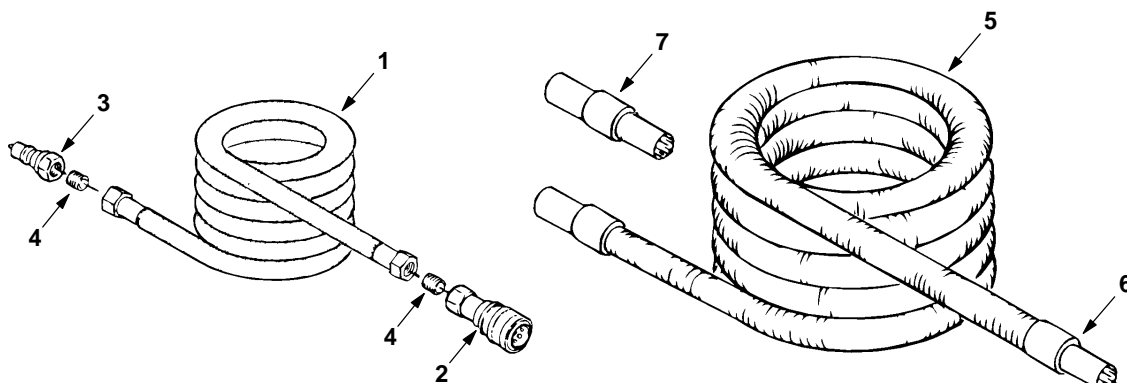

Ref.	Part No.	Description	Qty.
1.	160185	HOSE, SOLUTION 15'	1
1.	160186	HOSE, SOLUTION 25'	1
2.	150913	COUPLER, QUICK SER. 60	1
3.	150933	PLUG, QUICK COUPLER	1
4.	150615	NIPPLE	2
5.	160400	HOSE, VACUUM 15' W/ CUFFS	1
5.	160401	HOSE, VACUUM 25' W/ CUFFS	1
6.	160430	CUFF, HOSE 1-1/2"	2
7.	160451	CONNECTOR, VACUUM HOSE 1-1/2"	1

OPTIONAL PARTS

FLOOR TOOL

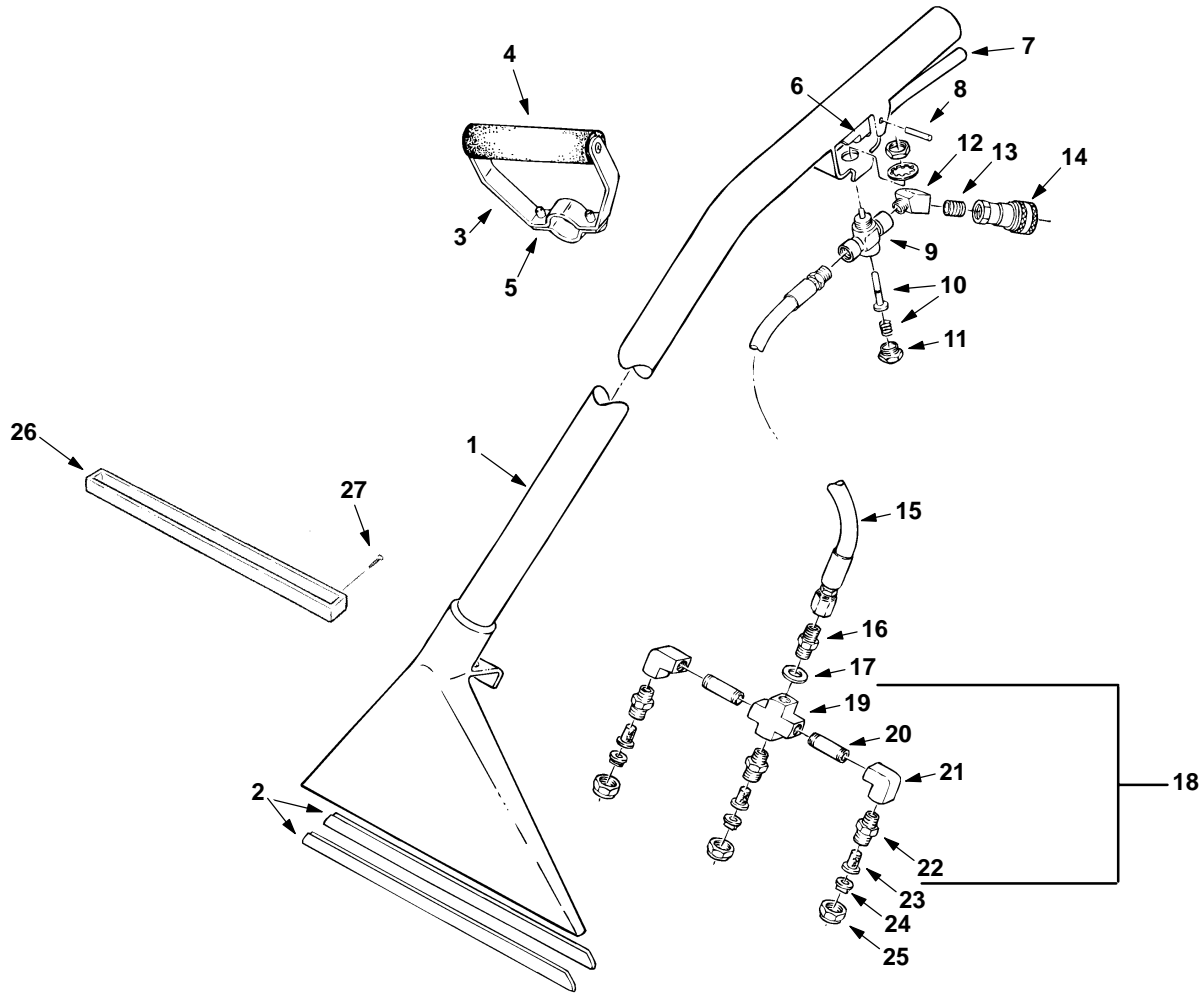

Ref.	Part No.	Description	Qty.
	600048	FLOOR TOOL W/ S.S. SHOES (COMPLETE)	1
1.	200403.BK	TOOL, FLOOR	1
2.	200939	SHOES, S/S, FLOOR TOOL	2
3.	200927	GRIP, ADJUSTABLE (COMPLETE)	1
4.	200912	FOAM, GRIP	1
5.	140259	SCREW, 1/4X3/4	2
6.	200902	TRIGGER, FLOOR TOOL	1
7.	200809	SLEEVE, TRIGGER	1
8.	140605	PIN	1
	1405202-970	NUT, PUSH (NOT SHOWN)	2
9.	210150	VALVE, FLOW CONTROL	1
10.	190603	KIT, VALVE PIN & SPRING	1
11.	N/A	CAP, HEX, VALVE	1
12.	150403	ELBOW, 1/4-45°	1
13.	150615	NIPPLE, CLOSE 1/4	1
14.	150913	COUPLER, QUICK SER. 60	1
15.	160170	HOSE, SOLUTION, LP	1
16.	150606	NIPPLE, HEX 1/4"	1
17.	140058	WASHER	1
▽18.	700062	ASM., SPRAY BAR	1
▲19.	150700	CROSS	1
▲20.	150600	NIPPLE	2
▲21.	150401	ELBOW, 90° 1/4FX1/4F	2
▲22.	200993	SPRAY BODY	3
▲23.	200996	SCREEN, SPRAY BODY	3
24.	200964	TIP	3
25.	200994	CAP, SPRAY BODY	3
26.	N/A	PLATE, GLIDE	3
27.	N/A	END FASTENERS	3