

240X Floor Scrubber Battery

Model:
MC240024QP, CE

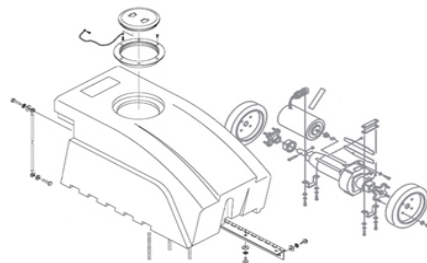

FLOOREQUIPMENTPARTS.COM

OPERATION

SERVICE

PARTS

CARE

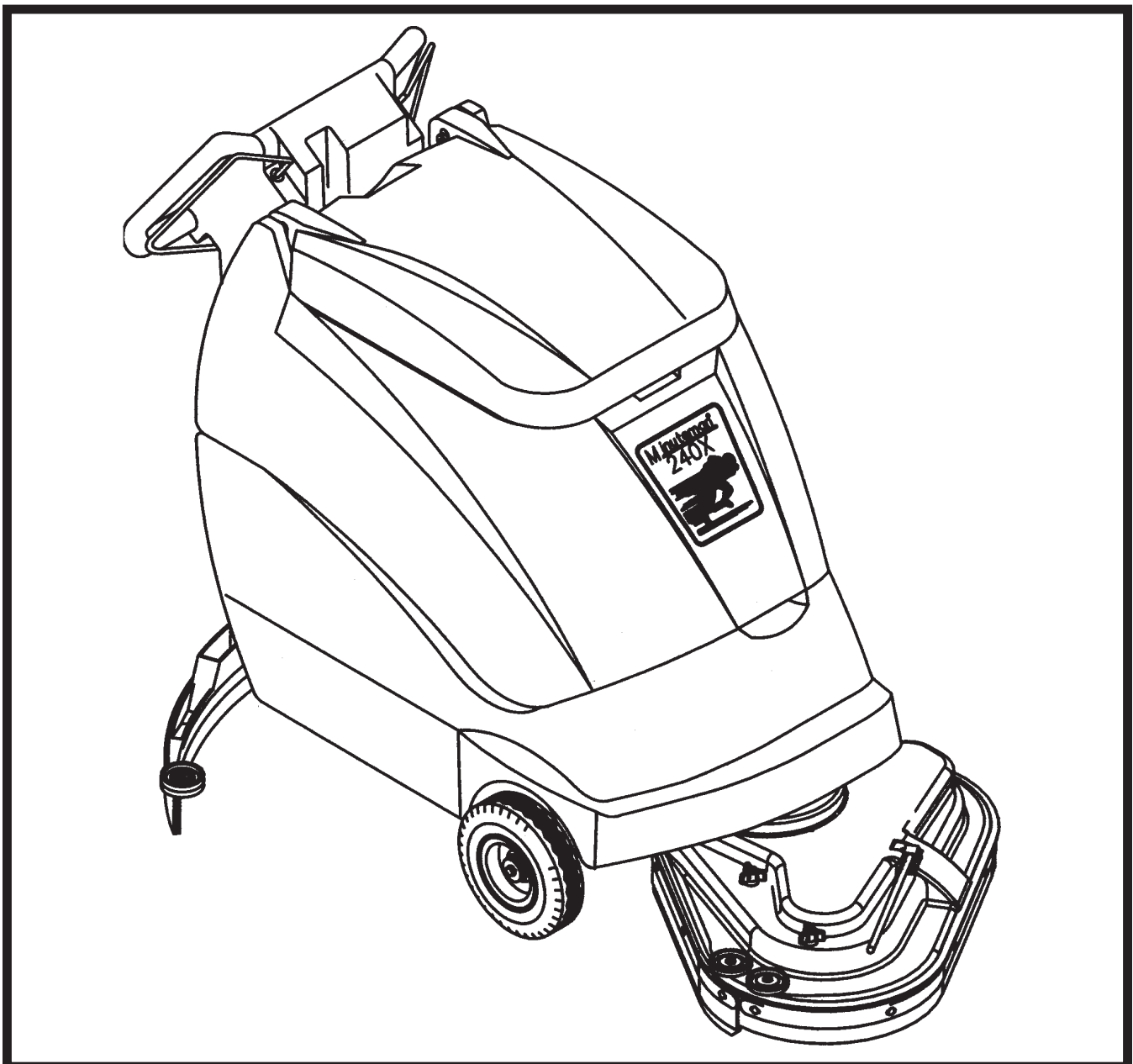

Revised 8/02

Minuteman[®]

EC Declaration of Conformity

according to Directives 72/23, 89/392, and 89/336

We, Minuteman International Incorporated, of 111 South Rohlwing Road Addison Illinois 60101 USA, declare under our sole responsibility that the product MC20004CE Commercial Automatic Floor Scrubber to which this declaration relates corresponds to the relevant requirements of the EC Directives 72/23, 89/392 and 89/336. The following standards were used to determine compliance with the Directives: EN 292, EN 294, EN 811, EN 55014, EN 55104 and IEC 335-1-72.

SOUND		VIBRATION									
81 dB Operator	77dB At 3m	4.8 m/s² At Operators Handle									
<p>Tests were conducted on 6/14/00 with calibrated sound and vibration equipment under the conditions noted below:</p> <table style="width: 100%; border: none;"> <tr> <td style="width: 33%;">General Condition: Indoors</td> <td style="width: 33%;">Wind: 0 km/hr</td> <td style="width: 33%;"></td> </tr> <tr> <td>Temperature: 23^oC</td> <td>Humidity: 70%</td> <td></td> </tr> <tr> <td>Barometric Pressure: 29.1</td> <td></td> <td></td> </tr> </table>			General Condition: Indoors	Wind: 0 km/hr		Temperature: 23 ^o C	Humidity: 70%		Barometric Pressure: 29.1		
General Condition: Indoors	Wind: 0 km/hr										
Temperature: 23 ^o C	Humidity: 70%										
Barometric Pressure: 29.1											



Jeff Pollack, Standards Engineer

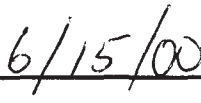

Date

Table of Contents

Safety instructions	1
Electrical requirements	2
Control panel identification.....	3
Operating instructions	4
Squeegee adjustments.....	5
Brush installation/removal	6
Base assembly	7 - 8
Tank assembly	9 - 10
Upper assembly	11
Console assembly	12
Motor lift assembly	13 - 14
Scrudhead assembly	15 - 16
Casting assembly	17
Motor assembly	18
Dashboard & back panel assembly	19
Squeegee lift & Squeegee mechanism	20
Plastic housing assembly	21
Squeegee assembly.....	22
Wiring diagram, standard	23 - 24
Wiring diagram, CE	24 - 25
Warranty	Back Cover

IMPORTANT SAFETY INSTRUCTIONS

CAUTION

Operators must read and understand this manual before operating or maintaining this equipment.

- Keep hands and feet clear of moving parts while machine is in operation.
- All switches must be in the “OFF” position when charging batteries.
- Electrical motors and components can cause an explosion when operated near explosive materials or vapors. Do not operate this machine near flammable materials such as solvents, thinners, fuels, grain dusts, etc.
- Make sure all switches are turned “OFF” and battery connections are removed before performing any maintenance procedures.
- Store or park this machine on a level surface only.
- These machines are designed for level floor operation only. **DO NOT OPERATE** on ramps or inclines.
- Battery acid can cause burns. When working on or around batteries, wear protective clothing and safety glasses. Remove metal jewelry. Do not lay tools or metal objects on top of batteries.
- This machine is not suitable for picking up hazardous dust.

Charging batteries generates explosive gases. **DO NOT CHARGE BATTERIES WHEN OPEN FLAMES OR SPARKS ARE PRESENT. DO NOT SMOKE.** Make sure the charger is turned off before disconnecting it from the batteries. Charge the batteries in a well-ventilated area.

Maintenance and repairs must be performed by authorized personnel.

SAVE THESE INSTRUCTIONS

ELECTRICAL REQUIREMENTS:

This piece of equipment operates on 24 Volt DC.

BATTERY REQUIREMENTS:

2 x 12V 210 Amp Hour 20 Hour Rate Deepcycle P/N 956210

BATTERY SERVICE AND INSTALLATION:

Warning: Battery acid can cause burns. When working on or around batteries, wear protective clothing and safety glasses. Remove metal jewelry. Do not lay tools or metal objects on top of batteries.

BATTERY INSTALLATION:

1. Raise tank assembly by gripping the front of tank and lift tank backward as shown in Fig. 1.
2. Install batteries as shown in Figure 2.

CHARGING OF BATTERIES:

Charging of batteries generates explosive gases. DO NOT CHARGE BATTERIES WHEN OPEN FLAMES OR SPARKS ARE PRESENT. DO NOT SMOKE. Make sure the charger is turned off before disconnecting it from the batteries. Charge the batteries in a well-ventilated area. Fluid levels should be checked before and after charging and maintained at the proper levels.

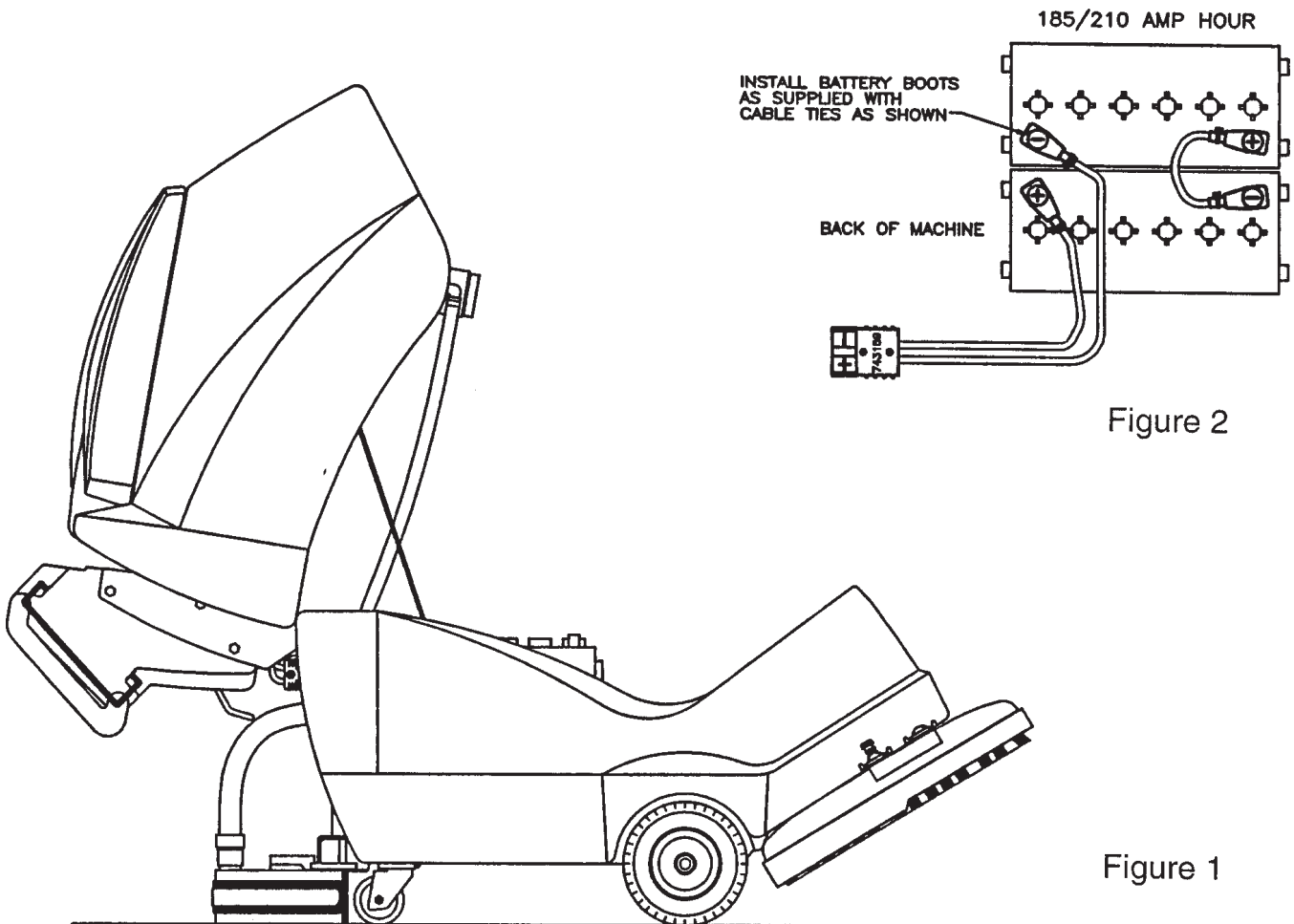

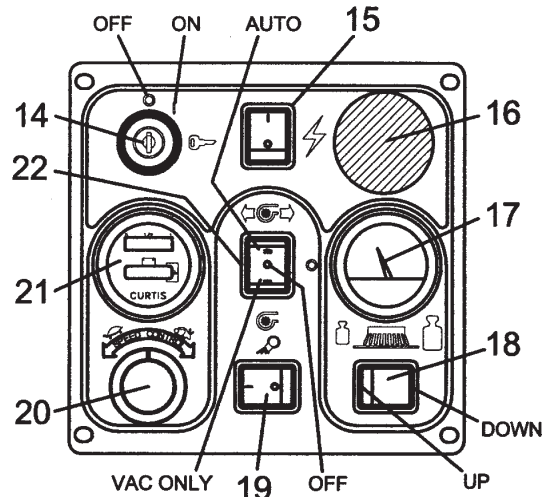
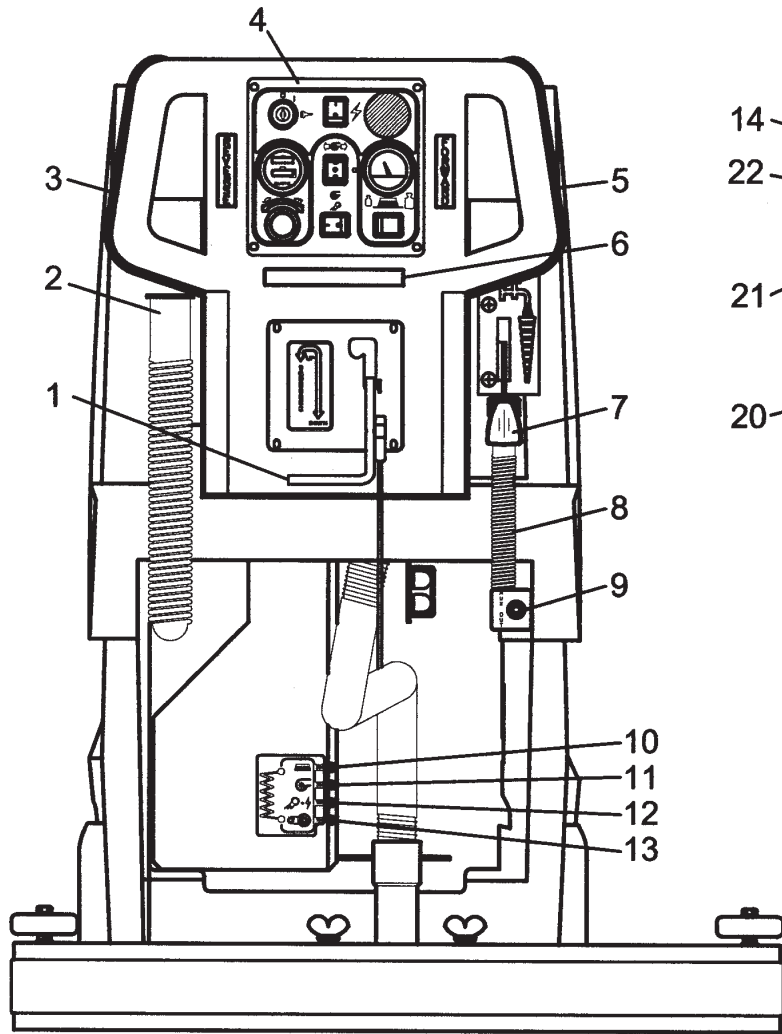

1. Squeegee lift lever
2. Recovery dump hose
3. Reverse handle
4. Dashboard control panel
5. Forward handle
6. Safety bar switch
7. Solution control lever
8. Solution dump hose
9. Quick disconnect - Aux. out (Deluxe only)
10. Circuit breaker - Brush
11. Circuit breaker - Vac
12. Circuit breaker - System
13. Circuit breaker - Transaxle
14. Keyswitch
15. Main power
16. Emergency button
17. Brush pressure gauge
18. Brush control
19. Pump switch
20. Speed control
21. Battery condition meter
22. Vacuum control switch

AUTO SCRUBBER BRUSH DESCRIPTION

TYPE	DESCRIPTION	DURABILITY*	COLOR	COMPARISON TO PADS	RECOMMENDED USE
Bassine	Natural Fiber	Short	Dark Brown	Red	Light duty general cleaning, acid etching
Nylon	Nylon	Medium	Black	Tan/Red	General cleaning & scrubbing vinyl floors, ceramic tile & concrete floors
Dyna-Scrub	Nylon impregnated with 500 Grit Silicon Carbide Fine Bristle, Dense Fill	Long	Light	Red	General scrubbing, vinyl tile, ceramic tile, epoxy floors, urethane finish, uneven concrete floors
Power-Scrub	Nylon impregnated with 120 Grit Silicon Carbide Fine Bristle, Dense Fill	Long	Rust	Red/Blue	Moderate aggressive scrubbing, tile floors, concrete floors
Poly-Grit	Nylon impregnated with 80 Grit Silicon Carbide Coarse Bristle	Long	Green	Brown/Black	Aggressive stripping and scrubbing, tile floors, unfinished concrete floors
Strata-Grit	Nylon impregnated with 46 Grit Silicon Carbide Coarse Bristle	Long	Dark Blue	Black	Heavy duty stripping/scrubbing unfinished concrete

• Durability is dependent on floor surface, chemicals used and proper care.

OPERATING INSTRUCTIONS

BEFORE STARTING, FAMILIARIZE YOURSELF WITH THE MACHINE AND ITS CONTROLS (SEE MACHINE OVERVIEW & CONTROL PANEL DIAGRAMS)

1. Filling: Fill the solution tank with the desired amount of water and add liquid cleaning solution to the proper dilution ratio. DO NOT USE powdered cleaning chemicals. Powders are unlikely to dissolve thoroughly, resulting in clogging the in-line solution filter. This can reduce or stop water flow to the brush.
2. Close lid.
3. Turn on machine by lifting the red emergency disconnect button (17) so it is in the up position. Turn keyswitch (15) clockwise to “on” position and turn on main power switch (16).
4. Adjust main speed control (21) to full counter-clockwise position.
5. Lower brush assembly.
 - To lower the brush, first push the pedal (10) slightly outward on the machine (unlock it), and then release it slowly or by pressing “brush down” switch (19) on Deluxe models.
 - To lift the brush, press the pedal (10) down until lift mechanism engages or by pressing “brush up” switch (19) on Deluxe models.
 - Brush will come on automatically when brush in on the floor and “forward” (5) or “reverse” (3) handles are squeezed and remain on approximately 5 seconds after release.
6. Adjust solution control feed lever.
7. Select vacuum operations:
 - “Vacuum On” mode (23) - Vacuum will remain on until switched to the “off” position
 - “Vacuum Auto” mode (23) - Vacuum will come on automatically when “forward” or “reverse” handle is squeezed, and scrubhead is on the floor. The brush and vacuum will remain on approximately 5 minutes.
8. Lower squeegee assembly by lowering handle (1).
9. Squeeze “forward” handle (5) and adjust forward speed (21) as desired.

After Use:

1. Turn off solution feed.
2. Raise squeegee assembly.
3. Turn off vacuum motor.

Solution and recovery tanks should be emptied after every use.

MAINTENANCE:

- | | |
|---------|--|
| Daily | 1. Clean float assembly & squeegee blades. Vac filter |
| | 2. Recharge batteries (check battery acid levels before and after charging). |
| Monthly | 1. Check wear on squeegee blades. |
| | 2. Grease front wheels. |
| | 3. Grease pivot points on brush motor assembly. |

Every 500 hours check condition of carbon brushes on vacuum motor and brush drive motor.

SQUEEGEE ADJUSTMENTS

Squeegee Adjustment

The squeegee set-up is pre-adjusted at the factory. Adjustments may be required to get optimum performance for different floors and conditions.

Pitch Control Adjustment

1. Ensure that the scrubber is on a relatively flat surface. Pull the red emergency button away from the dashboard to activate power. Turn on the main power switch and turn the key switch clockwise to the on position. Raise the scrubhead off the floor. Turn the vacuum switch to the "vacuum only" position.
2. Turn the speed control knob counter-clockwise to the low speed position. Lower the squeegee (item 1) to the floor and squeeze the forward control handle, move the machine one or two feet forward to check the rear squeegee blade for uniform deflection to the floor.

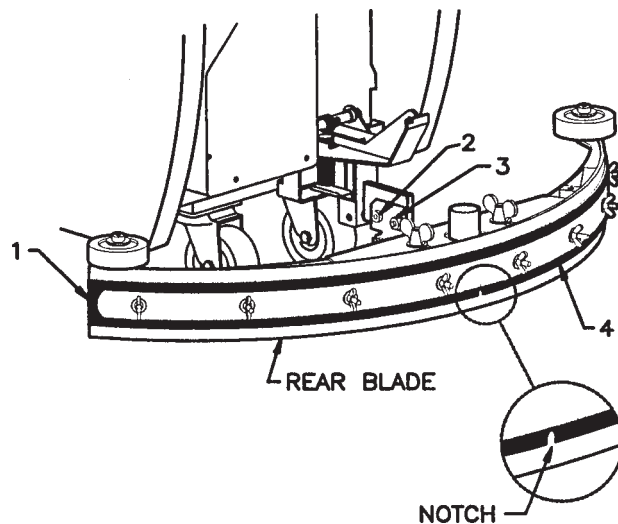

3. If uneven deflection or lay is evident, minor adjustments may be necessary to avoid streaking and uneven wear on the blade.
4. To correct this, pitch adjustment is necessary. Loosen the pivot screw (item 2) and the pitch screw (item 3). Move the machine forward and allow the squeegee to level itself or adjust the angular position accordingly to achieve a uniform blade deflection. Re-tighten screws.
5. In certain applications where a different blade set-up is required, the reinforcement blade (item 4) may be turned upside down. The notch, which is normally on the bottom will now be located on the topside. This allows the rear squeegee blade a larger deflection than normal.

BRUSH INSTALLATION - REMOVAL

INSTALLATION

1. Raise the scrubhead to the "UP" position by pressing the switch "BRUSH UP" (B) switch as shown on Fig. 2 until the scrubhead stops retracting upwards.
2. Hold brush under the scrubhead casting while lining up the center of brush with the hex drive hub and pressing the brush up until the brush engages on the hub.

REMOVAL

1. Raise the scrubhead to the "UP" position by pressing the switch "BRUSH UP" (B) switch as shown on Fig. 2 until the scrubhead stops retracting upwards.
2. Flip the handle up (Fig. 1) located at the middle of the plastic shroud. Push the handle towards the machine and the bracket underneath the casting will release both brushes at once. Replace handle in parked position.

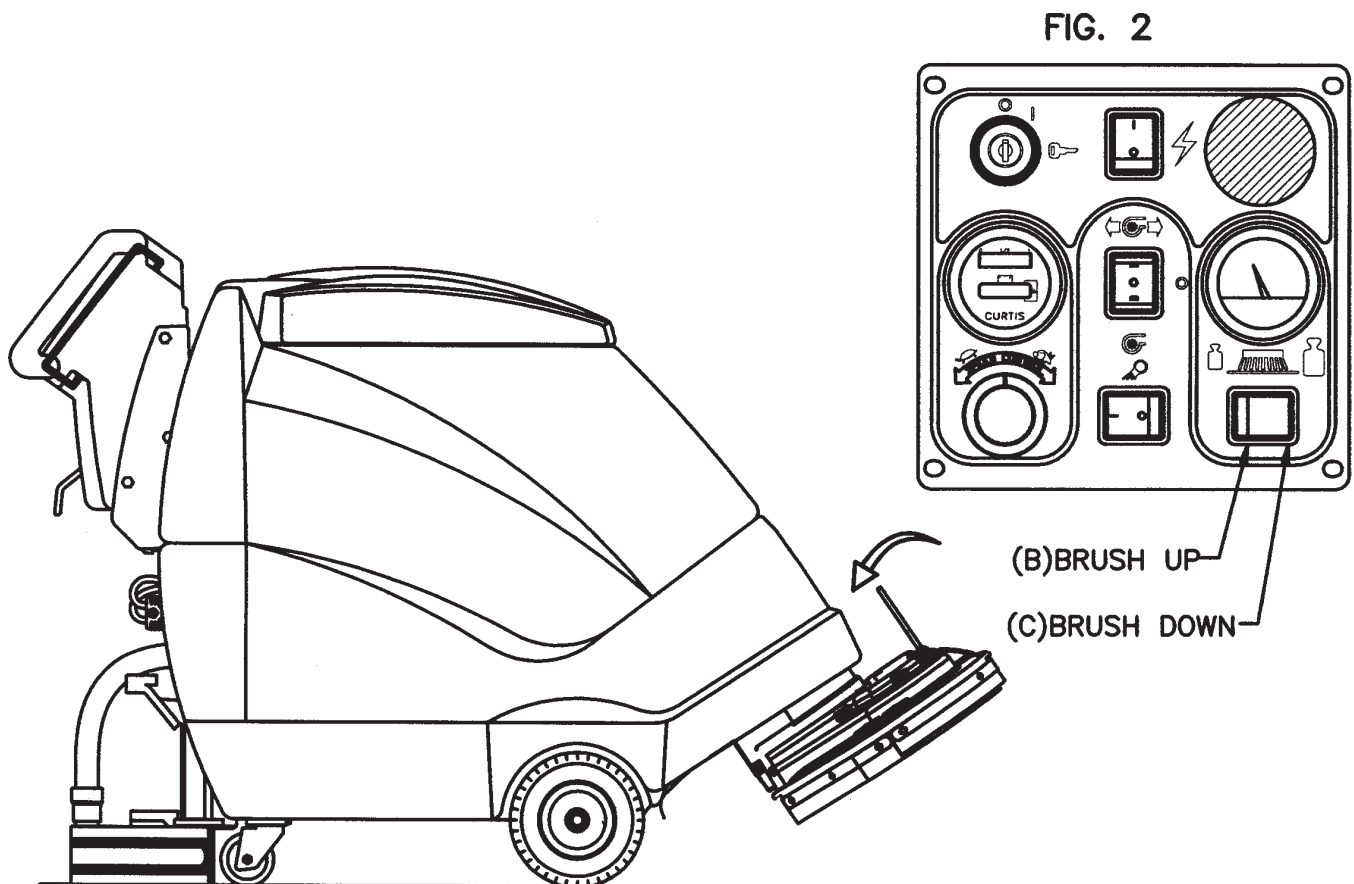
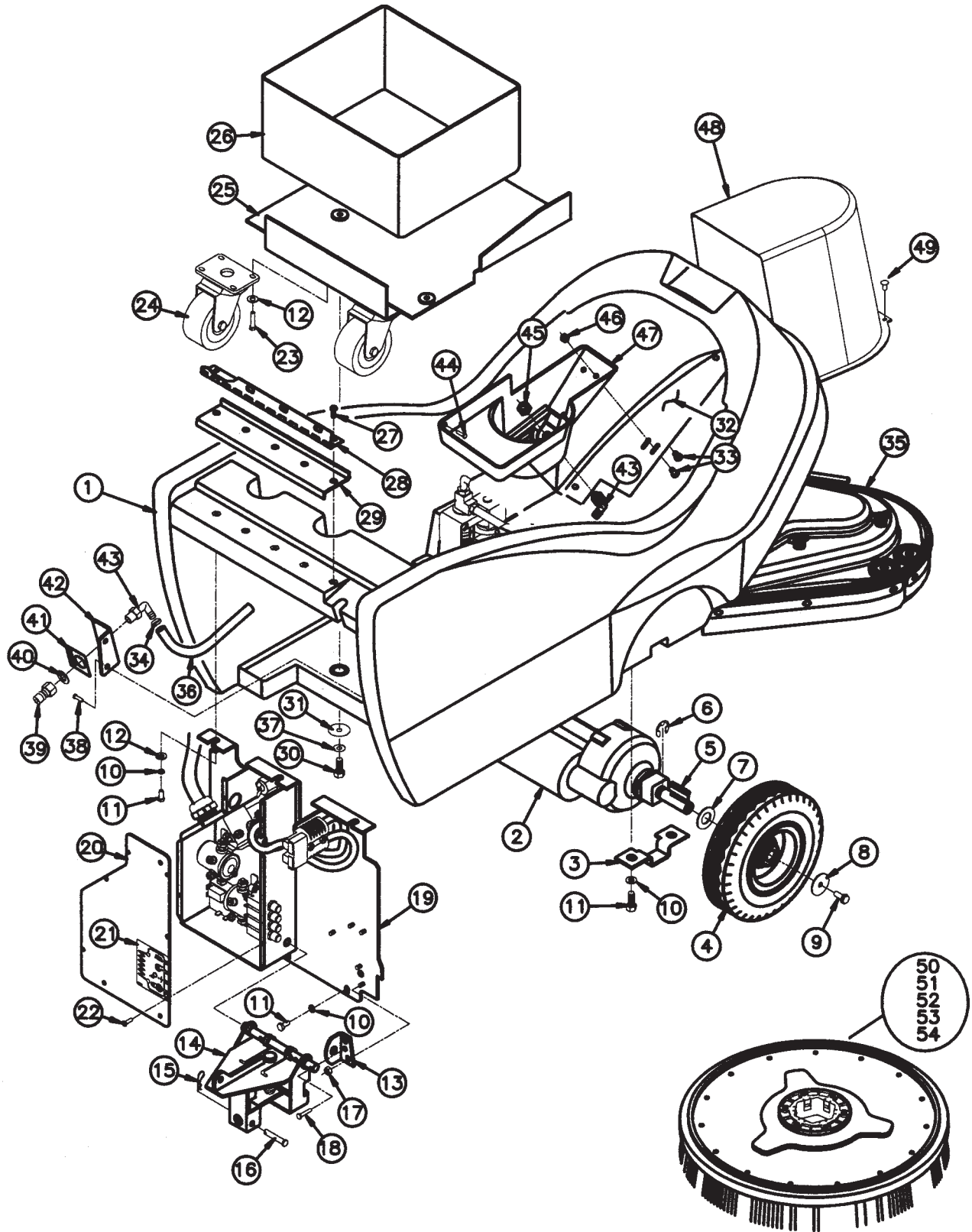

Figure 1

BASE ASSEMBLY



Parts List

Item	Part No.	Qty.	Description
1	200102	1	Base
2	743506	1	Transaxle 24V
3	200126	2	Transaxle Mount
4	200172	2	Tire, Pneumatic
5	361233	2	Key 3/16 sq. x 1.50
6	809148	2	E-Ring 3/4
7	712318	2	WSR-Flat 3/4 x 1.12 x .12
8	712759	2	WSR-Flat 5/16 x 1.37 x .06 SS
9	712042	2	Bolt-WSR HH 5/16-18 x .62
10	711544	30	WSR-Helical 1/4
11	711203	19	BLT-HH 1/4-20 x .62
12	711505	11	WSR-Flat 1/4
13	200158	1	Pin Bracket
14	200153	1	Squeegee Mechanism Assy.
15	711808	1	Cotter Pin
16	210415	1	Clevis Pin 5/16
17	260183	3	Nut 1/4 NPT Nyloc
18	712564	1	Bolt-HH 1/4-20 x 1 SS
19	200175	1	Back Panel Assy.
20	200154	1	Electrical Box Cover
21	715286	1	Decal, CB
22	711125	4	SCR-ST-B #10 x 1/2
23	713002	8	BLT-HH 1/4-20 x .75
24	762333	2	Caster, 3 1/2"
25	200125	1	Battery Tray Weldment
26	210048	1	Battery Liner
27	712565	5	SCR-MC 1/4 - 20 x .62 SS
28	200145	1	Hinge
29	200146	1	Hinge Plate
30	711228	4	Bolt-HH 5/16-18 x 3/4
31	711507	4	WSR-Flat .37 x 1.12 x .06
32	200233	1	Bottom Cover
33	712822	5	SCR-THMS 10-24 x 1/2
34	450076	2	Crimp Clamp 185R SS
35	200500	1	Scrubhead Asm 240X
36	200236	1	Auxilliary Hose 48.50
37	711545	4	WSR-Helical 5/16
38	711161	1	Hi/Lo Screw #10 x 3/4
39	828368	1	Male Coupler BH2-61
40	711594	1	WSR-Flat .56 x .88 x .03
41	715144	1	Decal Aux Pump
42	200237	1	Quick Disconnect Bracket
43	833325	2	Barb 90° Elbow 3/8 x 1/4 NPT
44	711160	1	Hi/Lo Screw #10 x 5/8
45	260183	1	Nut-Nylon 1/4 NPT
46	712908	2	Nut-Wizz 10-24
47	200318MCH	1	Reservoir
48	200523	1	240X Motor Cover
49	710178	2	SCR-MC 1/4-20 x .50 Truss
50	260002-1	2	Pad Driver, No Riser
51	260003	2	Bassine Brush
52	260004	2	Nylon Brush
53	260005	2	Poly-Grit Brush
54	260006	2	Strata-Grit Brush

BASE ASSEMBLY

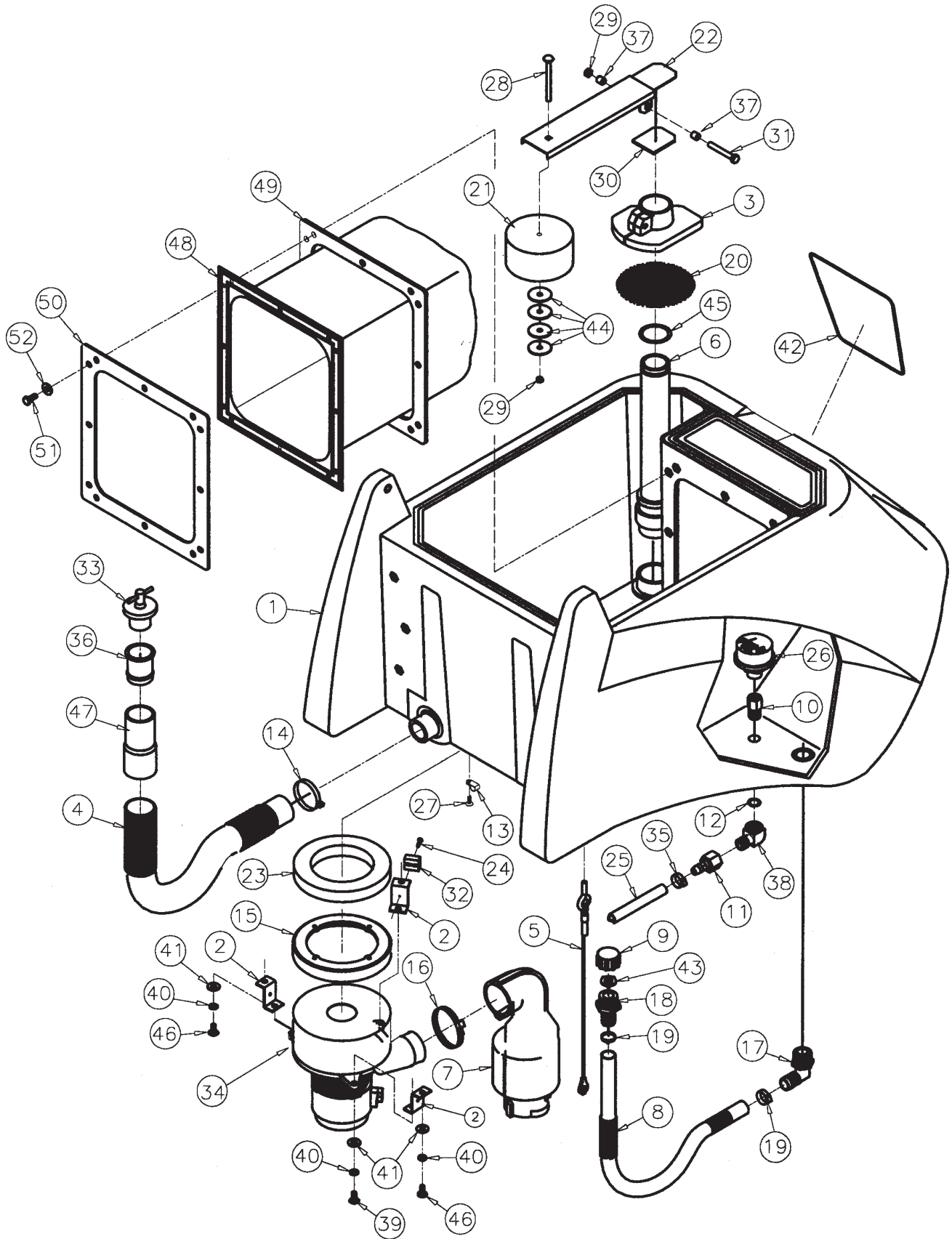

Parts List

Item	Part No.	Qty.	Description
1	200102MCH	1	Sol/Rec Tank
2	200147	3	Bracket, Vac Motor
3	200173	1	Float, Housing
4	210122	1	Drain Hose, Wirelock
5	200232	1	Cable, Tank
6	200251	1	Stand Pipe Assembly
7	200258	1	Muffler Assembly
8	200270	1	Hose, 3/4 Solution Drain
9	200023	1	Garden Hose Cap
10	210409	1	Fitting, Brass 3/8MPT
11	210410	1	Fitting, Brass 3/8FPT
12	210414	1	"O" Ring 2-113
13	250039	3	Clamp, Plastic 5/16 3305
14	260203	1	Hose Clamp, 102120 Murray
15	290017	1	Gasket, Molded, Vac Motor
16	760859	1	Clamp-Hose
17	383321	1	Elbow 3/4MPT 3/4BARB PP
18	200022	1	3/4" MGHT x Hose Barb
19	829129	2	Clamp, Crimp 3/4 Hose
20	430050	1	Filter Screen 4x4
21	260155	1	Foam Float
22	200320	1	Shut Off Weldment
23	460019	1	Gasket
24	710207	1	SCR-MC 6-32 x .87 ST PL
25	200234	REF	Solution Hose
26	130118	1	Solution Strainer
27	712540	3	SCR-MC #10-24 x .375 SS
28	712574	1	CR Bolt SS 1/4-20 x 3"
29	712667	2	Nut-Hex 1/4-20 SS Nyloc
30	200321	1	Gasket, Shut Off
31	712568	1	SCR-MC 1/4-20 x 2.25 SS
32	832996	1	Terminal Black 2 Pole VDE
33	833316	1	Drain Plug
34	740225	1	Vac Motor 6515-13 24V
35	760245	2	Hose Clamp 62P24
36	760343	1	Tube Hose 24/32B
37	762384	2	Bushing .277 x .375 x .37 SS
38	830062	1	Fitting Brass 90 3/8MPT
39	710180	3	SCR-MC 1/4-20 x .75
40	711544	6	Lockwasher-Helical 1/4
41	711505	6	Washer 1/4
42	715295	1	Decal, 240X
43	200024	1	Black Vinyl Washer
44	712759	4	WSR-Flat .31 x 1.37 x .06 SS
45	310008	1	O-Ring
46	712565	3	SCR-MC 1/4-20 x .625 SS
47	805613	1	Hose Cuff, Grey Vinyl
48	200106	1	Bladder Bag
49	200267	1	Gasket, Bladder
50	200189	1	Frame, Bladder
51	712562	12	SCR-MC HH 1/4-20 x .75 SS
52	711504	12	Washer 1/4 SS

UPPER ASSEMBLY

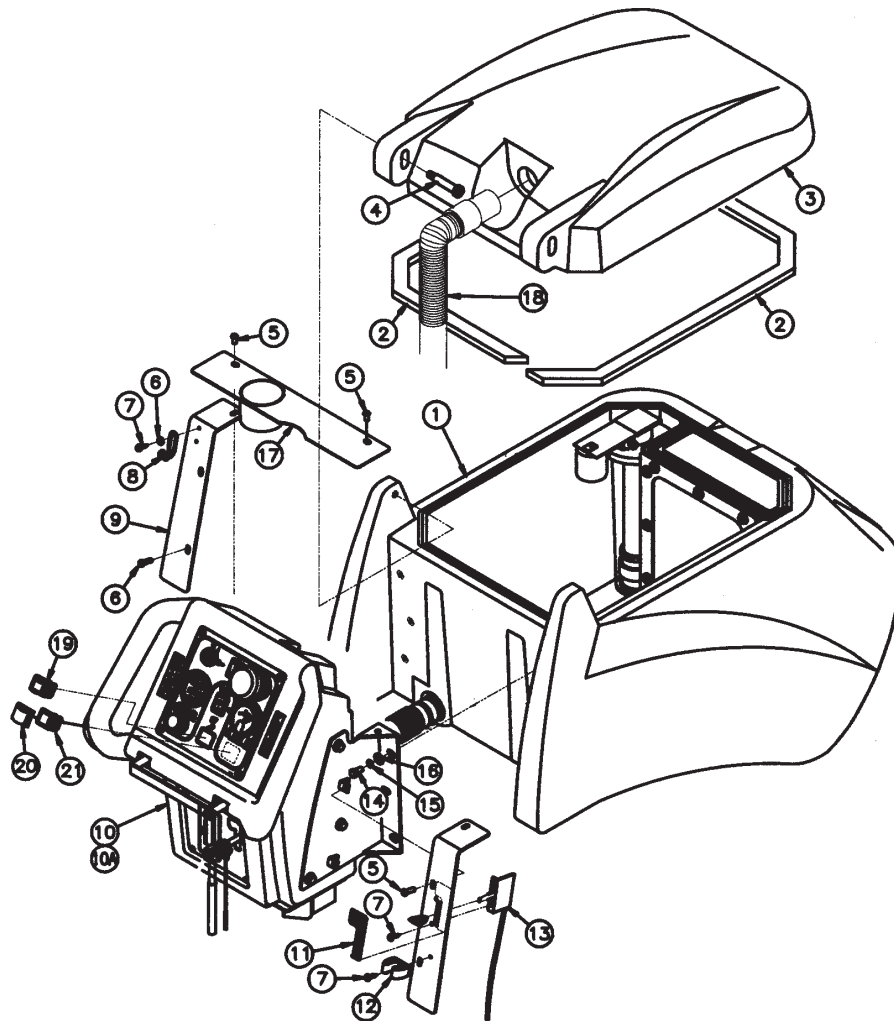

Parts List

Item	Part No.	Qty.	Description
1	200275	1	Tank Assy. - Deluxe
2	200178	2	Gasket, Lid
3	200103	1	Tank Lid
4	712120	2	Shoulder Bolt 1/2 x 2
5	710178	6	SCR-MC 1/4-20 x 1/2
6	711503	2	WSR-Flat #10
7	711125	5	SCR-ST-B #10 x 1/2
8	760286	1	Wire Formed Hook
9	200176	1	Dump Hose Bracket
10	200180	1	Console Assy. TD/Deluxe
11	200170	1	Console Assy. - Brush Drive
11A	715284	1	Decal, Solution Control
12	383367	1	Spring Clip
13	430053	1	Solution Control Cable
14	711228	6	Bolt-HH 5/16-18 x 3/4
15	711545	6	WSR-Helical 5/16
16	711575	6	WSR-Flat 5/16
17	200032	1	Console Back Cover Weldment
18	450054	1	Vacuum Recovery Hose
19	740711	1	Switch Dreefs
20	740811	2	Switch Boot
21	740800CE	1	Switch Momentary

CONSOLE ASSEMBLY

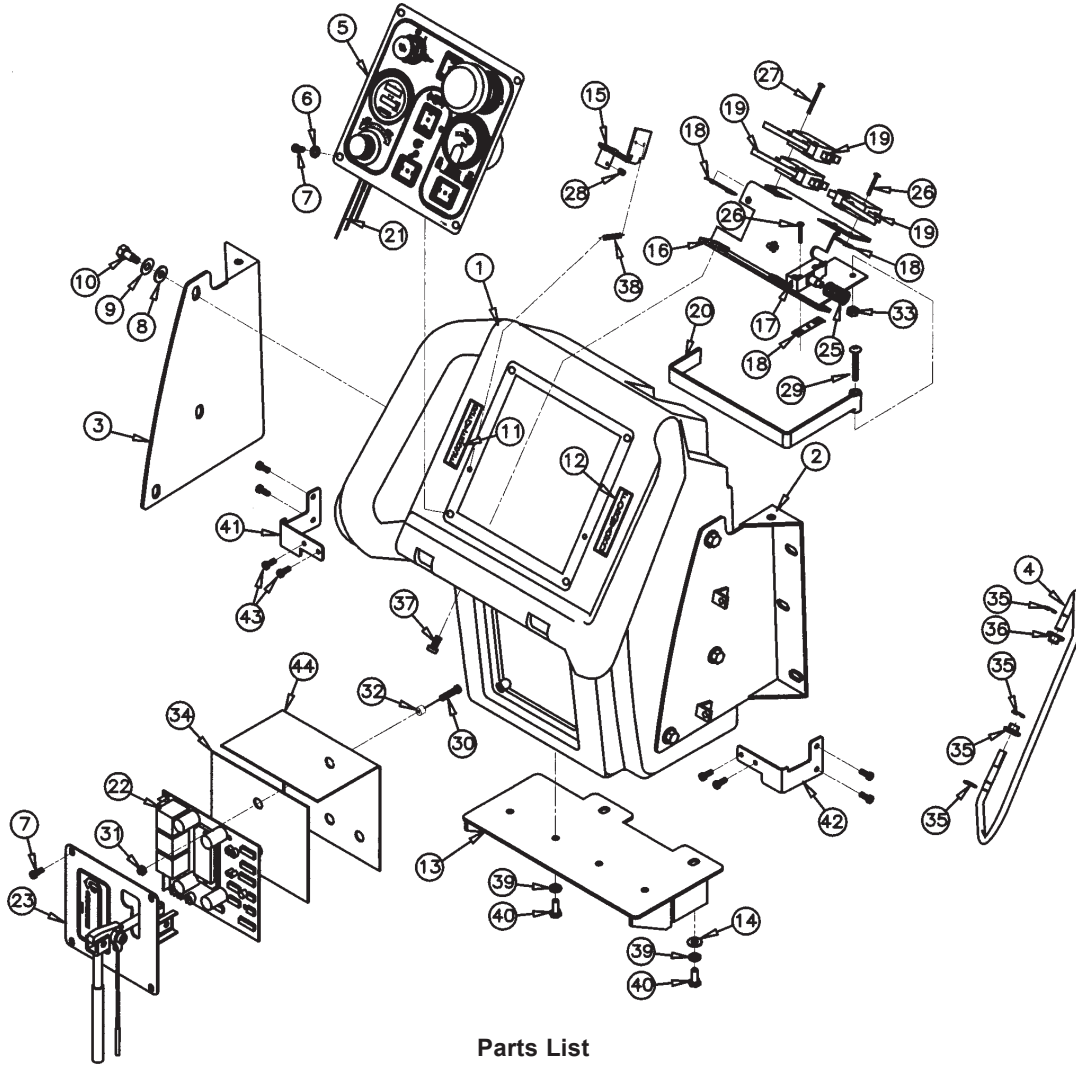

Parts List

Item	Part No.	Qty.	Description	Item	Part No.	Qty.	Description
1	200104MCH	1	Console Machined	23	200240	1	Squeegee Lift Assy.
2	200134	1	Console Bracket Right	24	200241	1	Squeegee Lift Cable
3	200135	1	Console Bracket Left	25	670093	1	Spring, Compression
4	200181CTD	2	Handle Wire, Coated	26	710207	4	SCR-MC 6-32 x .87 ST PL
5	200295	1	Dashboard Assy.	27	710312	2	SCR-MC 6-32 x 1.75 ST PL
6	712320	4	WSR-Nylon .22 x .45 x .04	28	711004	2	SCR-SK 1/4-20 x .25 SS
7	712540	8	SCR-MC #10-24 x .37 SS	29	712569	1	SCR-MC 1/4-20 x 1.50 SS
8	711575	6	WSR-Flat .31 x .75 x .06	30	710534	2	SCR-MC #8-32 x 1"
9	711545	6	WSR-Helical 5/16	31	711372	2	Nut, Nyloc #8-32
10	711228	6	Bolt-HH 5/16-18 x .75	32	200340	2	Spacer, S-C Board
11	715258	1	Decal, "Reverse"	33	829052	1	Nut, Hex 1/4-20
12	715257	1	Decal, "Forward"	34	805637	1	SCR Insulator
13	200151	1	Hinge Bracket Weldment	35	711721	6	Retaining Ring .312
14	711505	2	WSR-Flat 1/4	36	829052	4	Bushing Flanged, Nylon
15	200338	2	Cam Weldment	37	710180	2	SCR-MC 1/4-20 x 1"
16	200184	1	Switch Bracket Weldment	38	220324	2	Spring
17	742472	1	Switch, McGill NC	39	711544	6	WSR-Helical 1/4
18	711430	3	Nut-Tinnerman 6-32	40	711203	6	Bolt-HH 1/4-20 x .62
19	833329SA	3	Switch, Staggered Action	41	200039	1	Bail Stop (RH)
20	200190CTD	1	Lever, Switch, Coated	42	200040	1	Bail Stop (LH)
21	743240	1	Harness, 200 Console	43	711160	8	Screw Hi-Lo #10 x 5/8 PL
22	740944	1	Speed Control, 24V 1203A225	44	260210	1	Moisture Guard SCR 260TD

MOTOR LIFT ASSEMBLY

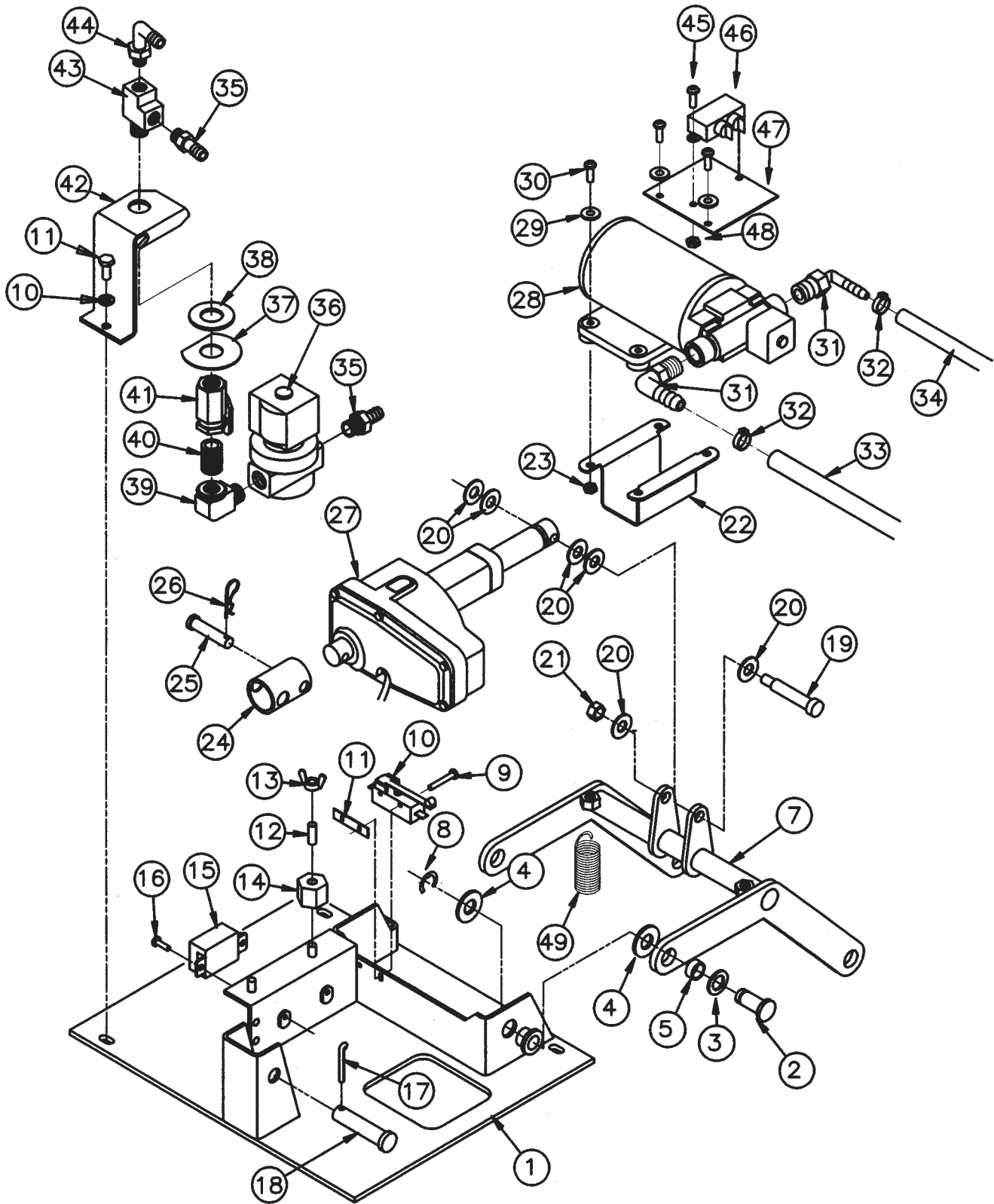

Parts List

Item	Part No.	Qty.	Description
1	200249	1	Base Plate Weldment-Deluxe
2	260036	2	Pin Retainer
3	712310	4	WSR-Flat .52 x .88 x .06
4	711527	6	WSR-Flat 5/8 x 1/12 x .12
5	762340	2	Oilite Bushing 1/2
6	260041	4	Oilite Flanged Bushing 1/2
7	200509	1	Lift Arm Weldment-Deluxe
8	711713	2	E-Ring 1/2
9	710207	2	SCR-MC 6-32 x .87
10	740128	1	Microswitch
11	711430	1	Tinnerman Clip
12	833638	2	Brass Stud
13	711368	2	Wing Nut
14	740132	2	Insulator Glastic
15	743032	1	Terminal Block
16	712822	2	SCR-THMS 10-24 x 1/2
17	711807	1	Cotter Hair Pin
18	711672	1	Clevis Pin 1/2
19	712126	1	Shoulder Bolt 5/16 x 1.75
20	711515	6	WSR-Flat .406 x .81 x .063
21	712683	1	Nut-Nyloc 5/16-18 SS
22	200174	1	Pump Mounting Bracket
23	712638	1	Nut-Nyloc 10-24 SS
24	200248	1	Pivot Tube
25	831965	1	Clevis Pin 3/8 x 1.63
26	711808	1	Cotter Pin
27	743503	1	Actuator
28	833299	1	Pump
29	711505	5	WSR-Flat 1/4
30	712532	5	SCR-MC 10-24 x 1 SS
31	833325	2	Elbow 3/8 Barb x 1/4NPT
32	450076	2	Crimp Clamp 185R
33	200282	1	Hose Pump Inlet
34	200281	1	Hose Pump Outlet
35	342430	2	Fitting 3/8 Barb x 3/8 MPT
36	743505	1	Water Solenoid 24V
37	829463	1	WSR-Flat SS
38	828975	1	WSR-Neoprene .75 x 1.5 x .09
39	830062	1	3/8 Street 90 Brass
40	383332	1	3/8 Closed Nipple
41	809413MCH	1	Solution Valve Machined
42	200259	1	Valve Bracket
43	210408	1	Fitting Brass Tee 3/8 NPT
44	450040	1	Elbow 3/8 Barb x 3/8 MPT
45	710329	2	SCR-MC 8-32 x .5
46	742391	1	RFI Fliter
47	200335	1	RFI Bracket
48	711372	2	Nut-Nyloc 8-32
49	760594	2	Spring, Extension

SCRUBHEAD ASSEMBLY

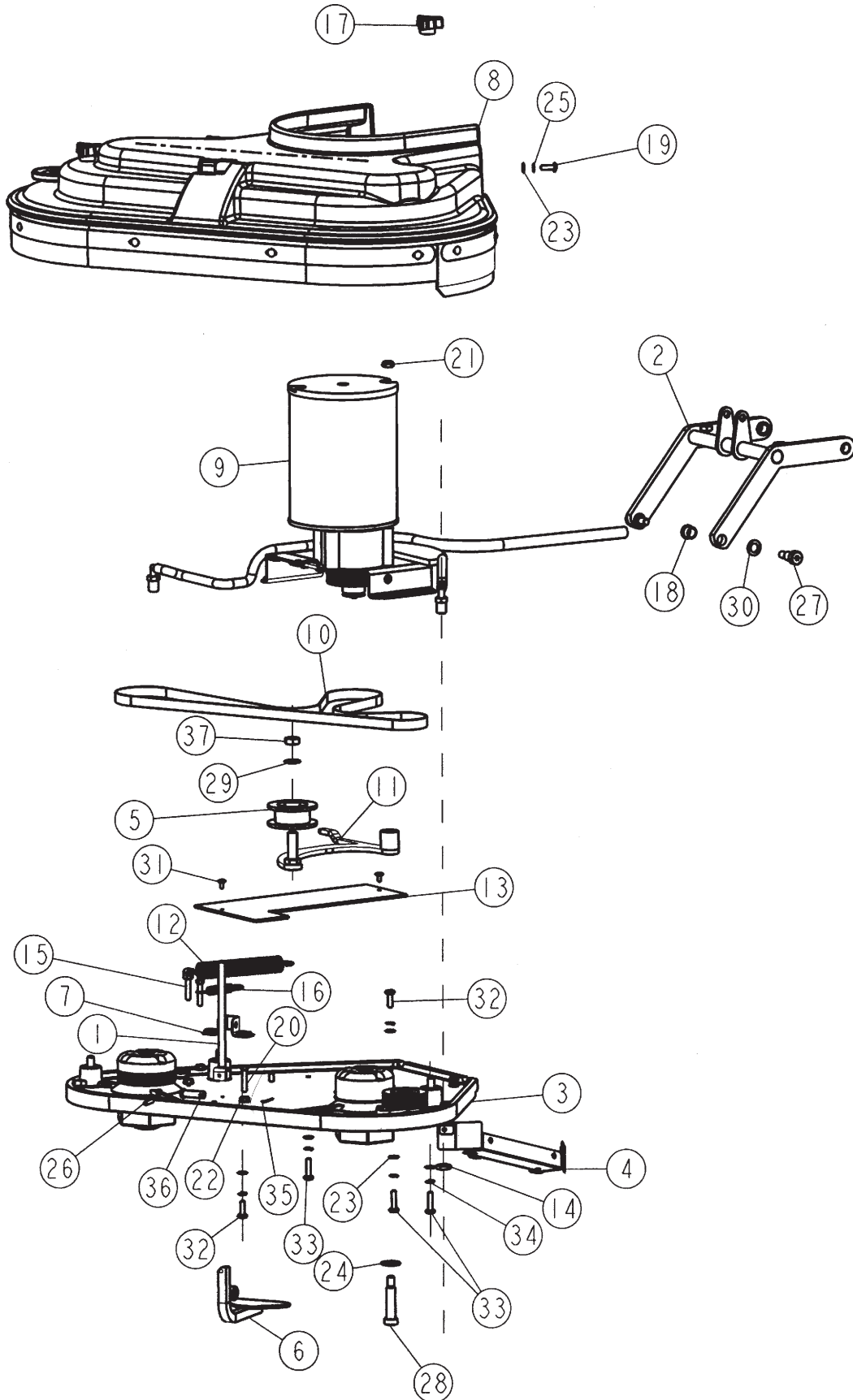

Parts List

Item	Part No.	Qty.	Description
1	200038	1	Handle Shaft Weldment
2	200509	1	240X Lift Weldment
3	200525	1	Scrubdeck Casting Assy
4	200530	1	Spring Mount
5	200531	1	Belt Idler w/Bushing
6	200545	1	Brush Release Lever Weldment
7	200548	1	Bracket, Brush Release
8	200570	1	Cover Assy - 240X Scrubdeck
9	200574	1	Brush Motor Assy, 240X
10	200579	1	Belt, Brush Drive
11	200586	1	Idler Arm Weldment
12	200588	1	Extension Spring .875 OD x 6.00
13	200589	1	Idler Arm Liner
14	260183	2	Nut 1/4 Npt Nylon, Half
15	260292	1	Spring Catch
16	430051	1	Return Spring 3.00"
17	430074	3	Adjusting Nut 17B/E
18	670117	4	Oilite Flanged Bushing
19	710180	2	SCR-MC 1/4-20 x .75 TR HD
20	711210	2	BLT-HH 1/4-20 x 1.25 STPL
21	711375	1	Nut-Nyloc 3/8-16 x 1/2 Nut
22	711425	3	Nut, Hex 1/4-20 Wiznut
23	711504	10	WSR-Flat 1/4 ID SS
24	711509	1	WSR-Flat 1/2 (.54x 1.082 x .087)
25	711564	2	WSR-External Lock 1/4
26	711642	1	Roll Pin .187 x 1.00
27	712122	2	BOLT-SHLDR 1/2 x 5/8
28	712132	1	BOLT-SHLDR 1/2 x 1-3/4"
29	712301	1	WSR-Flat .87 x .38 x .06
30	712310	2	WSR-Flat .52 x .87 x .06 PL
31	712540	2	SCR-MC 10-24 SS TH
32	712562	4	BLT-HH 1/4-20 x 3/4 SS
33	712564	4	BLT-HH 1/4-20 x 1.00 SS
34	712758	8	WSR-Helical 1/4 SS
35	809311	1	Pin Cotter 7/64 Dia x 1
36	833833	1	Clevis Pin
37	364-816	1	1/2-13 Nyloc Half Nut

CASTING ASSEMBLY

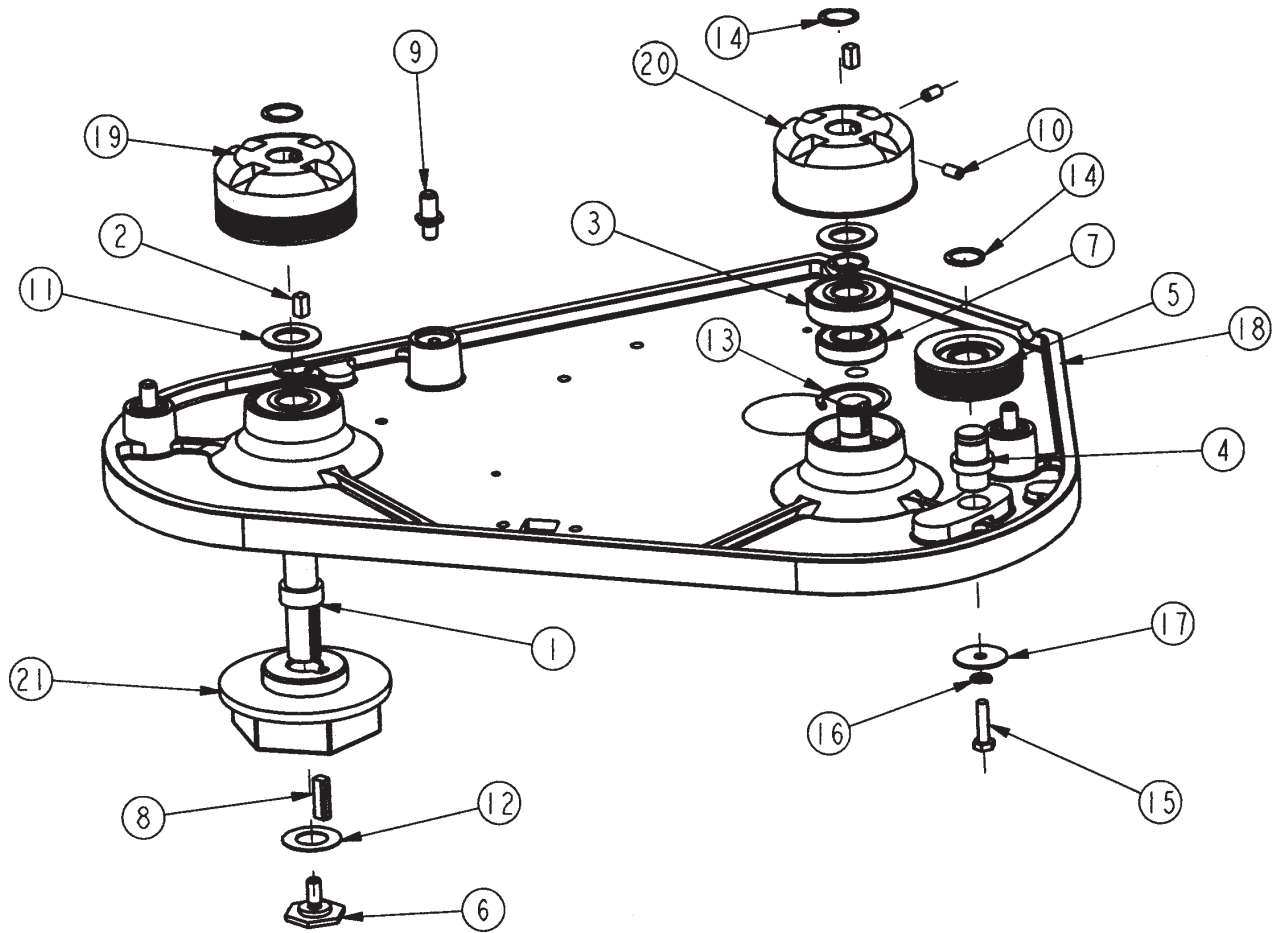

Parts List

Item	Part No.	Qty.	Description
1	200514	2	Shaft Driven
2	200527	2	Key 1/4 x 1/4 x 1/2
3	200532	2	Bearing
4	200566	1	Idler Pin
5	200578	1	Pulley Bearing Assy
6	210066	2	Drive Hub Retainer Bolt
7	250016	2	Bearing
8	320268	2	Key 1/4 x 5/16 x 1.00
9	430075	3	Threaded Insert
10	711016	4	SCR-SK 1/4-20 x .50 - Cup Pt Set SCR
11	711512	2	WSR-Flat .75 x 1.37 x .08
12	711517	2	WSR-Flat .75 x 1.375 x .09 SS
13	711702	2	Retaining Ring, Int. 1.62
14	711715	5	Retaining Ring, Axt 1.00
15	712564	1	Bolt-HH 1/4-20 x 1.00 SS
16	712758	1	WSR-Helical 1/4 SS
17	712761	1	WSR-Flat .28 x 1.25 x .059SS
18	200501MCH	1	240X Scrubdeck Casting
19	200557MCH	1	Drive Pulley
20	200558MCH	1	Drive Pulley
21	430035-1	2	Drive Hub

DRIVE MOTOR ASSEMBLY

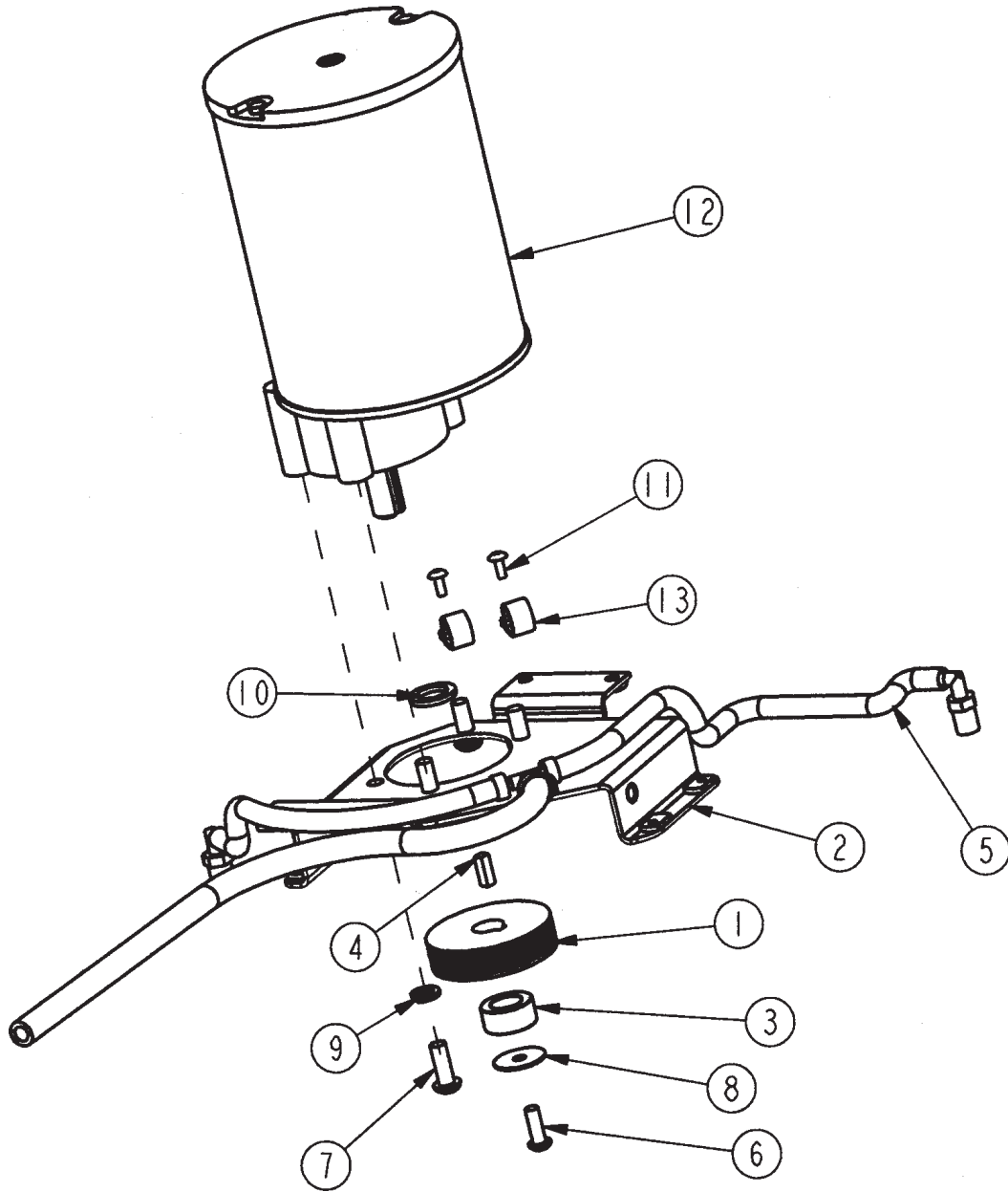

Parts List

Item	Part No.	Qty.	Description
1	200517	1	Drive Pulley Poly V
2	200518	1	240X Motor Plat Weldment
3	200521	1	240X Motor Spacer
4	200528	1	Key 1/4 x 1/4 x 3/4
5	200580	1	Hose Assy, 240X Scrubdeck
6	710975	1	SCR-SC 5/16-18 x .87 ST PL
7	710986	4	SCR-SC 3/8-16 x .87 ST PL
8	711516	1	WSR-Flat .31 x 1.25 x .05
9	711546	4	WSR-Helical 3/8
10	712318	2	WSR-Flat .75 x 1.12 x .12 PL
11	712822	2	SCR-MC 10-24 x .50 TH SS
12	740209	1	Motor 24V 1HP
13	827998	2	Clamp

DASHBOARD

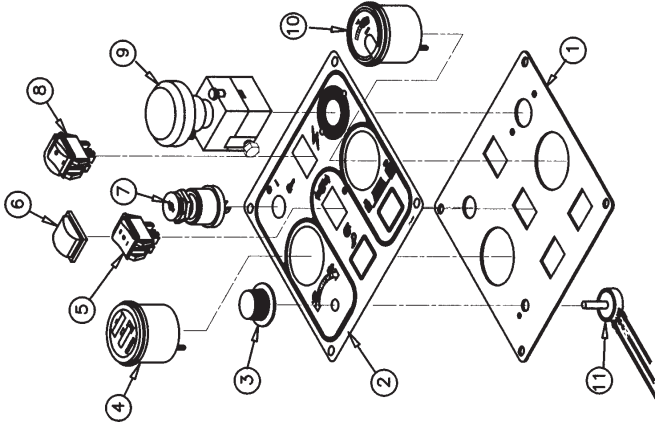

Parts List for 200295

Item	Part No.	Qty.	Description
1	200179	1	Dashboard Plate
2	715280	1	Decal 200 Dashboard
3	809874	1	Knob
4	743501	1	Meter, Hour Battery 24V
5	742102	1	Switch, 23670C4D
6	740811	2	Switch Boot
7	741005	1	Keyswitch On-Off
8	740711	1	Switch Dreefs
9	742202	1	Disconnect Switch 125A
10	743049	1	Gauge, Brush Pressure
11	743240	1	Harness 200X Console

BACK PANEL

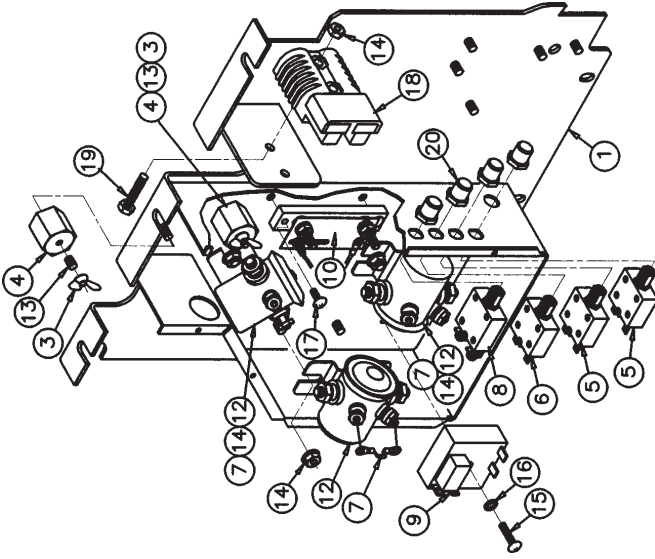

Parts List for 200175-1

Item	Part No.	Qty.	Description
1	200124	1	Backpanel Weldment
2	711368	2	Wing Nut, 1/4-20
3	740132	2	Insulator (Glastic)
4	740238	2	Circuit Breaker 18
5	740247	1	Circuit Breaker 30
6	742000	3	Diode Assembly
7	740549	1	Circuit Breaker 50
8	741037	1	5 Sec. True Off Delay Timer
9	740134-1	1	Shunt, Uncalibrated
10	743250	1	Wire Harness, Lower Assy.
11	788147	3	Solenoid 24VDC
12	833638	2	Brass Stud
13	711425	8	Whiz-Nut 1/4-20
14	712823	1	SCR-THMS 10-24 x 1"
15	712920	1	WSR-Nylon .22 x .42 x .04
16	712536	2	SCR 10-24 x .62
17	740159	1	CB175 Red Housing Only
18	711210	2	SCR-HH 1/4-20 x 1 1/4
19	742748	4	Boot, Circuit Breaker

SQUEEGEE LIFT

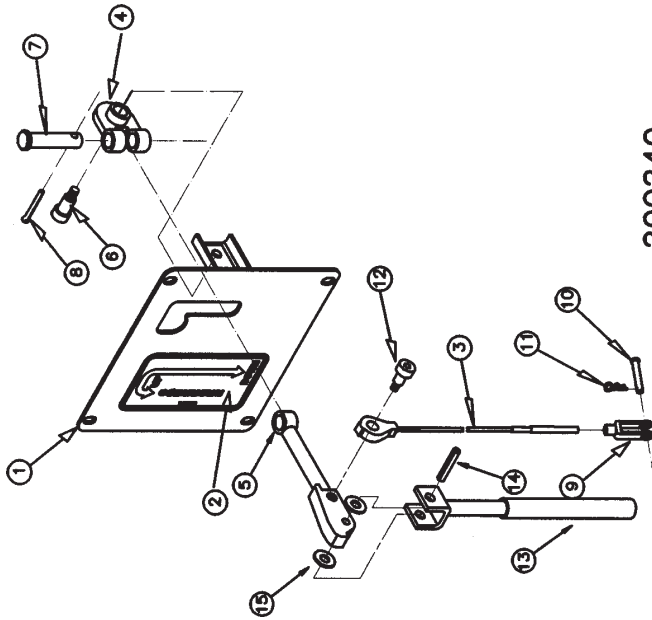

200240

Parts List for 200240

Item	Part No.	Qty.	Description
1	200239	1	Panel Cover Weldment
2	715603	1	Decal Squegee Lift
3	200241	1	Squegee Lift Cable
4	200261	1	Inner Arm Weldment
5	200017	1	Arm Squegee, Lift Weldment
6	712070	1	Bolt, Shoulder 5/16 x .75
7	831965	1	Clevis Pin 3/8
8	809311	1	Cotter Pin 7/64 x 1"
9	881009	1	Yoke
10	881002	1	Clevis Pin 5/16
11	711808	1	Cotter Pin #13
12	712041	1	Bolt-Shoulder 5/16 x .44
13	200038	1	Handle Weldment
14	711642	1	3/16 X 1.00 Roll Pin
15	711504	2	WSR-Flat 1/4 SS

SQUEEGEE MECHANISM

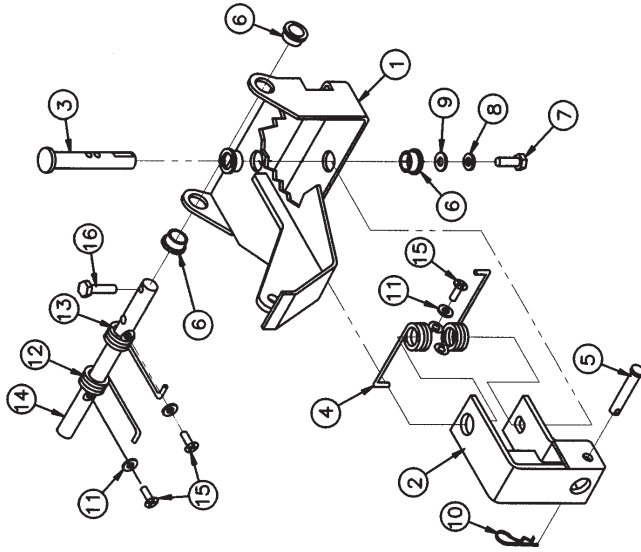

200153

Parts List for 200153

Item	Part No.	Qty.	Description
1	200144	1	Spring Housing Weldment
2	200300	1	Yoke Weldment
3	210375	1	Swivel Pin
4	210391	2	Return Spring SS
5	210415	1	Clevis Pin .31 x 1.7 11-097
6	260041	4	Oilite Flange Bushing
7	710180	1	SCR-MC 1/4-20 x .75 ST PL
8	711544	1	WSR-Helical 1/4
9	711519	1	WSR-Flat .25 x 1.01 x .06
10	711808	1	Cotter Pin - Hair #13
11	712320	2	WSR-Nylon .22 x .45 x .04
12	900080	1	Spring, Torsion RH
13	900081	1	Spring, Torsion LH
14	200159	1	Pin
15	712536	4	SCR-MC 10-24 x .62 SS
16	712564	1	BLT-HH 1/4-20 x 1.00 SS

COVER ASSEMBLY 200570

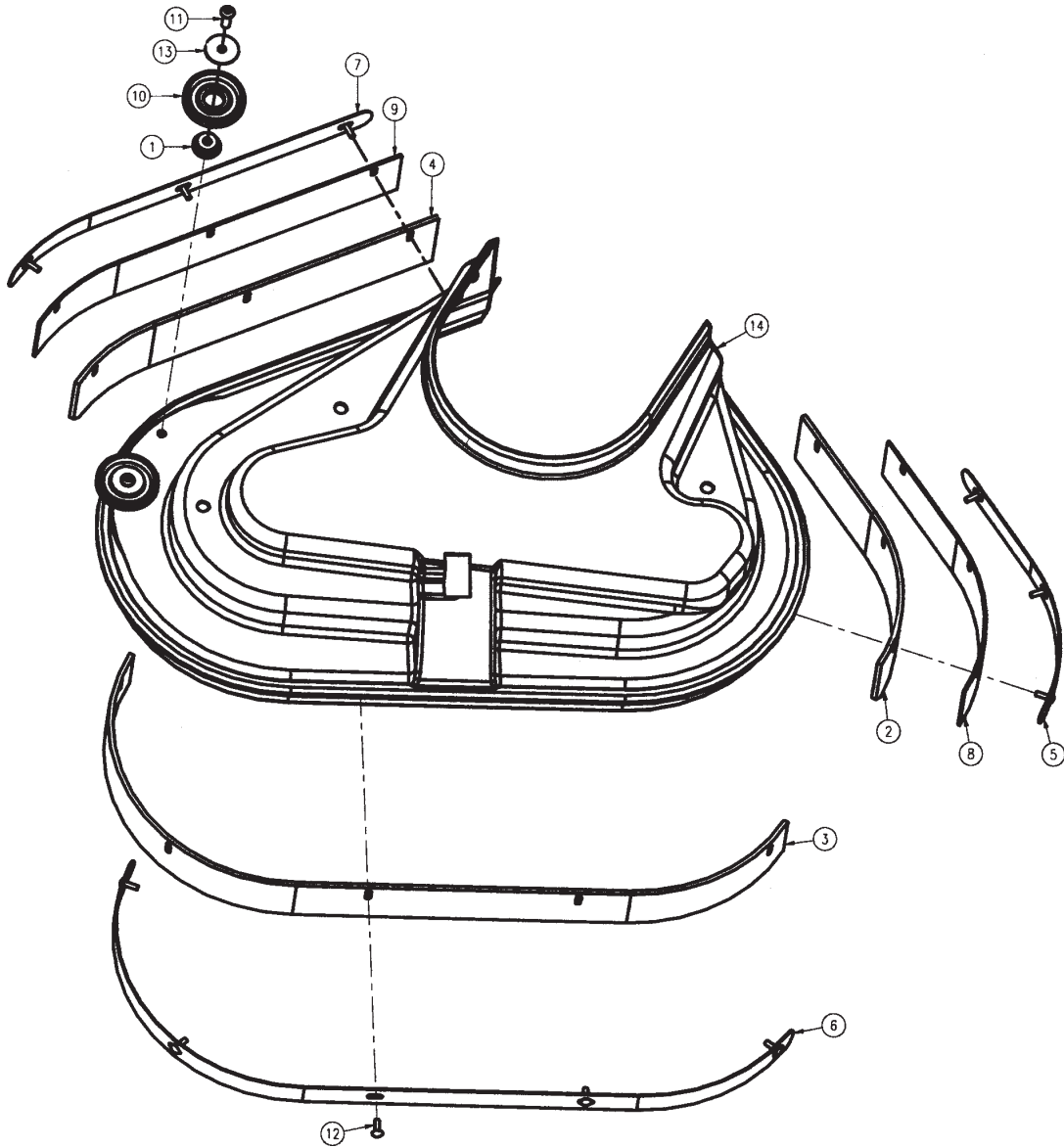

Parts List

Item	Part No.	Qty.	Description
1	200535	2	Roller Spacer
2	200551	1	Skirt, Left 240X
3	200552	1	Skirt, Center 240X
4	200553	1	Skirt, Right 240X
5	200554	1	Skirt Retainer, Left 240X
6	200555	1	Skirt Retainer, Center 240X
7	200556	1	Skirt Retainer, Right 240X
8	200571	1	Left Backer Plate, 240X
9	200573	1	Right Backer Plate, 240X
10	430085	2	Squeegee Bumper Wheel
11	710975	2	SCR-SC 5/16-18 x .87 ST PL
12	711160	11	#10 x 5/8 Hi-Lo
13	712759	2	WSR-Fit .31 x 1.37 x .06 SS
14	200522MCH	1	240X Scrubdeck Cover

SQUEEGEE ASSEMBLY - 200219

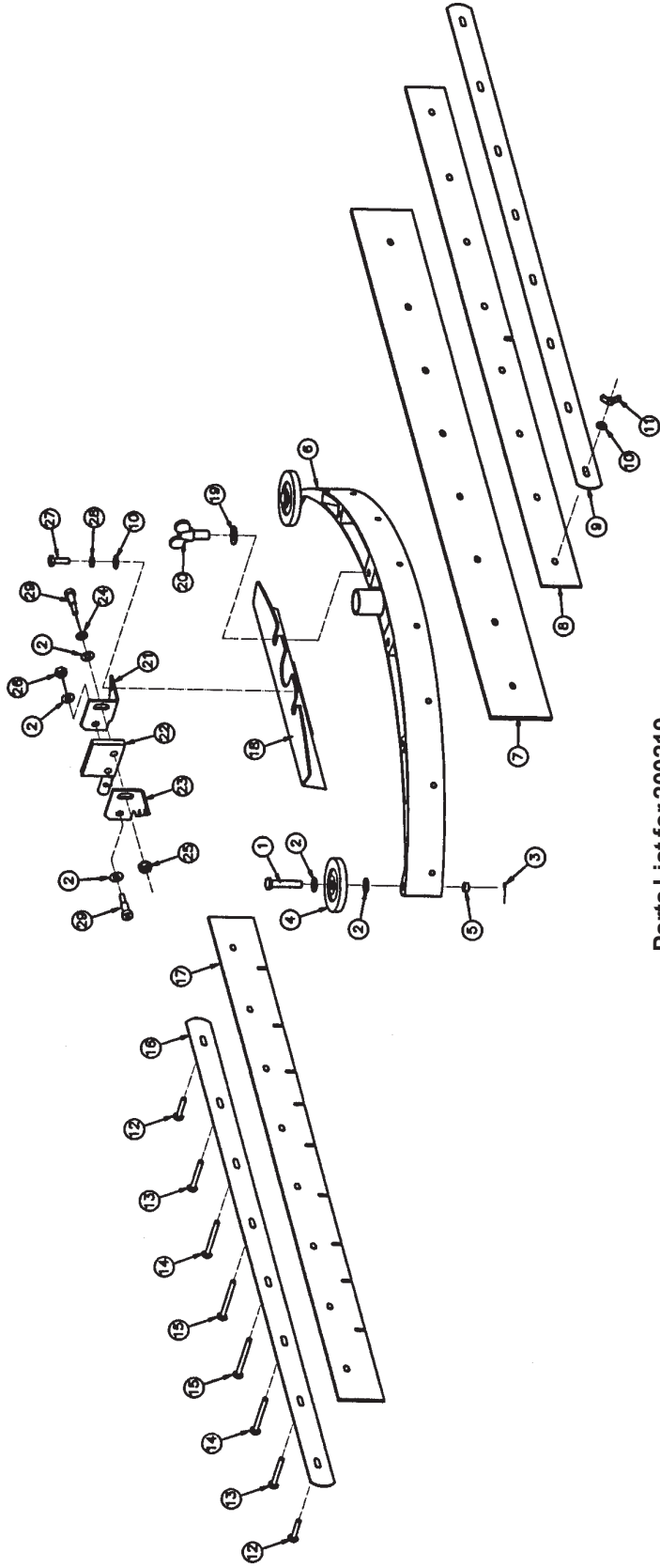

Parts List for 200219

Item	Part No.	Qty.	Description	Item	Part No.	Qty.	Description
1	711668	2	Clevis Pin 3/8 x 1	16	260273	1	Front Blade Strap
2	711507	7	WSR-Flat .37 x 1.12 x .06	17	260322	1	Squeegee Blade 260 Quarry
3	711808	2	Cotter Pin - Hair #13	18	320191	1	Squeegee Mounting Bracket
4	210153	2	Roller Wheel	19	711578	2	WSR-Flat 1/2 Brass
5	762281	2	Bushing .37 x .500 x .25	20	220249	2	Wing Bolt 1/2-13 x .75
6	200222	1	Squeegee Casting, 200	21	320156	1	Mounting Bracket - Right
7	260203	1	Rear Squeegee Blade	22	200169	1	Pitch Control Weldment
8	260264	1	Reinforcement Blade	23	320157	1	Mounting Bracket - Left
9	260272	1	Rear Blade Strap	24	712301	1	WSR-Flat .37 x .87 x .07
10	711504	12	WSR-Flat .25 x .56 SS	25	711379	1	Nut- Flanged Wizz 5/16-18
11	712668	8	Wing Nut 1/4-20 SS	26	711374	1	Nut-Nyloc 5/16-18
12	712571	2	Bolt-SS Carr 1/4-20 x 1.50	27	712562	4	Bolt-HH 1/4-20 x .75 SS
13	712572	2	Bolt-SS Carr 1/4-20 x 2.00	28	712758	4	WSR-Helical 1/4 SS
14	712573	2	Bolt-SS Carr 1/4-20 x 2.50	29	712081	2	Bolt-Shoulder 3/8 x .75
15	712574	2	Bolt-SS Carr 1/4-20 x 3.00				

240X WIRING DIAGRAM - MC240024CE

CONNECTORS IN CONSOLE ASSY

C1
REAR VIEW OF CONNECTOR
740319

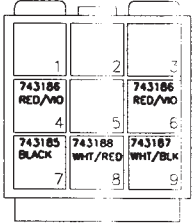

C2
REAR VIEW OF CONNECTOR
740320

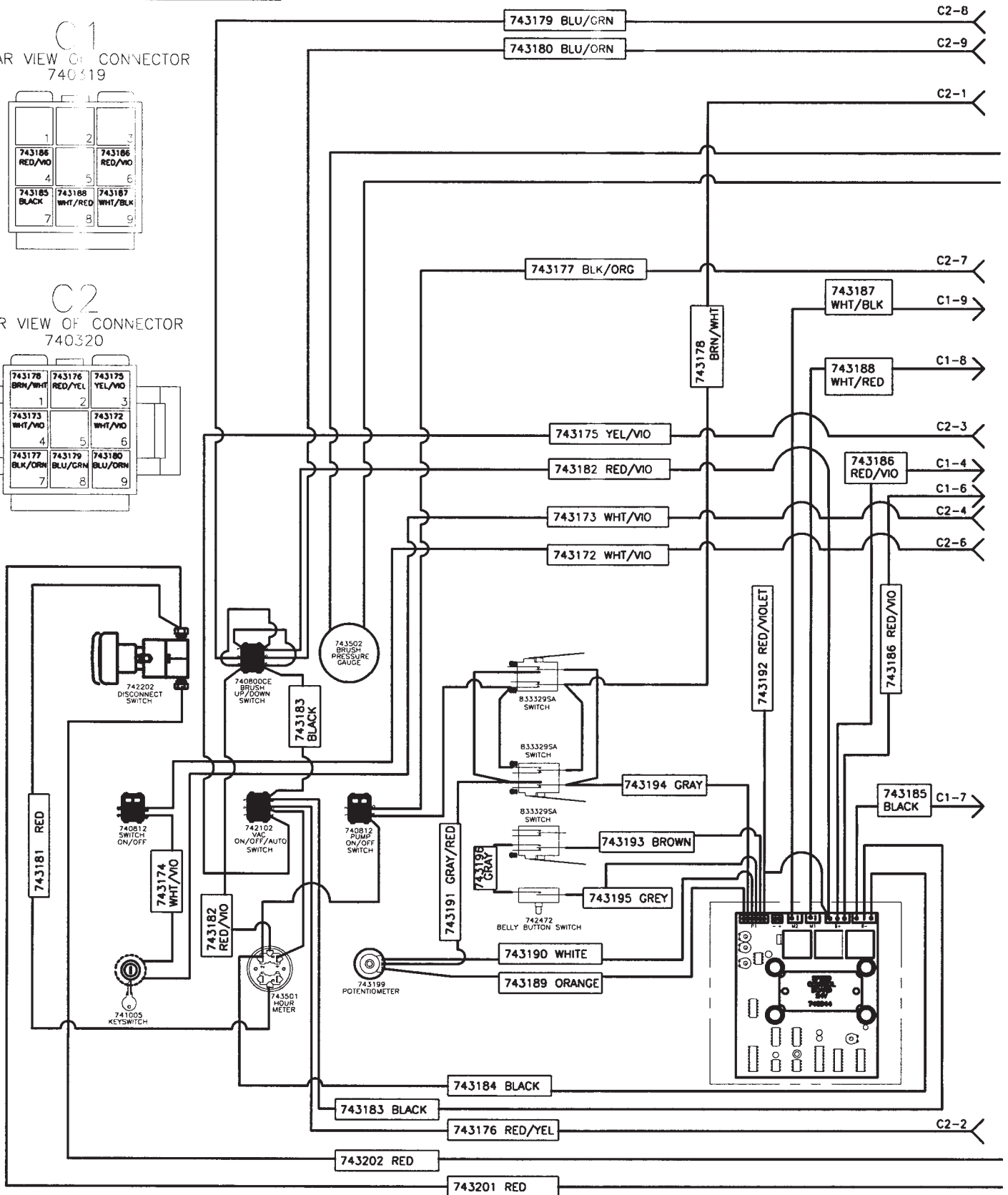
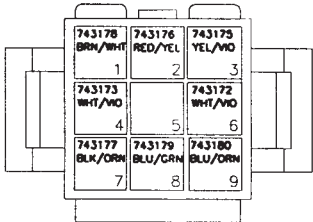

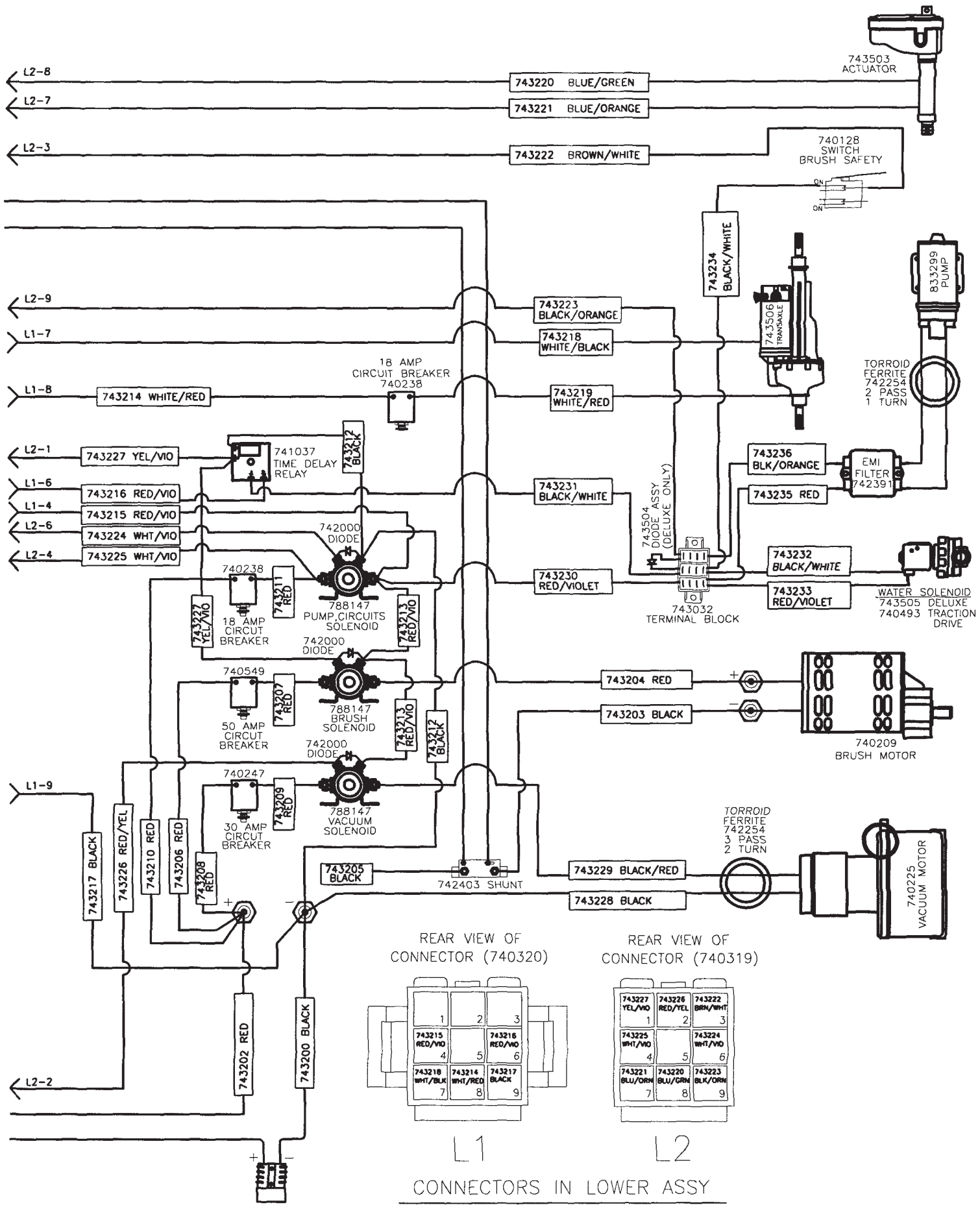

REAR VIEW OF CONNECTOR (740320)

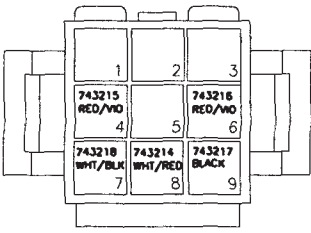

L1

REAR VIEW OF CONNECTOR (740319)

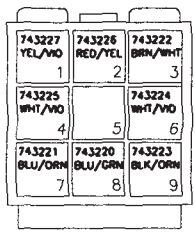

L2

CONNECTORS IN LOWER ASSY

LIMITED WARRANTY

Minuteman International, Inc. warrants to the original purchaser/user that this product is free from defects in workmanship and materials under normal use and service for a period of three years from date of purchase. In addition, Minuteman International, Inc. will, at its option, honor labor warranty claims for the first 12 months from date of sale, provided such claims are submitted through and approved by factory authorized repair stations. Minuteman International, Inc. will, at its option, repair or replace without charge, except for transportation costs, parts that fail under normal use and service when operated and maintained in accordance with the applicable operation and instruction manuals.

This warranty does not apply to normal wear, or to items whose life is dependent on their use and care, such as belts, cords, switches, hoses, rubber parts, electrical motor components or adjustments. Parts not manufactured by Minuteman International, Inc. such as engines, batteries, battery chargers, hydraulic pumps, and tires are covered by and subject to the warranties and/or guarantees of their manufacturers. Please contact Minuteman International, Inc. for procedures in warranty claims against these manufacturers.

Special warning to purchaser — Use of replacement filters and/or prefilters not manufactured by Minuteman International, Inc. or its designated licensees, will void all warranties expressed or implied.

A potential health hazard exists without exact original equipment replacement.

All warranted items become the sole property of Minuteman International, Inc. or its original manufacturer, whichever the case may be.

Minuteman International, Inc. disclaims any implied warranty, including the warranty of merchantability and the warranty of fitness for a particular purpose. Minuteman International, Inc. assumes no responsibility for any special, incidental or consequential damages.

This limited warranty is applicable only in the U.S.A. and Canada, and is extended only to the original user/purchaser of this product. Customers outside the U.S.A. and Canada should contact their local distributor for export warranty policies. Minuteman International, Inc. is not responsible for costs or repairs performed by persons other than those specifically authorized by Minuteman International, Inc. This warranty does not apply to damage from transportation, alterations by unauthorized persons, misuse or abuse of the equipment, use of non-compatible chemicals, or damage to property, or loss of income due to malfunctions of the product.

If a difficulty develops with this machine, you should contact the dealer from whom it was purchased.

This warranty gives you specific legal rights, and you may have other rights which vary from state to state. Some states do not allow the exclusion or limitation of special, incidental or consequential damages, or limitations on how long an implied warranty lasts, so the above exclusions and limitations may not apply to you.

Minuteman[®]

World Headquarters
Minuteman International, Inc.
111 South Rohlwing Road
Addison, Illinois 60101

(630) 627-6900
FAX (630) 627-1130

Minuteman Canada, Inc.
2210 Drew Road
Mississauga, Ontario
L5S 1B1

(905) 673-3222
FAX (905) 673-5161

983300
Printed in U.S.A.